

SONY[®]

3-751-783-23 (1)

Video Cassette Recorder

SLV-575UC

Operating Instructions

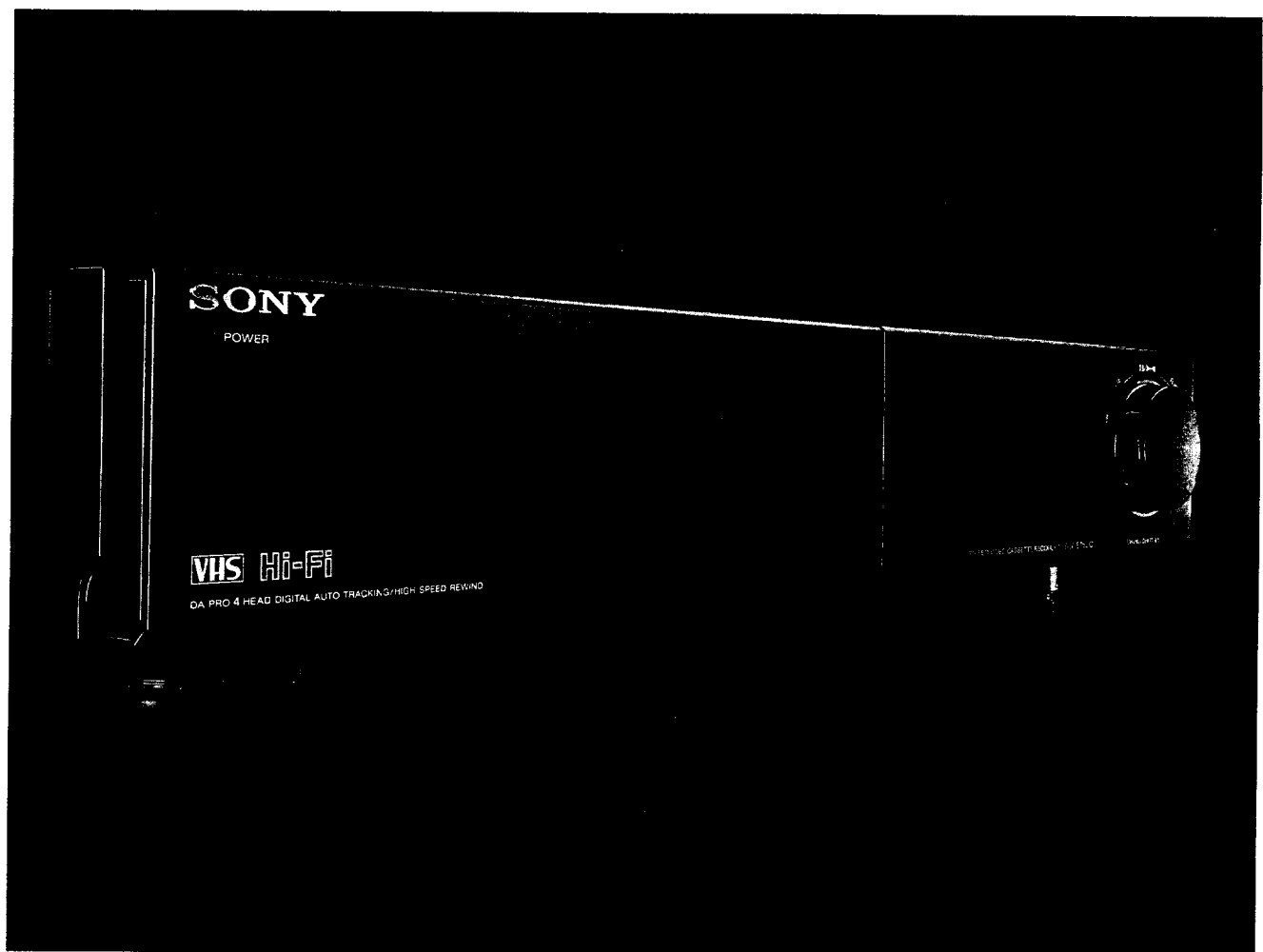

WARNING

To prevent fire or shock hazard, do not expose the unit to rain or moisture.

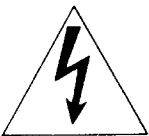
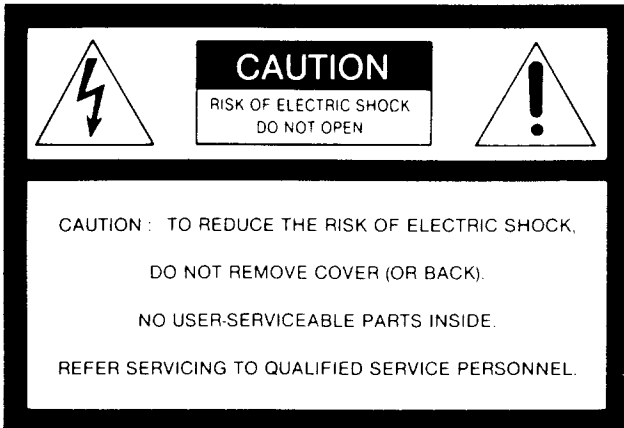

This symbol is intended to alert the user to the presence of uninsulated "dangerous voltage" within the product's enclosure that may be of sufficient magnitude to constitute a risk of electric shock to persons.



This symbol is intended to alert the user to the presence of important operating and maintenance (servicing) instructions in the literature accompanying the appliance.

For the customers in the U.S.A.

INFORMATION

This equipment generates and uses radio frequency energy and if not installed and used properly, that is, in strict accordance with the manufacturer's instructions, may cause interference to radio and television reception. It has been type tested and found to comply with the limits for a Class B computing device in accordance with the specifications in Subpart J of Part 15 of FCC Rules, which are designed to provide reasonable protection against such interference in a residential installation. However, there is no guarantee that interference will not occur in a particular installation. If this equipment does cause interference to radio or television reception, which can be determined by turning the equipment off and on, the user is encouraged to try to correct the interference by one or more of the following measures:

- Reorient the receiving antenna
- Relocate the equipment with respect to the receiver
- Move the equipment away from the receiver
- Plug the equipment into a different outlet so that equipment and receiver are on different branch circuits.

If necessary, the user should consult the dealer or an experienced radio/television technician for additional suggestions. The user may find the following booklet prepared by the Federal Communications Commission helpful:

"How to identify and Resolve Radio-TV Interference Problems". This booklet is available from the U.S. Government Printing Office, Washington, DC 20402, Stock No. 004-000-00345-4.

CAUTION

TO PREVENT ELECTRIC SHOCK, DO NOT USE THIS POLARIZED AC PLUG WITH AN EXTENSION CORD, RECEPTACLE OR OTHER OUTLET UNLESS THE BLADES CAN BE FULLY INSERTED TO PREVENT BLADE EXPOSURE.

Owner's Record

The model number is located at the front.
The serial number is located on the top of the panel.
Record the serial number in the space provided right.
Refer to them whenever you call upon your Sony dealer regarding this product.

Model No. SLV-575UC _____

Serial No. _____

Table of Contents

PRELIMINARIES	Precautions	4
	Introduction	5
	Identifying the Operational Parts	6
	Connections	12
	Adjusting a TV	19
PREPARATION	Menu System	20
	Mode Setting	22
	Date and Clock Setting	24
	Presetting Active Channels	26
	Handling Video Cassettes	29
OPERATION	PLAYBACK	
	Playing a Tape	30
	RECORDING	
	Recording TV Programs	37
	Use of the Tape Counter	42
	Timer Recording	44
	Quick Timer Recording	52
	Index Function	54
	Audio Recording	56
	EDITING	
Editing with Another VCR	58	
OTHER INFORMATION	Indications in the Display Window	61
	Troubleshooting	62
	Specifications	back cover

Precautions

On Safety

- Operate the unit only on 120V AC, 60Hz.
- Should anything fall into the cabinet, unplug the unit and have it checked by qualified personnel before operating it any further.
- One blade of the plug is wider than the other for the purpose of safety and will fit into the power outlet only one way. If you are unable to insert the plug fully into the outlet, contact your dealer.
- Unplug the unit from the wall outlet if it will not be used for an extended period of time. To disconnect the cord, pull it out by the plug. Never pull the cord itself.

On Installation

- Allow adequate air circulation to prevent internal heat build-up.
- Do not place the unit on surfaces (rugs, blankets, etc.) or near materials (curtains, draperies) that may block the ventilation slots.
- Do not install the unit near heat sources such as radiators or air ducts, or in a place subject to direct sunlight, excessive dust, mechanical vibration or shock.
- The unit is designed for operation in a horizontal position. Do not install it in an inclined position.
- Keep the unit and cassette tapes away from equipment with strong magnets, such as microwave ovens or large loudspeakers.
- Do not place any heavy object on the unit.

On Operation

- When the unit is not in use, turn the power off to conserve energy and to extend the life of the unit.
- Remove and store video cassettes after recording or playback.
- Store the cassettes in their cases and keep them in an upright position to prevent intrusion of dust and uneven winding.

On Cleaning

- Clean the cabinet, panel and controls with a dry, soft cloth, or a soft cloth slightly moistened with a mild detergent solution.
- Do not use any type of solvent, such as alcohol or benzene, which might damage the finish.

On Repacking

Do not throw away the carton and packing materials. They make an ideal container in which to transport the unit. When shipping the unit to another location, repack it as illustrated on the carton.

If you have any questions about this unit, contact your Sony dealer or qualified technician.

Before You Begin

- Check that the following accessories are in the carton with your VCR:
 - Remote Commander RMT-V575A (1)
 - Size AA (R6) batteries (2)
 - External antenna connector (1)
 - 75-ohm coaxial cable with F-type connectors (1)
 - Audio/video connecting cable (1)
- In the text of this manual, the buttons and switches are shown in capital letters.
Example:
Press **PLAY**.
- The buttons on the Commander and the VCR with the same mark have the same functions.
- Notes are enclosed in boxes.

Introduction

How to Use This Manual

This manual is arranged to help you quickly find the information you need for the operation of the SLV-575UC. This manual consists of the following 4 sections.

- 1 Preliminaries
- 2 Preparation
- 3 Operation
- 4 Other Information

First, look through the Table of Contents. If you are already familiar with VCR operation, read starting from the "Preparation" section. If you are new to VCR operation, start with "Identifying the Operational Parts" to familiarize yourself with this VCR. To have a quick overview of the operation of this VCR, refer to "Playing a Tape" (page 30), "Recording TV Programs" (page 37), and "Timer Recording" (page 44).

Overview of the SLV-575UC

Tape editing

Video/audio input jacks on front panel
Offer easy connection to another VCR.

Control S input
Allows this VCR to be remotely controlled by other equipment connected.

On-screen display

AUTO MENU
Displayed to set the VCR to the desired automatic tape operation.

AUTO REPEAT
Allows to play back the desired portion of the tape repeatedly.

Data screen
Displays tape counter, tape speed, remaining tape length, current date and time, etc.

Timer title
Just before a timer recording starts, the date, time and channel of the program are recorded.

Other convenient functions

AUTO TRACKING function
Automatically adjusts the tracking condition for optimum picture.

SWING SHUTTLE ring
Allows quick access to the desired scene.

Function memory
Enables starting of the desired tape operation with a press of the button.

High-quality picture/sound

High-quality picture
The SLV-575UC provides sharp, finely detailed pictures through High Quality picture technology.
HQ: The video cassette recorder (VCR) with this marking incorporates VHS high-quality picture technology and is compatible with any video cassette recorder bearing the **VHS** mark.

High quality sound
This VCR automatically performs hi-fi recordings.

Dynamic range: More than 90 dB
Wow and flutter: Less than 0.005%
Audio frequency response: 20 — 20,000 Hz
Reproduces clear sound

Identifying the Operational Parts

Front

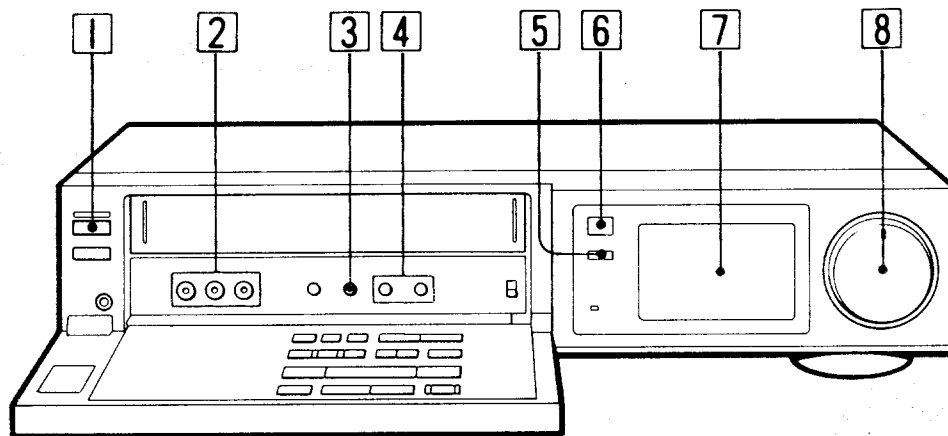
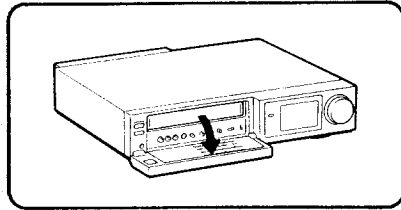

1 POWER switch and indicator

Press to turn on the power of the VCR. The indicator lights when power is supplied.

2 LINE IN 2 VIDEO/AUDIO jacks (phono type)

Connect to the video/audio output of other VCR or video camera.

3 SHARPNESS control

Adjust the sharpness of the playback picture if necessary. Normally set this control at the center indented position.

4 REC LEVEL controls

Adjust the audio recording level. Normally set these controls to the **5** position.

5 AUTO TRACKING indicator

Blinks while the VCR is searching for the best tracking position.
Lights when the best position is obtained.

6 Remote sensor

Point the supplied infrared Remote Commander RMT-V575A here.

7 Display window

See "Indications in the Display Window." (page 61)

8 SWING SHUTTLE ring

Turn to select the playback speed during playback or in recording pause mode.

Front

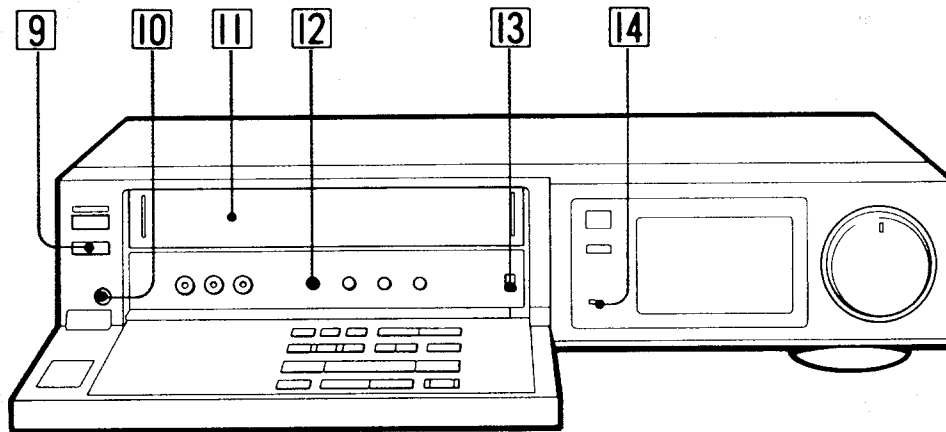

9 **EJECT button**

Press to eject the cassette.

10 **PHONES (headphones) jack (stereo mini type)**

Connect headphones.

11 **Cassette compartment**

Insert a cassette. When the cassette is inserted, the power is automatically turned on.

12 **PHONE LEVEL (headphone level) control**

Adjust the headphone level.

13 **COMMAND MODE selector**

To remotely control the VCR with the supplied Remote Commander, set this selector to the same position as that on the Commander.

Usually set both selectors to VTR 3.

14 **HIGH SPEED REWIND indicator**

Lights when you press **◀◀◀** HIGH SPEED REWIND.

Identifying the Operational Parts

Inside the Front Panel

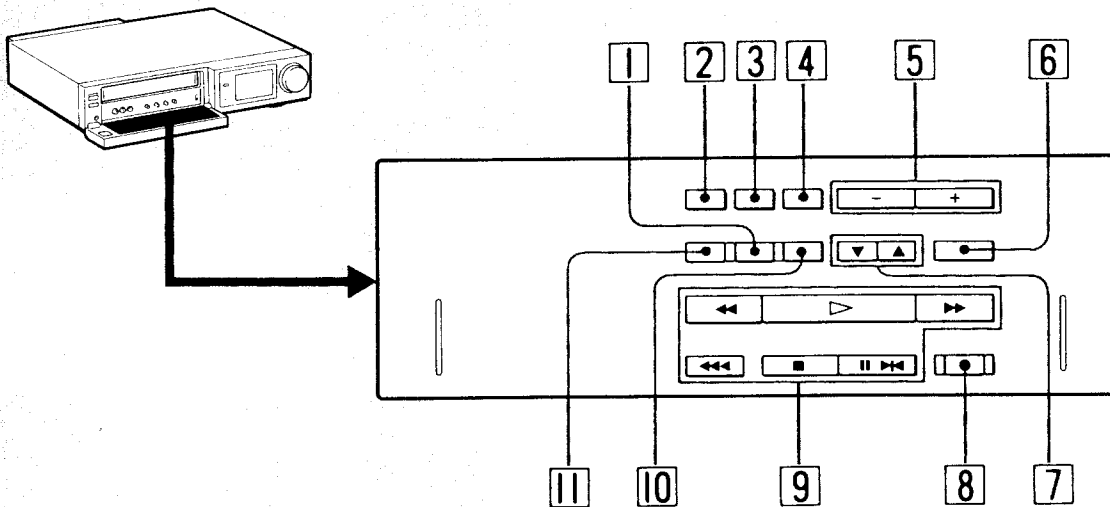

1 TIMER REC ON/OFF button

Press to set the VCR to timer recording standby mode.

When changing or canceling a timer recording, or operating the unit before a timer recording starts, press this button to get out of timer recording standby mode.

2 ANT TV/VTR button

Press so that the VTR indicator lights to watch a program selected on the VCR. To watch one TV program while recording another, press this button again to turn off the indicator.

3 INPUT SELECT button

Press so that the desired input mode indicator appears in the display window to select the program to be recorded. The indicator changes as follows.

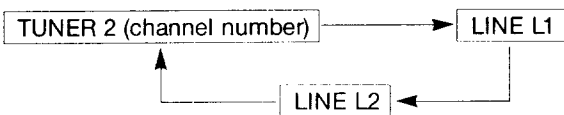

4 REC MODE button

Press to select the recording tape speed, SP or EP.

5 CHANNEL +/- buttons

Press to select the preset channels. Press + to advance and - to reverse.

6 TRACKING AUTO/MANUAL button

Press to reactivate the automatic tracking function after adjusting tracking manually.

7 TRACKING NORMAL/SLOW and STILL ADJUST buttons

Press either of the buttons to clear streaks that may appear on the screen during normal or slow speed playback or to reduce picture shaking in still mode.

8 ● REC button

Press to start recording.

9 Tape transport buttons

◀◀ REW (rewind), ▷ PLAY, ▶▶ FF (fast-forward), ■ STOP, || PAUSE/STILL, ◀◀◀ HIGH SPEED REWIND

10 QUICK TIMER button

Press to start quick timer recording and to set the recording duration.

11 EDIT ON/OFF button

Normally keep this button at OFF (i.e. the EDIT indicator is off in the display window). When using this VCR for editing, press this button to light the EDIT indicator.

Rear Panel

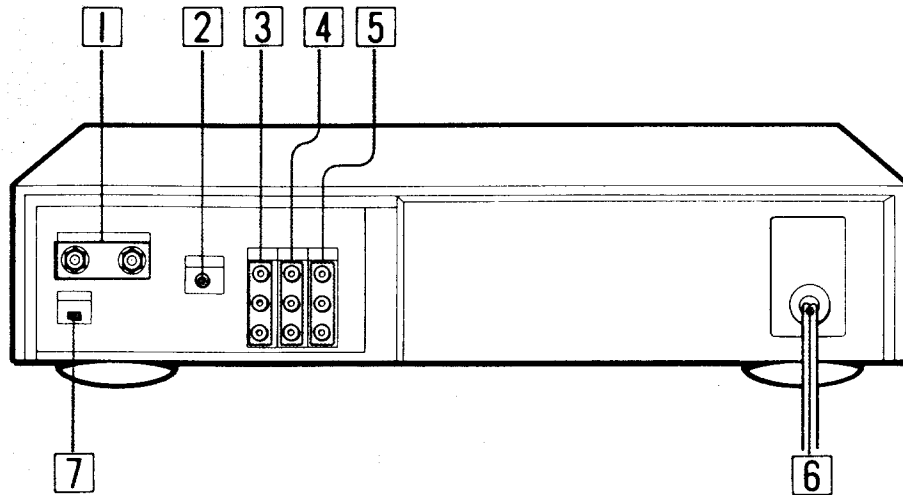

1 VHF/UHF IN and OUT connectors (F type)

2 CONTROL S IN jack (mini type)

Connect to the CONTROL S output jack of a Sony TV set or TV tuner to operate the VCR by remote control through them.

Also connect to the CONTROL S output jack of another Sony VCR for synchronized editing.

3 LINE IN 1 AUDIO and VIDEO jacks (phono type)

Connect to the LINE OUT AUDIO and VIDEO jacks of other video equipments.

4 LINE OUT AUDIO and VIDEO jacks (phono type)

Connect to the LINE IN AUDIO and VIDEO jacks of other video equipments.

If you connect the TV to these jacks, on-screen display does not appear.

5 MONITOR OUT AUDIO and VIDEO jacks (phono type)

Connect to the LINE IN jacks on a TV. The VCR displays on-screen display on the TV or monitor through this connection.

6 AC power cord

7 RF UNIT selector

Use to select the channel for VCR, 3CH or 4 CH, whichever is not active in your area.

Identifying the Operational Parts

Remote Commander

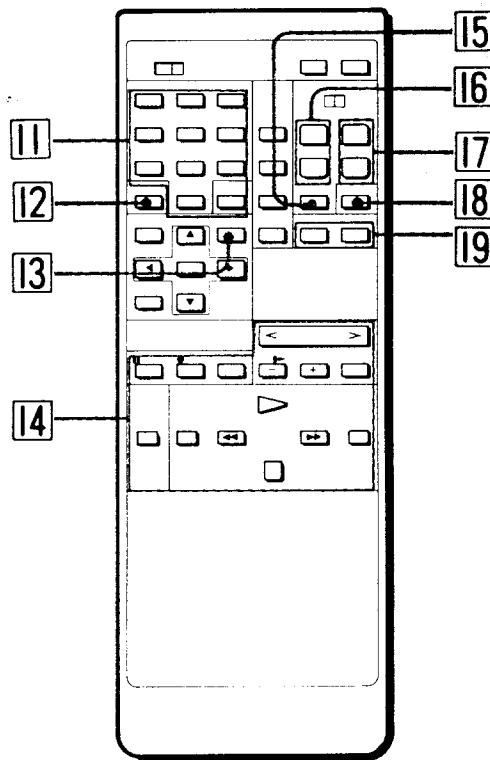
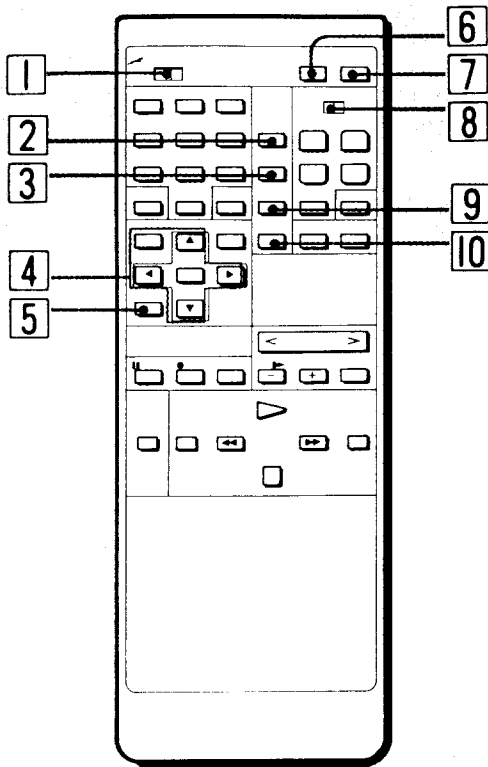

1 COMMAND MODE selector

To remotely control the VCR with the Commander, set this selector to the same position as that on the VCR. Usually set both selectors to VTR 3. Change the position as shown below to control other Sony VCRs.

VTR 1: For Sony Betamax VCRs

VTR 2: For Sony 8mm format VCRs

VTR 3: For Sony VHS format VCRs

2 INPUT SELECT button

Press to select the sources to be recorded. The selected input mode indicator appears in the display window.

3 REC MODE button

Press to select the recording tape speed, SP or EP.

4 Menu operation buttons

Press **MENU** to display or erase the main MENU. Press **◀/▶/▲/▼** to move the cursor or change the setting and press **EXECUTE** to store the setting.

5 FUNCTION MEMORY button

Press to execute one of the sequential tape operations in the FUNCTION MEMORY menu assigned to this button.

6 ANT TV/VTR (Antenna TV/VTR) button

Press to light the VTR indicator in the display window to watch the playback picture or the TV program selected on the VCR. When you want to watch a TV program while the VCR is in use, press this button again to turn off the VTR indicator. This button is effective when your TV is connected to the VCR via the VHF antenna terminal only.

7 POWER switch

8 TV/VTR selector

Set to TV when you use the supplied Commander to operate a TV and to VTR to operate a VCR.

9 DATA SCREEN button

Press to erase or display the on-screen display.

10 COUNTER RESET button

Press to reset the counter number to 0H00M00S.

11 Channel number and ENTER buttons

Press the appropriate button(s) and **ENTER** to select the channel directly.

For example, to select channel 10, press **1, 0** and **ENTER** or to select channel 4, press **4** and **ENTER**.

- [12] TIMER CLEAR button**
Press to clear the memory of the timer settings.
- [13] TIMER REC ON/OFF button**
Press to enter timer recording standby mode.
- [14] Tape transport buttons**
- || PAUSE
 - REC (Press two buttons simultaneously)
 - SLOW (+ : for faster speed, - : for slower speed)
 - < , > DIRECTION (Press to decide the direction of
 - ▶ PLAY, ×2 and SLOW. In playback still mode, frame-by-frame picture is available with this button.)
 - ×2 (double speed)
 - ⏮/⏭ SEARCH (reverse/forward)
 - ▶ PLAY
 - ◀◀ REW (rewind)
 - ▶▶ FF (fast-forward)
 - STOP
 - ◀◀◀ HIGH SPEED REWIND
- [15] AUDIO MONITOR button**
Press to select the monitor sound.
- [16] VOL (volume) + / - buttons**
Press to adjust the volume of the TV.
- [17] CHANNEL + / - buttons**
- [18] INDEX button**
Press to enter the index function mode.
- [19] INDEX MARK/ERASE buttons**
Press to mark or erase an index signal on a tape during recording or playback.

Battery insertion

- 1** Open the lid.

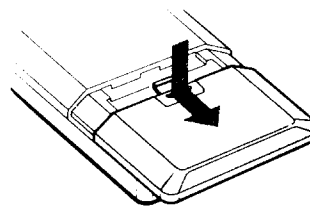

- 2** Insert two size AA (IEC designation on R6) batteries with the polarity lined up correctly.

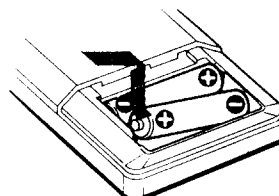

- 3** Close the lid.

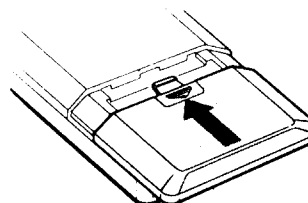

Notes on batteries

- With normal operation, the batteries last for approximately 6 months.
- If the Commander is not to be used for a long period of time, remove the batteries to avoid possible damage from battery leakage.

Connections

In order to watch the playback picture on the TV screen and receive TV programs on this VCR, the VCR and the TV must be connected properly.

The connections vary depending upon the type of TV and antenna that you have.

We will show you here some typical ways you can make these connections with the supplied accessories.

Before operating the VCR, read through this section and make the correct connections.

Before You Begin

- Turn off the power of the VCR and the TV.
- Do not connect the AC power cords until you complete all of the connections.
- **If your TV does not match the three examples below** Consult your nearest Sony dealer or qualified technician.

First Check Your TV

Basic connections

Check the antenna terminals on your TV

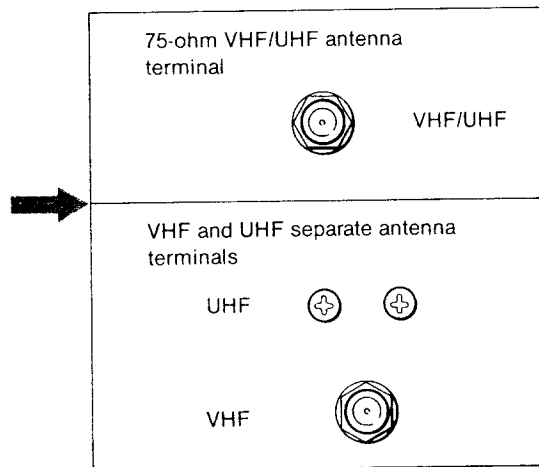

Read through "Connecting Examples 1 to 5."

Additional connections

If your TV has video and audio input jacks

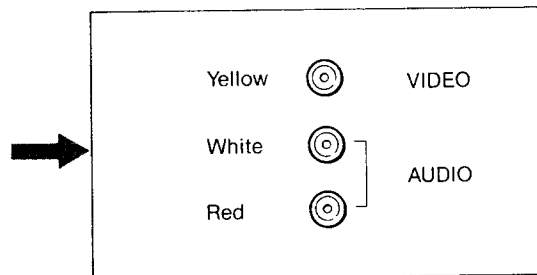

You can enjoy better picture quality. Read through "Connecting Example 6."

If you have an stereo audio system



You can enjoy better sound quality by connecting the VCR to the audio system. Read through "Connecting Example 7."

Caution

Connections between the recorder VHF/UHF OUT connector and the antenna terminals of a TV receiver should be made only as shown in the instructions. Failure to do so may result in operation that violates the regulations of the Federal Communications

Commission regarding the use and operation of rf devices. Never connect the output of the recorder to an antenna or make simultaneous (parallel) antenna and recorder connections at the antenna terminals of your receiver.

**Connecting Example 1
To Connect a Combination VHF/UHF Antenna**

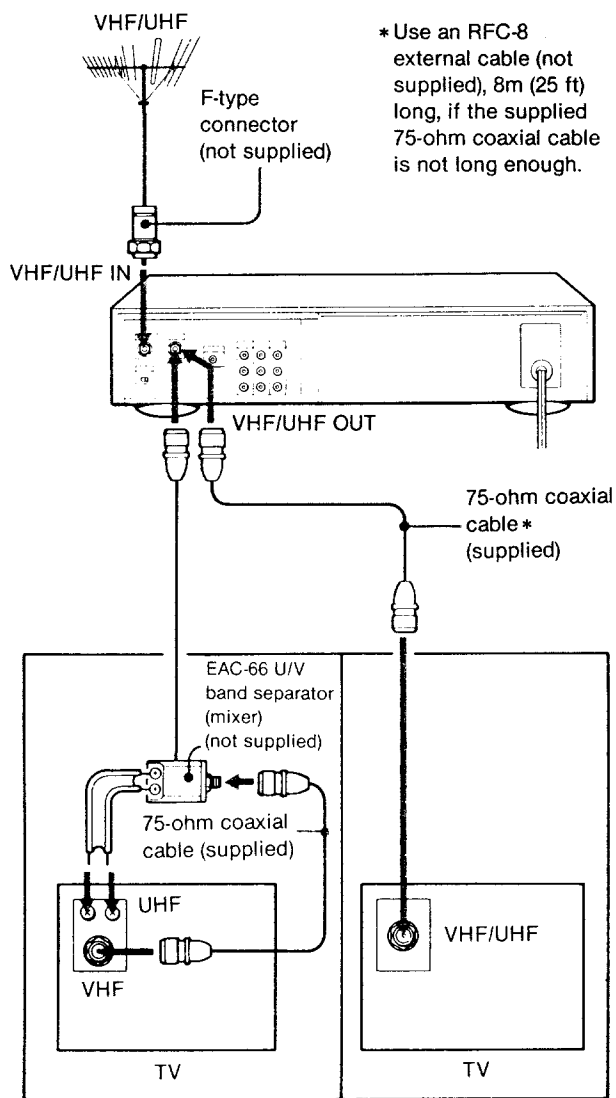

1 Disconnect the TV antenna cable from the TV and connect it to the VCR.

2 Connect the VCR and the TV.

If your TV has a single terminal for the VHF/UHF antenna

Connect directly using the supplied 75-ohm coaxial cable.

If your TV has separate VHF/UHF antenna terminals

Use a U/V band separator.

How to attach the U/V band separator and the F-type connector

See page 17.

**Connecting Example 2
To Connect a VHF Antenna Only**

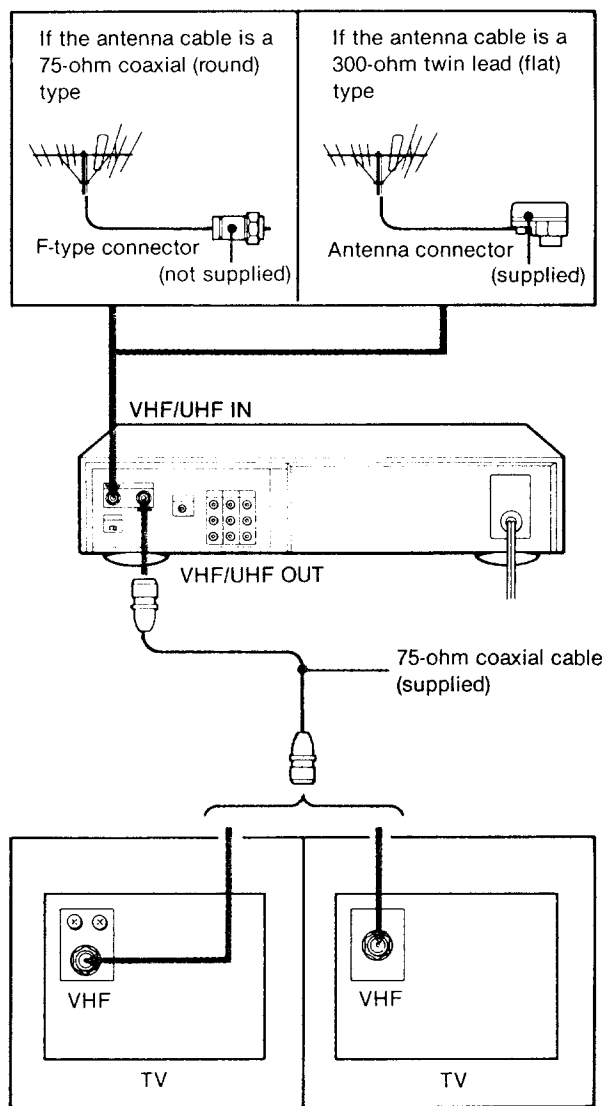

1 Disconnect the TV antenna cable from the TV and connect it to the VCR.

If the antenna cable is a 75-ohm coaxial (round) type
Use an F-type connector (not supplied).

If the antenna cable is a 300-ohm twin lead (flat) type
Use the antenna connector (supplied).

2 Connect VHF/UHF OUT on the VCR and the VHF antenna terminal on the TV with the 75-ohm coaxial cable (supplied).

How to attach the antenna connector and an F-type connector

See page 17.

Connecting Example 3 To Connect a UHF Antenna Only

A The VHF/UHF antenna terminal on the TV is combined

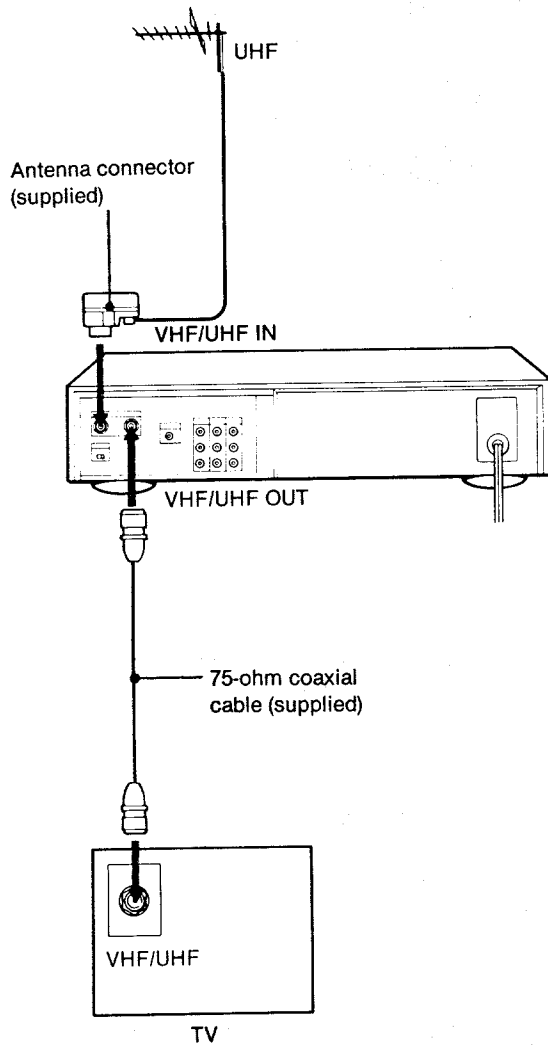

- 1 Attach the supplied antenna connector to the cable.
- 2 Attach the antenna connector to VHF/UHF IN on the VCR.
- 3 Connect VHF/UHF OUT on the VCR and the VHF/UHF antenna terminal on the TV.

B The VHF/UHF antenna terminals on the TV are separated

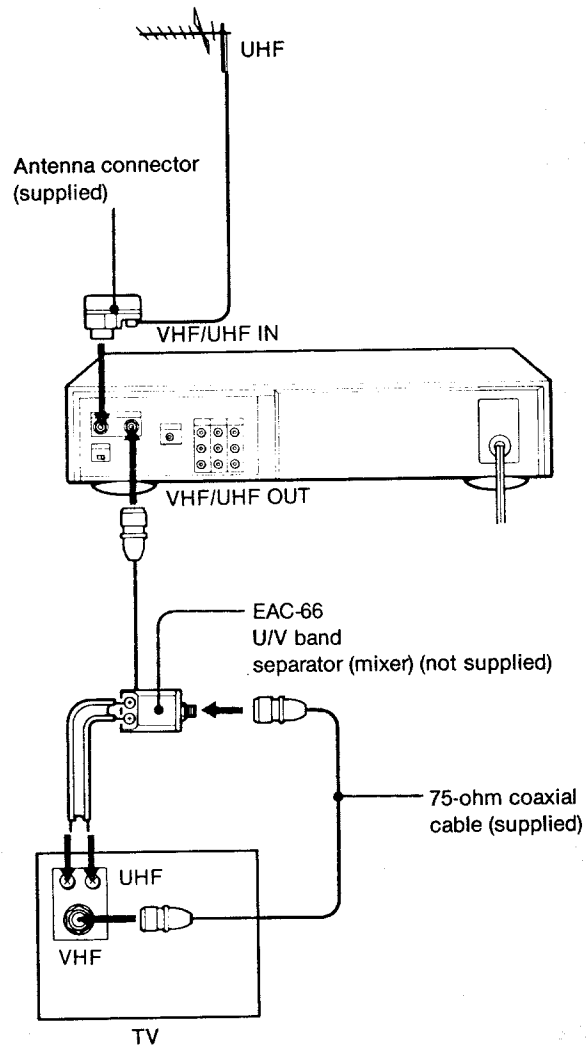

- 1 Attach the supplied antenna connector to the cable.
- 2 Attach the antenna connector to VHF/UHF IN on the VCR.
- 3 Attach the EAC-66 U/V band separator to VHF/UHF OUT on the VCR.
- 4 Connect the separator to the VHF and UHF antenna terminals on the TV.

How to attach the antenna connector and the U/V band separator

See page 17.

Connecting Example 4 To Connect Both the VHF and UHF Antennas

A If the VHF/UHF antenna terminal on the TV is combined

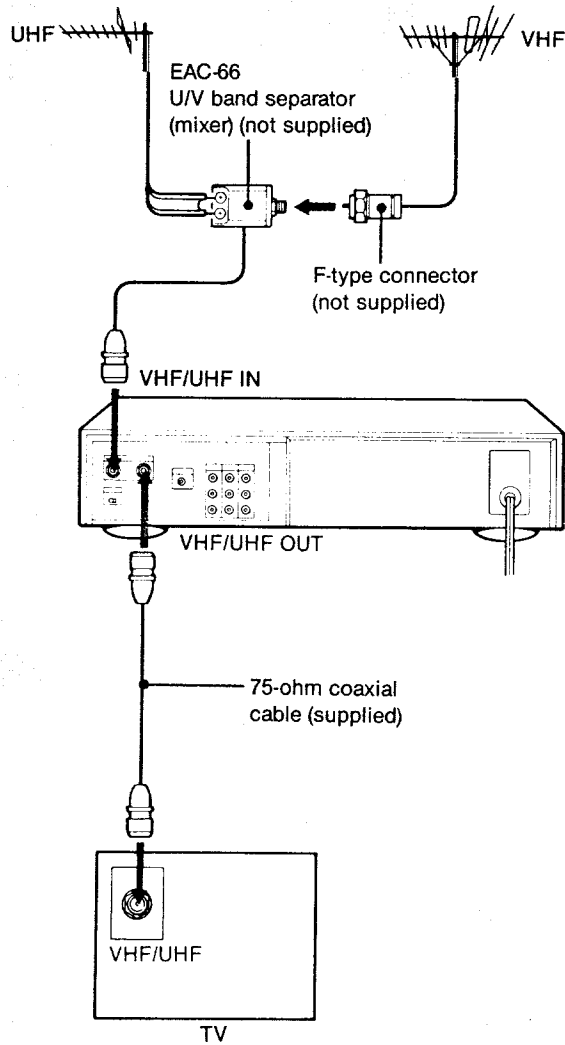

- 1 Attach a U/V band separator (mixer) with the VHF and UHF antennas to VHF/UHF IN on the VCR.
- 2 Connect VHF/UHF OUT on the VCR and the VHF/UHF antenna terminal on the TV.

B If the VHF/UHF antenna terminals on the TV are separated

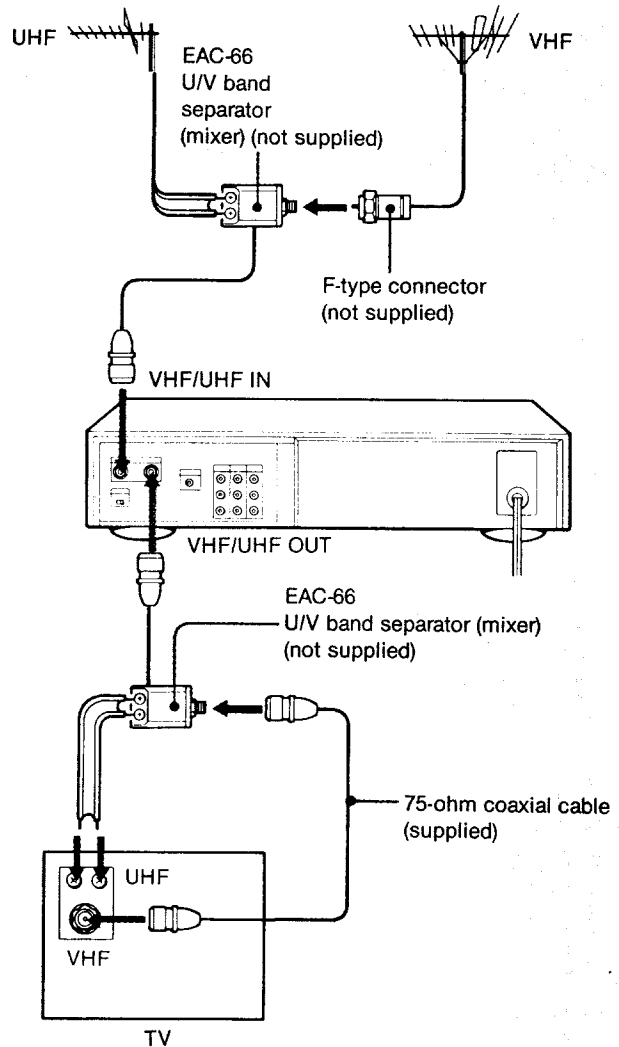

- 1 Attach an U/V band separator (mixer) with the VHF and UHF antennas to VHF/UHF IN on the VCR.
- 2 Attach an U/V band separator to VHF/UHF OUT on the VCR.
- 3 Connect the separator to the VHF and UHF antenna terminals on the TV.

How to attach a U/V band separator and an F-type connector

See page 17.

Connecting Example 5
To Connect a Cable TV System

A If your TV set has a built-in CATV decoder

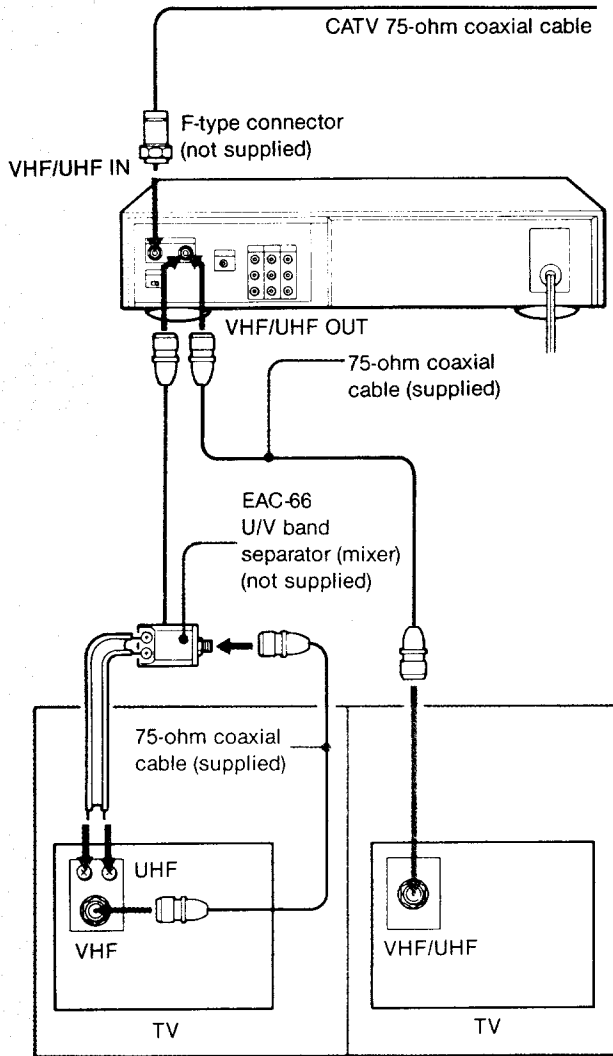

A connecting example is given above, however you should consult your cable company to make sure that the cable is properly connected.

B If your TV set does not have a built-in CATV decoder

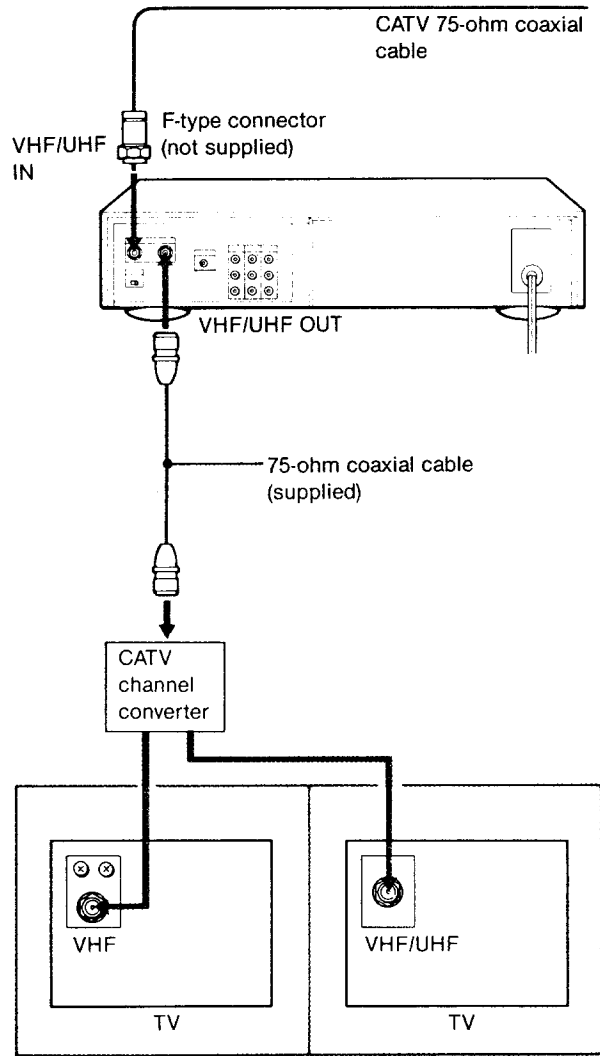

Connect the cable TV channel converter between the TV and the VCR.

By setting ANT TV/VTR to TV, you can watch a cable TV program while playing back or recording video sources using LINE IN VIDEO on the VCR.

Note to CATV system installer in the U.S.A

This reminder is provided to call the cable TV system installer's attention to Article 820-22 of the NEC that provides guidelines for proper grounding and, in particular, specifies that the cable ground shall be connected to the grounding system of the building, as close to the point of cable entry as practical.

Attaching an F-type connector (not supplied)

- 1 Strip the cover of the cable so that 3/8 inch of the center conductor is exposed.

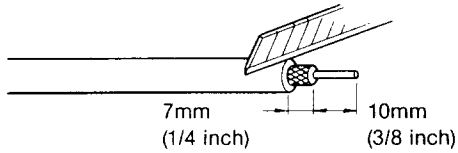

- 2 Slip the crimping ring over the cable and fold back the shield.

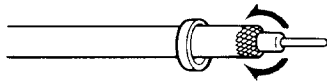

- 3 Insert the inner conductor into the F-type connector shaft and push the end of the cable into the connector as far as it will go.

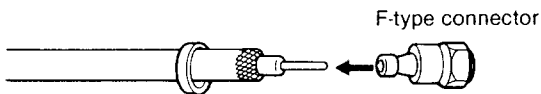

- 4 Slide the crimping ring over this assembly and pinch the crimping ring with pliers to hold the connector in place.

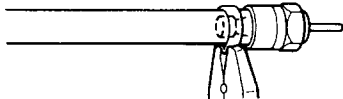

- 5 Cut the center conductor.

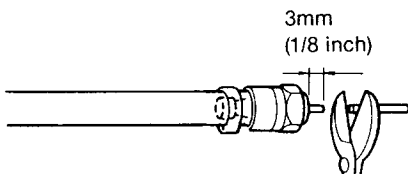

- 6 Insert the F-type connector into VHF/UHF IN on the VCR.

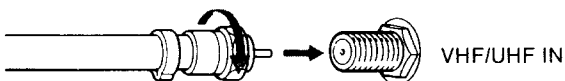

Attaching an external antenna connector (supplied)

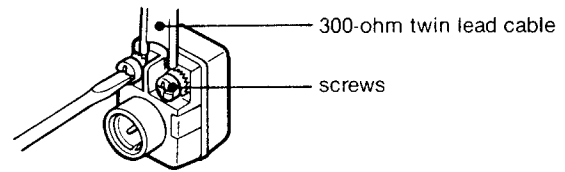

- 1 Loosen the screws on the antenna connector.
- 2 Fit the 300-ohm twin lead cable on the UHF antenna under the screws on antenna connector.
- 3 Tighten the screws again.

Attaching an EAC-66 U/V band separator (mixer) (not supplied)

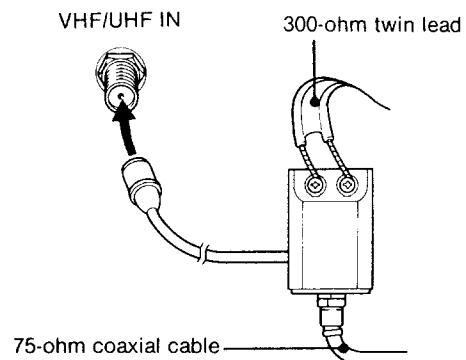

- 1 Loosen the screws on the U/V band separator.
- 2 Fit the 300-ohm twin lead cable on the UHF antenna under the screws.
- 3 Connect the 75-ohm coaxial cable to the U/V band separator.
- 4 Connect the U/V band separator to VHF/UHF IN on the VCR.

Connecting Example 6 To Connect a TV Equipped with Video/Audio Input Jacks

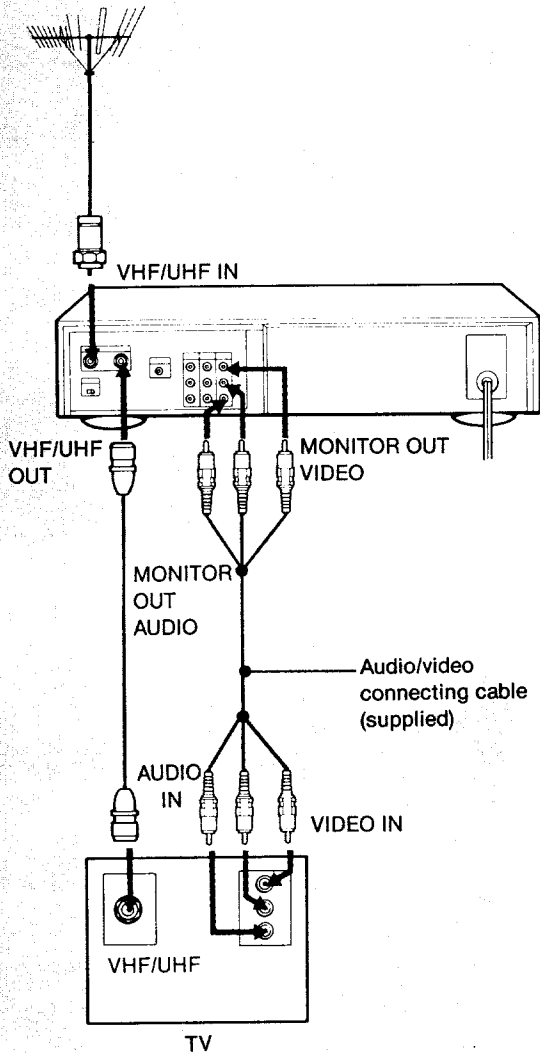

If your TV has video/audio input jacks, connect them to the MONITOR OUT jacks on the VCR to obtain a higher quality picture.

- 1 Make connections between an antenna and VHF/UHF IN on the VCR, and between VHF/UHF OUT on the VCR and the antenna terminal on the TV following examples 1 to 5.
- 2 Connect MONITOR OUT on the VCR and the video/audio input jacks on the TV with the supplied audio/video connecting cable.

Connecting Example 7 To Connect an Audio System

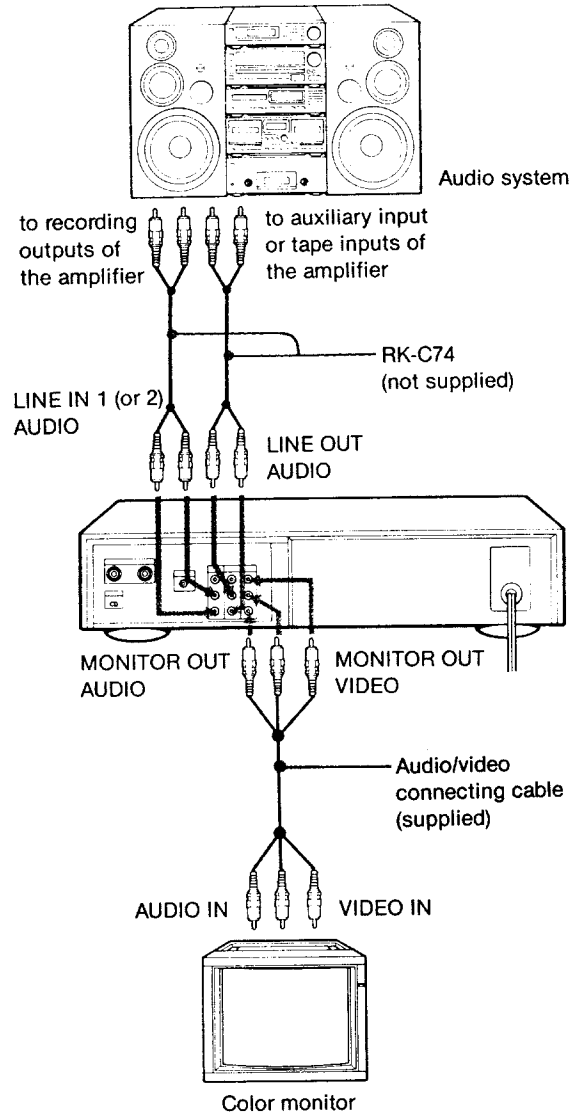

You can enjoy tapes recorded in hi-fi stereo when the VCR is connected to your audio system.

Notes

- If the VCR is installed near a tuner or a radio, noise may be heard in AM reception. In this case, move the VCR away from the tuner or the radio, adjust the AM antenna for minimum noise, or connect an external AM antenna to the tuner.
- Since a hi-fi recorded tape has a wide dynamic range, turn down the volume on the amplifier before playing back the tape to avoid damaging the speakers.
- Before connecting or disconnecting the power cord of the VCR, be sure to turn off the connected amplifier.

Adjusting a TV

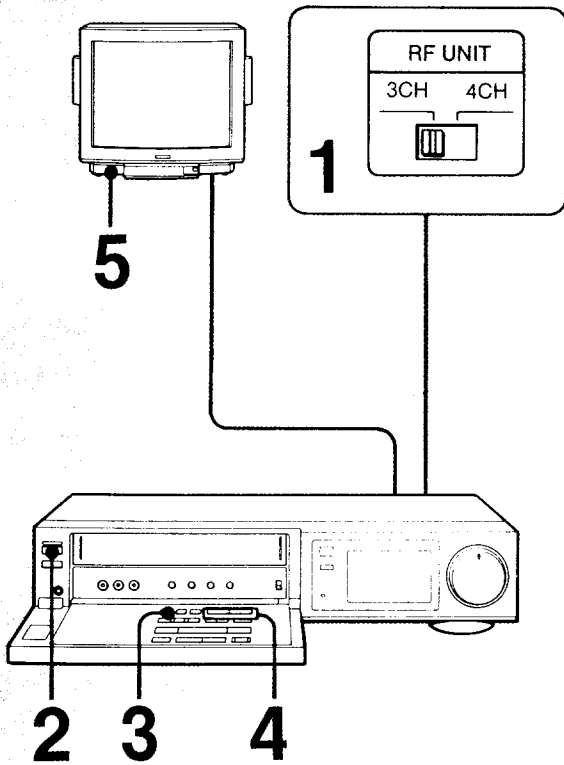

If you have connected your VCR and TV via antenna terminals only, either channel 3 or 4 must be selected on your TV to receive the signal from the VCR. To get the proper RF signal, set the RF UNIT selector on the rear panel of the VCR.

If the connection between the VCR and TV has been made via video/audio jacks, skip this step.

- 1** Set **RF UNIT** to 3 CH or 4 CH.
If channel 4 is active in your area, set the selector to channel 3, and vice versa.
- 2** Press **POWER**.
The indicator lights.
- 3** Press **ANT TV/VTR** so that the VTR indicator lights.
- 4** Check that the **TUNER** indicator appears in the display window, then select an active channel in your area by pressing **CHANNEL +/-**.
- 5** Turn on the TV and select either VHF channel 3 or 4 whichever was set on RF UNIT.
The TV program selected on the VCR appears on the TV screen.

Your TV is now tuned to receive the signal from the VCR. Whenever you use the VCR, select the channel you choose above on the TV.

Note

For details about TV channel setting, see the instruction manual of the TV.

Menu System

Many of the operations on this VCR are performed using a menu system. In this system you select a desired item from the items displayed on the TV screen.

First display the main MENU and select the item you want to operate or preset.

How to Display the Main MENU

Before you begin

- Check the connection between the VCR and the TV.
- If your TV is equipped with video/audio input jacks, be sure to connect them to MONITOR OUT on the VCR for on-screen display. On-screen display does not appear if the TV is connected to LINE OUT VIDEO.

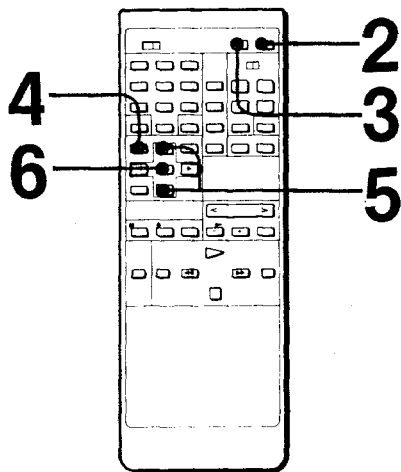
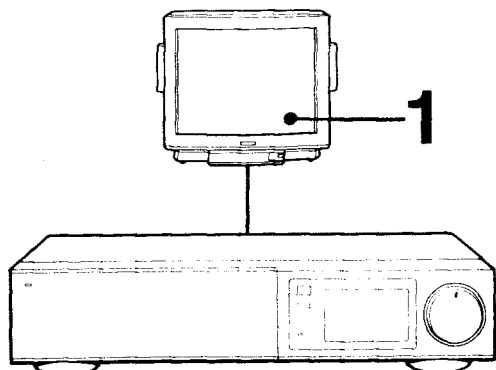

To erase the menu display

Press **MENU** again.

To display another menu display

Press **MENU** to erase the present menu and repeat steps 4 to 6.

Operation

- 1 Turn on the TV.
If your TV is equipped with video/audio input jacks
 Select the input for the VCR.
If your TV is not equipped with video/audio input jacks
 Select the channel for the VCR (3 or 4).

- 2 Press **POWER**.

- 3 Press **ANT TV/VTR** so that the VTR indicator lights.
 (Only for TV without video/audio input jacks)

- 4 Press **MENU**.
 The main MENU appears.

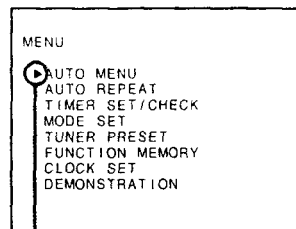

Cursor

- 5 Move cursor to the desired menu with **▲** or **▼**.

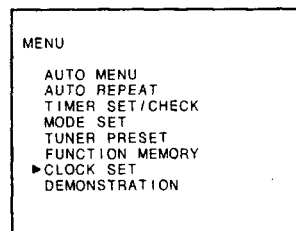

- 6 Press **EXECUTE**.
 The selected menu display appears.

Example

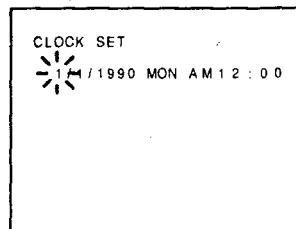

Note

The position of the cursor is stored unless the power plug is disconnected.

About Each MENU

Here is a list of the menus that can be selected from the main MENU.

For details, refer to the sections indicated.

AUTO MENU

Select the desired automatic tape operation.

See "Presetting a Sequential Tape Operation". (page 34)

AUTO REPEAT

Select the portion which you want to play back repeatedly.

See "Playing Back a Tape Repeatedly". (page 36)

TIMER SET/CHECK

Preset the timer recording and check the contents.

See "Timer Recording". (page 44)

MODE SET

Set the desired mode.

See "Mode Setting". (page 22)

TUNER PRESET

Preset the active channels in your area.

See "Presetting Active Channels". (page 26)

FUNCTION MEMORY

Store one of the automatic tape operations to the FUNCTION MEMORY button on the Commander. You can activate the operation simply by pressing FUNCTION MEMORY.

See "Storing a Desired Tape Operation to the FUNCTION MEMORY Button". (page 35)

CLOCK SET

Set the date and clock.

See "Date and Clock Setting". (page 24)

DEMONSTRATION

Select to display each menu and examples of TIMER TITLE and TIMER SET/CHECK in sequence, as follows.

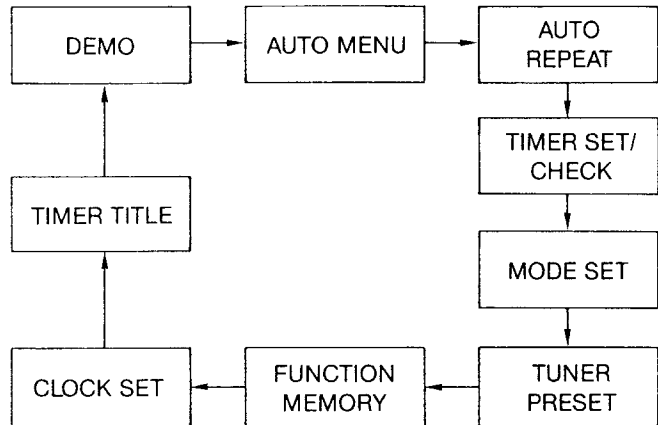

- Press **EXECUTE** to stop at the desired display.
- Press any key except **EXECUTE** to get out of the DEMONSTRATION mode.

Mode Setting

Before operating the VCR, change various mode settings if necessary.

Operation

Use ▲ and ▼ to move cursor.
Use ► and ◀ to move dot.

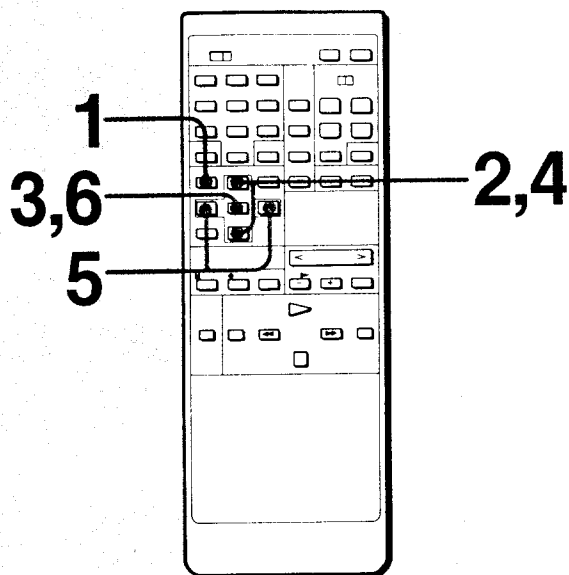

1 Press **MENU**.
The main MENU appears.

2 Move cursor to **MODE SET**.

```
MENU
AUTO MENU
AUTO REPEAT
TIMER SET/CHECK
▶MODE SET
TUNER PRESET
FUNCTION MEMORY
CLOCK SET
DEMONSTRATION
```

3 Press **EXECUTE**.
The **MODE SET [PAGE 1]** menu appears.

```
MODE SET [PAGE 1]
▶AUTO ANT SEL  *ON OFF
AUTO STEREO  *ON OFF
CLOCK DISPLAY *ON OFF
DIMMER       ON  *OFF
NORMAL AUDIO *MAIN SAP
BACK COLOR  *BL GR P K
NEXT PAGE
```

To display **MODE SET [PAGE 2]** menu
Move cursor to **NEXT PAGE** and press **EXECUTE**.

```
MODE SET [PAGE 2]
▶TIMER TITLE  *ON OFF
TIMER REC-REW ON *OFF
AUDIO MIX    ON  *OFF
PREVIOUS PAGE
```

To return to the **[PAGE 1]** menu, move cursor to **PREVIOUS PAGE** and press **EXECUTE**.

Note

The displayed page is stored unless the power plug is disconnected.

4 Move cursor to the desired mode.

MODE SET [PAGE 1] menus

AUTO ANT SEL (Automatic Antenna Selector)

• **If your TV is not equipped with video/audio inputs**

Set to ON.

When playing back a tape, the picture is automatically displayed on the screen simply by selecting the channel for the VCR on the TV.

To watch TV programs selected on the TV, press **ANT TV/VTR** to turn off the VTR indicator in the display window.

• **If your TV is equipped with video/audio inputs**

Set to OFF.

When playing back a tape, select the input for the VCR on the TV.

To watch TV programs selected on the TV, simply select the tuner input.

AUTO STEREO

If a stereo program received is noisy, set to OFF. The program is recorded in monaural but noise may be reduced.

CLOCK DISPLAY

To erase the current date and time from on-screen display, set to OFF.

DIMMER

To dim the display window, set to ON.

NORMAL AUDIO

When there is a SAP (Second Audio Program) broadcast, select SAP to record the SAP sound on the normal audio track. For details, see page 41.

BACK COLOR

Select the background color on the screen when no picture is displayed or the menu display is shown on the screen.

BL...blue

GR...green

PK...pink

MODE SET [PAGE 2] menus

TIMER TITLE

If you do not want to record a timer title consisting of date of recording, etc. on the tape before timer recording, set to OFF. For details, see page 51.

TIMER REC – REWIND

To automatically rewind the tape to recording start point after timer recording, set to ON. For details, see page 46.

AUDIO MIX

To listen to the sounds recorded on both the hi-fi video track and the normal audio track of the audio-inserted tape, set to ON. For details, see page 33.

5 Move dot to the desired setting.

6 Press **EXECUTE** to return to the original screen. The settings are stored.

Date and Clock Setting

You can set the date and clock on the TV screen with the Remote Commander.

Example: To set to June 26, 1990 3:32 PM

Use ▲ and ▼ to change the numbers.
Use ► and ◀ to change the blinking position.

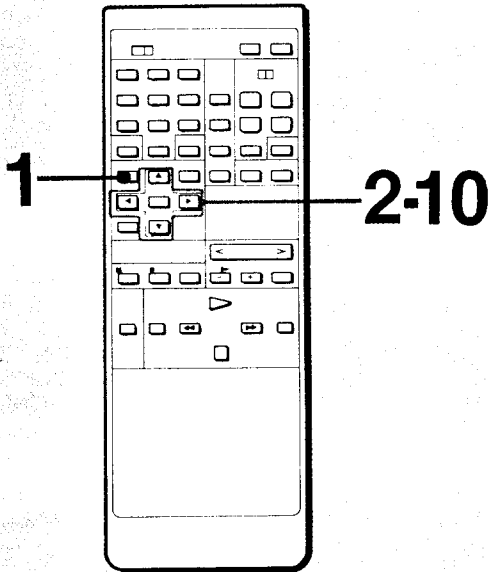

- 1** Press **MENU**.
The main MENU appears.

```
MENU
▶AUTO MENU
  AUTO REPEAT
  TIMER SET/CHECK
  MODE SET
  TUNER PRESET
  FUNCTION MEMORY
  CLOCK SET
  DEMONSTRATION
```

- 2** Move cursor to **CLOCK SET**.

```
MENU
  AUTO MENU
  AUTO REPEAT
  TIMER SET/CHECK
  MODE SET
  TUNER PRESET
  FUNCTION MEMORY
▶CLOCK SET
  DEMONSTRATION
```

- 3** Press **EXECUTE**.
"1/1 1990 MON AM 12:00" appears. The month is blinking.

```
CLOCK SET
  1/1 /1990 MON AM 12:00
```

- 4** Press ▲ until **6** appears.

```
CLOCK SET
  6-1 /1990 FRI AM 12:00
```

- 5** Press ► to make the day blink.

```
CLOCK SET
  6-1 /1990 FRI AM 12:00
```

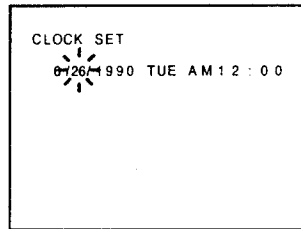

6 Press **▲** until 26 appears.

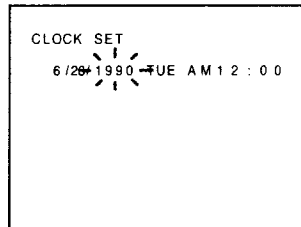

7 Press **▶** to make the year blink and press **▲** to change the year if necessary.

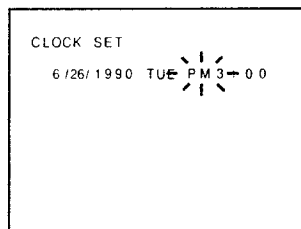

8 Press **▶** to make the hour blink and press **▲** or **▼** until PM 3: appears.



9 Press **▶** to make the minute blink and press **▲** or **▼** until 32 appears.

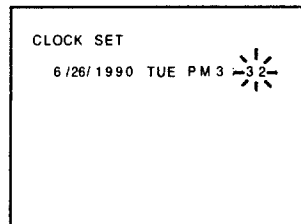

10 Press **EXECUTE** to return to the original screen. (For accurate setting, press **EXECUTE** at the same time with an announced time signal.) The current date and time are displayed on the screen.

To erase the current date and time from the on-screen display

- 1 Press **MENU**.
The main MENU appears.
- 2 Move cursor to MODE SET and press **EXECUTE**.
The MODE SET menu appears.
- 3 Move cursor to CLOCK DISPLAY.
- 4 Move dot to OFF with **▶** or **◀**.
- 5 Press **EXECUTE** to return to the original screen.
The date and clock are not displayed on the screen.

Notes

- You can perform clock setting except during timer recording, timer recording stand-by or quick timer recording.
- When you call up the CLOCK SET display, the clock keeps running and as long as the time is not changed, the seconds will not be reset to 00 when you return to the original screen.

Presetting Active Channels

This VCR is capable of receiving VHF/UHF channels 2 to 69 and CATV channels 1 to 125. You can preset all receivable channels automatically by automatic presetting so that they appear in numerical sequence when you press **CHANNEL +/-**. If there are unwanted channels, you can erase them manually or if you know the channel numbers to be preset, you can preset them manually so that only the desired channels appear when you press **CHANNEL +/-**.

Before Presetting Channels

- Turn on the VCR and the TV.
- If your TV is not equipped with video/audio input jacks, set the TV to the correct channel (3 or 4) for the VCR and press **ANT TV/VTR** to display the VTR indicator.
- If your TV is equipped with video/audio input jacks, select the video input on the TV.
- The on-screen display does not appear unless the TV is connected to **MONITOR OUT** on this VCR.
- Press **INPUT SELECT** so that the **TUNER** indicator and the channel number appear in the display window.

To Preset All Receivable Channels Automatically

Use **▲** and **▼** to move cursor.
Use **▶** and **◀** to move dot.

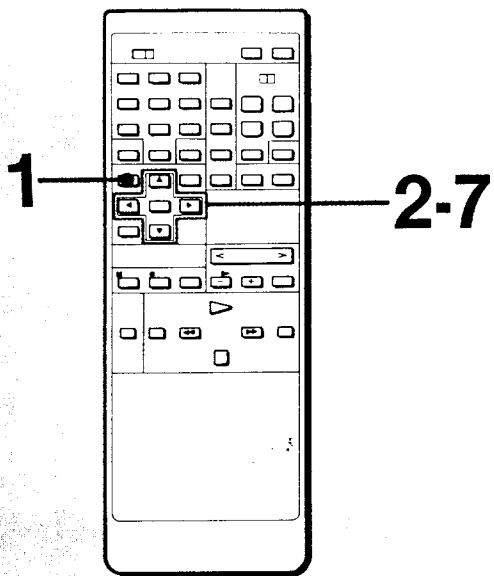

- 1 Press **MENU**.
The main **MENU** appears.

```

MENU
▶AUTO MENU
  AUTO REPEAT
  TIMER SET/CHECK
  MODE SET
  TUNER PRESET
  FUNCTION MEMORY
  CLOCK SET
  DEMONSTRATION
    
```

- 2 Move cursor to **TUNER PRESET**.

```

MENU
  AUTO MENU
  AUTO REPEAT
  TIMER SET/CHECK
  MODE SET
▶TUNER PRESET
  FUNCTION MEMORY
  CLOCK SET
  DEMONSTRATION
    
```

- 3 Press **EXECUTE**.
The **TUNER PRESET** display appears.

```

TUNER PRESET          2 CH
NORMAL / CATV • NORM  CATV
AUTO PRESET
▶MANUAL SET • ADD    ERASE
AFT          • ON    OFF
FINE TUNING
    
```

- 4** Move cursor to **▶**.
NORMAL/CATV.

```
TUNER PRESET          2 CH
▶NORMAL / CATV •NORM  CATV
AUTO PRESET
MANUAL SET •ADD  ERASE
AFT          •ON  OFF
FINE TUNING
```

- 5** Move dot to NORM to preset VHF and UHF channels.
Move dot to CATV to preset cable TV channels.
The lowest channel number appears.
NORM: 2
CATV: 1

```
TUNER PRESET          2 CH
▶NORMAL / CATV •NORM  CATV
AUTO PRESET
MANUAL SET •ADD  ERASE
AFT          •ON  OFF
FINE TUNING
```

- 6** Move cursor to AUTO
PRESET.

```
TUNER PRESET          2 CH
  NORMAL / CATV •NORM  CATV
▶AUTO PRESET
MANUAL SET •ADD  ERASE
AFT          •ON  OFF
FINE TUNING
```

- 7** Press **EXECUTE**.
Receivable channels are automatically preset in
numerical sequence.
When no more channels can be found, the presetting
stops and the lowest numbered channel appears.

To Erase Unnecessary Channels

- 1** After automatic presetting is over, follow steps 1 to 3 in "To Preset All Receivable Channels Automatically."
- 2** Press **CHANNEL + / -** or **the channel number button(s)** and **ENTER** to select the channel to be erased.
- 3** Move cursor to MANUAL SET and select ERASE.
- 4** Press **EXECUTE**.
When pressing **CHANNEL + / -**, the erased channel is skipped.

Repeat steps 2 and 3 for other channels to be erased before pressing **EXECUTE**.

To Resume Erased Channel or Add a New Channel

- 1** Follow steps 1 to 3 in "To Preset All Receivable Channels Automatically."
- 2** Select the channel to be added with **the channel number button(s)** and **ENTER**.
- 3** Move cursor to MANUAL SET and select ADD.
- 4** Press **EXECUTE**.
When pressing **CHANNEL + / -**, the added channel appears.

Repeat steps 2 and 3 for other channels to be added before pressing **EXECUTE**.

Presetting Active Channels

Fine-tuning a Received Channel

Normally the AFT (Auto Fine Tuning) function works and the VCR automatically tunes the received channels. If the picture of a received channel is distorted due to signal interference, fine-tune manually.

- 1 Follow steps 1 to 3 on page 26.
- 2 Move cursor to FINE TUNING.
The fine tuning indicator appears.

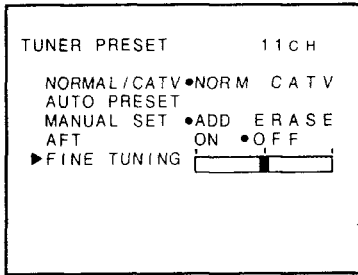

- 3 Fine-tune with ▶ or ◀ to get a clear picture.
If you cannot get a better picture, move cursor to AFT and select ON.
- 4 Press EXECUTE.

About the FINE TUNING indicator

The FINE TUNING indicator shows the operable extent of the fine tuning.

- When the VCR is receiving a broadcast in the best condition, the indicator is at the center or one space right or left of the center.
- Even if the VCR is receiving the broadcast in the best condition, it may happen that the indicator is not at the center.
- When the VCR is receiving input signal from a video game, the indicator may be off the center even though the VCR is receiving it in the best condition.

Cable TV Channel Assignment

Cable TV systems use letters or numbers to designate the channels. To tune-in a CATV channel, refer to the chart below which shows the CATV channel numbers on this VCR and the corresponding CATV channels. Note that the channel number assignment shown in the chart may not correspond to the channel number used by your local cable company. Check with your local cable TV company for more information on the available channels.

Number on this VCR	1	2	...	13	14	15	16	17	18				
Corresponding CATV channel	A-8	2	...	13	A	B	C	D	E				
19	20	21	22	23	24	25	26	27	28	29	30	31	32
F	G	H	I	J	K	L	M	N	O	P	Q	R	S
33	34	35	36	37	...	94	95	96	97	98	99		
T	U	V	W	W+1	...	W+58	A-5	A-4	A-3	A-2	A-1		
100	...	125											
W+59	...	W+84											

Cable TV services may vary from area to area. This VCR is designed to correspond to the Standard cable system but is capable of receiving the HRC*¹ or IRC*² system in optimum conditions.

*1 HRC (Harmonic Related Carriers)

All channels except for 5 and 6 are 1250 kHz lower than the Standard cable system. Channel 5 and 6 are 750 kHz higher than the Standard cable system.

*2 IRC (Incremental Related Carriers)

All channels except for 5 and 6 are the same as the Standard cable system. Channels 5 and 6 are 2000 kHz higher than the Standard cable system.

Note on the HRC and IRC cable systems

When this VCR is receiving a channel in the HRC or IRC cable system which differs in frequency from the Standard cable system, the FINE TUNING indicator may be off the center even if the signals are received in good condition.

Note

Pay cable TV systems use scrambled or encoded signals and require special converters (decoders) in addition to the normal cable connection.

Handling Video Cassettes

Inserting a Cassette

Insert a cassette fully into the compartment by slowly pressing its center with the arrow indication facing upwards.

Even if the power is turned off, the power will be automatically turned on.

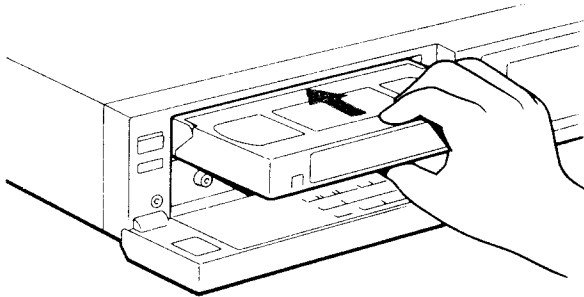

Ejecting a Cassette

Press **EJECT** to eject the cassette. As long as the AC power cord is connected to the wall outlet, you can eject the cassette even when the power of the VCR is turned off. After the tape is ejected, the power is automatically turned off.

To Avoid Erasing Previously Recorded Video Contents

When you make a new recording on a previously recorded cassette, the previous recording is automatically erased. To avoid unintentional erasure of previously recorded video sources, break off the safety tab on the cassette. To re-record on the cassette, cover the slot where the safety tab used to be located with plastic tape.

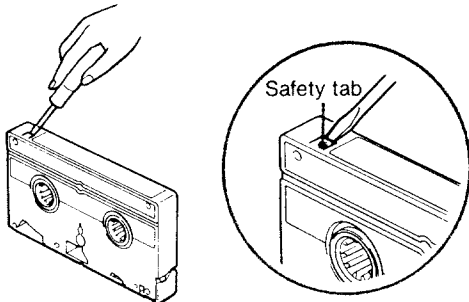

Maximum Recording Time of a Tape

Recording in the SP or EP mode is possible with this VCR.

When recording, select the desired recording time (SP or EP) with **REC MODE** on the Remote Commander or the VCR.

During playback, the VCR automatically detects the recording format, and then plays it back in the appropriate mode.

An SP Tape runs three times as fast as an EP tape does. In playback mode, LP mode is possible. But you cannot record in LP mode.

Refer to the chart below for the recording/playback time available in each mode.

REC MODE setting	Cassette tape			
	T-160	T-120	T-60	T-30
SP (standard)	2 hr. 40 min.	2 hr.	1 hr.	30 min
EP	8 hr.	6 hr.	3 hr.	1 hr. 30 min.

Note on tapes recorded in LP mode

Playback of tapes recorded in LP mode is possible with this VCR. However, playback in modes other than normal speed forward is not guaranteed.

Playing a Tape

Basic Playback

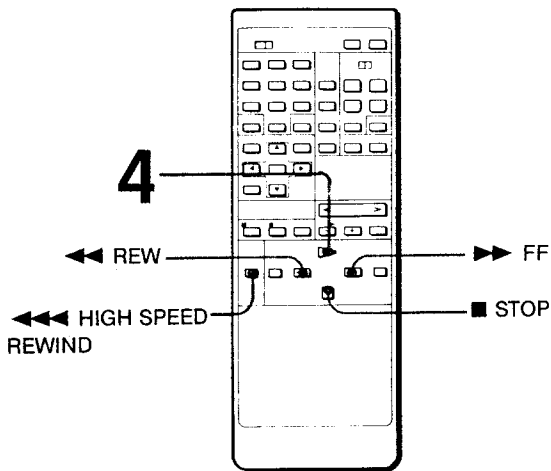
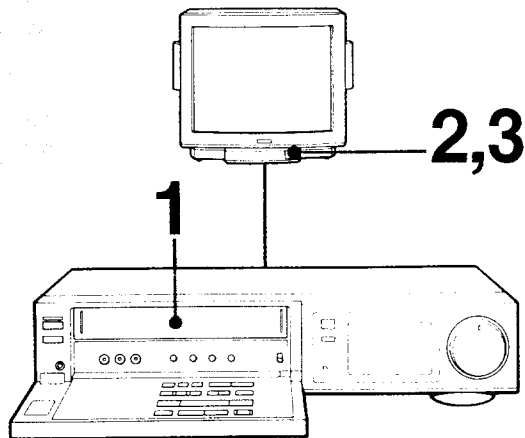

- 1** Insert a cassette.
- 2** Turn on the TV.
- 3** If your TV is equipped with video/audio input jacks
Select the input for the VCR.
If your TV is not equipped with video/audio input jacks
Select the channel for the VCR (3 or 4).
- 4** Press ► PLAY.

To stop playback, press ■ STOP.

To advance the tape rapidly, press ►► FF.

To rewind the tape, press ◀◀ REW.

To rewind the tape at high speed, press ◀◀◀ HIGH SPEED REWIND.

If you insert the cassette with its safety tab removed, playback starts automatically.

When the tape is played back to the end, the tape is automatically rewound to the beginning (auto rewind). The power remains on.

About the Data Screen

The data screen information is displayed on the screen.
To erase the data screen display, press **DATA SCREEN** on the Commander.
To erase only the current date and time, see page 25.

Notes

- If your TV is equipped with video/audio input jacks, the data screen is not displayed unless the TV is connected to MONITOR OUT on this VCR.
- When the VCR is in slow motion or still playback mode, the data screen does not appear.

Notes on the remaining tape length indicator

- The displayed remaining tape length is not precise. Use it only as an approximate reference.
- When you insert a short tape such as T-20, T-30 or a nonstandardized commercially available tape, this indicator may not function correctly.

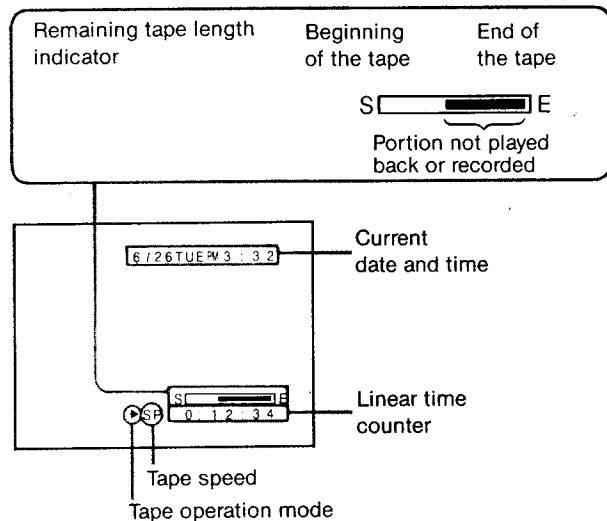

Various Playback Modes

To obtain a still picture

During playback mode press **||/▶ PAUSE/STILL** on the VCR or **|| PAUSE** on the Commander.

To return to normal playback, press **▶ PLAY** or **||/▶ PAUSE/STILL** or **|| PAUSE**.

When the pause mode lasts for more than 5 minutes, the VCR re-enters the playback mode automatically.

To search for a particular scene — Picture search

During playback mode, press **◀◀ REW** or **▶▶ FF**.

While the button is pressed, a high speed picture without sound appears on the TV screen.

When you release the button, the VCR returns to the previous mode.

To search for a particular scene — Locked picture search

During the playback mode, press **↔ SEARCH** or **↔ SEARCH** on the Commander.

A high speed picture in forward or reverse appears on the screen even when the button is released. To resume normal playback, press **▶ PLAY**.

To watch a slow motion playback

During playback mode, press **SLOW** on the Commander.

+ : To increase the speed

- : To decrease the speed

To view the picture momentarily while the VCR is in the fast-forward or rewind mode without picture on the TV screen

During fast-forward mode, press **▶▶ FF**.

During rewind mode, press **◀◀ REW**.

You can see a high speed playback picture while the button is pressed. Release the button to return to the previous mode.

To view a playback picture at 2 times the normal speed

During playback mode, press **x2** on the Commander.

Press **▶ PLAY** to resume normal playback.

To view reverse direction playback, slow and x2 picture

During forward playback of the desired mode, press **< DIRECTION** on the Commander. Press **▶ PLAY** or **>** to resume forward playback.

To watch a frame-by-frame picture

During still mode, press **> DIRECTION** to advance the picture one frame. Press **<** to reverse the picture one frame. Each press of **<** or **>** moves the picture one frame. Press **▶ PLAY** to resume normal playback.

Various playback modes using SWING SHUTTLE

When the VCR is in any playback mode, you can select various playback modes with SWING SHUTTLE on the VCR; $\times 1/5$, $\times 1$, $\times 2$, picture search. The same speed is available in the reverse direction. When you release the ring, the VCR enters the playback pause mode.

If streaks or noise appear in a slow motion picture

Adjust **TRACKING NORMAL/SLOW** and **STILL**

ADJUST inside the front panel of the VCR.

You can adjust the picture more easily at speeds closer to normal playback.

If the picture appears to shake in the still mode

Adjust **TRACKING NORMAL/SLOW** and **STILL**

ADJUST until the picture stabilizes.

If a noise band appears on the top or bottom of the picture in the still mode

Change to the slow motion mode, and then adjust **TRACKING NORMAL/SLOW** and **STILL ADJUST**.

Notes

- When the tape recorded in the LP mode is played back in one of various playback modes, the noise may appear.
- Streaks or noise cannot be eliminated completely in reverse playback or reverse slow motion playback mode.

Adjusting the Picture during Normal Playback

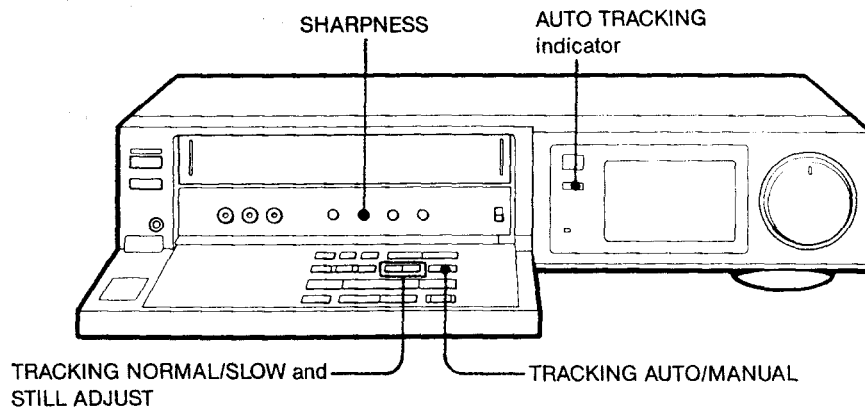

Automatic tracking function

The tracking condition is automatically adjusted on this VCR. The AUTO TRACKING indicator blinks while the VCR is searching for the best tracking condition and lights when optimum playback picture is obtained. The automatic tracking control is activated in the following conditions:

- when the cassette is inserted and played back.
- when the recording mode on the playback tape is switched between SP and EP.
- when the picture is distorted by scratches etc. on the tape.
- when the AUTO TRACKING indicator is turned on by pressing TRACKING AUTO/MANUAL after the picture is adjusted manually. (See Manual tracking adjustment.)

Notes

- Auto tracking adjustment may be impossible and the tracking indicator does not appear on the TV screen when the recording condition of the tape is poor.
- During auto tracking adjustment, streaks or noise may appear.
- If the TV or color monitor is not connected to the VHF/UHF OUT connector or the MONITOR OUT AUDIO/VIDEO jacks, on-screen display cannot be obtained.
- When **DATA SCREEN** on the Commander is pressed, the tracking indicator does not appear on the TV screen.

Manual tracking adjustment

If streaks or snow appear during normal playback, adjust the picture with **TRACKING NORMAL/SLOW and STILL ADJUST ▼/▲**.

The tracking indicator appears on the TV screen and the AUTO TRACKING indicator on the VCR is turned off. Press either ▼ or ▲ to get the optimum picture.

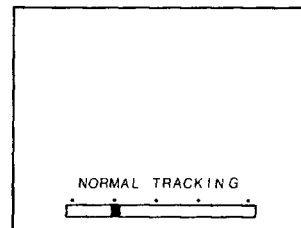

Press both ▼ and ▲ buttons simultaneously to return to the tracking center position.

Adjusting the sharpness

Turn **SHARPNESS** toward SHARP to get a sharper picture. Turn it toward SOFT to get a softer picture.

Selecting the Monitor Sound

You can play back tapes on which stereo sound programs or bilingual programs are recorded on the VCR.

Press **AUDIO MONITOR** to select the desired sound. Each press of the button changes the display.

Display	Sound to be heard	
	Stereo tape	Bilingual tape
STEREO	Stereo	Left and right channels
MAIN/L	Left channel	Left channel
SUB/R	Right channel	Right channel
None	Monaural (on normal audio track)	Sound on normal audio track (SAP)

Note

When you play back a tape recorded in monaural, the sound is heard in monaural regardless of the setting of **AUDIO MONITOR**.

Listening to the Sounds on the Hi-fi Track and Normal Track Mixed

You can hear the sounds recorded on the hi-fi video track and the normal audio track simultaneously. This allows you to listen to an audio-inserted tape.

Use ▲ and ▼ to move cursor.
Use ► and ◀ to move dot.

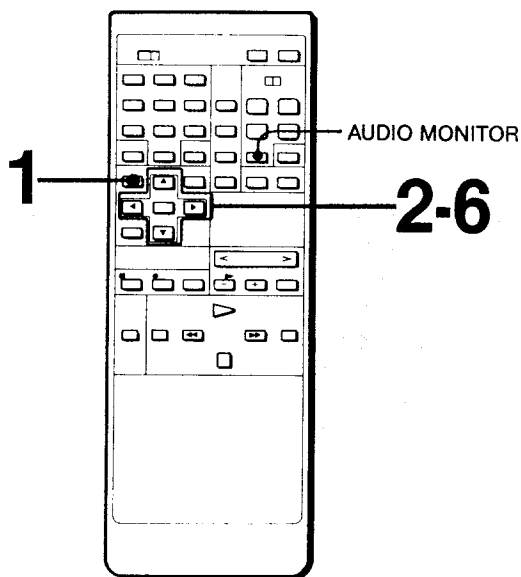

Note

When you set **AUDIO MIX** to **ON**, the **AUDIO MONITOR** button does not function. Reset to **OFF** after listening to the sound in **AUDIO MIX** mode.

1 Press **MENU**.
The main **MENU** appears.

2 Move cursor to **MODE SET**.

3 Press **EXECUTE**.
If the **MODE SET [PAGE 1]** menu appears, move cursor to **NEXT PAGE** and press **EXECUTE**.
The **MODE SET [PAGE 2]** menu is displayed.

```
MODE SET [PAGE 2]
▶TIMER TITLE   *ON OFF
TIMER REC-REW ON *OFF
AUDIO MIX      ON *OFF
PREVIOUS PAGE
```

4 Move cursor to **AUDIO MIX**.

5 Move dot to **ON**.

```
MODE SET [PAGE 2]
TIMER TITLE   *ON OFF
TIMER REC-REW ON *OFF
▶AUDIO MIX    *ON OFF
PREVIOUS PAGE
```

6 Press **EXECUTE** to return to the original screen.

Presetting a Sequential Tape Operation — AUTO MENU

By assigning the desired tape operation combination using the menu system, a tape operation of several steps is automatically performed.

Use ▲ and ▼ to move cursor.

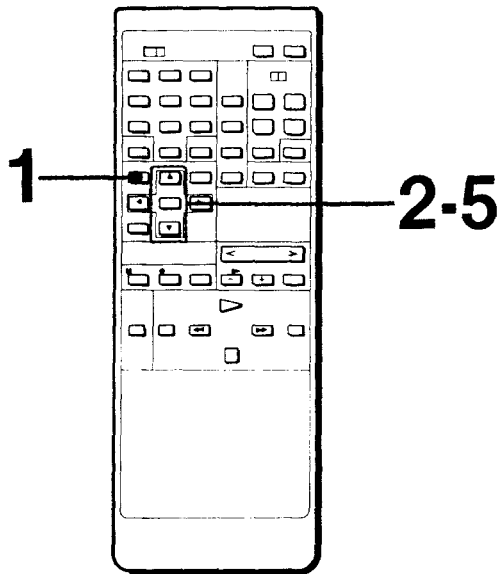

1 Press **MENU** when the tape is in stop mode.
The main MENU appears.

2 Move cursor to AUTO MENU.

3 Press **EXECUTE**.
The AUTO MENU appears.

```
AUTO MENU
▶PLAY-REW-POWER OFF
GO TO ZERO-STOP
GO TO ZERO-PLAY
GO TO REC START PLAY
REW-POWER OFF
REW-EJECT-POWER OFF
REW-PLAY
REW-TIMER REC
```

4 Move cursor to the desired tape operation.

5 Press **EXECUTE**.
The selected tape operation starts and the indication is superimposed on the screen for several seconds.
The **AUTO** indicator lights in the display window during AUTO MENU operation.

To return to the original screen without executing the operation

Press **MENU**.

Even if the power is turned off

The cursor remains in its most recent position.

Note on "GO TO REC START - PLAY"

If you perform the following operations, the memory of the recording start position will be erased and "GO TO REC START - PLAY" is not operable.

- When you press **COUNTER RESET**.
- When you eject the cassette.
- When you press **◀◀ HIGH SPEED REWIND**.

Note on REW - EJECT - POWER OFF

If the VCR is installed in the video rack with the door closed, the cassette may not be ejected. Turn off the power to stop operation.

Storing a Desired Tape Operation to the FUNCTION MEMORY Button

One of the tape operations in AUTO MENU can be stored to the FUNCTION MEMORY button on the Commander. You can make the VCR enter the desired tape operation only by pressing **FUNCTION MEMORY**.

Use ▲ and ▼ to move cursor.

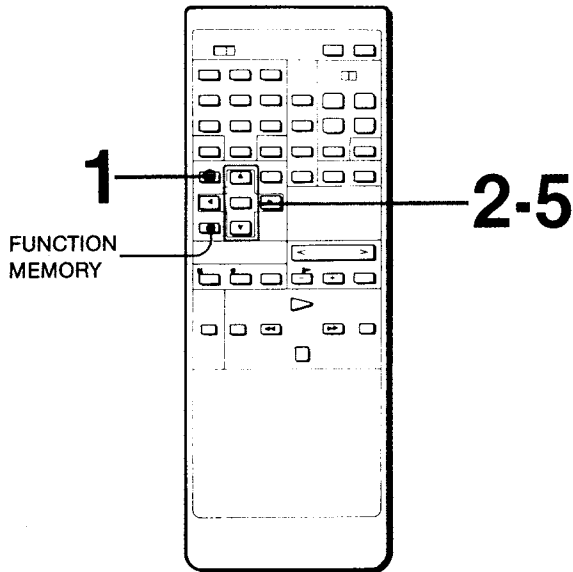

Note

This function is operable only when the tape is in stop mode.

- 1** Press **MENU**.
The main MENU appears.
- 2** Move cursor to **FUNCTION MEMORY**.
- 3** Press **EXECUTE**.
The **FUNCTION MEMORY** menu appears.
- 4** Move cursor to the desired tape operation.
- 5** Press **EXECUTE** to return to the original screen.

```

FUNCTION MEMORY
PLAY-REW-POWER OFF
GO TO ZERO-STOP
GO TO ZERO-PLAY
GO TO REC START PLAY
REW-POWER OFF
REW-EJECT-POWER OFF
REW-PLAY
▶[AUTO MENU]
    
```

Whenever you press **FUNCTION MEMORY** on the Commander, the stored tape operation starts automatically.

What does each AUTO MENU operation mean?

PLAY – REW – POWER OFF

The tape is played back to its end and rewound to its beginning. Then the power is turned off.

GO TO ZERO – STOP

The tape is fast-forwarded or rewound to around the counter zero point, and stops. See "Tape Return/Tape Return Play" (page 42) for detailed operation.

GO TO ZERO – PLAY

The tape is fast-forwarded or rewound to around the counter zero point, and is played back. See "Tape Return/Tape Return Play" (page 42) for detailed operation.

GO TO REC START – PLAY

The tape is fast-forwarded or rewound to the starting point of the recording, and is played back.

REW – POWER OFF

The tape is rewound to its beginning and the power is turned off.

REW – EJECT – POWER OFF

The tape is rewound to its beginning, and the cassette is ejected. Then the power is turned off.

REW – PLAY

The tape is rewound to its beginning and is played back.

REW – TIMER REC

The tape is rewound to its beginning and the VCR enters the standby mode for timer recording when a timer recording has been preset.

[AUTO MENU]

The AUTO MENU is displayed immediately after you press **FUNCTION MEMORY**, providing a short cut to the AUTO MENU.

Playing a Tape

Playing Back a Tape Repeatedly — AUTO REPEAT

You can set the VCR to repeat playback of a certain portion of the tape.

Use ▲ and ▼ to move cursor.

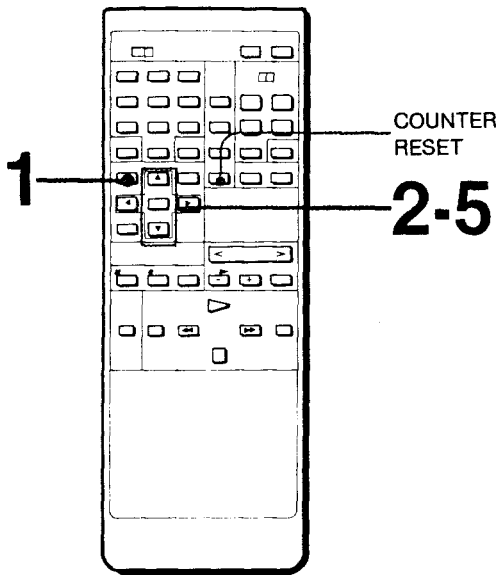

If you press any tape operation button during repeat playback

The auto repeat function is released.

1 Press **MENU** while the tape is in stop mode.
The main MENU appears.

2 Move cursor to AUTO REPEAT.

3 Press **EXECUTE**.
The AUTO REPEAT menu appears.

```
AUTO REPEAT
▶TAPE START - TAPE END
TAPE START - VIDEO END
TAPE START - COUNTER 0
COUNTER 0 - TAPE END
COUNTER 0 - VIDEO END
```

4 Move cursor to the portion you want to play back repeatedly.

5 Press **EXECUTE**.
The VCR automatically rewinds or advances the tape rapidly to the start point of the assigned repeat portion and repeats playback of that portion **five times**. Then the VCR rewinds the tape to the start point.
The **AUTO** indicator lights in the display window during repeat playback.

To stop playback

Press **■ STOP** on the VCR or the Commander.

What does each AUTO REPEAT menu mean?

TAPE START – TAPE END

The VCR repeats playback from the beginning to the end of the tape.

TAPE START – VIDEO END

The VCR repeats playback from the beginning of the tape to the end of the recorded portion.

TAPE START – COUNTER 0

The VCR repeats playback from the beginning of the tape to the counter zero point.

Before activating auto repeat function, press **COUNTER RESET** to set the tape counter to 0H00M00S at the end point of the portion to be played back repeatedly. See "Use of the tape counter". (page 42)

COUNTER 0 – TAPE END

The VCR repeats playback from the counter zero point to the end of the tape.

Before activating auto repeat function, press **COUNTER RESET** at the beginning of the portion you want to play back repeatedly.

COUNTER 0 – VIDEO END

The VCR repeats playback from the counter zero point to the end of the recorded portion of the tape.

Before activating auto repeat function, press **COUNTER RESET** at the beginning of the portion you want to play back repeatedly.

Note on "VIDEO END"

The VCR normally detects a blank of about 10 seconds on the tape as "VIDEO END". However, for about 30 seconds from the beginning of the tape, the VCR does not do this. Accordingly, the auto repeat function does not work correctly in the following cases.

- when there is a blank of more than 10 seconds in the assigned repeat portion (more than 40 seconds at the beginning of the tape).
- when there is a blank of less than 10 seconds after the recorded portion to be played back repeatedly.

When you assign the menu including VIDEO END

If the tape is recorded to its end, auto repeat function does not work. Assign the menu including TAPE END.

Recording TV Programs

Before You Begin

- Make sure that the connections and preparations are complete.
- Check that the REC LEVEL controls are set to the **5** position.

Caution

Television programs, films, video tapes and other materials may be copyrighted. Unauthorized recording of such material may be contrary to the provisions of the copyright laws. Also, use of this recorder with cable television transmission may require authorization from the cable television transmission and/or program owner.

Operation

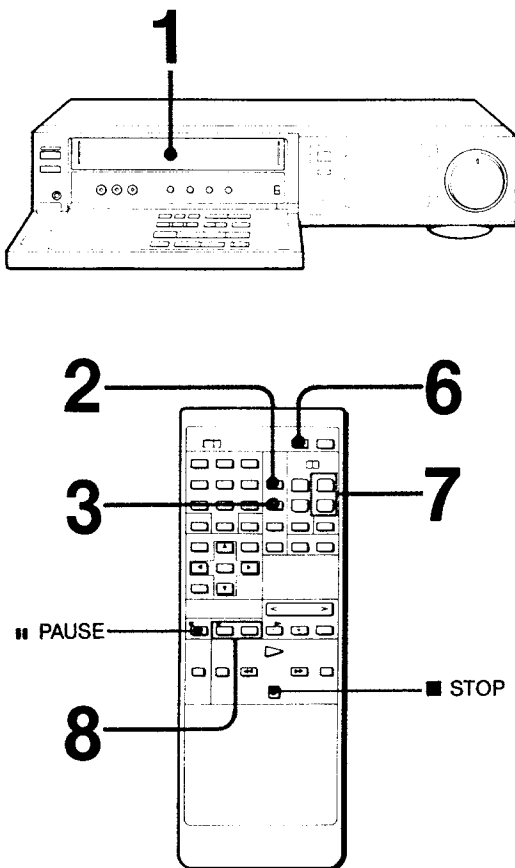

To stop recording, press ■ STOP.

To stop the tape for a moment, press || PAUSE.

To resume recording, press || PAUSE again.

During recording, if the pause mode lasts for more than approximately 5 minutes, the VCR enters the stop mode automatically.

When the tape reaches its end

The tape is automatically rewound to the beginning and the power remains on.

- 1** Insert a cassette.
The VCR is turned on automatically (Auto power on).
- 2** Press **INPUT SELECT** to display the TUNER indicator in the display window.
- 3** Select the recording tape speed, SP or EP, with **REC MODE**.
- 4** Turn on the TV.
- 5** If your TV is equipped with video/audio input jacks
Select the input for the VCR.
If your TV is not equipped with video/audio input jacks
Select the channel for the VCR (3 or 4.)
- 6** Press **ANT TV/VTR** so that the VTR indicator lights.
(Necessary only when the VCR and the TV are connected via the VHF antenna terminal.)
- 7** Select the channel to be recorded with **CHANNEL +/-** or **channel number button(s)** and **ENTER**.
- 8** Press the two ● **REC** buttons simultaneously.
(On the VCR press ● **REC**.)
The REC indicator lights and recording begins.

What does the VTR indicator appearing in the display window indicate?

VTR indicator	What is shown
Lit	TV program selected by the VCR or playback picture
Unlit	TV program selected by a TV

Recording TV Programs

To Stop Recording Momentarily at an Unwanted Scene

You can stop recording when an unwanted scene appears and then resume recording smoothly from a desired scene.

- 1 Press **|| PAUSE** when an unwanted scene appears. The VCR enters recording pause mode.
- 2 Press **|| PAUSE** again at the point where you want to continue recording.

To Cut Out an Unwanted Scene by Recording Over It

If you have started recording unwanted scene, you can return the tape to the start of that scene and make the VCR enter recording pause mode.

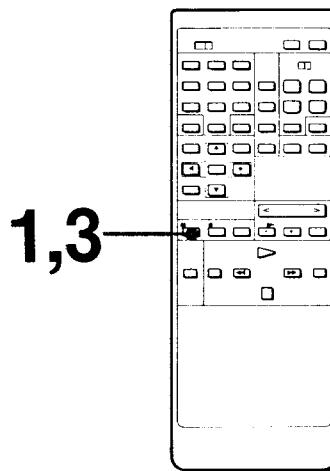
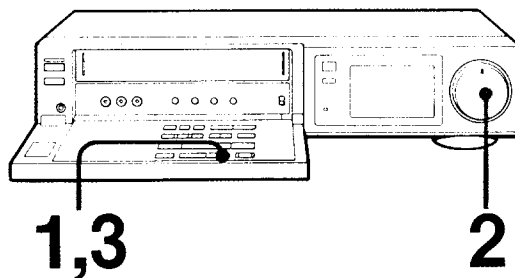

- 1 Press **|| PAUSE** to set the VCR to the recording pause mode at an unwanted scene.

- 2 **Rewind the tape to the desired point with SWING SHUTTLE.**

When you release **SWING SHUTTLE**, the VCR resumes the recording pause mode.

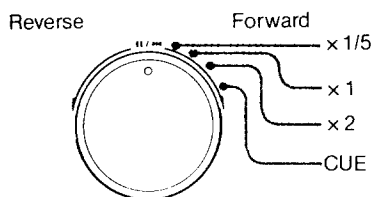

The playback picture appears on the screen during rewinding/advancing the tape. The sound being broadcast will be heard.

- 3 Press **|| PAUSE** at the desired scene. Recording starts again.

How to use SWING SHUTTLE during playback or in the playback pause mode

Use this function when the new picture should be recorded over the unwanted scene of the recorded tape.

- 1 Rewind the tape to the desired scene with **SWING SHUTTLE**. (When you release it, the VCR enters the playback pause mode.)
- 2 Press **● REC** to set the VCR to the recording pause mode.
- 3 To start recording, press **|| PAUSE** at the desired scene.

To Record a Program without Watching the TV

Turn off the power of the TV or color monitor. Recording continues.

Watching One TV Program While Recording Another

When the TV is connected only to VHF/UHF OUT

- 1 Press **ANT TV/VTR** so that the VTR indicator goes off.
- 2 Select the channel you want to watch on the TV.

When the TV is connected to MONITOR OUT

Select the tuner input and choose the channel you want to watch on the TV.

Note

If you use a color monitor, you cannot view another program during recording unless the monitor has an internal TV tuner.

Recording TV Programs

Recording Multichannel TV Sound (MTS) Broadcasts

To record a stereo broadcast

When a stereo broadcast program is received, the STEREO indicator appears in the display window. The stereo program is automatically recorded in stereo. If a stereo program is noisy, set AUTO STEREO to OFF in the MODE SET menu. The sound is heard in monaural but the noise is reduced.

Use ▲ and ▼ to move cursor.
Use ► and ◀ to move dot.

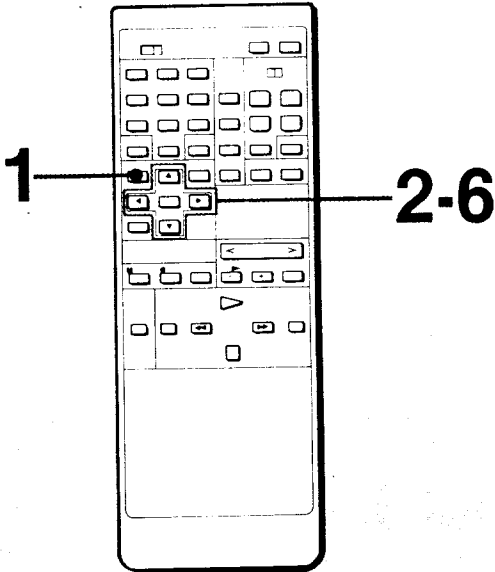

1 Press **MENU**.
The main MENU appears.

2 Move cursor to
MODE SET.

```
MENU
AUTO MENU
AUTO REPEAT
TIMER SET/CHECK
▶MODE SET
TUNER PRESET
FUNCTION MEMORY
CLOCK SET
DEMONSTRATION
```

3 Press **EXECUTE**.
If the MODE SET [PAGE 2] menu appears, move cursor to PREVIOUS PAGE and press **EXECUTE**. The MODE SET [PAGE 1] menu is displayed.

```
MODE SET [PAGE 1]
▶AUTO ANT SEL •ON OFF
AUTO STEREO •ON OFF
CLOCK DISPLAY•ON OFF
DIMMER ON •OFF
NORMAL AUDIO•MAIN SAP
BACK COLOR •BL GR P K
NEXT PAGE
```

4 Move cursor to AUTO STEREO.

5 Move dot to OFF.

```
MODE SET [PAGE 1]
AUTO ANT SEL •ON OFF
▶AUTO STEREO ON •OFF
CLOCK DISPLAY•ON OFF
DIMMER ON •OFF
NORMAL AUDIO•MAIN SAP
BACK COLOR •BL GR P K
NEXT PAGE
```

6 Press **EXECUTE** to return to the original screen.

To record SAP (Second Audio Program) broadcast
 Normally, set NORMAL AUDIO to MAIN in the MODE SET menu. The main sound is recorded on the normal track.
 To record the SAP sound on the normal audio track, set NORMAL AUDIO to SAP in the MODE SET menu.

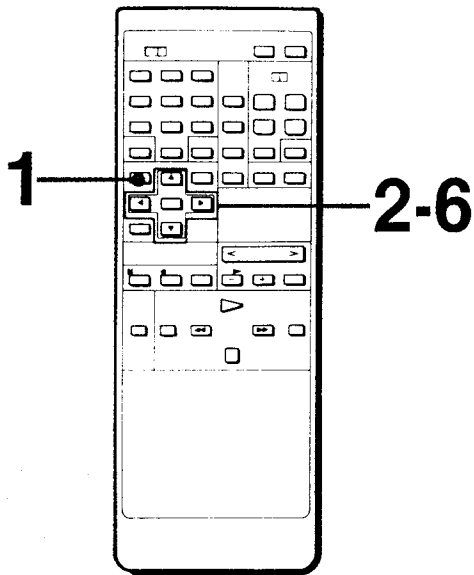

Notes

- When there is no SAP broadcast, select MAIN in step 5. If the SAP is selected, no sound will be recorded on the normal audio track.
- When the VCR and the TV are connected via the VHF antenna terminal, you cannot hear a program in stereo.

1 Press **MENU**.

2 Move cursor to **MODE SET**.

3 Press **EXECUTE**.
 If the **MODE SET [PAGE 2]** menu appears, move cursor to **PREVIOUS PAGE** and press **EXECUTE**.
 The **MODE SET [PAGE 1]** menu is displayed.

```

MODE SET [PAGE 1]
▶AUTO ANT SEL  •ON OFF
AUTO STEREO   •ON OFF
CLOCK DISPLAY •ON OFF
DIMMER        ON  OFF
NORMAL AUDIO •MAIN SAP
BACK COLOR   •BL GR PK
NEXT PAGE
  
```

4 Move cursor to **NORMAL AUDIO**.

5 Move dot to **SAP**.

```

MODE SET [PAGE 1]
AUTO ANT SEL  •ON OFF
AUTO STEREO   •ON OFF
CLOCK DISPLAY •ON OFF
DIMMER        ON  OFF
▶NORMAL AUDIO •MAIN•SAP
BACK COLOR   •BL GR PK
NEXT PAGE
  
```

6 Press **EXECUTE** to return to the original screen.

To monitor the SAP sound being recorded
 Press **AUDIO MONITOR** to light the SAP indicator in the display window.

Use of the Tape Counter

Indexing the Tape Contents

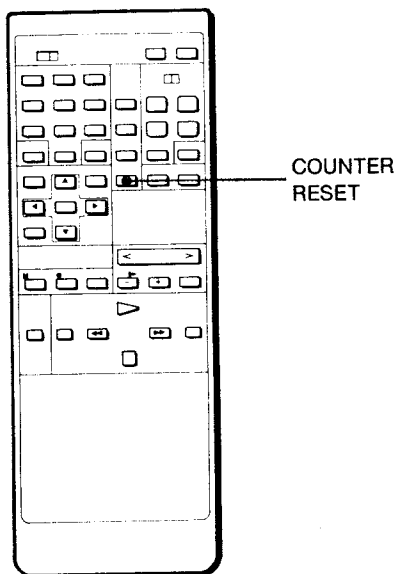

Before starting recording or playback, press **COUNTER RESET** to set the counter to zero. By noting the counter reading at the desired point, you can easily find that point later by referring to the counter. Use the label on the cassette to list the programs and their counter readings.

Note on counter reading

Even after the cassette is ejected, the counter reading is retained until a cassette is inserted again. The counter then returns to "0H00M00S".

Display window

0 H 00 M 00 S

Tape Return/Tape Return Play

Tape return

— To search and stop the tape at the counter zero point.

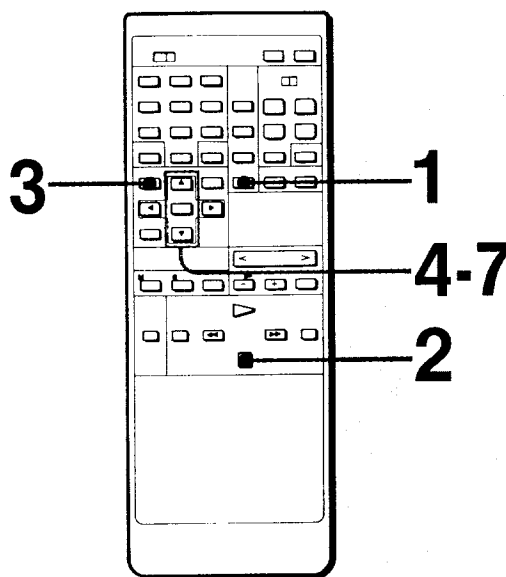

1 During recording or playback, press the **COUNTER RESET** at the point you want to locate later. The tape counter changes to "0H00M00S".

2 When recording or playback is completed, press **STOP**.

3 Press **MENU**. The main MENU appears.

4 Move cursor to AUTO MENU.

```
MENU
▶AUTO MENU
  AUTO REPEAT
  TIMER SET/CHECK
  MODE SET
  TUNER PRESET
  FUNCTION MEMORY
  CLOCK SET
  DEMONSTRATION
```

5 Press **EXECUTE**. The AUTO MENU appears.

6 Move cursor to GO TO ZERO - STOP.

```
AUTO MENU
  PLAY-REW-POWER OFF
  ▶GO TO ZERO-STOP
  GO TO ZERO-PLAY
  GO TO REC START PLAY
  REW-POWER OFF
  REW-EJECT-POWER OFF
  REW-PLAY
  REW-TIMER REC
```

7 Press **EXECUTE**. The tape is rewound or advanced close to the counter zero point, and stop at the counter zero point.

Tape return play

— To search and playback from the counter zero point

1 Follow steps 1 to 5 in "Tape return" operation.

2 Move cursor to GO TO ZERO - PLAY.

```
AUTO MENU
  PLAY-REW-POWER OFF
  GO TO ZERO-STOP
  ▶GO TO ZERO-PLAY
  GO TO REC START PLAY
  REW-POWER OFF
  REW-EJECT-POWER OFF
  REW-PLAY
  REW-TIMER REC
```

3 Press **EXECUTE**. The tape is rewound or advanced close to the counter zero point and starts playback.

Notes

- The tape counter does not work on the portions of the tape with no signals recorded.
- The counter zero point may be few seconds ahead or behind the exact time.

Timer Recording

You can preset up to eight recordings as much as one month* in advance.*
 The recordings can be preset on the TV screen with the Remote Commander.

* Recording from today to one month later

If today is August 31st, you can set the timer to record a program broadcast between today and September 30 (for 31 days).

If today is January 31st, you can set the timer to record a program broadcast between today and February 28 (for 29 days). A Leap year is automatically calculated.

Before You Begin

- The date and clock must be set correctly. (See "Date and Clock Setting.") (page 24)
- Make sure the cassette tape is long enough to record all the programs.
- Be sure that the safety tab on the cassette has not been broken off. If you insert a cassette without its safety tab and press **TIMER REC ON/OFF**, the cassette will be automatically ejected.
- Set **REC LEVEL** to the **5** position.
- Turn on the VCR and the TV.

Timer Setting Example

Example: To record channel 26 from 9:00 PM to 10:55 PM on Wednesday, May 16 in EP mode.

Use **▶** and **◀** to select items.
 Use **▲** and **▼** to change numbers or to move cursor.

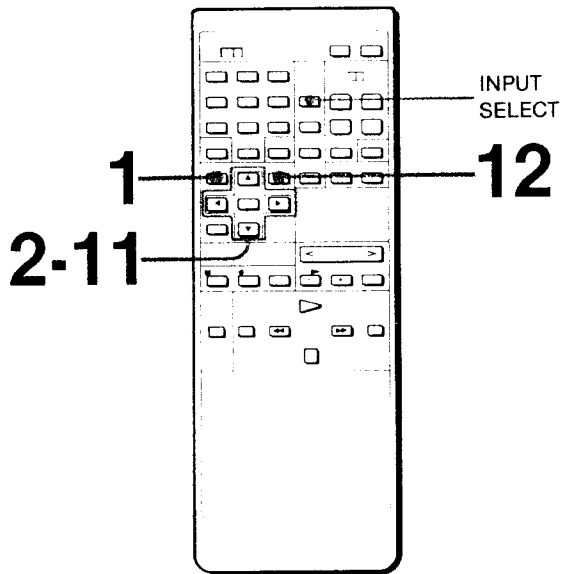

1 Press **MENU**.
 The main MENU appears.

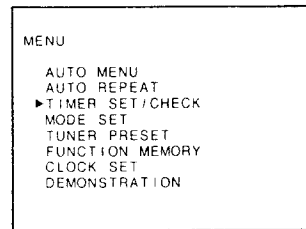

2 Move cursor to **TIMER SET/CHECK**.

3 Press **EXECUTE**.
 The **TIMER SET/CHECK** display appears.

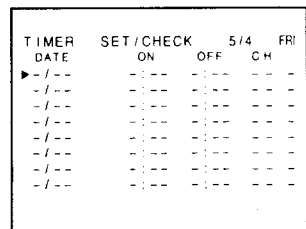

4 Press **▶** to set the date.
 Today's date is blinking.
 If not, set the correct date. (See "Date and Time Setting.")

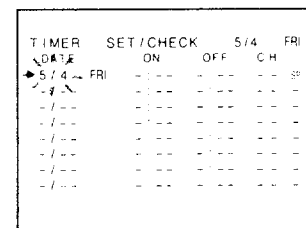

5 Press ▲ until 5/16 WED appears.

6 Press ► to set the turn-on hour. The current hour blinks. Press ▲ or ▼ to make PM 9: appear.

TIMER	SET /CHECK	5/4	FRI
DATE	ON	OFF	CH
►5/16	WED PM 9	---	SP
/--	---	---	---
/--	---	---	---
/--	---	---	---
/--	---	---	---
/--	---	---	---
/--	---	---	---

7 Press ► to set the turn-on minute. The current minute blinks. Press ▲ or ▼ to make 00 appear.

TIMER	SET /CHECK	5/4	FRI
DATE	ON	OFF	CH
►5/16	WED PM 9:00	---	SP
/--	---	---	---
/--	---	---	---
/--	---	---	---
/--	---	---	---
/--	---	---	---
/--	---	---	---

8 Press ► to set the turn-off time. The on-time blinks in the off-time position. Set the turn-off time referring to steps 6 and 7.

TIMER	SET /CHECK	5/4	FRI
DATE	ON	OFF	CH
►5/16	WED PM 9:00 PM 10:55	---	SP
/--	---	---	---
/--	---	---	---
/--	---	---	---
/--	---	---	---
/--	---	---	---
/--	---	---	---

9 Press ► to set the channel. Press ▲ until 26 appears. Only the channels preset in the VCR appear. You can enter them with the **channel number button(s)** and **ENTER**.

TIMER	SET /CHECK	5/4	FRI
DATE	ON	OFF	CH
►5/16	WED PM 9:00 PM 10:55	---	26 SP
/--	---	---	---
/--	---	---	---
/--	---	---	---
/--	---	---	---
/--	---	---	---
/--	---	---	---

10 Press ► to set the recording tape speed. Press ▲ or ▼ until EP appears. You can set it with **REC MODE**.

TIMER	SET /CHECK	5/4	FRI
DATE	ON	OFF	CH
►5/16	WED PM 9:00 PM 10:55	---	26 EP
/--	---	---	---
/--	---	---	---
/--	---	---	---
/--	---	---	---
/--	---	---	---
/--	---	---	---

11 Press ► to finish presetting. To preset other programs, press ▼ to move cursor to the next line and repeat steps 4 to 11.

TIMER	SET /CHECK	5/4	FRI
DATE	ON	OFF	CH
►5/16	WED PM 9:00 PM 10:55	---	26 EP
/--	---	---	---
/--	---	---	---
/--	---	---	---
/--	---	---	---
/--	---	---	---
/--	---	---	---

12 Press **EXECUTE**. Press **TIMER REC ON/OFF** to set the VCR in the timer recording standby mode. The VCR is turned off.

To record from equipment connected to the LINE IN 1 or 2 jacks

Press **INPUT SELECT** anytime in step 4 to 10 to display LINE 1 or LINE 2 on the CH position.

To change the item before completing the setting

Press ◀ or ▶ to make the item to be changed blink and change it with ▲ or ▼.

Every Week Recording and Every Day Recording

You can preset to record the same program every day or the same program on a specific day of every week.

Press **▲** repeatedly until the desired indicator appears in step 5 in the "Operation". The indicator changes as follows.

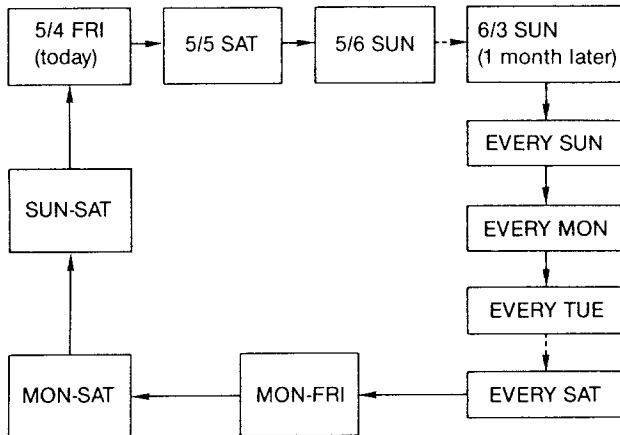

Press **▼** for the reverse direction.

EVERY SUN - - - EVERY SAT

At the same time on the same day every week

MON - FRI

At the same time every day from Monday to Friday

MON - SAT

At the same time every day from Monday to Saturday

SUN - SAT

At the same time every day

To Rewind the Tape Automatically to the Recording Start Point After Timer Recording Is Over

- 1 Press **MENU**.
The main MENU appears.
- 2 Move cursor to MODE SET.
- 3 Press **EXECUTE**.
If the MODE SET [PAGE 1] menu appears, move cursor to NEXT PAGE and press **EXECUTE**.
The MODE SET [PAGE 2] menu is displayed.
- 4 Move cursor to TIMER REC - REW.
- 5 Move dot to ON.
- 6 Press **EXECUTE** to return to the original screen.

Notes

- If other timer recordings have been preset, TIMER REC - REW does not function after one timer recording is over.
- If the tape comes to its end during timer recording, the tape will be rewound to the recording start point and the power will be turned off.

To Check the Timer Settings

Check the timer settings by displaying a program list on the TV screen.

Use ▲ and ▼ to move cursor.

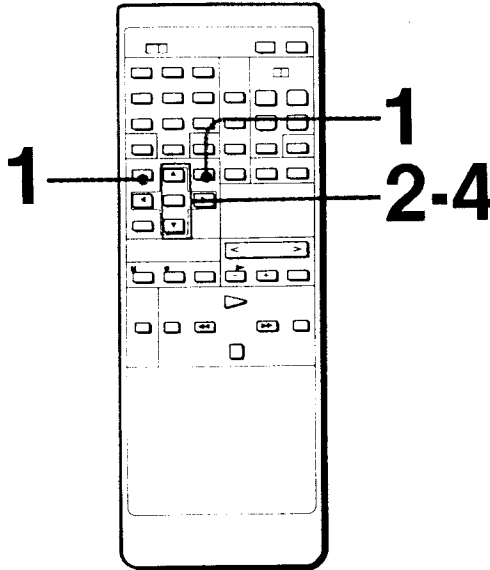

- 1 Press **TIMER REC ON/OFF** to turn off the **TIMER REC** indicator and turn on the **VCR**. Press **MENU**. The main **MENU** appears.

- 2 Move cursor to **TIMER SET/CHECK**.

```

MENU
AUTO MENU
AUTO REPEAT
▶TIMER SET/CHECK
MODE SET
TUNER PRESET
FUNCTION MEMORY
CLOCK SET
DEMONSTRATION
    
```

- 3 Press **EXECUTE**. The **TIMER SET/CHECK** display (program list) appears.

```

TIMER SET/CHECK 5/4 FRI
DATE ON OFF CH
▶5/4 FRI AM 7:00AM 8:00 12 SP
5/15 TUE PM 12:00PM 2:15 LINE2 EP
6/3 SUN PM 1:00PM 2:00 LINE1 SP
MON - FRI PM 11:00PM 1:15 6 EP
MON - SAT AM 8:15AM 8:30 15 SP
SUN - SAT PM 9:00PM 11:10 10 EP
EVERY SAT PM 8:00PM 8:54 8 EP
5/27 SUN AM 10:00AM 12:00 50 SP
    
```

- 4 To erase the list, press **EXECUTE**.

To return to timer recording standby mode
Press **TIMER REC ON/OFF**.

When the Presettings of Timer Recordings Overlap

- If the turn-on times of two programs are the same
The recording listed upper on the **TIMER SET/CHECK** display will be made. The memory of the program listed lower will be cleared (if it is for one-day program).

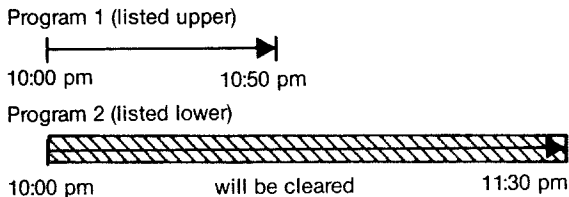

- If the recording start time of program 2 is the same as the recording end time of program 1
The last 20 seconds of program 1 will not be recorded.

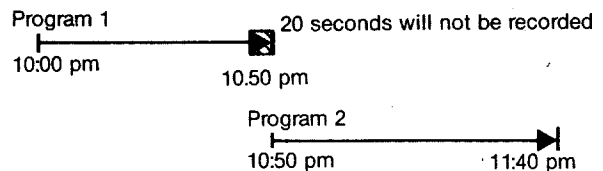

- If the recording start time of program 2 comes before the recording of program 1 is finished
The recording of program 2 begins before program 1 is finished.

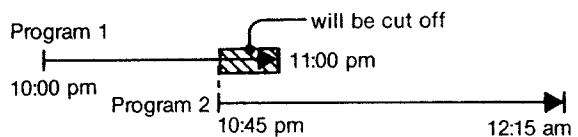

Timer Recording

Problems When TIMER REC ON/OFF is Pressed

The cassette is ejected automatically.	The safety tab of the inserted cassette has been broken off.
The TIMER indicator does not appear.	<ul style="list-style-type: none">•No cassette has been inserted.•The tape is at its end.•No program is set.

Information about timer recording

- When the recording is completed, the memory of the program is erased if it is for only one day.
- If the tape reaches at its end before the turn-off time, recording will stop and the power will turn off.

If a power interruption occurs

- If a power interruption lasting less than approximately 3 hours occurs while the VCR is waiting for a preset time, the VCR will enter the standby mode for timer recording again. (If a power interruption lasting more than approximately 3 hours occurs before a timer recording the memory will be cleared. Reset the date and time, then preset the date for the timer recording again.)
- If a power interruption lasting less than approximately 3 hours occurs during a timer recording, the VCR will start recording again but the tape counter will indicate "0H00M00S."

To Cancel or Change the Timer Settings

You can cancel or change the timer settings by displaying the program list on the TV screen.

Use ▲ and ▼ to move cursor.
Use ► and ◀ to blink items.

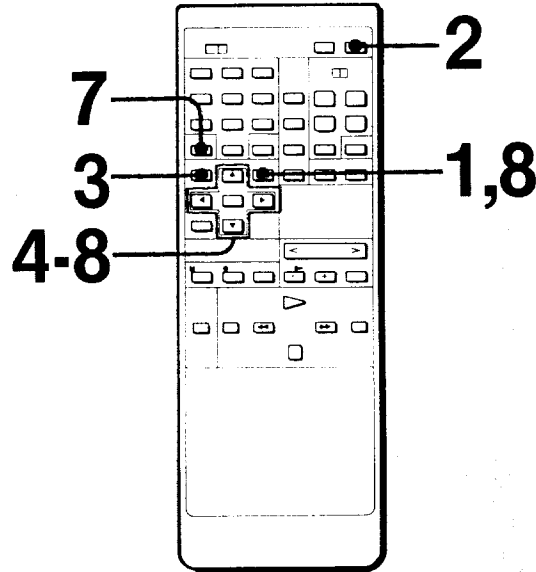

1 If **TIMER REC** indicator is turned on, press **TIMER REC ON/OFF** so that the **TIMER REC** indicator disappears.

2 If the power is turned off, press **POWER** to turn the power on.

3 Press **MENU**.
The main **MENU** appears.

4 Move cursor to **TIMER SET/CHECK**.

```

MENU
AUTO MENU
AUTO REPEAT
▶TIMER SET/CHECK
MODE SET
TUNER PRESET
FUNCTION MEMORY
CLOCK SET
DEMONSTRATION
  
```

5 Press **EXECUTE**.
The **TIMER SET/CHECK** display appears.

```

TIMER SET/CHECK 5/4 FRI
DATE ON OFF CH
▶5/4 FRI AM 7:00AM 8:00 12 SP
5/15 TUE PM12:00PM 2:15LINE2 EP
6/3 SUN PM 1:00PM 2:00LINE1 SP
MON-FRI PM11:00PM11:15 6 EP
MON-SAT AM 8:15AM 8:30 15 SP
SUN-SAT PM 9:00PM11:10 10 EP
EVERY SAT PM 8:00PM 8:54 8 EP
5/27 SUN AM10:00AM12:00 50 SP
  
```

6 Move cursor to the program to be canceled or changed.

7 To cancel it, press **TIMER CLEAR**.

```

TIMER SET/CHECK 5/4 FRI
DATE ON OFF CH
5/4 FRI AM 7:00AM 8:00 12 SP
5/15 TUE PM12:00PM 2:15LINE2 EP
▶5/4 FRI AM 7:00AM 8:00 12 SP
MON-FRI PM11:00PM11:15 6 EP
MON-SAT AM 8:15AM 8:30 15 SP
MON-SAT PM 9:00PM11:10 10 EP
EVERY SAT PM 8:00PM 8:54 8 EP
5/27 SUN AM10:00AM12:00 50 SP
  
```

To change it, move the blinking position to the item to be changed and re-enter the item.

```

TIMER SET/CHECK 5/4 FRI
DATE ON OFF CH
5/4 FRI AM 7:00AM 8:00 12 SP
5/15 TUE PM12:00PM 2:15LINE2 EP
▶5/20 SUN PM 1:30PM 3:00LINE1 EP
MON-FRI PM11:00PM11:15 6 EP
MON-SAT AM 8:15AM 8:30 15 SP
SUN-SAT PM 9:00PM11:10 10 EP
EVERY SAT PM 8:00PM 8:54 8 EP
5/27 SUN AM10:00AM12:00 50 SP
  
```

8 Press **EXECUTE** to return to the original screen.
Press **TIMER REC ON/OFF** to return to timer recording standby mode.

To Use the VCR during Timer Recording Standby Mode

If you want to use the VCR when it is in the timer recording standby mode, you must cancel the standby mode.

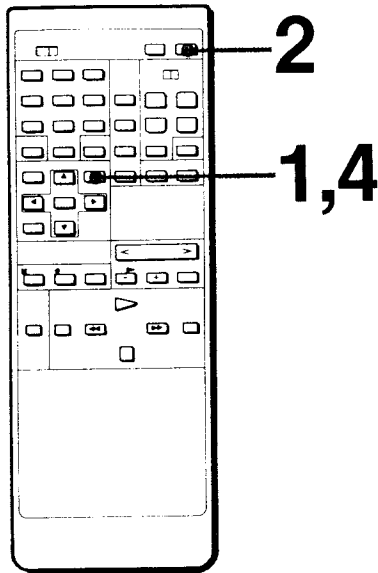

1 Press **TIMER REC ON/OFF** so that the **TIMER REC** indicator in the display window disappears.

2 Turn on the power of the VCR.

3 Operate the VCR.

4 After using the VCR, press **TIMER REC ON/OFF** so that the **TIMER REC** indicator appears.

To stop a timer recording after recording has started
Press **TIMER REC ON/OFF**.

You can use the following buttons during timer recording. Others are not operable.

- **TIMER REC ON/OFF**
- **COUNTER RESET**
- **ANT TV/VTR** (to watch the picture broadcast on another channel)
- **DATA SCREEN**
- **TIMER SET/CHECK** (During recording, checking other settings is possible. But changing or canceling the settings is not possible.)

Recording a Timer Title

A timer title which consists of the items below is recorded on the tape for approximately 3 seconds before each recording.

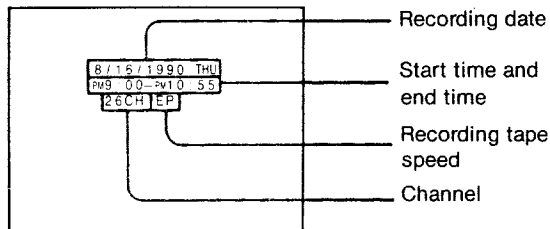

This function makes it easier to search for a certain program when several programs have been recorded on a single tape.

3 seconds

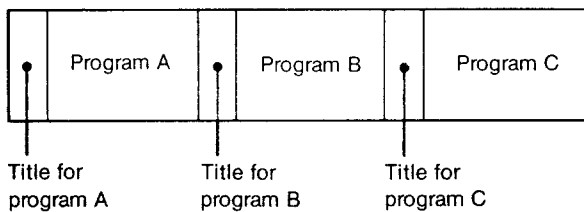

If you do not want a title to be recorded

Use ▲ and ▼ to move cursor.
Use ► and ◀ to move dot.

- 1 Press **MENU**.
The main MENU appears.
- 2 Move cursor to MODE SET.
- 3 Press **EXECUTE**.
If the MODE SET [PAGE 1] menu appears, move cursor to NEXT PAGE and press **EXECUTE**.
The MODE SET [PAGE 2] menu is displayed.
- 4 Move cursor to TIMER TITLE.
- 5 Move dot to OFF.

```

MODE SET [PAGE 2]
▶TIMER TITLE      ON •OFF
TIMER REC-REW    ON •OFF
AUDIO MIX        ON •OFF
PREVIOUS PAGE
    
```

- 6 Press **EXECUTE** to return to the original screen.

Quick Timer Recording

This function is convenient, for example, when you want to begin recording a program immediately, and do something else.

The timer can be set to operate within 8 hours in units of 30 minutes.

Before You Begin

- Set INPUT SELECT to TUNER (i.e. TUNER indicator appears.)
- Set the tape speed to SP or EP with **REC MODE**.
- REC LEVEL** must be set to the **5** position.
- The **TIMER REC** indicator must not be displayed. Press **TIMER REC ON/OFF** if the indicator is lit.

Operation

If you are recording now, perform only step 3.

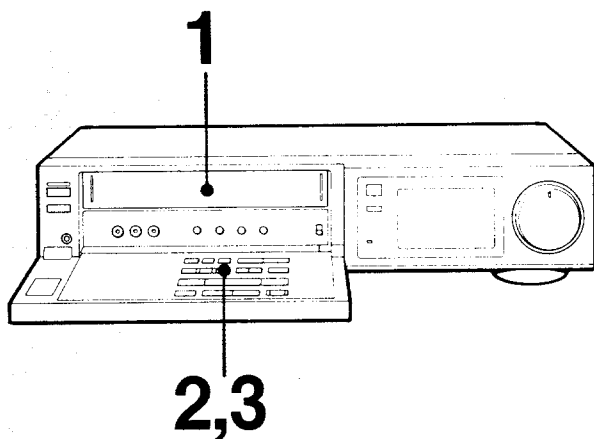

1 Insert a cassette.

2 Press **QUICK TIMER**.
The **TIMER** indicator lights.
While the channel display is blinking in the display window, select the desired channel with **CHANNEL + / -** or the **channel number button(s)** and **ENTER**.

3 Press **QUICK TIMER** again so that recording starts.
Now decide the recording duration.
Every time you press **QUICK TIMER**, the recording duration displayed increases by 30 minutes.

You can leave the VCR after turning off the TV.
The power of the VCR will be turned off automatically when preset duration comes.

Recording Duration Indication

Every time you press **QUICK TIMER**, the recording duration indication in the display window changes as shown below.

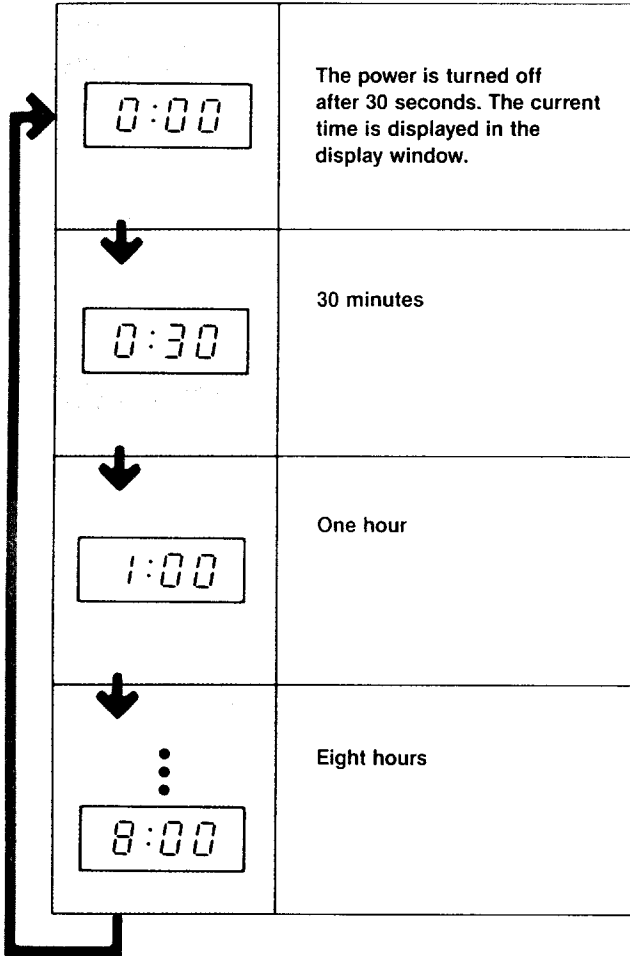

You can change the recording duration with **QUICK TIMER** even during quick timer recording. During recording, the displayed recording duration decreases minute by minute.

Buttons Operable During Quick Timer Recording

TIMER REC ON/OFF	To stop quick timer recording
QUICK TIMER	To change the recording duration
COUNTER RESET	To reset the tape counter to zero
ANT TV/VTR	To watch the picture broadcast on another channel
MENU	Only to check the timer recording settings

If the tape runs out during quick timer recording

Recording stops and the power is turned off. The tape is not rewound automatically.

If a cassette without its safety tab is inserted

The cassette is ejected automatically when you press **QUICK TIMER**.

If a power interruption occurs during quick timer recording

Recording stops and the power of the VCR turns off. If the power interruption lasts less than three hours and the power is restored within the quick timer duration, recording starts again.

Index Function

The desired program on the recorded tape can be easily located by detecting an index signal.

The index signals must be marked at the beginning of the program on the tape.

To Mark Index Signals

At the beginning of a recording, timer recording, or quick timer recording

An index signal is automatically marked on the tape.

To mark an index signal manually

Index signals can be marked at the desired scene during recording or normal playback.

Press **INDEX MARK** to mark an index signal. The **INDEX** indicator blinks in the display window and the **INDEX MARK** indicator appears on the screen while an index signal is being marked.

Notes

- Mark an index signal more than 2 minutes before or after the previous index signal so that the VCR can detect it correctly.
- While an index signal is being marked during playback, the recorded sound is not heard, but it will not be erased.
- You cannot mark an index signal in the following cases:
 - On a tape without its safety tab
 - On an unrecorded portion of a tape
 - Immediately before a point on the tape where the tape speed (EP or SP) changes
 - When playing back a tape recorded in the LP mode

Index Scan

You can play back the beginning of each program in sequence using the index function.

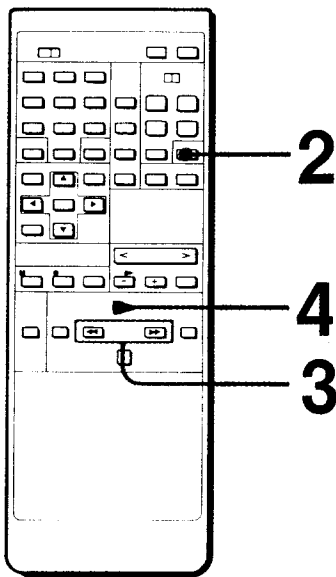

1 Insert a cassette with index signals marked.

2 Press **INDEX** once.

Display window



TV screen

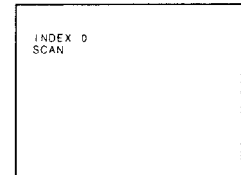

INDEX and SCAN
blink alternately.

3 To scan the previous programs, press **◀◀ REW.**
To scan the programs ahead, press **▶▶ FF.**
The **INDEX SCAN** indicator blinks continuously while scanning.
The tape is rewound or rapidly advanced to the next marked index signal, the tape is played back for approximately 10 seconds, and then rewound or advanced to the next index signal.
The displayed index number increases one by one (up to 19).

4 Press **▶ PLAY** when the desired program appears.
Normal playback of that program begins.

Index Search

You can locate the desired program and play it back automatically. You have to designate the number how many index signals ahead or behind the desired program is from the present one.

Up to 19 index signals from the present position on the tape can be located.

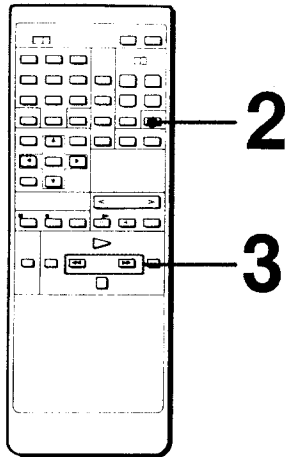

1 Insert a cassette with index signals marked.

2 Press **INDEX** until the index number of the desired program is displayed. The **INDEX** indicator and the **INDEX SEARCH** number light up.

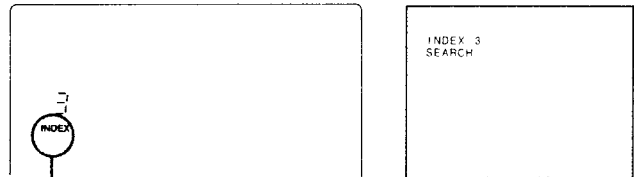

INDEX lights.

3 To locate a previous program on the tape, press **REW**.
To locate a program ahead, press **FF**.
The tape is rewound or rapidly advanced. Every time an index signal is detected, the **INDEX SEARCH** number decreases. When the number reaches 0, playback of the desired program begins.

How to designate the index number of the desired program

Beginning of the program

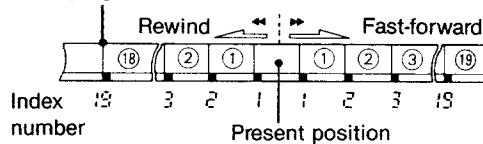

To Erase Index Signals

You can erase unnecessary index signals.

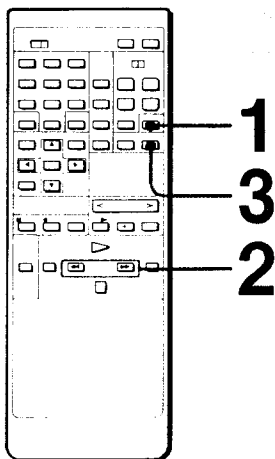

1 Press **INDEX** once.

2 Press **REW** or **FF**.
The tape is rewound or rapidly advanced. Every time an index signal is detected, the tape is played back and then rewound or advanced to the next index signal.

3 Press **ERASE** within approximately 10 seconds after you have verified the playback picture.

Notes

- While the index signal is being erased, the recorded sound is not heard but will not be erased.
- Index signals cannot be erased when they are marked just before and after the tape speed is changed or are marked on a LP mode tape.

Audio Recording

Hi-fi Recording

In conventional recording, audio signals are recorded on the audio track and video signals on the video track. In hi-fi recording, audio signals are recorded in the same manner as video signals, using two rotary hi-fi audio heads. Thus, high-quality sound recording is possible.

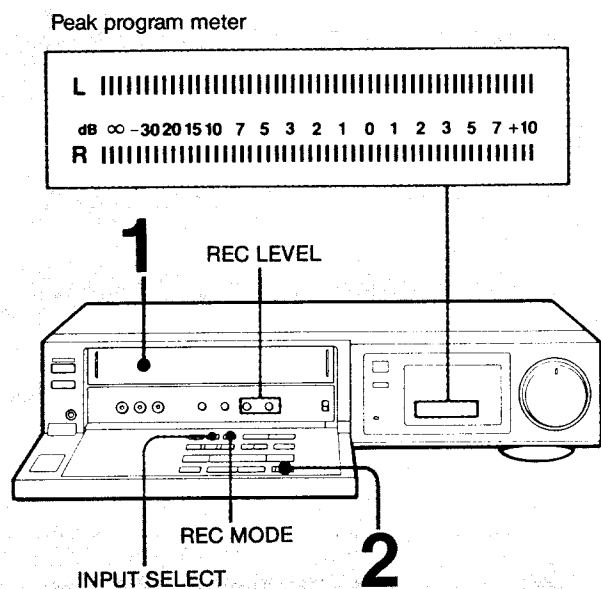

Before you begin

- Your audio system must be correctly connected to the VCR. (See "Connections.") (page 18)
- Set **INPUT SELECT** to LINE 1 or LINE 2 according to which your audio system is connected.
- Set **REC MODE** to SP or EP.
- Adjust **REC LEVEL**.
Play a recording source and manually adjust **REC LEVEL** while observing the PEAK PROGRAM METER.

When recording from a disk or FM tuner:

Adjust so that the right-most element sometimes lights up.

When recording from a compact disc or PCM digital audio processor:

Adjust so that the right-most element lights up only at the highest signal level.

Note

The elements which light up may be slightly different between L and R indicators.

Operation

1 Insert a cassette.

2 Press **• REC** on the VCR or two **• REC** buttons on the Commander simultaneously.

Hi-fi recording pattern on a tape

The VCR automatically performs hi-fi recording and normal audio recording at the same time, so that these tapes can also be played back on any VCR without a hi-fi system.

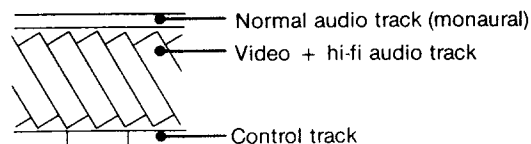

PCM Recording and Playback

You can enjoy PCM recording and playback by connecting a PCM digital audio processor to LINE IN and OUT VIDEO on this VCR.

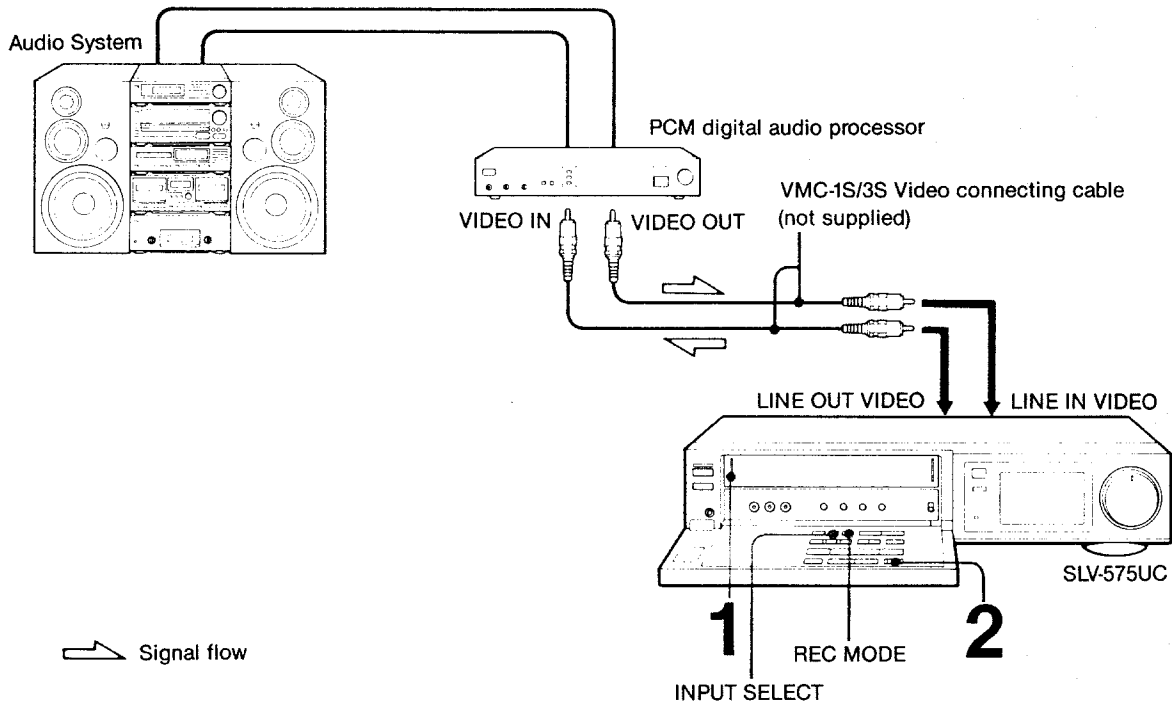

Before you begin

- Press **INPUT SELECT** to light **LINE 1** or **LINE 2** according to which the PCM digital audio processor is connected.
- Select the tape speed, **SP** or **EP** with **REC MODE**.

Operation

- 1** Insert a cassette.
- 2** Press **REC** on the VCR or two **REC** buttons on the Commander.

- For details, refer to the instruction manual of the digital audio processor and the audio system.

Editing with Another VCR

Using an additional VCR, you can create your own video program tape.

Before You Begin

When you use this VCR as the recording VCR

Check the followings on this VCR.

- Press **INPUT SELECT** to light LINE 1 or LINE 2 according to which the other VCR is connected.
- Select the recording tape speed, SP or EP.
- Set **REC LEVEL** to **5**.

When you use this VCR as the playback VCR

Select the sound to be recorded with **AUDIO MONITOR** on the Commander.

Use of the EDIT ON/OFF button

Before editing, press **EDIT ON/OFF** to light the EDIT indicator in the display window. This enables recording and playback of higher quality pictures during editing. If the other VCR is equipped with this function, activate it. However, even when using this function, the quality of the edited tape will have a certain extent of deterioration in picture and sound. Avoid using the edited tape for multiple generation of editing.

Caution

Television programs, films, video tapes and other materials may be copyrighted. Unauthorized duplication of such material may be contrary to the provisions of the copyright laws.

Editing a Home Movie Tape from Another VCR

Example: From an 8mm video camera recorder to this VCR

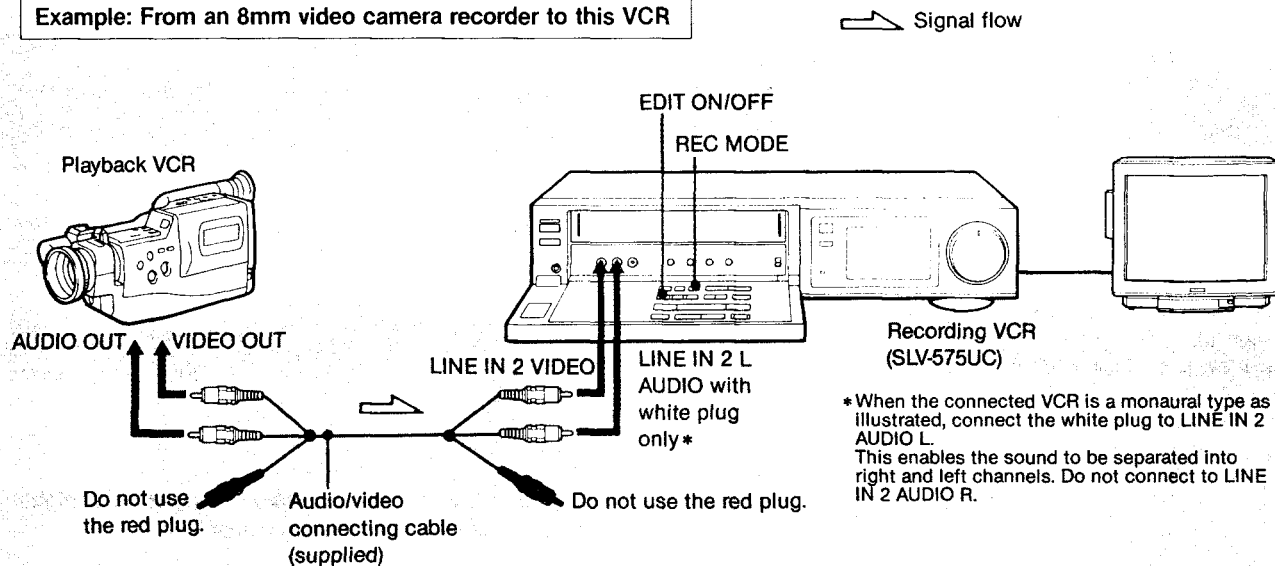

- 1 Turn on the power of the playback VCR and insert a source tape.
- 2 Insert a tape for recording into this VCR.
- 3 Press **EDIT ON/OFF** to light the indicator in the display window. Activate the EDIT mode if the playback VCR has this function.
- 4 Locate the playback start point on the playback VCR and set it to the playback pause mode.

- 5 Locate the recording start point on this VCR and set it to the recording pause mode.
- 6 Press the **PAUSE** button on both VCRs simultaneously. The other VCR starts playback and this VCR starts recording.

When editing is completed

Press the **STOP** button on both VCRs.

Editing a Home Movie Tape from This VCR

Example: From this VCR to a Sony Betamax VCR

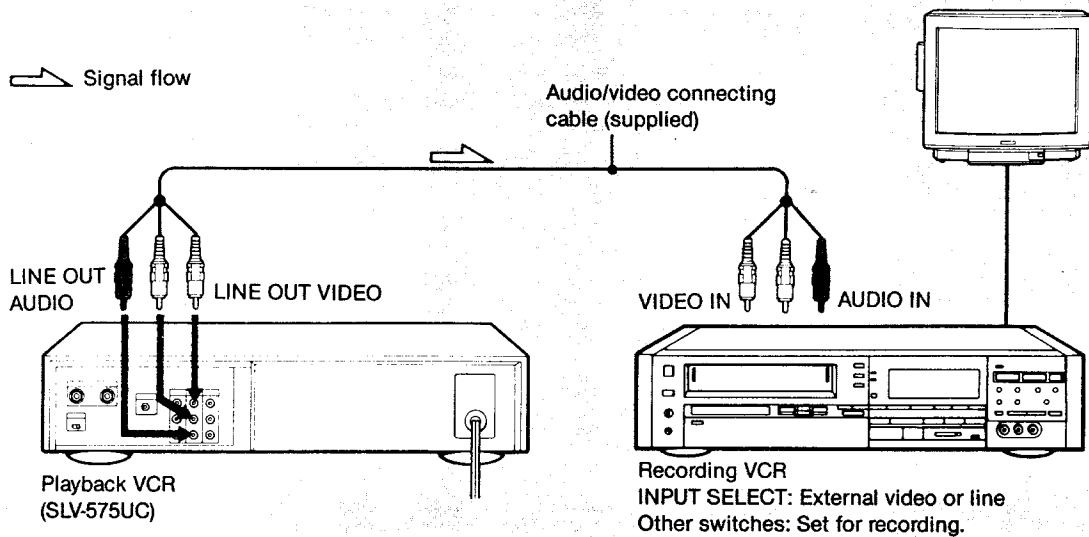

- 1 Insert a source tape into this VCR.
- 2 Turn on the power of the recording VCR and insert a tape for recording.
- 3 Press **EDIT ON/OFF** to light the EDIT indicator in the display window. Activate EDIT function if the recording VCR has this function.
- 4 Locate the playback start point on this VCR and set it to the playback pause mode.
- 5 Locate the recording start point on recording VCR and set it to the recording pause mode.
- 6 Press the **PAUSE** button on both VCRs simultaneously. This VCR starts playback and the other VCR starts recording.

When editing is completed

Press the **STOP** button on both VCRs.

If the connected VCR is a monaural type

- Use the VMC-910MS/920MS connecting cable instead of the supplied audio/video connecting cable.
- To play back a cassette tape on which an MTS broadcast has been recorded, select the monitor sound with **AUDIO MONITOR** on the Commander.

Note

Do not connect the same VCR to both the LINE IN and LINE OUT jacks of this VCR. This may cause a humming noise.

Editing with Another VCR

Editing a Home Movie Tape from Another VCR with a CONTROL S Out Jack

Example: From a Sony Betamax VCR to this VCR

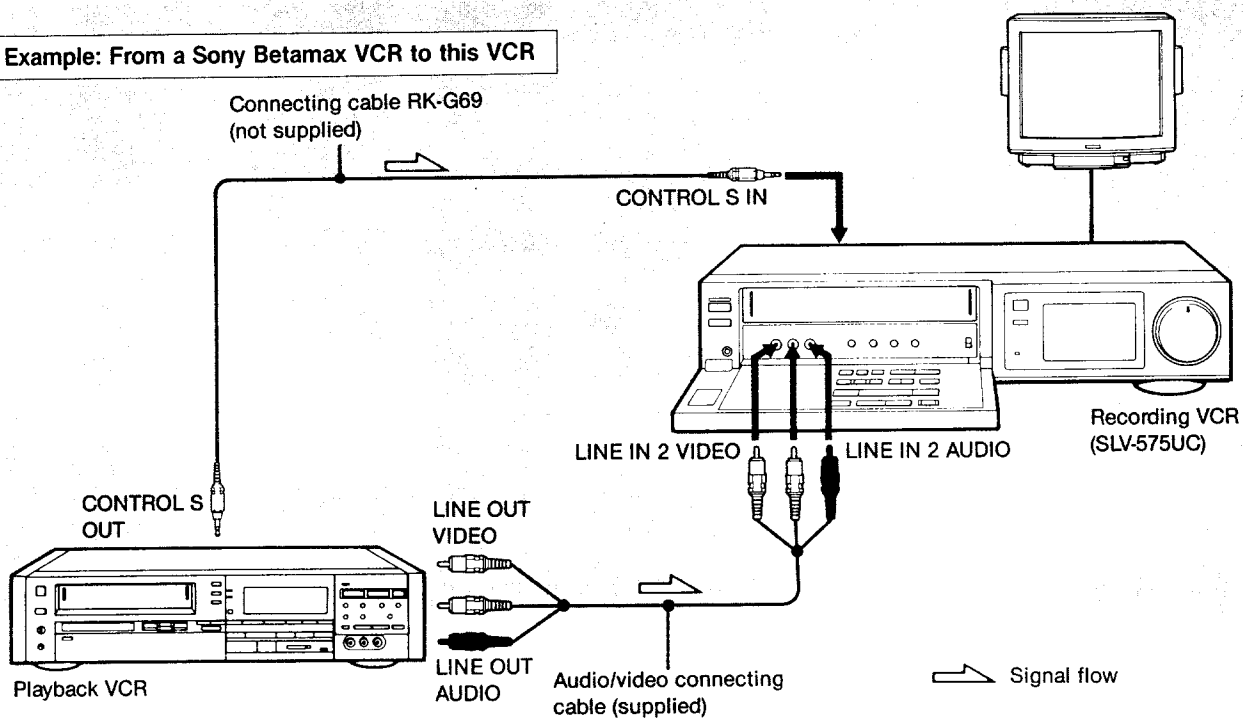

- 1 Turn on the power of the playback VCR and insert a source tape.
Activate the EDIT function if the VCR has it.
- 2 Insert a tape for recording into this VCR.
- 3 Locate the edit start point on this VCR and set it to the recording pause mode.
- 4 Locate the playback start point on the playback VCR and set it to the playback pause mode.
- 5 Press the SYNCHRO EDIT button on the playback VCR.
The other VCR starts playback and this VCR starts recording.
- 6 Press the SYNCHRO EDIT button on the playback VCR at the edit end point.
The playback VCR enters the playback pause mode and this VCR enters recording pause mode.

To edit the next scene

Repeat steps 4 to 6.

When editing is completed

Press the STOP button on both VCRs.

Setting of COMMAND MODE

Set COMMAND MODE on this VCR to VTR 1 or VTR 2. Otherwise, this VCR cannot be operated. When using the Remote Commander, set COMMAND MODE on the Commander to VTR 1 or VTR 2, also.

Indications in the Display Window

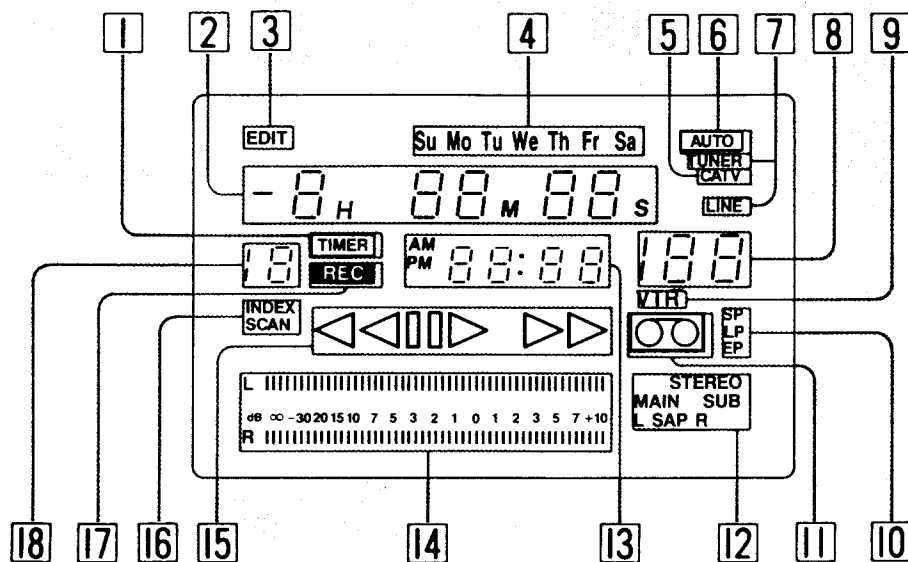

- | | |
|---|--|
| <p>1 TIMER recording indicator
Appears while the VCR is performing timer-recording, is waiting for the turn-on time of timer recording, or is performing quick timer recording.</p> <p>2 Linear time counter</p> <p>3 EDIT indicator</p> <p>4 Day of the week indicator</p> <p>5 CATV indicator</p> <p>6 Automatic function indicator</p> <p>7 Input mode indicators</p> <p>8 Channel number and input mode</p> | <p>9 VTR indicator</p> <p>10 Tape speed indicator (LP is for playback only)</p> <p>11 Cassette indicator</p> <p>12 Stereo program/SAP indicator</p> <p>13 Current time</p> <p>14 Peak program meter</p> <p>15 Tape transport indicator</p> <p>16 INDEX, INDEX SCAN indicator</p> <p>17 REC (recording) indicator
Appears while the VCR is performing normal recording, timer recording, is waiting for the turn-on time of timer recording, or is performing quick timer recording.</p> <p>18 INDEX number</p> |
|---|--|

Troubleshooting

If any difficulty should arise during operation, first check the power cord connection, then go through the following list. Should the difficulty persist, unplug the VCR, and contact your Sony dealer or local authorized Sony service facility.

	Symptom	Possible causes and remedies
Power	The POWER switch does not function.	<ul style="list-style-type: none"> •The power cord is disconnected. •The VCR is in the timer recording standby mode.
	The power is turned off.	The safety device on the VCR has been activated. Turn the power off, disconnect the power cord from the wall outlet and leave the VCR turned off for more than 1 minute.
Clock and timer	The clock has stopped and "AM 12:00" is blinking.	There has been a power interruption. Reset the date, clock time and timer settings.
TV reception	TV program is not clearly displayed on the TV screen.	<ul style="list-style-type: none"> •The channel for the VCR is not correctly tuned on the TV. •The TV signal is weak. Adjust the direction of the antenna. •The AC power cord of the VCR is disconnected.
Recording and playback	Noisy picture during recording	<ul style="list-style-type: none"> •The channel for the VCR is not correctly tuned on the TV. •The TV signal is weak. Adjust the direction of the antenna.
	No picture on the TV screen	<ul style="list-style-type: none"> •Press ANT TV/VTR so that the VTR indication appears in the display window. •The TV's channel is not set to 3 CH or 4 CH, or the video input has not been selected on the TV.
	Recording cannot be made.	<ul style="list-style-type: none"> •No cassette has been inserted. •The tape is at its end. •INPUT SELECT is not set correctly.
	The playback picture is not clear.	<ul style="list-style-type: none"> •The channel for the VCR is not correctly tuned on the TV. •A tape recorded on another VCR is being played back. Adjust the tracking with TRACKING NORMAL/SLOW and STILL ADJUST. •The video heads are dirty. Clean the heads using the Sony T-25CL video head cleaning cassette. For details on cleaning, refer to the instructions furnished with the cleaning cassette. If the cleaning cassette is not available in your area, have the heads cleaned at the nearest Sony facility. •If you used a commercially available wet-type cleaning cassette, it may have damaged the video heads. •The video heads are worn out. •Adjust SHARPNESS.

	Symptom	Possible causes and remedies
Recording and playback	The picture moves vertically during picture search mode.	Adjust the vertical hold control on the TV or color monitor.
	Distorted or noisy sound	REC LEVEL was not properly adjusted.
	Sound drop-out	<ul style="list-style-type: none"> •The tape is defective. •Use a new video cassette tape.
	Stereo recording cannot be made.	AUTO STEREO is set to OFF in the MODE SET menu.
	Both main and SAP sounds are heard when playing back a tape on which an MTS broadcast was recorded.	AUDIO MIX is set to ON in the MODE SET menu.
	No sound is recorded on the normal audio track	NORMAL AUDIO is set to SAP in the MODE SET menu when there is no SAP broadcast.
Timer recording	Timer setting cannot be made.	The current time has not been preset.
	The TIMER indicator disappears even though you pressed TIMER REC ON/OFF .	<ul style="list-style-type: none"> •No cassette has been inserted. •The tape is at its end. •No timer recording setting is set.
	The cassette is ejected when you press TIMER REC ON/OFF .	The safety tab of the cassette has been broken off.
	Timer recording was not made.	<ul style="list-style-type: none"> •There had been a power interruption of 3 hours or more. •TIMER REC ON/OFF was not pressed.
Data screen	The data screen does not appear.	<ul style="list-style-type: none"> •Press DATA SCREEN. •The TV or color monitor is connected through the LINE OUT VIDEO jack.
Others	Cassette cannot be inserted.	Another cassette is already in the compartment.
	The Commander cannot be operated.	<ul style="list-style-type: none"> •COMMAND MODE has not been set correctly. •The batteries are exhausted.
	When trying to operate the VCR with the Commander, the VCR beeps.	<p>The beep shows that the operation is not possible.</p> <p>Ex.</p> <ul style="list-style-type: none"> •When you try to preset channels during recording •When you try to execute the AUTO MENU or AUTO REPEAT function during playback •When you try to set a timer recording before setting the clock

Specifications

System

Video recording system	Rotary two-head helical scanning FM system
Audio recording system	Rotary two-head hi-fi system (Recording on the conventional audio track is monaural)
Video signal	EIA standard, NTSC color
Tape speed	SP: 33.35mm/sec. (1 1/4 inches/sec.) EP: 11.11mm/sec. (3/8 inch/sec.) LP: 16.67mm/sec. (11/16 inch/sec.) (playback only)
Maximum recording/playback time	8 hours (EP) (T-160)
Fast-forward and rewind time	Approx. 4 min. (T-120)
HIGH SPEED REWIND time	Approx. 2 min. 30 sec. (T-120)
Audio frequency response	20 Hz — 20 kHz
Dynamic range	More than 90 dB
Wow and flutter	Less than 0.005%

Tuner section

Tuner system (audio)	Split inter carrier system
Channel coverage	VHF channels 2 to 13 UHF channels 14 to 69 CATV channels A-8 to A-1 A to W, W+1 to W+84
Antenna	75-ohm antenna terminal for VHF/UHF

INPUT and OUTPUT

LINE IN 1 and 2	VIDEO IN (phono jack) (1 each) Input signal: 1 Vp-p, 75 ohms, unbalanced, sync negative AUDIO IN (phono jack) (2 each) Input level: -7.5 dBs (0 dBs = 0.775 Vrms) Input impedance: more than 47 kilohms
LINE OUT	VIDEO OUT (phono jack) (1) Output signal: 1 Vp-p, 75 ohms, unbalanced, sync negative AUDIO OUT (phono jack) (2) Standard output: -7.5 dBs at load impedance 47 kilohms Output impedance: less than 10 kilohms
MONITOR OUT	VIDEO OUT (phono jack) (1) Output signal: 1 Vp-p, 75 ohms, unbalanced, sync negative AUDIO OUT (phono jack) (2) Standard output: -7.5 dBs at load impedance 47 kilohms Output impedance: less than 10 kilohms
CONTROL S IN	Minijack (1)
HEADPHONES jack	Stereo minijack (1) Output impedance: more than 8 ohms Output level: 45 mW at load impedance 8 ohms

Timer section

Clock	Quartz locked
Time indication	12-hour cycle
Timer setting	Only for recording
Power back up	8 programs over one month at max. Built-in self-charging battery Back-up duration: Up to 3 hours at one time

General

Power requirements	120V AC, 60 Hz
Power consumption	32 W
Operating temperature	5°C to 40°C (41°F to 104°F)
Storage temperature	-20°C to 60°C (-4°F to 140°F)
Dimensions	430 × 96.5 × 405 mm (w/h/d) (17 × 3 7/8 × 16 inches)
Weight	Approx. 6.5 kg (14 lbs 5 oz)

Wireless Commander RMT-V575A

Remote control system	Infrared control
Command mode	VTR1/VTR2/VTR3 selectable
Power requirements	3V DC, 2 size AA batteries (IEC designation R6)
Dimensions	72 × 20 × 200 mm (w/h/d) (2 7/8 × 13/16 × 7 7/8 inches)
Weight	120 g (4.2 oz) (excluding batteries)

Accessories supplied

Wireless commander RMT-V575A with two size AA batteries (IEC designation R6)	(1)
75-ohm coaxial cable with F-type connectors	(1)
Audio/video connecting cable (3 phono to 3 phono)	(1)
External antenna connector	(1)

Design and specifications are subject to change without notice.