



DLP TV

Chassis : L64E(N)_Iris
Model : HLS4676SX/XAA

SERVICE Manual

DLP TV



HL-S4676S

FEATURES

- HD Built in TV
- NTSC/ATSC Tuner Embedded
- PC input
- DNle 3 Adopted
- 2HDMI Interface Adopted
- Digital Audio output (OPTICAL) jack
- Firmware upgrade by USB Port
- USB 1.1 portable device Correspondence



This Service Manual is a property of Samsung Electronics Co.,Ltd.
Any unauthorized use of Manual can be punished under applicable
International and/or domestic law.

© Samsung Electronics Co., Ltd. **Sep. 2006**
Printed in Korea
AA82-03943A

Table of Contents

Chapter 1 Precaution

■ 1-1 Safety Precautions	1-1
■ 1-2 Servicing Precautions	1-3
■ 1-3 Static Electricity Precautions	1-4
■ 1-4 Installation Precautions	1-5

Chapter 2 Product Specification

■ 2-1 Product Features	2-1
■ 2-2 Key Features	2-2
■ 2-3 Specifications Analysis	2-4
■ 2-4 Accessories	2-5

Chapter 3 Alignment & Adjustment

■ 3-1 Service Instruction	3-1
■ 3-2 How to Access Service Mode	3-2
■ 3-3 Factory Data	3-3
■ 3-4 Service Adjustment	3-11
■ 3-5 Software Upgrade	3-14
■ 3-6 Replacements & Calibration	3-15

Chapter 4 Exploded View & Part List

■ 4-1 HLS4676SX/XAA	4-1
---------------------------	-----

Chapter 5 Electrical Part List

■ 5-1 HLS4676SX/XAA Service Item	5-1
--	-----

Chapter 6 Troubleshooting

■ 6-1 Checkpoints by Error Mode	6-1
■ 6-2 Troubleshooting Procedures by Error Modes	6-7
■ 6-3 Troubleshooting Procedures by ASS'Y	6-8

Chapter 7 Block Diagram

■ 7-1 Overall Block Diagram	7-1
■ 7-2 Partial Block Diagram	7-2

Chapter 8 Wiring Diagram

■ 8-1 Overall Wiring	8-1
■ 8-2 Connector of Main Board	8-3

Chapter 9 PCB Diagram

■ 9-1 Power Board	9-1
■ 9-2 Main Board	9-2
■ 9-3 DMD Board	9-5

Chapter 10 Schematic Diagram

■ 10-1 Main Board	10-1
■ 10-2 DMD Board	10-21
■ 10-3 Power Board	10-30
■ 10-4 Key Control	10-31
■ 10-5 LED	10-31
■ 10-6 RMC	10-32

1. Precaution

To avoid possible damages or electric shocks or exposure to radiation, follow the instructions below with regard to safety, installation, service and ESD.

1-1 Safety Precautions

1. Make sure all protective devices are properly installed including non-metallic handles and compartment covers when installing or re-installing the chassis or chassis assemblies.
2. Make sure that no gaps exist between the cabinets for children to insert their fingers in to prevent children from receiving electric shocks.

Errors may occur when the resistance is below 1.0 M Ω or over 5.2 M Ω .

In these cases, make sure that the device is repaired before sending it back to the customer.

3. Check for Electricity Leakage (Figure 1-1)
Warning: Do not use an insulated transformer for checking the leakage. Use only those current leakage testers or mirroring systems that comply with ANSIC 101.1 and the Underwriter Laboratory's specifications (UL1410, 59.7).

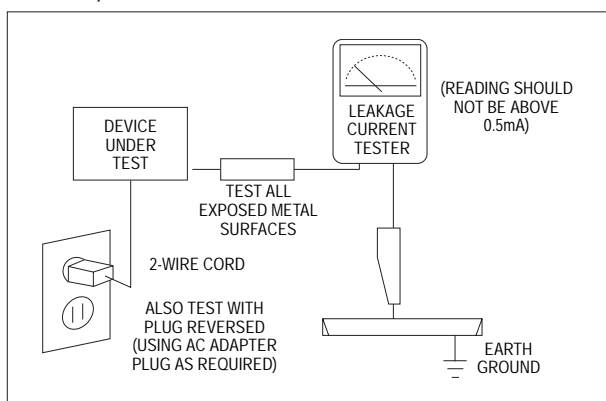

Fig. 1-1 AC Leakage Test



4. A high voltage is maintained within the specified limits using safety parts, calibration and tolerances. When voltage exceeds the specified limits, check each special part.
5. Warning for Engineering Changes:
Never make any changes or additions to the circuit design or the internal part for this product.
Ex: Do not add any audio or video accessory connectors. This might cause physical damage.
Furthermore, any changes or additions to the original design/engineering will invalidate the warranty.
6. Warning - Hot Chassis:
Some TV chassis are directly connected to one end of the AC power cord for electrical reasons.
Without insulated transformers, the product can only be repaired safely when the chassis is connected to the earthed end of the AC power source.

To make sure the AC power cord is properly connected, follow the instructions below. Use the voltmeter to measure the voltage between the chassis and the earthed ground. If the measurement is over 1.0V, unplug the AC power cord and change the polarity before re-inserting it. Measure the voltage between the chassis and the ground again.
7. Some TV chassis are shipped with an additional secondary grounding system. The secondary system is adjacent to the AC power line. These two grounding systems are separated in the circuit using an unbreakable/unchangeable insulation material.
8. When any parts, material or wiring appear overheated or damaged, replace them with new regular ones immediately. When any damage or overheating is detected, correct this immediately and make a regular check of possible errors.
9. Check for the original shape of the lead, especially that of the antenna wiring, any sharp edges, the AC power and the high voltage power. Carefully check if the wiring is too tight, incorrectly placed or loose. Never change the space between the part and the printed circuit board. Check the AC power cord for possible damages. Keep the part or the lead away from any heat-emitting materials.

Precaution

10. Safety Indication:

Some electrical circuits or device related materials require special attention to their safety features, which cannot be viewed by the naked eye. If an original part is replaced with another irregular one, the safety or protective features will be lost even if the new one has a higher voltage or more watts.

Critical safety parts should be bracketed with ( ). Use only regular parts for replacements (in particular, flame resistance and dielectric strength specifications). Irregular parts or materials may cause electric shock or fire.

11. Pay additional attention to the current leakage as the voltage between the power board and the ballast is 220 to 440v, i.e. very high.
And also beware of possible electric shock from the primary power source.

1-2 Servicing Precautions

Warning 1: First carefully read the "Safety Instruction" in this service manual.

When there is a conflict between the service and the safety instructions, follow the safety instruction at all times.

Warning 2: Any electrolytic capacitor with the wrong polarity will explode.

1. The service instructions are printed on the cabinet, and should be followed by any service personnel.
2. Make sure to unplug the AC power cord from the power source before starting any repairs.
 - (a) Remove or re-install parts or assemblies.
 - (b) Disconnect the electric plug or connector, if any.
 - (c) Connect the test part in parallel with the electrolytic capacitor.
3. Some parts are placed at a higher position than the printed board. Insulated tubes or tapes are used for this purpose. The internal wiring is clamped using buckles to avoid contact with heat emitting parts. These parts are installed back to their original position.
4. After the repair, make sure to check if the screws, parts or cables are properly installed. Make sure no damage is caused to the repaired part and its surroundings.
5. Check for insulation between the blade of the AC plug and that of any conductive materials (i.e. the metal panel, input terminal, earphone jack, etc).
6. Insulation Check Process: Unplug the power cord from the AC source and turn the switch on. Connect the insulating resistance meter (500v) to the AC plug blade.

The insulating resistance between the blade of the AC plug and that of the conductive material should be more than 1 M Ω .
7. Any B+ interlock should not be damaged. If the metal heat sink is not properly installed, no connection to the AC power should be made.
8. Make sure the grounding lead of the tester is connected to the chassis ground before connecting to the positive lead. The ground lead of the tester should be removed last.
9. Beware of risks of any current leakage coming into contact with the high-capacity capacitor.
10. The sharp edges of the metal material may cause physical damage, so ensure wearing protective gloves during the repair.

1-3 Static Electricity Precautions

1. Some semi-conductive ("solid state") devices are vulnerable to static electricity. These devices are known as ESD. ESD includes the integrated circuit and the field effect transistor. To avoid any materials damage from electrostatic shock, follow the instructions described below.
2. Remove any static electricity from your body by connecting the earth ground before handling any semi-conductive parts or ass'ys. Alternatively, wear a dischargeable wrist-belt.
(Make sure to remove any static electricity before connecting the power source - this is a safety instruction for avoiding electric shock)
3. Remove the ESD ass'y and place it on a conductive surface such as aluminum foil to prevent accumulating static electricity.
4. Do not use any Freon-based chemicals. Such chemicals will generate static electricity that causes damage to the ESD.
5. Use only grounded-tip irons for soldering purposes.
6. Use only anti-static solder removal devices. Most solder removal devices do not support an anti-static feature. A solder removal device without an anti-static feature can store enough static electricity to cause damage to the ESD.
7. Do not remove the ESD from the protective box until the replacement is ready. Most ESD replacements are covered with lead, which will cause a short to the entire unit due to the conductive foam, aluminum foil or other conductive materials.
8. Remove the protective material from the ESD replacement lead immediately after connecting it to the chassis or circuit ass'y.
9. Take extreme caution in handling any uncovered ESD replacements. Actions such as brushing clothes or lifting your leg from the carpet floor can generate enough static electricity to damage the ESD.

CAUTION

These servicing instructions are for use by qualified service personnel only. To reduce the risk of electric shock do not perform any servicing other than that contained in the operating instructions unless you are qualified to do so.

1-4 Installation Precautions

1. For safety reasons, more than two people are required for carrying the product.

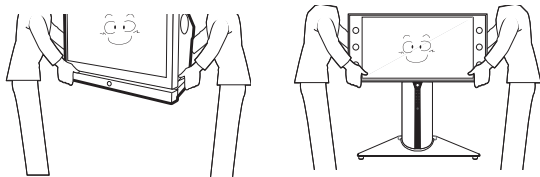

2. Keep the power cord away from any heat emitting devices, as a melted covering may cause fire or electric shock.
3. When installing the product, make sure to keep it away from the wall (more than 10cm/4 inches spacing should be around the Top, Back, and both sides of the unit) for ventilation purposes.
Poor ventilation may cause an increase in the internal temperature of the product, resulting in a shortened component life and degraded performance.
4. Bend the external antenna cable when connecting it to the product. This is a measure to protect it from being exposed to moisture. Otherwise, it may cause a fire or electric shock.
5. Make sure to turn the power off and unplug the power cord from the outlet before repositioning the product. Also check the antenna cable or the external connectors if they are fully unplugged. Damage to the cord may cause fire or electric shock.
6. Keep the antenna far away from any high-voltage cables and install it firmly. Contact with the high-voltage cable or the antenna falling over may cause fire or electric shock.
7. When connecting the RF antenna, check for a DTV receiving system and install a separate DTV reception antenna for areas with no DTV signal.
8. Check the basics of the screen test.
- Image position/size, Tilt adjustment, Actuator activation

MEMO

2. Product Specification

2-1 Product Features

Block	Specification	Major IC	Remark
DMD	- Panel Resolution : 1280 x 720 (Diamond Pixel)	HD5 DMD Panel(K520 Engine)	
RF	- VSB Half Nim Tuner (ATSC/NTSC system)	DTVS305CV201A	
Power	- Input Voltage : AC110V - Stand-By : under 1W	Stand-by (KA1M0565)	
Video	- Component interface : 480i/480p/720p/1080i - Digital interface : 2 HDMI In (DVI Comportable with adaptive jack only) - DNle	ATI X240H, MST3389, DNle 3	
Sound	- Speaker : 10W X 2 - SRS TruSurround XT	STV8258	
Cabinet	- K5 Design		

■ Chip Description

- ATI X240H : Xilleon 240H (X240S & X240H) integrate the functions necessary to implement a digital television receiver with a minimum number of external components. The X240S/H receives DTV signals from an off-air or cable tuner, analog signals from an off-air tuner, cable tuner, or external CVBS or S-Video inputs, and digital video signals via an ITU-R BT.656 or 24-bit digital interface. All of the necessary functions are included to process the video, add graphics, perform HD or SD MPEG decode, and generate analog, 24-bit digital, or ITU-R BT.656 outputs.
- MST3389 : The MST3389 integrates both analog interfaces and DVI/HDMI compliant receivers for enabling advanced digital display devices such as digital TVs, plasma displays, LCD TVs and projectors to receive and display motion video and computer graphics inputs. Compliant with the HDMI 1.0 specification, the MST3389 enables consumer electronic devices to receive uncompressed, high quality, digital audio and video HD content over a single, low-cost HDMI cable. The MST3389 is available in a 160-pin PQFP package.
- STV8258 : The STV8258 based on audio digital signal processors (DSP), performs high quality and advanced dedicated digital audio processing. These devices provide all of the necessary resources for automatic detection and demodulation of analog audio transmissions for European and Asian terrestrial TV broadcasts.
- DNle 3 : The 12 algorithms are applied in DNle-PRO. The 7 secondary algorithms which are NR(Noise Reduction), DE(Detail Enhancement), CE(Contrast Enhancement), WTE(White-tone Enhancement), DCE(Detail Contrast Enhancement), BWS(Black & White Stretch) and CTE(Color Tone Enhancement), and the rest, NE(Noise Estimator), CVD(Color Vision Deficiency), ISBC, PCC(Preferred Color Control), SD3(3-SD H scaler).

2-2 Key Features

Model	HLS4676S
Voltage	AC 110-120V~
Frequency of Operation	60Hz
Power Consumption	200 watts
Dimensions (W x D x H)	41.26 x 11.14 x 29.21 inches 1048 x 283 x 741 mm
Weight	21 Kg / 46.29 lbs

■ H/W Configuration

- DMD Panel : 0.45" (1280 x 720p, TI)
- 1 Optical Engine for the Panel : Slim and Cost-effective
- Color Wheel : R/G/B/Y/C Color Implementation
- Lamp : 132W (10,000 hours) → Dynamic Mode 150W Drive (6,000 hours)
- Support HDMI Interface : Adopts DVI/HDMI systems for digital HDs including STB.
- DNle3 : High quality image implementation
- USB Interface : Adopts WiseLink(USB1.1)

■ S/W Configuration

- MCU : Built-in 264 MHz MIPS X240H CPU
- 4-Layered Architecture : Device Driver/OS/Hardware Abstraction/Application
- OSD : 32Bit True Color Graphics OSD
- Enhanced system stability by separating the DTV control and the application control systems into multi-processes.

■ Picture

- DMD Panel
 - * Panel Size : 0.45"
 - * Panel Resolution : 1280 x 720 (Diamond Pixel)
- Tuner : Integrated HDTV Tuner (NTSC/ATSC TUNER Embedded)
- Display Format : 1280 x 720 (Diamond Pixel)

■ Sound

- Sound System : Dolby Digital
- Amp/Channel : 2 Channel Digital Amp
- Speaker System & Output(RMS)
 - * Main L/R : 10W + 10W
 - * Sound (RMS) : 10W + 10W

■ In/Out Terminals

- Side : 2 RF In, 2 CVBS In, 2 S-VHS In, 2 Component In, 2 HDMI In(DVI compatible With Adaptive Jack Only), 1 Optical audio out, 1 Monitor out, 1 PC in, Wiselink

■ Feature

- Component Interface (480i/480p/720p/1080i, Y/Pb/Pr)
- Digital Interface : 2 HDMI In(DVI compatible with adaptive jack only)
- Language : English/French/Spanish
- Picture Size : 4:3/16:9/Zoom1/Zoom2/Wide Fit
- V-CHIP
- Closed Caption
- Sleep Timer : 180 Min.
- Optical sound output
- Game mode
- PC input
- Wiselink





■ Remocon

- TM87B









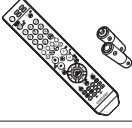

■ Power Supply

- 110V

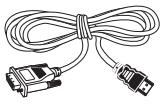
2-3 Specifications Analysis

Model		HL-S4676S	HL-S5686W	HL-S6186W	HL-R5087W	HL-R4266W
Design						
Picture	Display Device	DLP	DLP	DLP	DLP	DLP
	Built-in Tuner	ATSC, NTSC	ATSC, NTSC	ATSC, NTSC	ATSC, NTSC	ATSC, NTSC
	Display Format	1080i, 720p, 480p, 480i	1080i, 720p, 480p, 480i	1080i, 720p, 480p, 480i	1080i, 720p, 480p, 480i	1080i, 720p, 480p, 480i
	Screen Size	46 inch	56 inch	61 inch	50 inch	42 inch
	Aspect ratio	16:9	16:9	16:9	16:9	16:09
	Progressive scan	Yes	Yes	Yes	Yes	Yes
	Digital Comb Filter	3D Comb	3D Comb	3D Comb	3D Comb	4H Comb
	First Surface Mirror	Yes	Yes	Yes	Yes	Yes
	Brightness	750cd/m ²	750cd/m ²	750cd/m ²	800cd/m ²	750cd/§ ³
	Contrast	2000:1	1500:1	1500:1	2500:1	1500:1
	Color Wheel Size/Bearing	55mm/5segment/air bearing	55mm/5segment/air bearing	55mm/5segment/air bearing	7segment/65 φ , Air Bearing	7segment/65φ0 Air Bearing
	Anti-glare Sun Screen	No	No	No	No	No
	Screen Pitch	0.224mm	0.224mm	0.224mm	0.098mm	0.098mm
	Image enhancer	DNle3	DNle3	DNle3	DNle3	DNle3
Audio	Base/Tremble/Balance	No	No	No	No	No
	Equalizer	5 Band	5 Band	5 Band	5 Band	5 Band
	Auto Volume Leveler	Yes	Yes	Yes	Yes	Yes
	Surround Sound	TruSurround XT Dolby Digital	TruSurround XT Dolby Digital	TruSurround XT Dolby Digital	TruSurround XT Dolby Digital	DNSE Dolby Digital
	Speaker system	2Way 2Speaker	2Way 2Speaker	2Way 2Speaker	2 Way 4 Speaker	2 Way 4 Speaker
	Output Power	10Wx2	10Wx2	10Wx2	15Wx2	15Wx2
Features	2-Tuner Split-Screen PIP	No	No	No	Yes(HD/SD)	Yes(HD/SD)
	Split-screen Side-by-Side	No	No	No	Yes	Yes
	MTS with dbx Noise Reduction/SAP	Yes	Yes	Yes	Yes	Yes
	Still Picture	Yes	Yes	Yes	Yes	Yes
Connections	Plug & Play	Yes	Yes	Yes	Yes	Yes
	EPG	No	No	No	Gemstar EPG	No
	Anynet	No	No	No	Yes	Yes
	S-Video In	Rear 2	Rear2/Side1	Rear2/Side1	Rear 2	Rear 2/Side 1
	HDTV Component Video Input (Y, Pb, Pr) 1080i/480P/480i	Rear 2	Rear 2	Rear 2	Rear 2	Rear 2
	PC	yes	yes	yes	No	No
	HDMI	2HDMI	2HDMI	2HDMI	Yes	Yes
	Digital Sound	Optical 1	Optical 1	Optical 1	Optical 1	Optical 1
Wiselink	yes	yes	yes	No	No	

2-4 Accessories

	Accessories	Item	Item code	Remark
Supplied Accessories		Remocon Alkaline Battery	BP59-00107A 4301-000103	Samsung Service center
		Manual	BP68-00617A	
		Power Cord	3903-000144	
		Warranty Card	AA68-01561A	
		Cloth-Clean	BN63-01798A	
Accessories that can be purchased additionally		HDMI/DVI cable	-	Internal shopping mall
		HDMI Cable	-	
		S-VIDEO Cable	-	
		Optical Cable	-	
		Antenna Cable	-	
		Component Cables (RCA)	-	

MEMO

3. Alignment & Adjustment

3-1 Service Instruction

■ Check items listed after changing each

Replaced Items \ Check Items	S/W Version	Front LED	Index Delay	Actuator Gain	V-Position H-Position	CCA	Board LED	Tilt Focus
Main Board	● (1st)		● (3rd)	● (5th)	● (2nd)	● (4th)		
Power Board		●					●	
Optical Engine		●	● (3rd)	● (5th)	● (2nd)	● (4th)		● (1st)
DMD Board				●				●
Lamp								
Color Wheel			●					
Front LED Assy		●						

※ If you change Main Board and optical engine, check in order.
(For example, in case of "Main Board", first 'S/W', second 'V/H position' and third 'Index'...)

1. Software version check :

After Entering the Service mode, Check the list below

* S/W Notation

"T_EINLUS0-XXXX" indicates "IRIS BASIC MODEL USA, ver. XXXX".

2. Front LED check : In this S/M it is page 6-8

3. Index Delay adjustment : See page 3-11.

4. Actuator Gain adjustment : See page 3-13.

5. Vertical / Horizontal Position adjustment : See page 3-11.

6. CCA : See page 3-12.

7. Board LED check : Check all the LED are turned on.

T-EINLUS0-XXXX
T-EINLUS5-XXXX
ACL xx.xx.xx
RFS....
20xx-xx-xx
TL-DSP-xxxx

8. Tilt/Focus adjustment : See page 3-15.

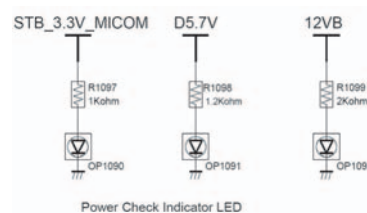

3-2 How to Access Service Mode

1. Turn off the power to put the unit into the STAND-BY mode.
2. In order to enter the Service Mode, Press "Mute" → "1" → "8" → "2" → "POWER" button on the Remote Control.
In case entry into SERVICE MODE is unsuccessful, repeat the procedures above.
3. Initial DISPLAY State in times of Service Mode Switch overs

Option
DDP3021(K520)
CCA(ON)
SP Actuator
DNle
X240
X240 NTSC
MST3389
STV8258DSX
Cinema CCA
ESP
CHECKSUM
SERVICE

T-EINLUS0-XXXX
T-EINLUS5-XXXX
ACL xx.xx.xx
RFS....
20xx-xx-xx
T-LEEUM-xxxx

4. Buttons operations within Service Mode

MENU	Full Menu Display / Move to Parent Menu/ Move to upper menu
Direction keys ▲ / ▼	Item Selection by Moving the Cursor
Direction keys ◀ / ▶	Data Increase/Decrease for the Selected Item
Source	Cycles through the active input source that are connected to the unit
Enter	Item Selection/execution

3-3 Factory Data

★ The underlined are items applied during the service adjustment. None of the others should be adjusted.

1. OPTION

No	Item	Range	Default	Remark
1	<u>Factory Reset</u>			All setting is back to the factory setting
2	Lamp Control	Dynamic/always	Dynamic	Dynamic, Always
3	WB Reset	on/off	OFF	Initialize the White Balance value
4	EER Reset			Clear the EEPROM
5	<u>User Reset</u>			All setting is back to the default
6	<u>DIGITAL →DMD</u>			Transfer engine adjustment data from digital to DMD
7	Lamp Clear			Clear the Lamp life time
8	Lamp life		0h	Lamp on time counter
9	AUTO POWER	on/off	ON	on/off
10	MUTE TIME		600ms	Time which the screen will be black while switching channels
11	EDID WRITE			Sound Delay Module ON/OFF selection
12	DELAY MOD	on/off	OFF	Sound Delay Module ON/OFF selection
13	DBG/ANY SEL	Debug/Anynet	Debug	Select the use of the Service jack
14	DDC Protection	on/off	ON	DDC write ON/OFF selection
15	Downloadable RRS	on/off	ON	Downloadable RRS on/off selection
16	PROTECT	on/off	ON	Protection ON/OFF selection
17	WATCH DOG	on/off	ON	Watch Dog ON/OFF selection
18	WD COUNT		0	Count for Watch Dog event
19	HDCP HPD	on/off	on	HDMI/DVI HOT PLUG Control
20	Melody vol	0~10	2	Melody Volume Control
21	<u>Test Pattern(GR)</u>			scaler test pattern
22	<u>DMD →Digital</u>			Transfer engine adjustment data from DMD to digital
23	PC Ident	Auto/enable	Auto	PC indent mode
24	Shop Mode	On/Off	On	Shop mode selection

2. DDP3021(K520)

No	Item	Range	Default	Remark
1	<u>V-Position</u>	0-60	30	Screen upper and lower adjustment
2	<u>H-Position</u>	0~120	60	Screen left and right adjustments
3	LAMP SYNC		Pulse	Pulse(P), Pass(T)
4	<u>INDEX DELAY</u>	0~359	30	Synchronizes the base position of the color wheel with the corresponding color signal. This is critical to the natural color display. If the index delay is not properly set, even the correct CCA coordinates will not help when displaying natural colors.
5	SEQ SELECT	-	-	Sequence Selection
6	<u>V-FLIP</u>	Normal/Flip	Flip	Vertical Flip Operation
7	<u>H-FLIP</u>	Normal/Flip	Flip	Horizontal Flip Operation
8	GAMMA	0 ~ 15	4	Gamma Table Selection
9	MPC	OFF/ON	ON	MPC Function On/Off
10	DMD_BIAS	-	-	DMD Bias pin voltage selection
11	Lamp Boost	-	-	Lamp Boost value selection
12	Lamp Sync Delay	0~4095	120	Lamp Sync delay value selection
13	Version		0x1	
14	Optic Select	-	-	SAMSUNG and ZEISS Selection
15	<u>Lamp Select</u>		Philips	Philips/Osram/Ushio
16	Optic detect	-	K520	Optic Detect Select
17	Lamp Watt		132W	120W/132W Selection
18	<u>Test Pattern(DDP)</u>		0	This displays the built-in pattern of the DDP3021 chip. DDP3021 drives the DMD panel, so displaying this pattern means there is no error in the DDP3021 projection function and the panel itself.

3. CCA(ON)

No	Item	Range	Default	Remark
1	<u>CCA</u>	On/Off	On	CCA On/Off Selection
2	Red-x	0~32768	660	Red-x adjustment
3	Red-y	0~32768	320	Red-y adjustment
4	Red-Y	0~32768	90	Red-Y adjustment
5	Green-x	0~32768	280	Green-x adjustment
6	Green-y	0~32768	685	Green-y adjustment
7	Green-Y	0~32768	210	Green-Y adjustment
8	Blue-x	0~32768	148	Blue-x adjustment
9	Blue-y	0~32768	58	Blue-y adjustment
10	Blue-Y	0~32768	60	Blue-Y adjustment
11	White-x	0~32768	274	White-x adjustment
12	White-y	0~32768	285	White-y adjustment
13	White-Y	0~32768	700	White-Y adjustment
14	Yellow-x	0~32768	469	Yellow-x adjustment
15	Yellow-y	0~32768	525	Yellow-y adjustment
16	Yellow-Y	0~32768	286	Yellow-Y adjustment
17	Cyan-x	0~32768	170	Cyan-x adjustment
18	Cyan-y	0~32768	290	Cyan-y adjustment
19	Cyan-Y	0~32768	146	Cyan-Y adjustment
20	<u>WB Spread</u>			Spread CCA value to all mode
21	DRedX	0~32768	660	Target Red X value for CCA
22	DRedY	0~32768	320	Target Red Y value for CCA
23	DGreenX	0~32768	280	Target Green X value for CCA
24	DGreenY	0~32768	685	Target Green Y value for CCA
25	DBlueX	0~32768	148	Target Blue X value for CCA
26	DBlueY	0~32768	58	Target Blue Y value for CCA
27	DCyanX	0~32768	170	Target Cyan X value for CCA
28	DCyanY	0~32768	290	Target Cyan Y value for CCA
29	DMagentaX	0~32768	291	Target Magenta X value for CCA
30	DMagentaY	0~32768	123	Target Magenta Y value for CCA
31	DYellowX	0~32768	467	Target Yellow X value for CCA
32	DYellowY	0~32768	525	Target Yellow Y value for CCA
33	D_White_X	0~32768	274	Target White X value for CCA
34	D_White_Y	0~32768	285	Target White Y value for CCA

4. SP Actuator

No	Item	Range	Default	Remark
1	<u>Actuator Gain</u>	0~175	60	Actuator Gain adjustment
2	<u>Actuator On/Off</u>		On	Actuator On/Off selection

5. DNle

No	Item	Range	Default	Remark
1	<u>Test Pattern</u>		0	Test Pattern Selection
2	NR_MAX Y/C	0~255	32	Temporal NR Gain
3	NR_MIN Y/C	0~255	16	Temporal NR Gain
4	B_RATIO		12000	Low level information for the minimum value
5	BLACK_TILT	0~255	128	Black Stretch Area
6	GAIN1X	0~63	10	Gain of horizontal high frequency region
7	GAIN1Y	0~63	8	Gain of vertical high frequency region
8	GAIN2X	0~63	10	Gain of horizontal middle frequency region
9	GAIN2Y	0~63	4	Gain of vertical middle frequency region
10	GAIN3X	0~63	1	Gain of horizontal low frequency region
11	SCALE_R	0~255	50	Log Mapping Gain
12	RED_C_COEFF		126	Gain adjustment of the contrast for the Red signal
13	GRN_C_COEFF		128	Gain adjustment of the contrast for the Green signal
14	BLU_C_COEFF		127	Gain adjustment of the contrast for the Blue signal
15	RED_B_COEFF		128	Gain adjustment of the brightness for the Red signal
16	GRN_B_COEFF		128	Gain adjustment of the brightness for the Green signal
17	BLU_B_COEFF		128	Gain adjustment of the brightness for the Blue signal
18	ALPMAU/L	0~255	50	
19	Sub Contrast	0~150	110	Brightness adjustment for the high-light parts of the screen
20	Sub Brightness		221	Brightness adjustment for the low-light parts of the screen
21	Sub offset	0~255	255	
22	MATR_CRR		800	
23	MATR_CBG		1820	
24	MATR_CRG		1792	
25	MATR_CBB		1023	
26	B_GAIN_MAX		390	

6. X240

No	Item	Range	Default	Remark
1	Main/Sub	Main/Sub	Main	
2	Y/UV	Y/UV	Y	
3	Filter		gh121a	

7. X240 NTSC

No	Item	Range	Default	Remark
1	IN PHASE LINE	0 ~ 31	24	In Phase Line sensitivity for the Comb filter
2	IN PHASE FRAME	0 ~ 31	26	In Phase Frame sensitivity for the Comb filter
3	OUT PHASE LINE	0 ~ 31	12	Out Phase Line sensitivity for the Comb filter
4	OUT PHASE FRAME	0 ~ 31	22	Out Phase Frame sensitivity for the Comb filter
5	CORING	0 ~ 63	4	HP luma coring level of a 10bit luma signal.
6	LUMA_BW	0 ~ 3	0	Luma Bandwidth Limitation(0-None ; 1-Low ; 2-Medium ; 3-Forced)
7	CHROMA_BW	0 ~ 4	4	selection of the post chroma filtering
8	CKILL_TH1	(-)32 ~ 32	48	Unsigned offset for the minimum burst detection threshold.
9	CKILL_TH2	(-)32 ~ 32	80	Signed offset for the minimum burst detection threshold.
10	LUMA_GAIN	0 ~ 1023/10step	462	Luma gain 0x200 nominal value is 100%
11	LUMA_OFFSET	0 ~ 1023/10step	0	Luma offset zero nominal for 0 IRE
12	CR_GAIN	0 ~ 1023/10step	492	Cr gain 0x200 nominal value is 100%
13	CR_OFFSET	0 ~ 512/10step	0	Cr offset 0x000 nominal for 0 IRE
14	CB_GAIN	0 ~ 1023/10step	482	Cb gain 0x200 nominal value is 100%
15	CB_OFFSET	0 ~ 512/10step	0	Cb offset 0x000 nominal for 0 IRE
16	Y_DELAY_POS	0 ~ 65535	0	Enables over-write values for chroma & luma delays.
17	Y_DELAY_NEG	0 ~ 65535	12	First and second over-write delay at 27MHz for Y.
18	CR_DELAY_POS	0 ~ 65535	0	Third and forth over-write delay at 54MHz for Cb.
19	CR_DELAY_NEG	0 ~ 65535	13	First and second over-write delay at 54MHz for Cb.
20	CB_DELAY_POS	0 ~ 65535	0	Third and forth over-write delay at 54MHz for Cr.
21	CB_DELAY_NEG	0 ~ 65535	13	First and second over-write delay at 54MHz for Cr.
22	NOISE_ME	Read	0	Noise level(0: no noise, 3: high noise)
23	AGC_ON/OFF	0~3	OFF	Selection AGC on/off
24	AGC_GAIN		500	Adjust AGC gain.

8. MST3389(disable)

No	Item	Range	Default	Remark
1	RED CUTOFF	0 ~ 255	128	ADC R channel offset(lower value -> higher DATA out)
2	GREEN CUTOFF	0 ~ 255	128	ADC G channel offset(lower value -> higher DATA out)
3	BLUE CUTOFF	0 ~ 255	128	ADC B channel offset(lower value -> higher DATA out)
4	PHASE	0 ~ 64	0	Adjust ADC comparator(sampling) phase (64 steps).
5	RED GAIN		128	ADC R channel Gain. 00: Smallest input range, maximum gain.
6	GREEN GAIN		128	ADC G channel Gain. 00: Smallest input range, maximum gain.
7	BLUE GAIN		128	ADC B channel Gain. 00: Smallest input range, maximum gain.
8	PLLDIV	0 ~ 4096	127	ADC PLL Divider ratio
9	PLLGAIN	0 ~ 32	16	select ADC PLL VCO range and Charge pump current.
10	CLPDLY		16	Set Clamp Pulse Delay to HSYNC reference edge.
11	CLPDUR		8	Set Clamp Pulse width in pixel clock.
12	HSOPW		32	ADC HSOUT pulse width in pixel clock.
13	SYNC_CTRL		64	Set Sync control by various option.
14	SOGMID_CTRL		184	ADC R&B channel level select clamping level select.
15	SEP_THR		32	VSYNC separator Threshold in 5MHz(ADC).
16	PRECST		0	Pre-Coast width(before VSYNC) for COAST extension.
17	POSTCST		0	Pre-Coast width(after VSYNC) for COAST extension.
18	ADC_BW0		0	On-line ADC input 3dB Bandwidth for R&G channels.
19	ADC_BW1		0	On-line ADC input 3dB Bandwidth for B channels.

* This menu is not activated.

9. STV8258DSX

No	Item	Range	Default	Remark
1	Stereo Pilot high	0 ~ 255	35	Threshold High for Stereo Detection
2	Stereo Pilot low	0 ~ 255	16	Threshold Low for Stereo Detection
3	SAP Pilot high	0 ~ 255	128	Threshold high for SAP detection
4	SAP Pilot low	0 ~ 255	96	Threshold low for SAP detection
5	D_AV Delay	0 ~ 255	88	Set the delay time for LS channel.
6	A_AV Delay	0 ~ 255	88	Set the delay time for LS channel.
7	Carrier Mute		ON	
8	MTS Interval		1	

10. Cinema CCA

No	Item	Range	Default	Remark
1	DRedX		640	Target Red X value for CCA
2	DRedY		330	Target Red Y value for CCA
3	DGreenX		300	Target Green X value for CCA
4	DGreenY		600	Target Green Y value for CCA
5	DBlueX		150	Target Blue X value for CCA
6	DBlueY		60	Target Blue Y value for CCA
7	DCyanX		230	Target Cyan X value for CCA
8	DCyanY		415	Target Cyan Y value for CCA
9	DMagentaX		325	Target Magenta X value for CCA
10	DMagentaY		158	Target Magenta Y value for CCA
11	DYellowX		467	Target Yellow X value for CCA
12	DYellowY		525	Target Yellow Y value for CCA
13	D-White-X		313	Target White X value for CCA
14	D-White-Y		329	Target White Y value for CCA

11. ESP

No	Item	Range	Default	Remark
1	Dynamic Co Global	on/off	OFF	
2	Dynamic Co Local	on/off	OFF	
3	Dynamic Co Skin	on/off	OFF	
4	Dynamic Strength	Low/Medium/Max	Medium	
5	Dynamic Con Gain	0~100	0	
6	Dynamic Sat	on/off	OFF	
7	Dynamic Sat Gain	0~255	176	
8	Sharp Picture	on/off	OFF	
9	Sharp VLUT	TBD/Ugain	TBD	
10	Sharp Filter	HD Low/SD/UCF	HD Low	
11	Sharp Picture Gain	0~255	176	

12. CHECKSUM 0000

Excute Checksum calculation

13. SERVICE

No	Item	Range	Default	Remark
1	<u>V-Position</u>	0 ~ 60	30	Screen upper and lower adjustment
2	<u>H-Position</u>	0 ~ 120	60	Screen left right adjustment
3	<u>User Reset</u>			All setting is back to the default
4	<u>INDEX DELAY</u>	0 ~ 256	30	Index delay adjustment
5	LAMP SYNC	Pulse/Pass	Pulse	
6	<u>CCA</u>			CCA menu
7	<u>DMD→Digital</u>			
8	<u>Digital→DMD</u>			Transfer engine adjustment data from digital to DMD
9	Lamp Life		0h	Duration of use of lamp
10	Lamp clear			Lamp Life item does Reset
11	Mute time	490ms ~ 1000ms	600ms	
12	<u>Lamp Select</u>		Philips	Philips/Osram/Ushio
13	<u>Optic Select</u>		-	SAMSUNG and ZEISS Selection
14	Lamp Watt		132W	120W/132W Selection
15	<u>Actuator gain</u>		60	Adjust Actuator gain

3-4 Service Adjustment

3-4-1 Vertical / Horizontal Position Adjustment

1. Turn off the power to put the unit into the STAND-BY mode.
 2. In order to enter the Service Mode, Press "Mute" → "1" → "8" → "2" → "POWER" button on the Remote Control.
 3. Select "Service" on the first display of the Service mode menu.
 4. Select the V-position for vertical positioning and H-position for horizontal positioning by using the ▲ ▼ (up, down) buttons.
 5. Use Left & Right arrow buttons to adjust the V and H position.
- ※ Do not set the V-position value to 34 or 35. (Setting to these values will cause horizontal lines on the right side of the screen.)

3-4-2 INDEX DELAY Adjustment

1. Turn off the power to put the unit into the STAND-BY mode.
2. In order to enter the Service Mode, Press "Mute" → "1" → "8" → "2" → "POWER" button on the Remote Control.
3. Select "Service" on the first display of the Service mode menu.
4. Press the ▲ ▼ (Up or Down) button to move to INDEX DELAY, then press ENTER to select.
5. The INDEX DELAY setup screen (with 4 grayscale bars at the bottom of the screen) will be displayed.
6. Press the ◀ ▶ (Left of Right) button to adjust the red color (Green, Blue, White) at the bottom of the screen at its minimum and maximum values of changing from red to magenta, then adjust to the mean value.

3-4-3 CCA Adjustment Service Methods : CCA Adjustment is needed after changing a light engine or digital board

■ CCA : In DLP TV, even the same RGB color may differ depending on the light engine. CCA (Color Coordinate Adjustment) corrects the color to achieve the color accuracy. CCA performs color correction after measuring and inputting the current light engine's data on actual color coordinates for displayed Red, Green, Blue, and White color patterns, using a color coordinate measuring equipment. At this moment, color correction is performed below.

- 1) This procedure is needed if the Main PCB or DMD Board are changed.
- 2) If the DMD PCB is changed then you use the Digital→DMD adjustment item in the Option menu of service mode.

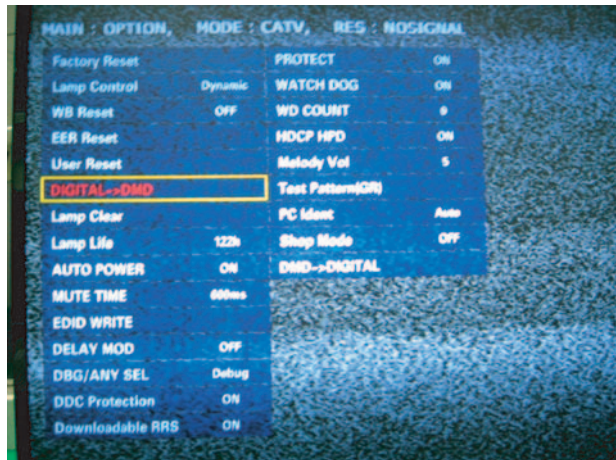
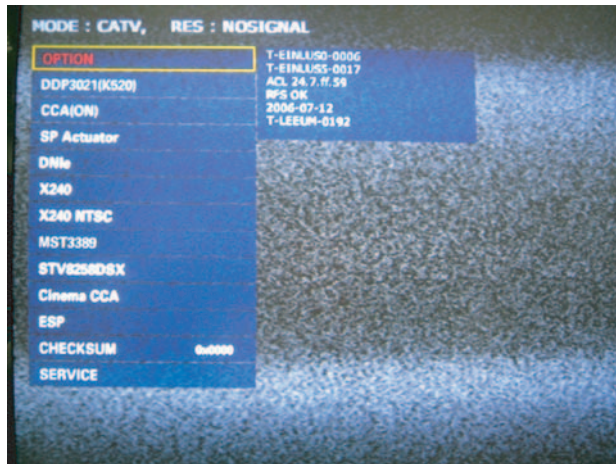

- 3) If the Main PCB is changed use the DMD→Digital adjustment.

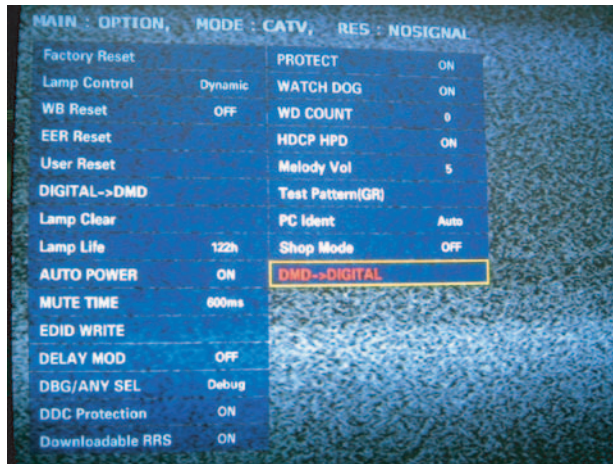

*** Attention**

Performing CCA is independent on current display's resolution and input signal type if you don't measure color coordinates data. Measuring color coordinates data requires specific equipment not possessed by service personnel, that makes performing manual adjustment impossible. Adjusting CCA is applied to all the signal mode. Don't change desired value because it will be harmful to the color of the SET. When the color wheel is changed, Don't performing CCA adjustment procedure. Adjust Index delay only.

3-4-4 ACTUATOR GAIN Adjustment

1. Before Adjustment

- 1) Turn off the power to put the unit into the STAND-BY mode.
- 2) In order to enter the Service Mode, Press "Mute" → "1" → "8" → "2" → "POWER" button on the Remote Control.
- 3) Select "Service" on the first display of the Service mode menu.
- 4) Press the ▲ ▼ (Up or Down) button to move to ACTUATOR GAIN, then press ENTER to select.
- 5) Use the Left and Right arrow buttons to adjust the ACTUATOR GAIN.

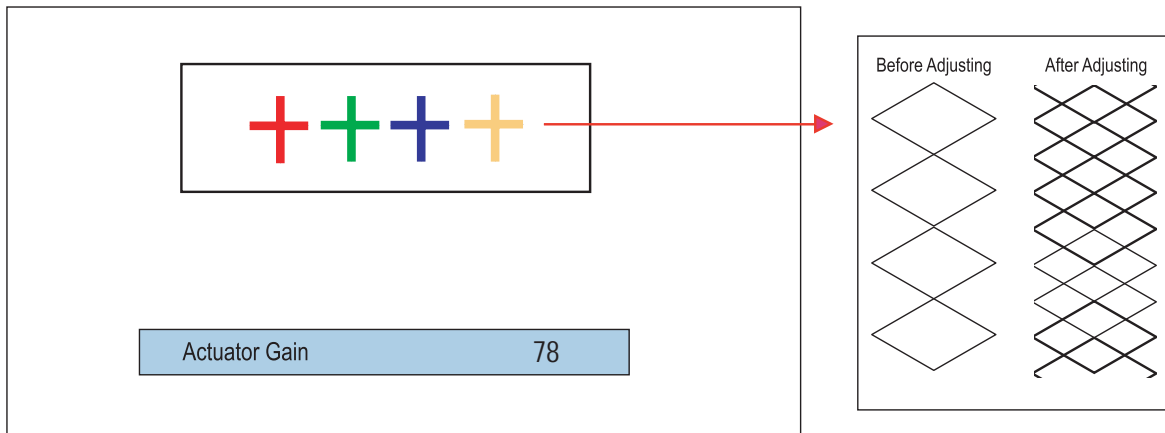

2. Making Adjustments

- 1) As shown in the picture above, change the actuator values to eliminate saw tooth shapes.
 - To fine tune, increase the data value ensuring that you get the center between the starting and ending points of the disappearing saw tooth shape.

3-5 Software Upgrade

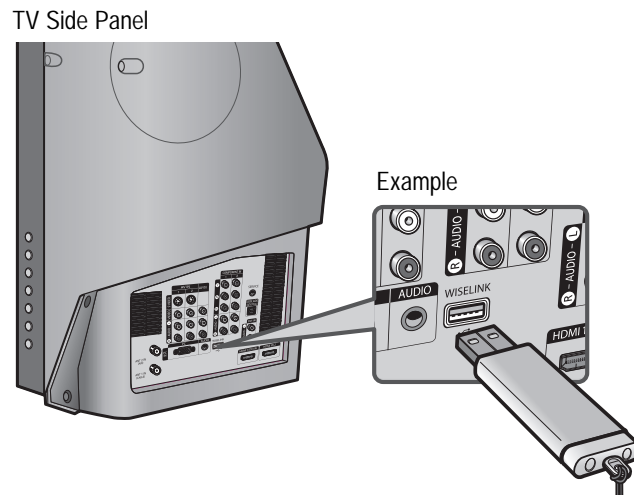

1. Prepare the USB memory stick with the built-in firmware.
2. Select Cable channel 3, and press "Mute" → "7" → "8" → "9" → "Exit" buttons.
3. When the downloading window appears, insert the USB stick to the wiselink port on the side of the TV.
4. TV goes off and turns back on when the download is automatically complete. Remove USB stick to complete the upgrade.

※ Check for the Firmware Version

- 1) Turn off the power to put the unit into the STAND-BY mode.
- 2) In order to enter the Service Mode, Press "Mute" → "1" → "8" → "2" → "POWER" buttons on the Remote Control.
- 3) In case entry into SERVICE MODE is unsuccessful, repeat steps 1 and 2 directly above.
- 4) You can check the firmware version at the bottom of the Factory menu.

T-EINLUS0-XXXX
T-EINLUS5-XXXX
ACL xx.xx.xx
RFS....
20xx-xx-xx
T-LEEUM-xxxx

3-6 Replacements & Calibration

3-6-1 Tilt the Screen

1. Remove the 8 point screws. Remove the Bottom cover. The back cover has to be pulled to the right before being pulled backwards, due to the AIR FLOW guide gets caught on the CHASSIS FRAME. Fix the safety switch on the right with tape so that the set can be turned on after removing the bottom cover.

: BH,+B,M4,L12,ZPC(BLK),SWRCH18



2. After Remove the 2 point screws, pull out the optical engine. Remove 1 point screw in the Fan assy. And the turn counterclockwise fan assy.

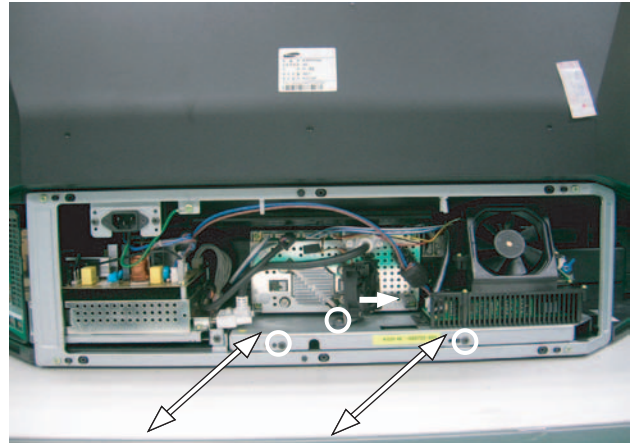

3. Remove 3 point screw covers. And then loose the 3 points screws.

* Left 2 points screws

: PWH,S,M3,L8,ZPC(YEL),SWRCH18A

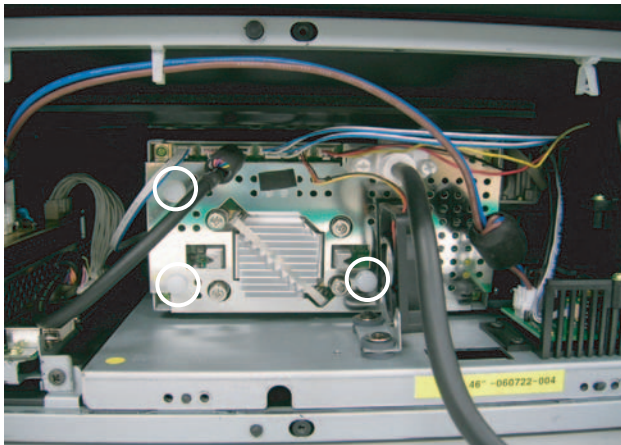

4. Turn off the power to put the unit into the STAND-BY mode.

In order to enter the Service Mode, Press "Mute" → "1" → "8" → "2" → "POWER" button on the Remote Control. Select DDP3021 of the Service Mode menu. Press the ▲ ▼ (Up or Down) button to move to TEST PATTERN, then press ENTER to select. Press the ► (Right) button until you see CROSSHATCH PATTERN. Then, adjust the screen position, by holding both of the upper corners of the DMD board.

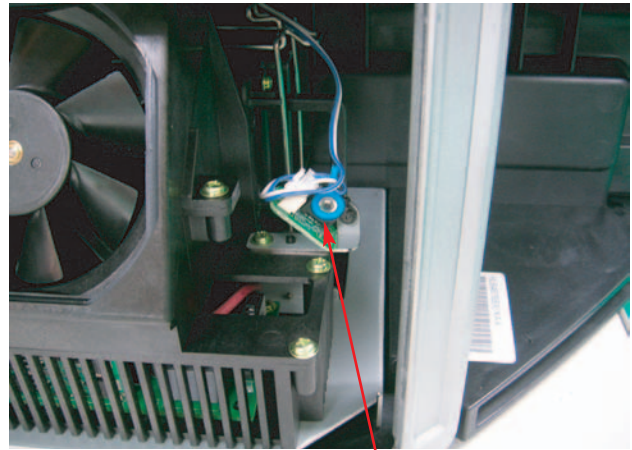
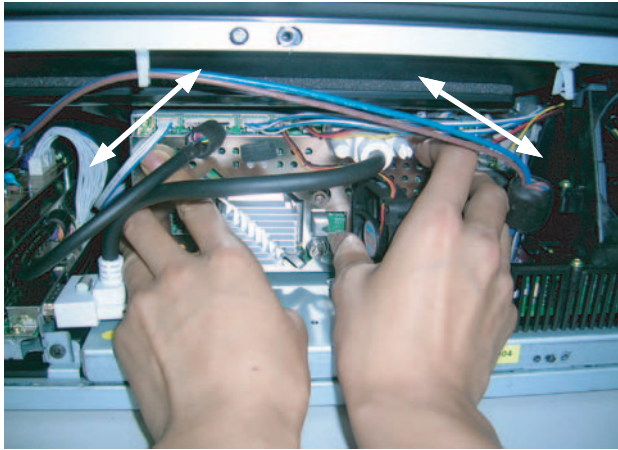

CROSSHATCH PATTERN

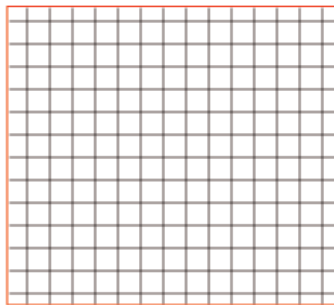

Fix the safety switch on the right with tape so that the set can be turned on after removing the bottom cover.

- ※ Even when those screws are removed, the board does not separate it can be moved within the adjustable range because there is a spring screw at the center that holds it.
- ※ When adjusting the screen, it is better for two people to work together.
One person should adjust the picture position while the other person looks at the screen.
- ※ The movement direction of the board and the picture are opposite.
 - When the board is lifted upward, the screen descends down.
 - When it is tilted to the left, the screen tilts to the right.
- ※ When the picture adjustment is completed:
First, tighten the two screws on the left of the DMD board and then slowly tighten the one screw on the bottom right.
Be careful not to touch the board while tightening the screws.
(When using an electric-powered screwdriver, be careful that the torque is not too high.)
- ※ When adjusting tilt by yourself, adjust it with setting the mirror in front of the set and watch it.
the other way is referring to the 12-1-11 and separating cover dust and adjusting the screen with looking into the hole.

3-6-2 Align the Focus

1. Remove the bottom cover.

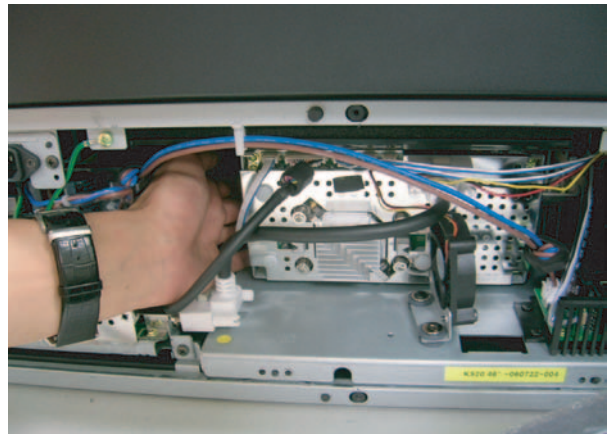

2. It is not necessary to remove the engine assy to make the adjustment.
Insert your hand / finger into the set as shown in the diagram below. Move the focus alignment dial of Projection lens to the clockwise or counter clockwise until the picture is clear displayed.

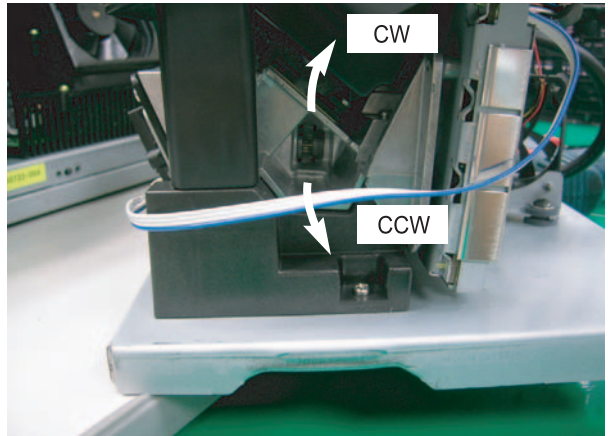
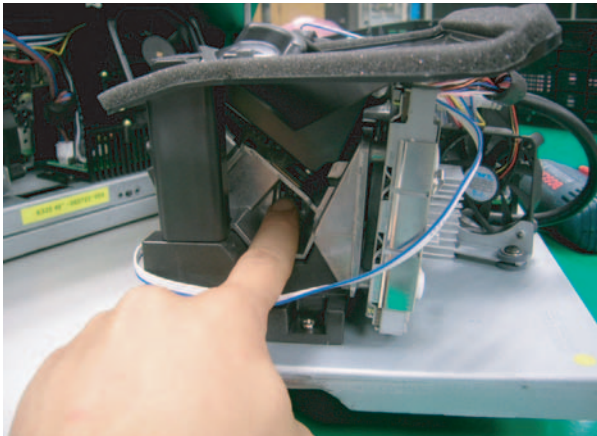

- ※ When adjusting the Focus, it is better for two people to work together. One person should adjust the picture position while the other person looks at the screen.
When adjusting tilt by yourself, adjust it with setting the mirror in front of the set and watch it.
the other way is referring to the 12-1-11 and separating cover dust and adjusting the screen with looking into the hole.

MEMO

4. Exploded View & Part List

4-1 HLS4676SX/XAA

You can search for the updated part code through ITSELF web site.
 URL: <http://itself.sec.samsung.co.kr>

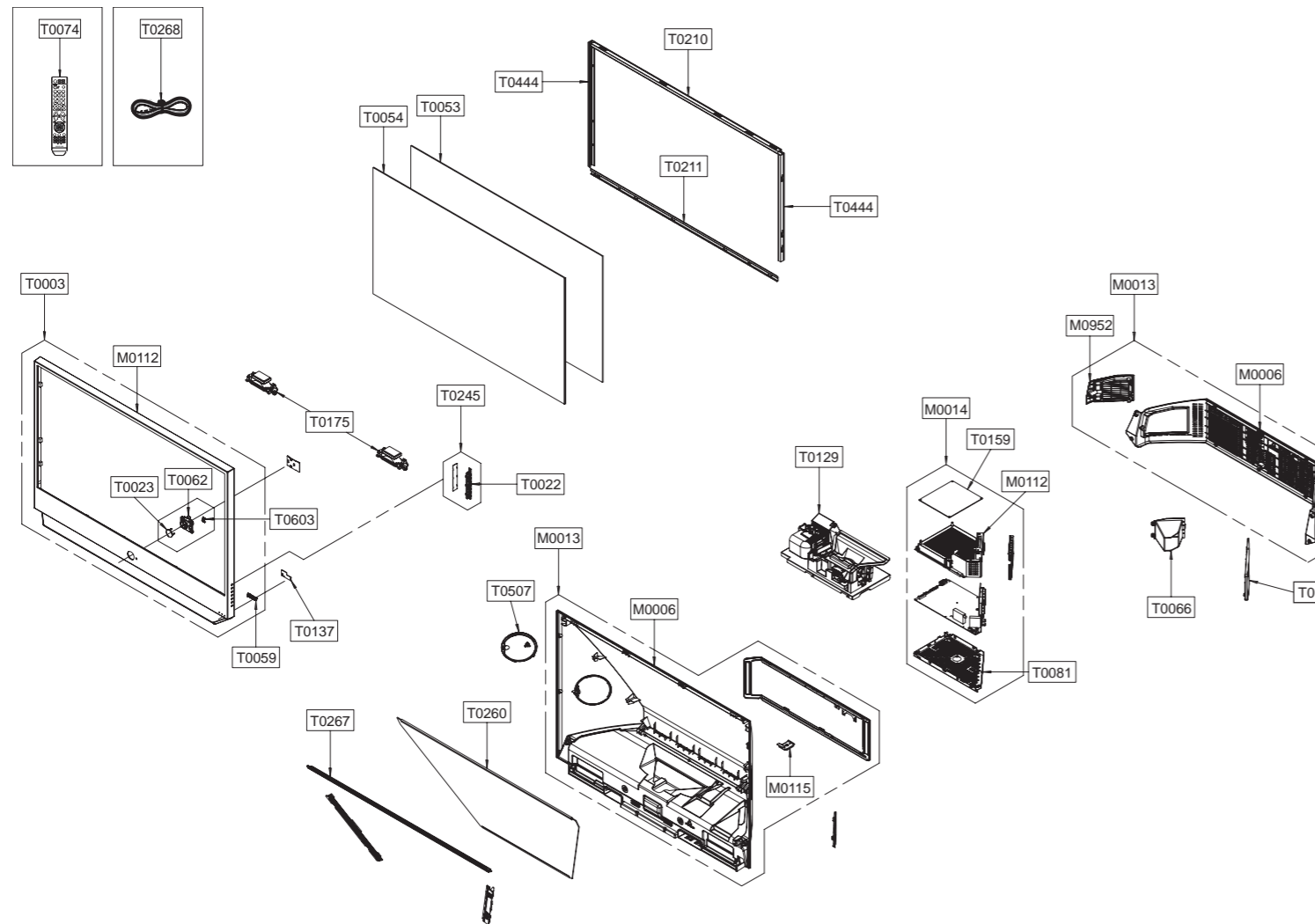

Loc.No.	Code No.	Description	Specification	Q'ty	SA/SNA	Remark
M0006	BP63-00830A	COVER-REAR	46K5(SLIM),PS,V0,BK500,NON-DE	1	S.N.A	
M0006	BP63-00831A	COVER-REAR BOTTOM	46K5(SLIM),PS,V0,BK500	1	S.N.A	
M0013	BP96-01643A	ASSY COVER P-REAR	46K5,HIPS,V0,BK500,NON	1	S.A	
M0013	BP96-01644A	ASSY COVER P-REAR BOTTOM	46K5,HIPS,V0,BK	1	S.A	
M0014	BP94-02291A	ASSY PCB MAIN	HLS4676,L64C,IRIS	1	S.A	
M0112	BP63-00829A	COVER-FRONT	46K5(SLIM),ABS+PMMA,HB,BK23,	1	S.N.A	
M0112	BP96-01661B	ASSY SHIELD P-PCB	46K5,SECC,T0.5	1	S.N.A	
M0115	BP61-01324A	BRACKET-STAND	46K5(SLIM),SECC,T2.0	1	S.N.A	
M0952	BP63-00833A	COVER-DUCT	46K5(SLIM),ABS,V0,BK500,RTI 9	1	S.N.A	
T0003	BP96-01642A	ASSY COVER P-FRONT	46K5,SEA,ABS+PMMA,HB,	1	S.A	
T0022	BP64-00610A	KNOB-CONTROL	46K5(SLIM),ABS,HB,BK500,AL	1	S.N.A	
T0023	BP64-00612A	KNOB POWER	46K5(SLIM),PC,VIOLET	1	S.N.A	
T0053	BP67-00278A	SCREEN FRESNEL	K520,46W 1034mmx590mm,1.5	1	S.A	
T0054	BP67-00277A	SCREEN LENTI	K520,46W 1034mmx590mm,2.1T,	1	S.A	
T0059	BP64-00611A	INDICATOR LED	46K5(SLIM),PC,CLEAR	1	S.N.A	
T0062	BP61-01330A	HOLDER-POWER	46K5(SLIM),ABS,HB,BK500,AL	1	S.N.A	
T0066	BP96-01666A	ASSY COVER P-DUCT	46K5,PC+GF20%,T2.5	1	S.N.A	
T0074	BP59-00107A	REMOCON	Einstein,TM87B,54,NTSC,L64D	1	S.A	
T0081	BP61-01327A	BRACKET-MAIN	46K5(SLIM),SECC,T0.8	1	S.N.A	
T0129	BP96-01652A	ASSY ENGINE P-DLP	46K5,K520,PHILIPS,132W	1	S.A	
T0130	BP96-01645A	ASSY COVER P-TERMINAL BOARD	IRIS(46K5),S	1	S.N.A	
T0137	BP94-02292A	ASSY PCB MISC-LED	IRIS	1	S.A	
T0159	BP96-01650A	ASSY PCB P-SMPS	HLS-4676SX,L64E,AC120V,1	1	S.A	
T0175	BP96-01635A	ASSY SPEAKER P	8ohm,Horn,10W,SLIM DLP,K5	1	S.A	
T0210	BP61-01335A	BRACKET-SCREEN TOP	46K5(SLIM),AL 6063 EX	1	S.N.A	
T0211	BP61-01328A	BRACKET-SCREEN BOTTOM	46K5(SLIM),AL 6063	1	S.N.A	
T0245	BP94-02285A	ASSY PCB MISC-KEY CONTROL	IRIS	1	S.A	
T0260	BP67-00294A	MIRROR-FRONT	46K5,Glass,964 μ 494 μ 541 μ (1	S.A	
T0267	BP61-01334B	BRACKET-MIRROR TOP	46K5(SLIM),AL 6063 EX	1	S.N.A	
T0268	3903-000144	CBF-POWER CORD	DT,US,BP3/Y,U(IEC C13-RA)	1	S.A	
T0444	BP96-01648A	ASSY BRACKET P-SCREEN SIDE	46K5,AL6063,E	1	S.N.A	
T0444	BP96-01649A	ASSY BRACKET P-SCREEN SIDE	46K5,AL6063,E	1	S.N.A	
T0507	BP63-00832A	COVER-DUST	46K5(SLIM),PS,HB,BK500	2	S.N.A	
T0603	BP64-00613A	WINDOW-RMC	46K5(SLIM),PC,VIOLET	1	S.N.A	

5. Electrical Part List

5-1 HLS4676SX/XAA Service Item

You can search for the updated part code through ITSELF web site.

URL:<http://itself.sec.samsung.co.kr>

Loc.No.	Code No.	Description	Specification	Q'ty	SA/SNA	Remark
M0013	BP96-01643A	ASSY COVER P-REAR	46K5,HIPS,V0,BK500,NON	1	S.A	
M0013	BP96-01644A	ASSY COVER P-REAR BOTTOM	46K5,HIPS,V0,BK	1	S.A	
M0014	BP94-02291A	ASSY PCB MAIN	HLS4676,L64C,IRIS	1	S.A	
M0125	BP39-00106C	CBF SIGNAL-DVI(D)	HLP5063WX,24P/24P,2027	1	S.A	
M2893	BN39-00640C	LEAD CONNECTOR	HLS5686W,UL1007#26,UL/CSA	1	S.A	
M2893	BP39-00141C	LEAD CONNECTOR	HLS6187WX/XAA,UL1617#22,U	1	S.A	
M2893	BP39-00174G	LEAD CONNECTOR	HLS4676SX/XAA,UL1007#22,U	1	S.A	
M2893	BP39-00180D	LEAD CONNECTOR	HLS4676SX/XAA,UL1015#18,U	1	S.A	
M2893	BP39-00192C	LEAD CONNECTOR	IRIS,UL2464#26,UL/CSA,12p	1	S.A	
M2893	BP39-00204B	LEAD CONNECTOR	HLS4676SX/XAA,UL1061#28,U	1	S.A	
M2893	BP39-00219C	LEAD CONNECTOR	HLS4676SX/XAA,UL2547#26,U	1	S.A	
M2893	BP39-00231C	LEAD CONNECTOR	IRIS,UL1571#30,UL/CSA,5PI	1	S.A	
M2893	BP39-00245A	LEAD CONNECTOR	HLS5686W,UL3443#28,UL/CSA	1	S.A	
M2893	BP39-00246A	LEAD CONNECTOR	IRIS,UL1007#26,UL/CSA,6/2	1	S.A	
T0003	BP96-01642A	ASSY COVER P-FRONT	46K5,SEA,ABS+PMMA,HB,	1	S.A	
T0049	BP47-00033A	LAMP-BALLAST	EUC 132D P/41,160 MM CABLE,	1	S.A	
T0053	BP67-00278A	SCREEN FRESNEL	K520,46W 1034mmx590mm,1.5	1	S.A	
T0054	BP67-00277A	SCREEN LENTI	K520,46W 1034mmx590mm,2.1T,	1	S.A	
T0074	BP59-00107A	REMOCON	Einstein,TM87B,54,NTSC,L64D	1	S.A	
T0129	BP96-01652A	ASSY ENGINE P-DLP	46K5,K520,PHILIPS,132W	1	S.A	
T0159	BP96-01650A	ASSY PCB P-SMPS	HLS-4676SX,L64E,AC120V,1	1	S.A	
T0175	BP96-01635A	ASSY SPEAKER P	8ohm,Horn,10W,SLIM DLP,K5	1	S.A	

MEMO

6. Troubleshooting

6-1 Checkpoints by Error Mode

- 1. Power Light: Check the master switch (ON/OFF) and the fuse to see if they are operating.
- 2. LED Blinking: See the basic LED checklist in 6-2-1

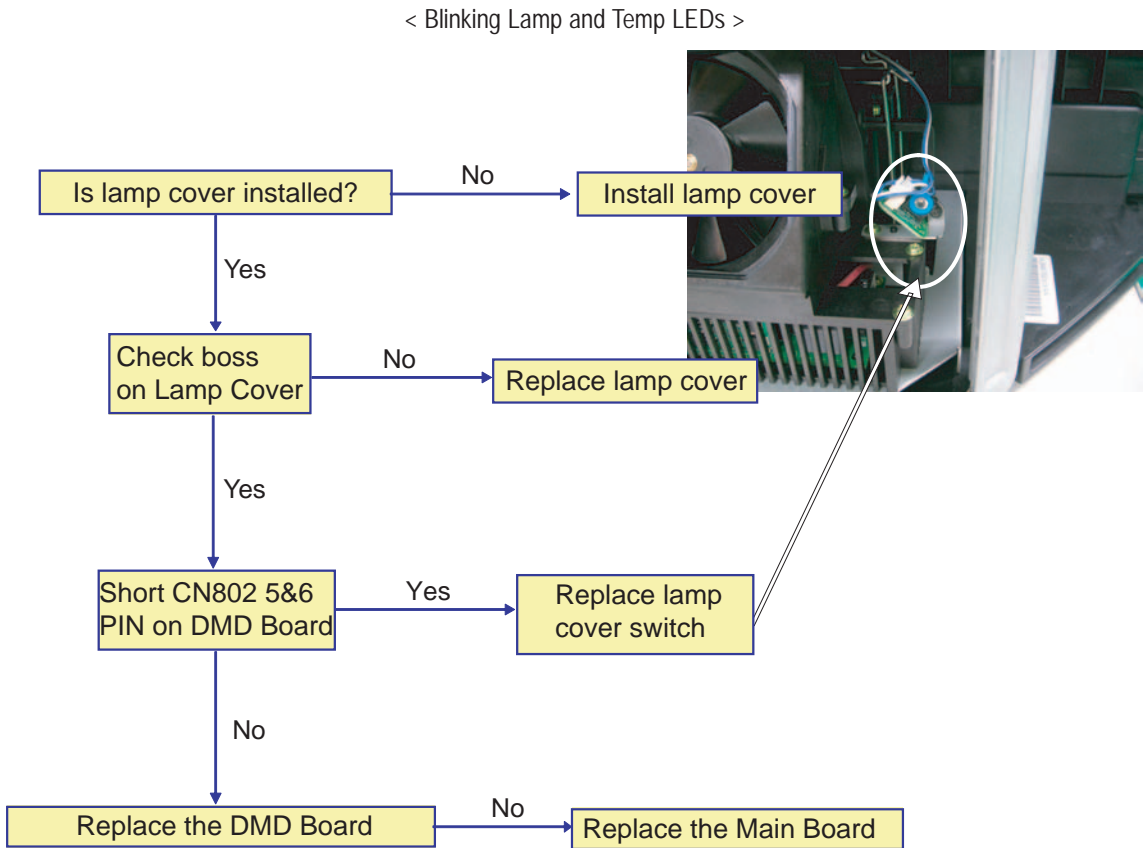
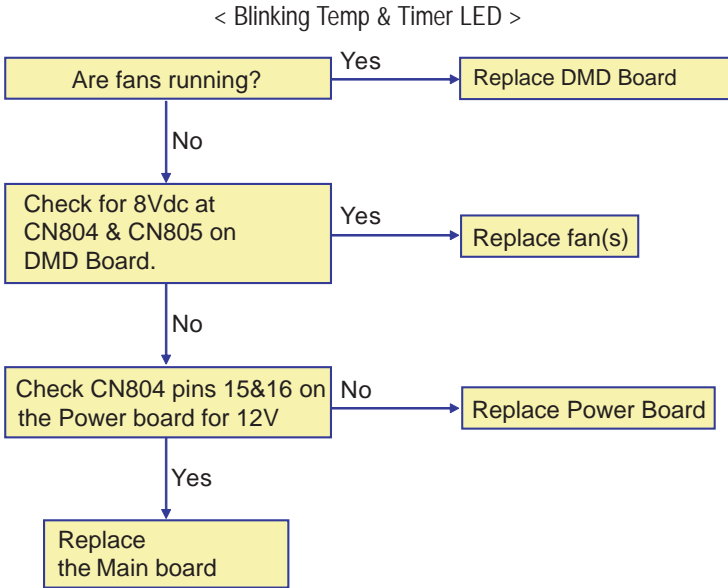

< Blinking Temp LED >

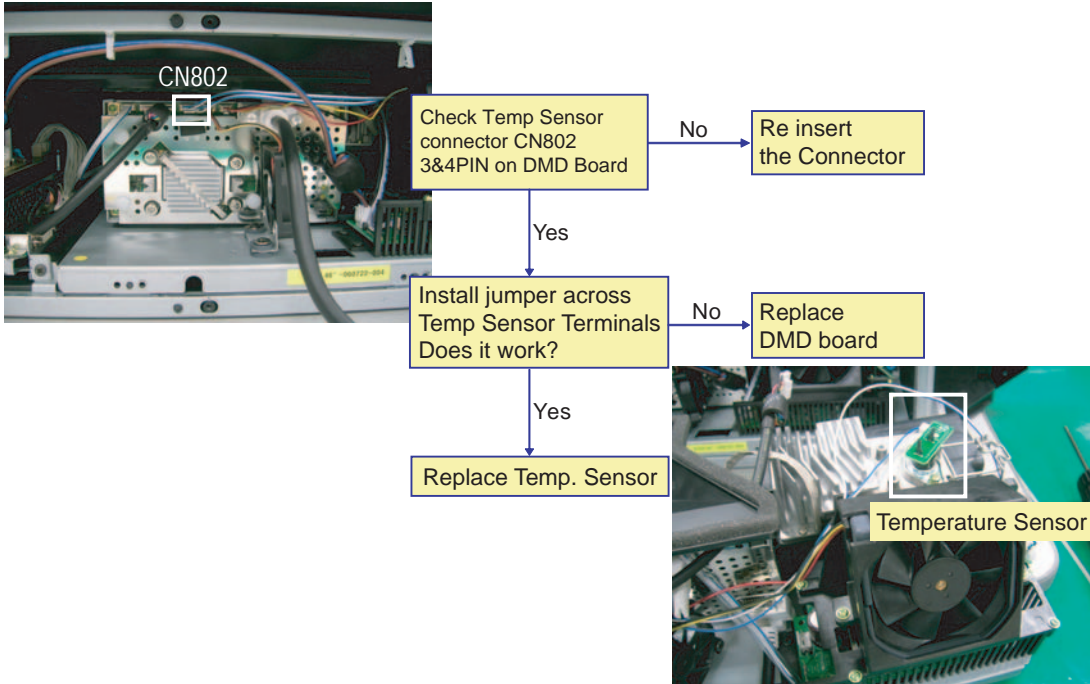

A blinking lamp LED is the most common failure indication. It can be caused by no lamp, no color wheel, no fan(s), or other defective components.

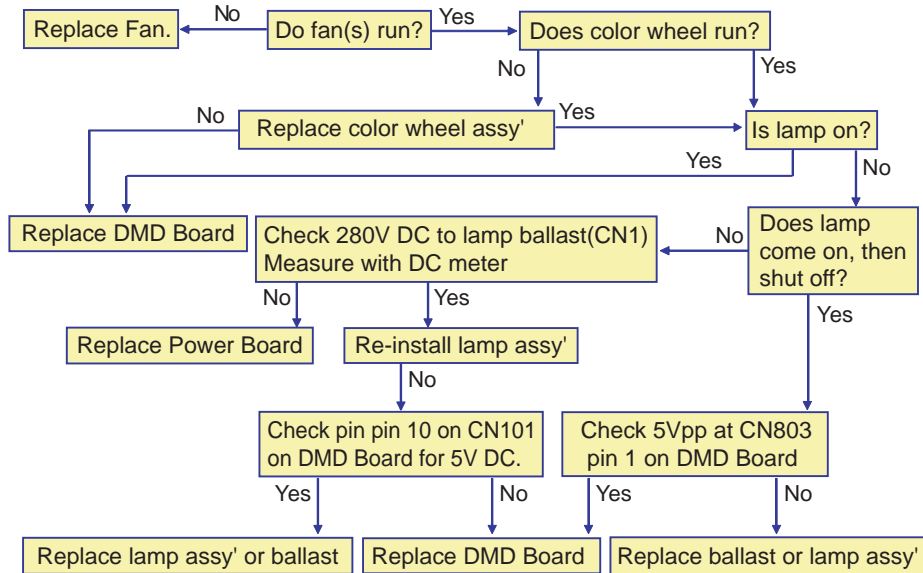

3. Noise:

Internal noise may be caused by a foreign substance on the fan or driving device.

For a DLP TV, the lamp fan, DMD board fan and color wheel are vulnerable to noise. Sometimes the connector wire around the lamp or DMD fan makes contact with the fan, while the color wheel is protected inside the module and cannot make contact with any nearby wires. However the color wheel sensor or the drive motor may cause noise by making contact with the color wheel.

As the color wheel uses an air bearing system, it has a very slight possibility of creating internal noise.

When irregular noise occurs for no particular reason, check the inside of the TV for any foreign substances.

The DLP projection TV may cause noise as the physical screen is empty inside, causing a resonance to a particular frequency.

Thus a low vibration is not a malfunction.

Any 'creaking' noise is mostly from the structure of the device itself. A short, harsh noise may occur from a distortion or malformation due to thermal expansion between the metal joints, screws and loaded parts, respectively. Any intermittent 'creaking' noise can be removed by loosening the screws.

4. Black Screen (Voice Output): Replace the DMD board

5. A black screen with the lamp on: Replace the DMD board.

6. Line Pattern: Regular line patterns occur vertically or horizontally: Replace the DMD board.

7. Voice Distortion: Replace the main board.

8. Outside Light: This is not a product malfunction, but a possible installation or human error. This occurs when the projected light from the surrounding illumination reflects onto the screen. This disappears as the TV starts operating and the TV lamp gets brighter. However, you can avoid outside light by changing the position of the TV or the installation angle.

Decreasing the illumination or changing the indoor lighting may work.

9. Screen Flip-over:

Enter Factory mode in DDP3021 and perform H-Flip (flip horizontally) and V-Flip (flip vertically).

The screen will flip over horizontally or vertically.

10. Other Screen Errors:



- ▶ 40 Vertical lines 16 pixels wide:
DDP3021 or BGA, DMD panel interference.
→ Replace the DMD board

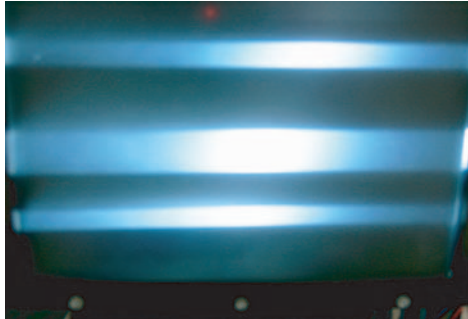

- ▶ Horizontal Bar or No Raster:
Error in DDP3021 or the DMD panel.
→ Replace the DMD board



- ▶ Dotted Vertical Bar:
Error in Rambus Dram(IC301) or the soldering
→ Replace the DMD board

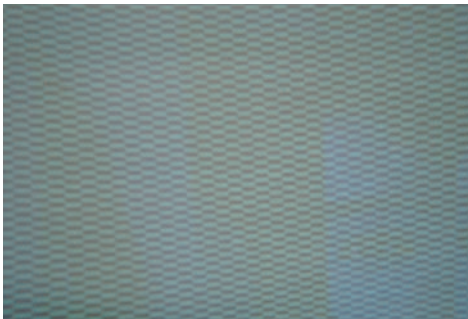

- ▶ Beehive mosaic patterns all over the screen:
Error in the LVDS Receiver (IC100) or the soldering
The H sync signals are not transferred to DDP3021.
→ Replace the DMD board.

6-1-1 Video Circuit Error Checking

■ Basics:

- The DDP3021 on the DMD board has a feature to display internal test patterns.
- DNle, which is an end port in the main board, has a feature to display internal test patterns.
- The X240H is the first output and the DNle output is the second one, followed by DMD, which is the final one.
- The video path flow : RF/External input→X240→ DNle→ DDP3021.

■ Diagnosis By Module

1. Access Service Mode

(In Standby mode, press "Mute", "1", "8", "2" and "Power" to turn the screen on and enter service mode)

2. Check if there is an error in the DMD board

DDP3021 → TEST PATTERN → Press the right arrow key:

Options of FULL WHITE, BLACK, RED, GREEN and BLUE PATTERN and so on are displayed on the screen.

If "Pattern" does not appear, this is a DMD board error.

3. Check if there is an error in the Main board

Factory mode→ DNle→TEST PATTERN→ Press the right arrow key

If "pattern" does not appear, this is a Main board error. Replace Main board.

4. Check if there is an error in the main board.

Check for a power signal from SMPS to other board see the schematic diagram(10-1) And check for indicated power signal.

6-1-2 Flow Chart for Malfunction

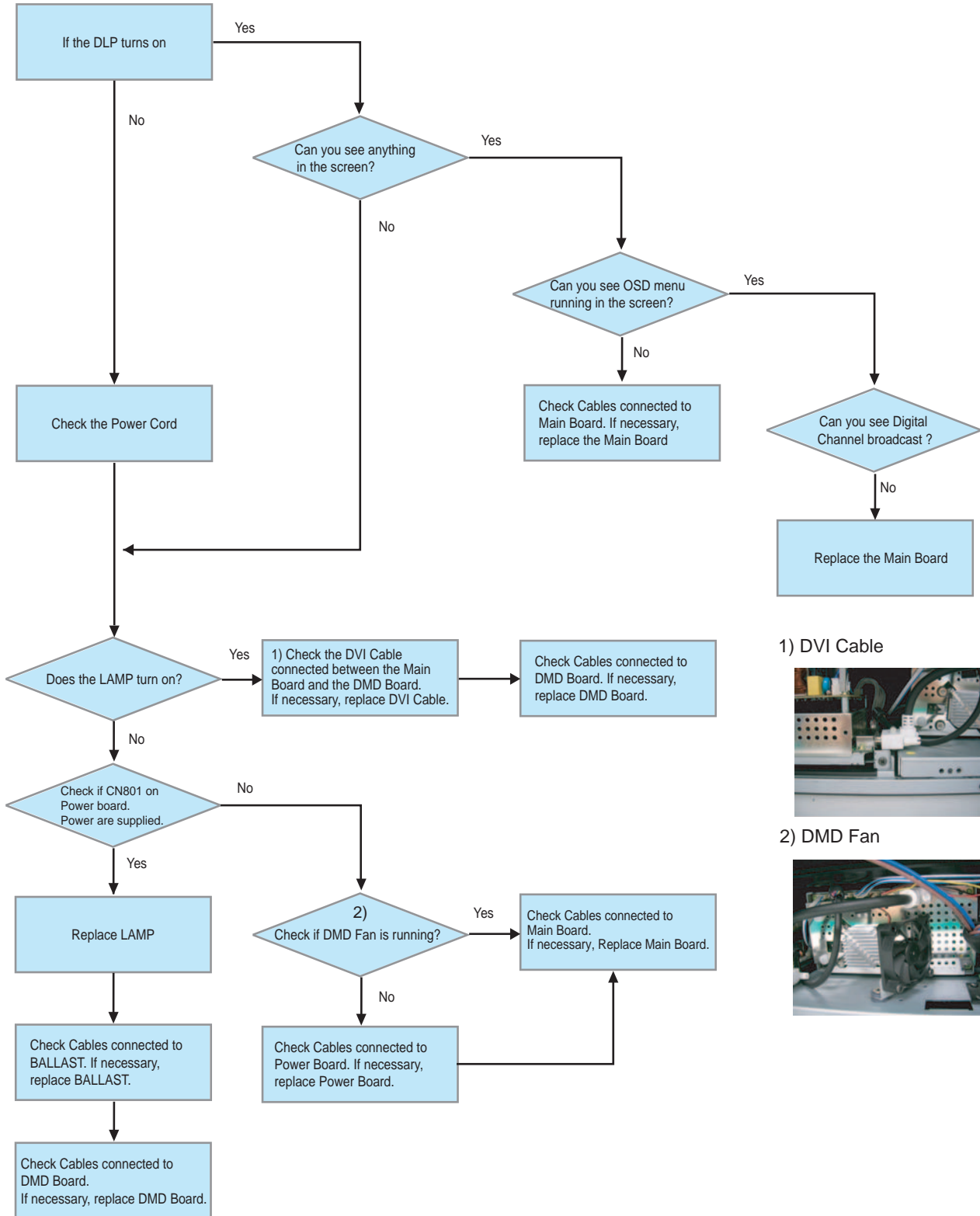

1) DVI Cable

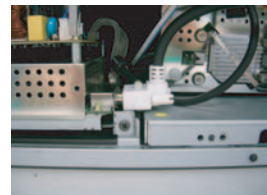

2) DMD Fan

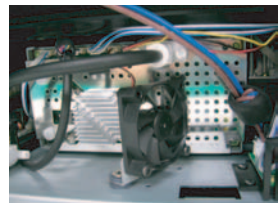

6-2 Troubleshooting Procedures by Error Modes

6-2-1 Installation & Connection

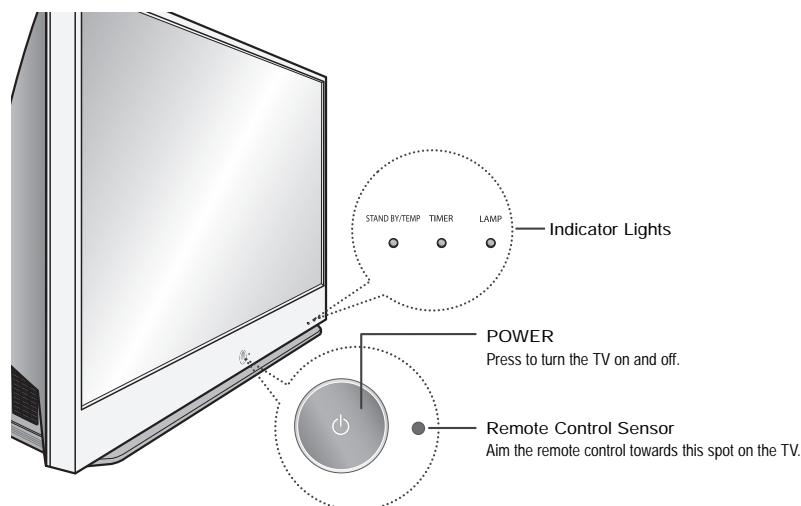

- : Light is On
- ◐ : Light is Blinking
- : Light is Off

TIMER	LAMP	STAND BY/TEMP	Indication
○	○	●	Standby state.
○	◐	○	The picture will automatically appear in about 15 seconds.
●	◐	○	Auto Timer ON/OFF has been set and the set will automatically be turned on in about 25 seconds.
◐	○	◐	A cooling fan inside the set is not operating normally.
○	◐	◐	Lamp cover on rear of the set is not properly shut.
○	○	◐	Check if the ventilation hole on the rear of the set is blocked, because if the inner temperature is too high, the power will shut off.
◐	◐	◐	Lamp may be defective. Please contact a certified technician.

- * It takes about 30 seconds for the TV to warm up, so normal brightness may not appear immediately.
- * The TV has a fan to keep the inside lamp from overheating. You'll occasionally hear it working.

6-2-2 Protect Status

1. When the rear cover is opened

A sensor detects when the rear cover is opened and turns the set off and then into Standby mode.

If you close the cover or fix the switch, you can turn the set on by pressing the Power button on the unit or the remote control. The set will then operate normally.

2. When the temperature sensor operates

When the set is overheated, the internal temperature sensor turns the set off and the set goes to Standby mode.

When the internal temperature of the set returns to a normal range, turn the power on by pressing the Power button on the unit or the remote control. The set will then operate normally.

3. Attempting to turn the lamp on fails repeatedly

If turning the lamp on fails, the set automatically tries turning the lamp on 3 times. If all attempts fail, all LED's on the front panel will blink. Check the lamp and the ballast and replace them, if necessary.

6-3 Troubleshooting Procedures by ASS'Y

6-3-1 Check Lamp & Ballast

1. When the lamp is not on, check if there is anything wrong with the ballast.

Remove the lamp(refer to 12chapter). Fix the safety switch on the right with tape and turn on the power. Check to see if a blue flame starts igniting in the arc gap inside the ballast momentarily during start-up. There is no problem with the ballast if there is a flame. When the ballast has no error, replace the lamp.

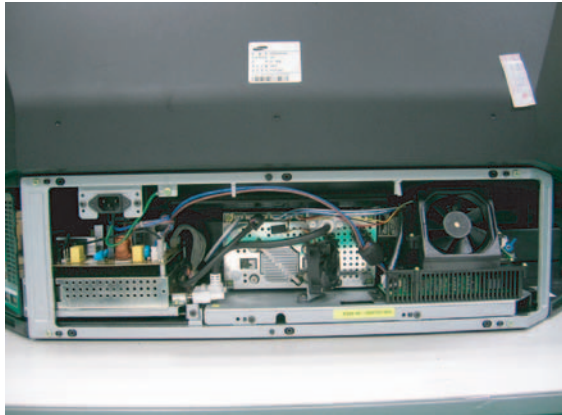

A blue flame occurs momentarily during start-up.

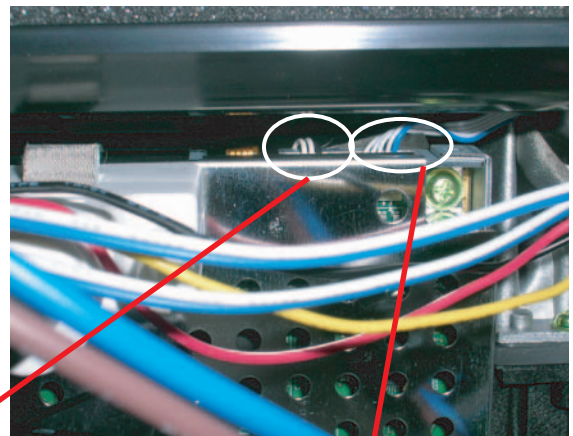
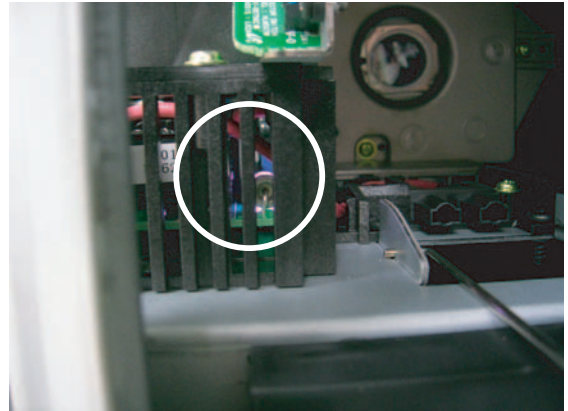

3.5V 240Hz

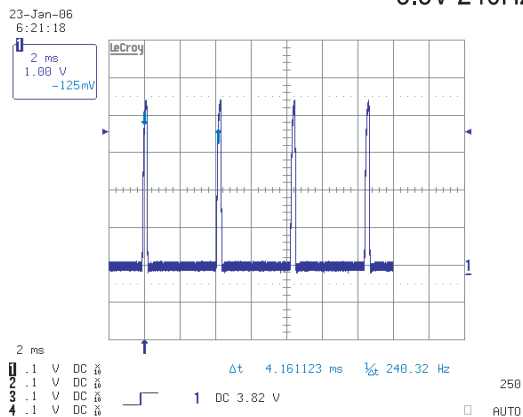

5V 120Hz

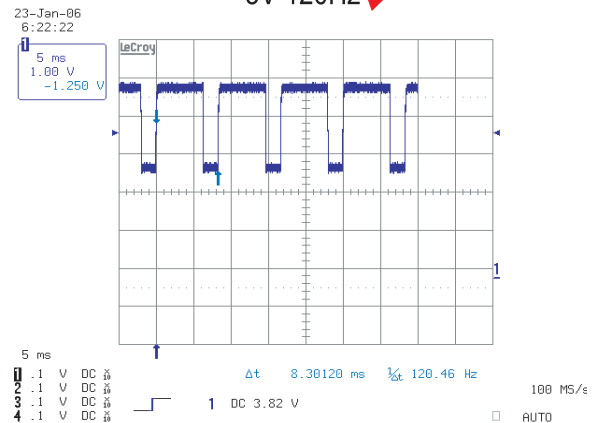

6-3-2 When the lamp and the ballast are normal but the lamp does not turn on or turns off right after quickly lighting up

1. Check the color wheel
 - Check if the color wheel is running. + Check the DMD board and the ballast for the signals.
 - Check the second CN800 pin for input signals. When 3.5V, 240Hz is output, the color wheel is operating normally.

COLOR WHEEL SENSOR DETECTION

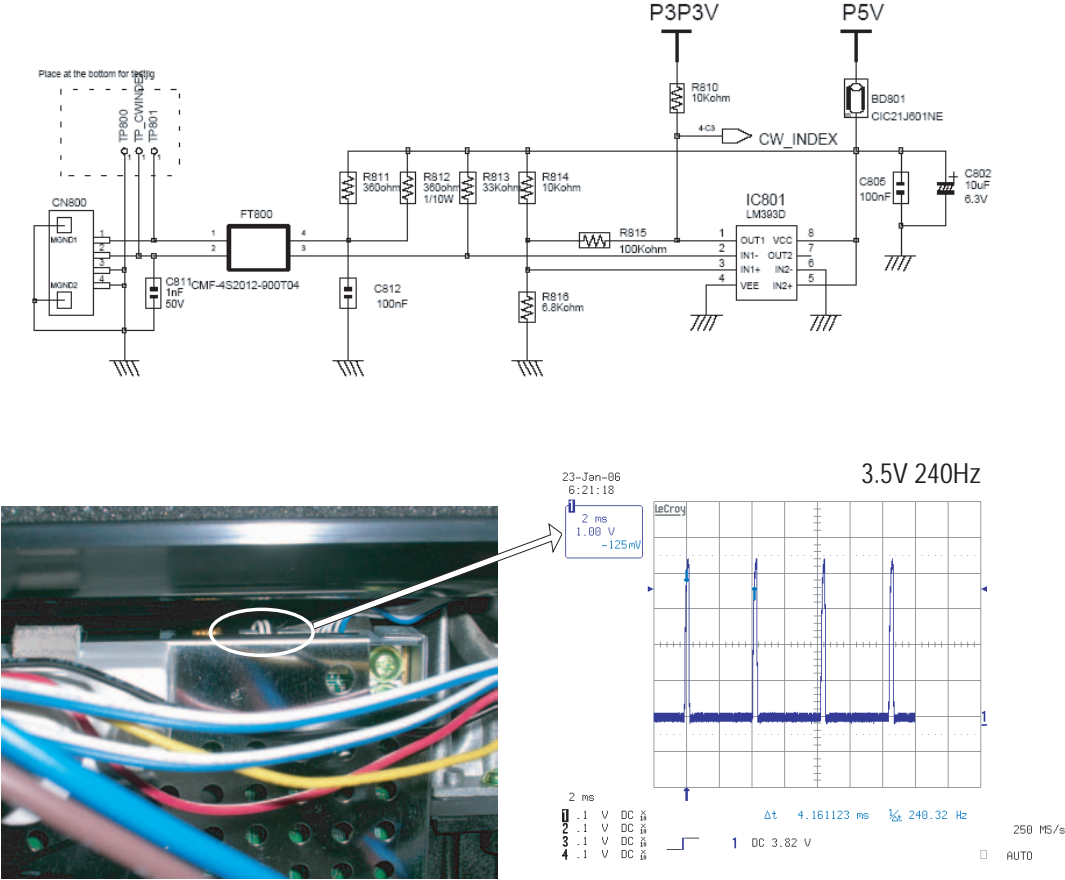

※ DMD Board Check Diagram

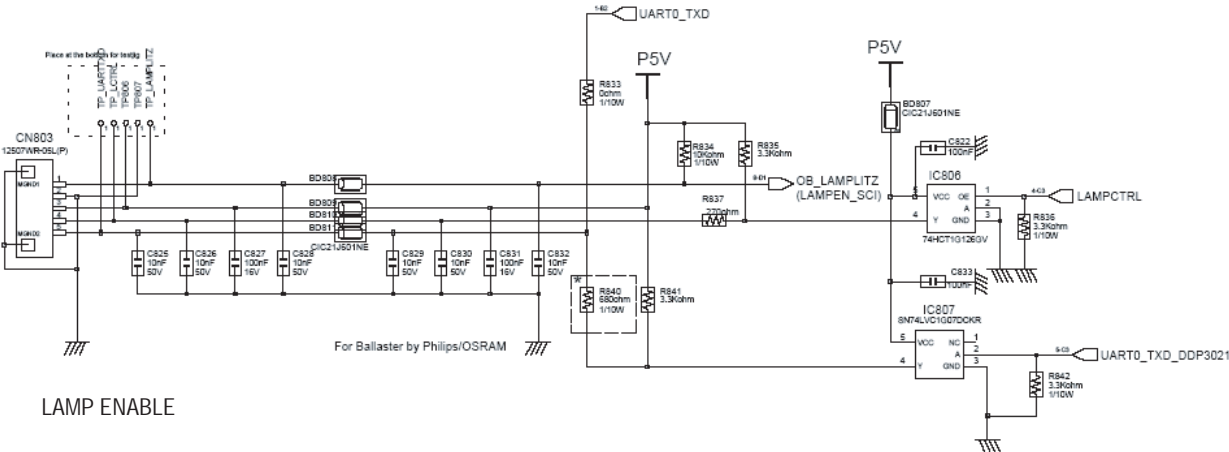

MEMO

7. Block Diagram

7-1 Overall Block Diagram

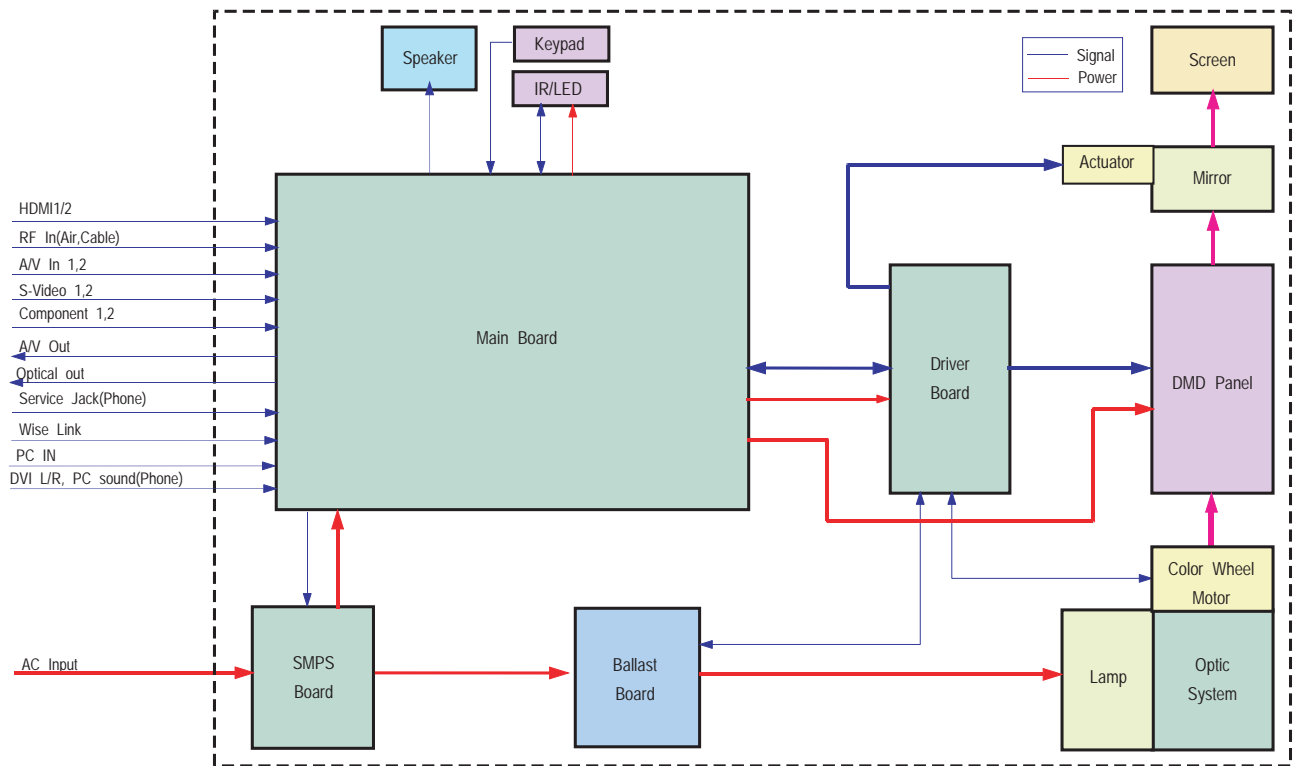

7-2 Partial Block Diagram

7-2-1 SMPS Block Diagram

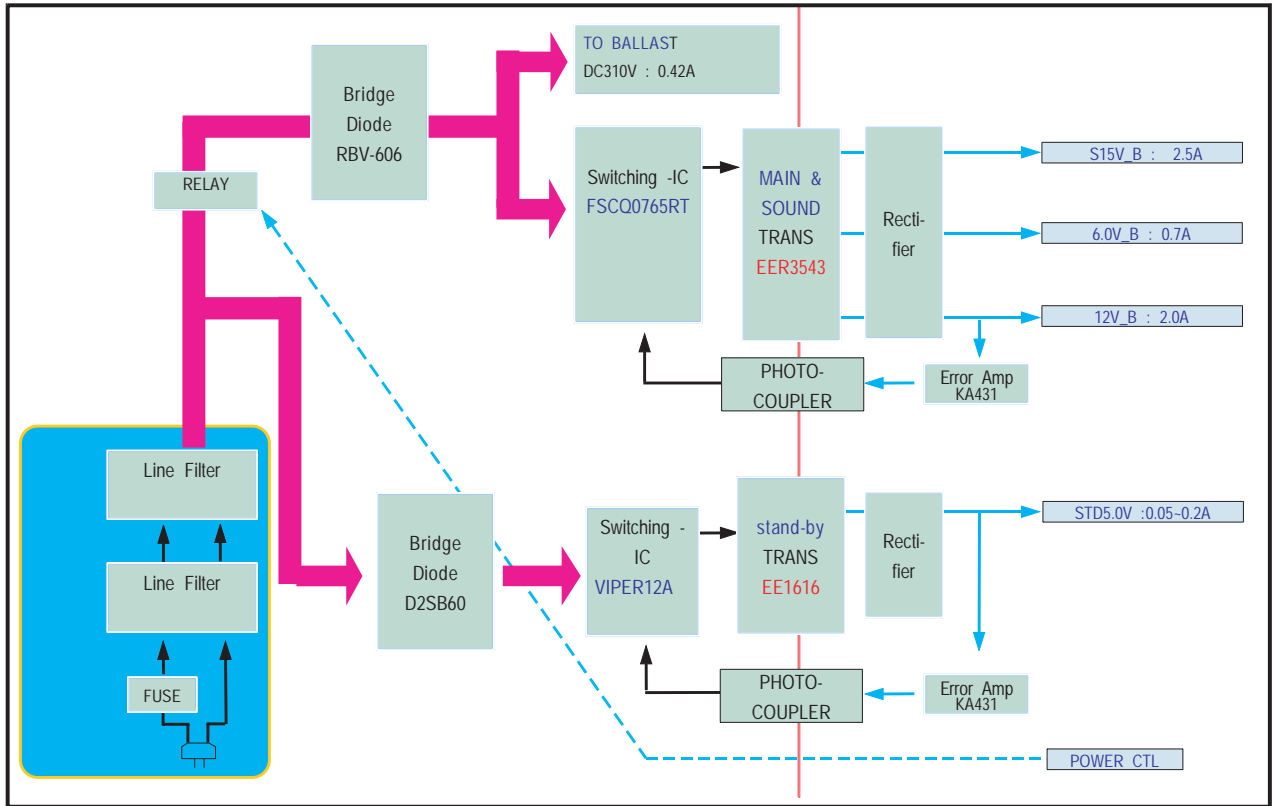

7-2-2 Digital Block Diagram

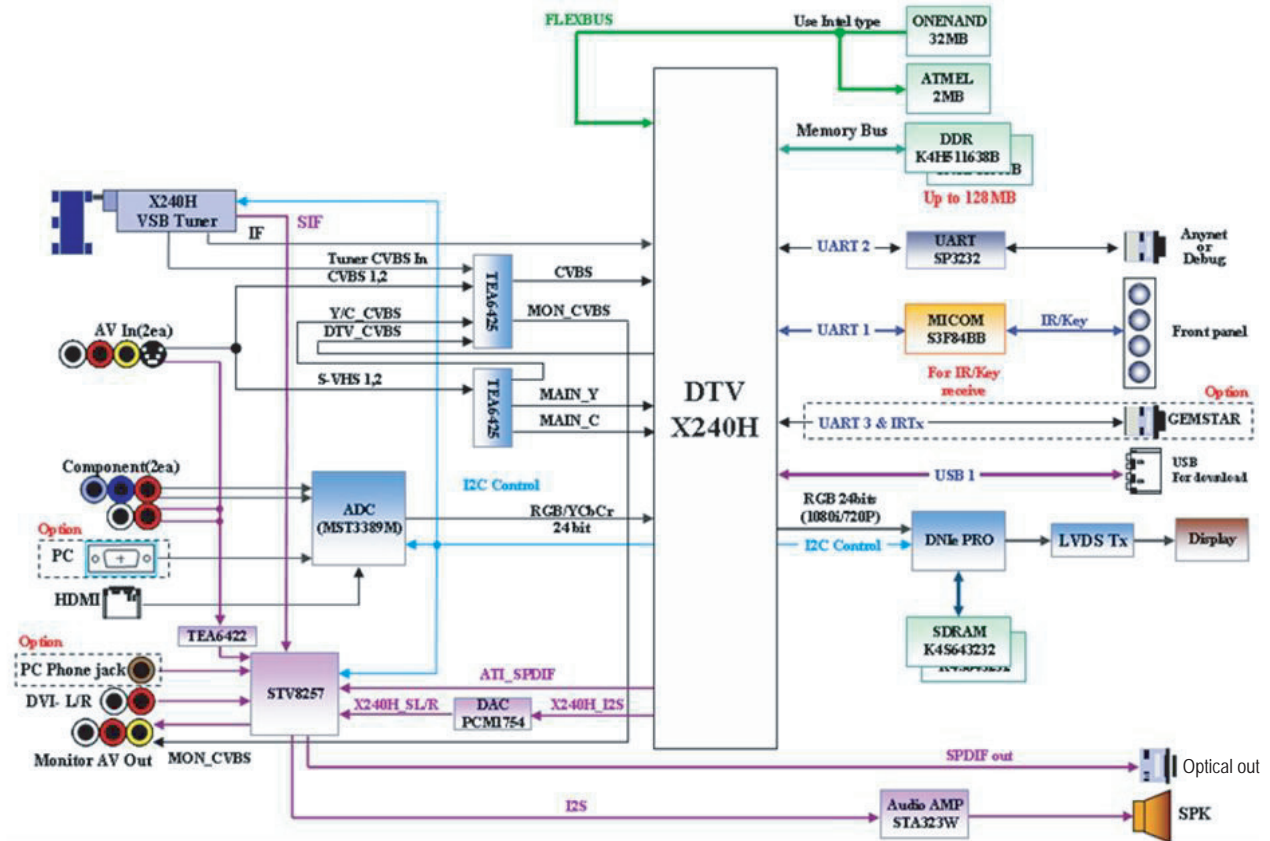

7-2-3 DMD Block Diagram

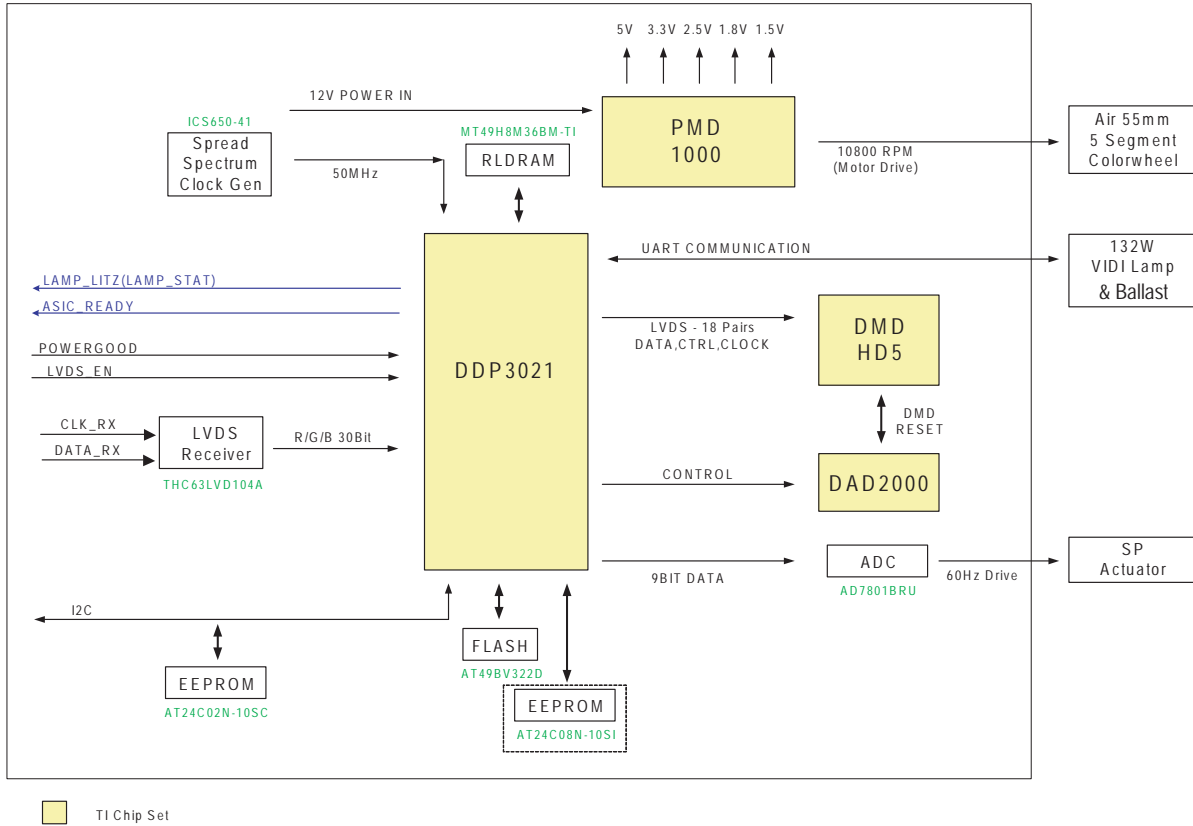

8. Wiring Diagram

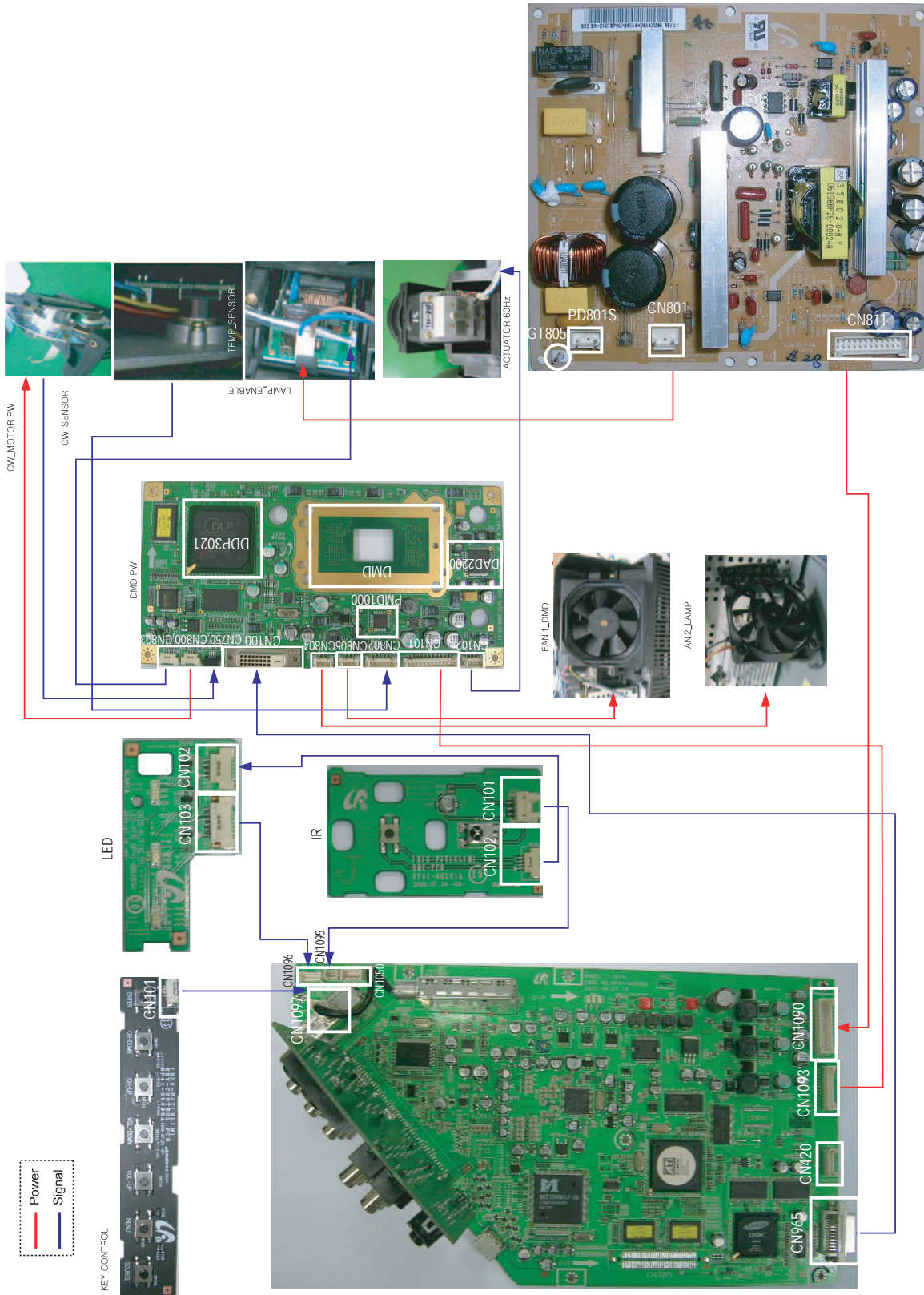

8-1 Overall Wiring

8-1-1 Overall Wiring



8-1-2 Connect Cables

※ The code number of cable(Lead-connector) can be changed, see "5. Electrical Part List."

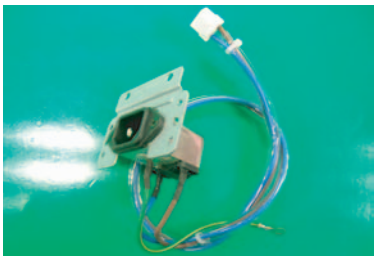
Use	Actuator_SP	DVI (300mm : K520)	Inlet
Code	BN39-00640C	BP39-00230A	BP96-00972F
Photo			

8-2 Connector of Main Board

CN1040

1	2	3	4	5	6	7	8	9	10	11	12	13	14	15	16	17	18	19	20	21	22	23	
STB_5V	G	33VB	G	POWER-SW	D5.7V	G	12VB	G	12VB	G	12VB	G	12VB	G	12VB	G	12VB	G	12VB	G	12VB	G	70VB
POWER-MUTE	S16VB	G	S16VB	G	S16VB	G	S16VB	G	S16VB	G	S16VB	G	S16VB	G	S16VB	G	S16VB	G	S16VB	G	S16VB	G	S16VB

Front IR
CN1095

1	2	3
IR	G	STB5V

Front KEY
CN1047

1	2	3	4	5	6
STB_5V	KEY-PWR	G	LED-STB	LED_LAMP	LED_TIMER

Side Key
CN1045

1	2	3	4
G	KEY1	KEY2	G

AUDIO
CN1050

1	2	3	4
-L-OUT	+L-OUT	-R-OUT	+R-OUT

Act uat or
CN1043

1	2	3	4	5	6	7	8	9	10
G	12VB	G	SDA-MI	SCL-MI	G	STB_5V	G	70VB	G

CN1010 Flash Download from DDC

1	2	3	4	5	6
STB_3.3V	SDA0	SCL0	TEST	RESETEn	G
_M_COM					



CN111 For M COM debuggi ng

1	2	3	4
G	RxD0	TxD0	STB_3.3V_M_COM

CN156 BUS_STOP for Debug

1	2	3	4	5
SDA_D	SCL_D	G	STB_3.3V_M_COM	BUS_STOP

CN155 BUS_STOP for Debug

1	2	3	4	5
SDA_M	SCL_M	G	STB_3.3V_M_COM	BUS_STOP

CN100 ATI Y-Pb-Pr

1	2	3	4
ATI_PrR	ATI_PbB	ATI_YG	G

8-2-1 Main Board Connector Pin

CN1090

Pin Name	PIN No.		Pin Name
STB-5V	1	2	Power-Mute
G	3	4	S16VB
33VB	5	6	G
G	7	8	S16VB
POWER-SW	9	10	G
D5.7V	11	12	D5.7V
G	13	14	G
12VB	15	16	12VB
G	17	18	G
12VB	19	20	12VB
G	21	22	G
G	23	24	70VB

CN1093

Pin No.	Pin Name
1	G
2	G
3	12V
4	12V
5	G
6	SDA
7	SCL
8	G
9	5V
10	G
11	G
12	G

CN1095

Pin No.	Pin Name
1	IR
2	G
3	STB5V

CN1097

Pin No.	Pin Name
1	G
2	KEY1
3	KEY2
4	G

CN1096

Pin No.	Pin Name
1	STB-5V
2	KEY-PWR
3	G
4	LED-STB
5	LED-LAMP
6	LED-TIMER

CN1050

Pin No.	Pin Name
1	-L-OUT
2	+L-OUT
3	-R-OUT
4	+R-OUT

9. PCB Diagram

9-1 Power Board

9-1-1 Assy Power Board

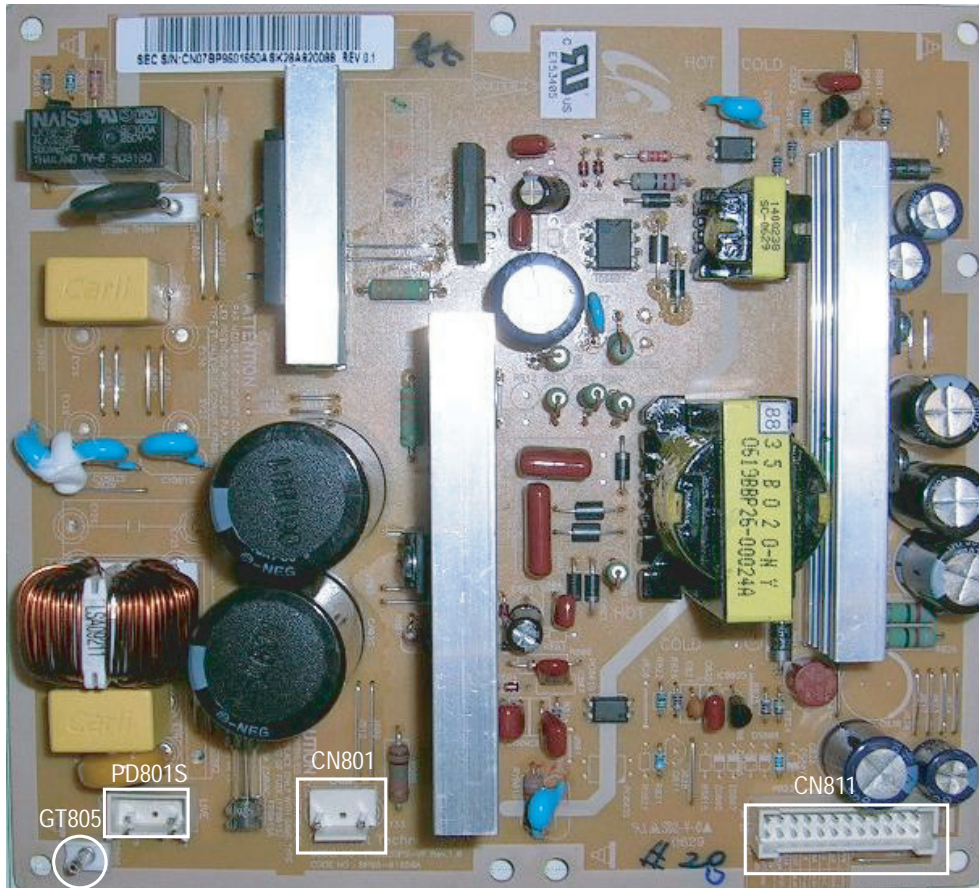

- DC Power Supply
(Supplies DC power to the Main PCB. The analog board is responsible for the power supply to the digital/DMD board.)

9-1-2 Names & Roles of Key Parts

- * CN801 : Supplies power (DC330V \pm 10%) to the ballast.
- * GT805 : Anti-lightning wire connected to the digital board. The anti-lightning wire should be installed for safety purposes.
- * PD801S : Connecting with power cable.
- * CN811 : Supplies power to Main board.

9-2 Main Board

9-2-1 Assy Main Board

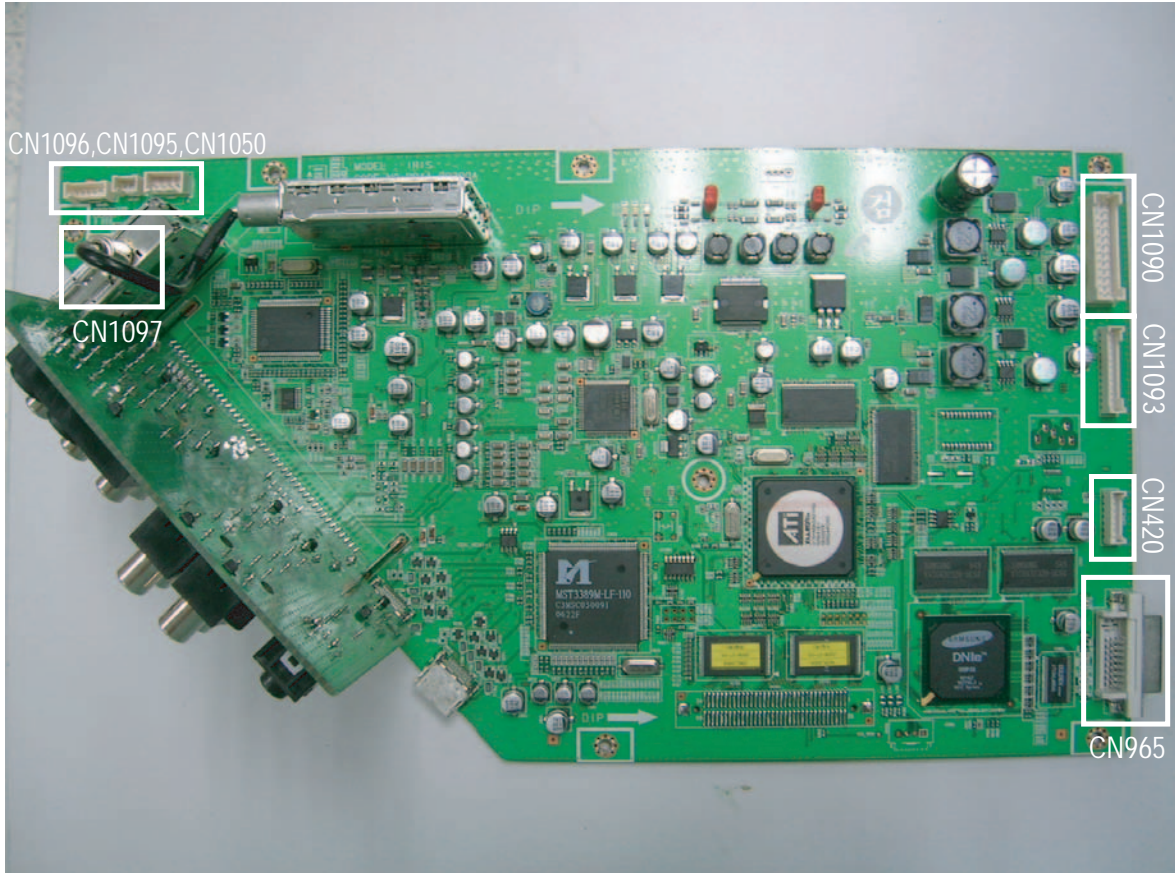

- Microprocessor (Generates turn-on signal to power board)
- All Digital Video Processing
- OSD / Menu
- Reset Switch
- Distributes supply voltage from the Power Board to DMD Board.
- Transfers Turn-on Command to Power Board.
- Analog Video Switching / Processing
- Analog Audio Switching / Processing

9-2-2 Names & Roles of Key Parts

* High Definition Multimedia Interface :

The HDMI™ (High Definition Multimedia Interface) supports uncompressed standard and high definition digital video formats and existing digital multi-channel audio formats.

- * CN1090 : Transfer Power sources from SMPS board.
- * CN1093 : connection with DMD Board. Transfer power signal and I2C signal
- * CN420 : Download Micom Program.
- * CN1050 : Transfer Sound signal to Speaker.
- * CN1095 : Receive IR signal.
- * CN1096 : Transfer Front LED power signal and Power switch signal.
- * CN1097 : Receive Side Key signal.
- * CN965 : Transfer video signal and control signal.

9-3 DMD Board

9-3-1 Assy DMD Board

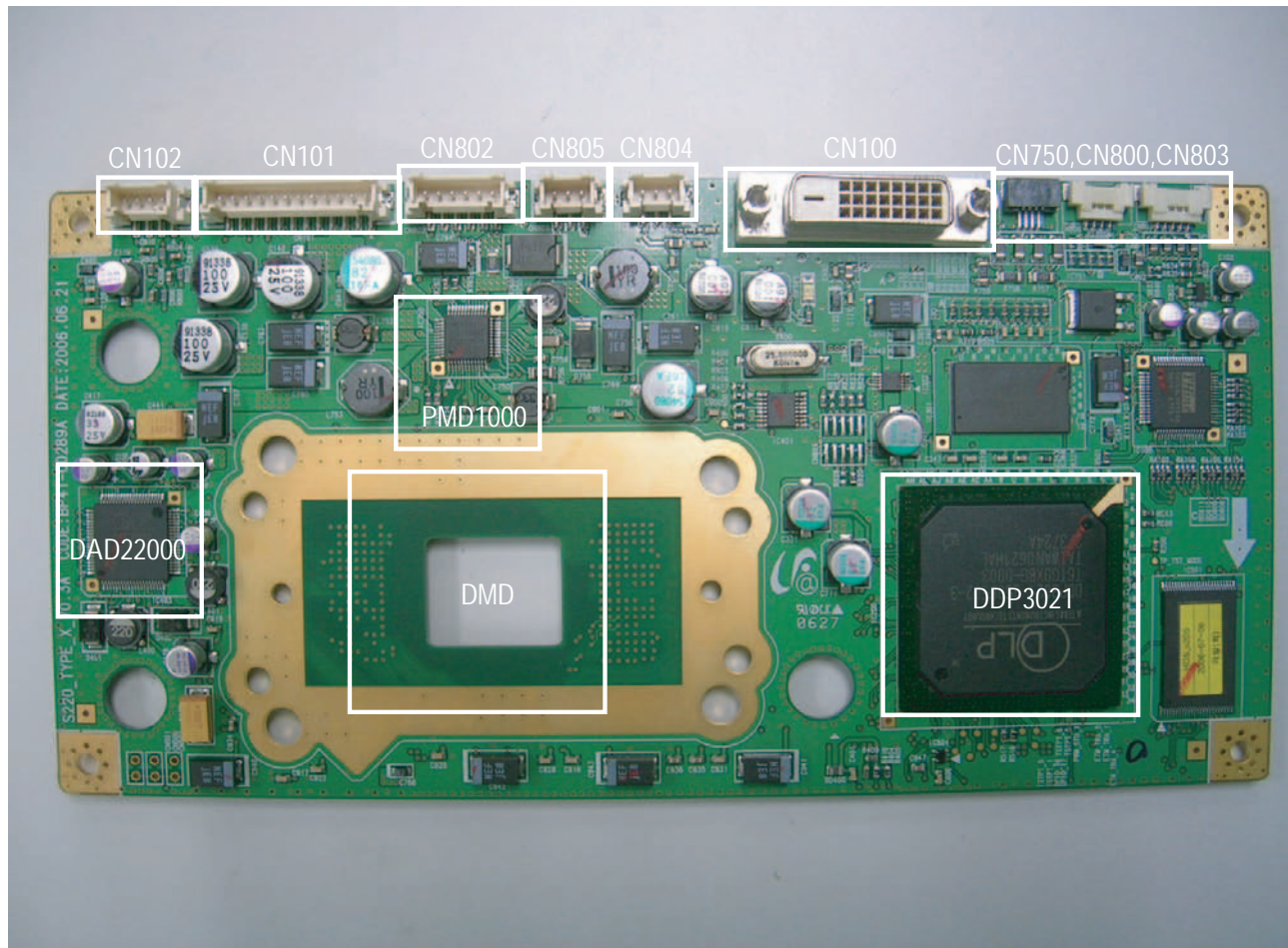

- Controls the lamp (ON/OFF)
- Drives the color wheel motor
- Drives the panel

9-3-2 Names & Roles of Key Parts

- * CN101 : This receives the power source from the Main board and communicates with the I2C.
- * CN102 : This sends a 60Hz signal to the signal to the actuator module.
- * CN750 : This supplies the power to drive the color wheel.
- * CN800 : This receives the color wheel rotating signals.
- * CN803 : This sends signals to the ballast.
- * CN802 : This receives protection signal.
- * CN804,CN805 : This supplies the power to Fan.
- * CN100 : The DVI cable terminal. This receives the image data from the digital board.
- * DMD PANEL : This is protected with a heat sink and fixtures.
- * DDP3021 : This processes the DMD drive and the signals.
- * PMD1000 : This supplies the DMD Board power and controls the color wheel rotating.
- * DAD2000 : This supplies DMD reset signals.

MEMO

10. Schematic Diagram

10-1 Main Board

10-1-1 Main-1

This Document can not be used without Samsung's authorization.

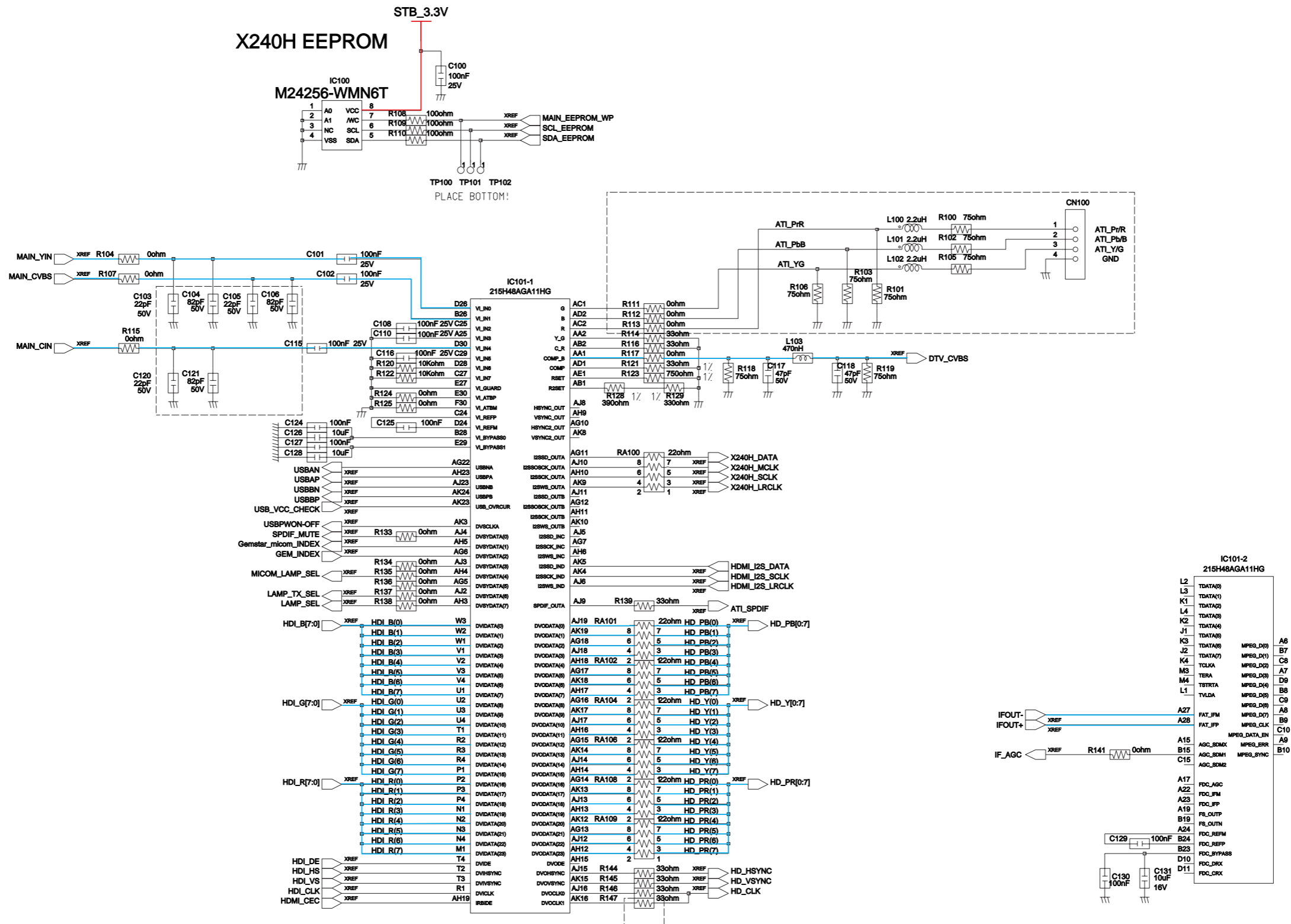
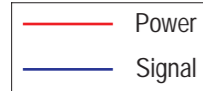

10-1-2 Main-2

This Document can not be used without Samsung's authorization.

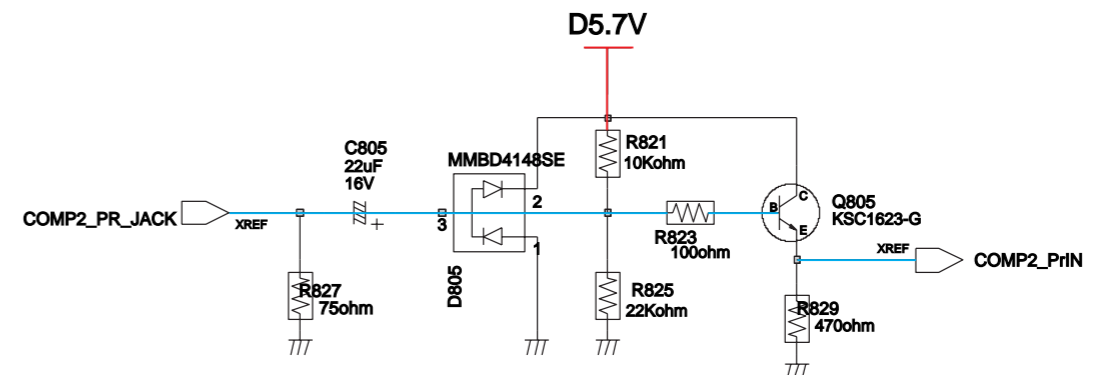
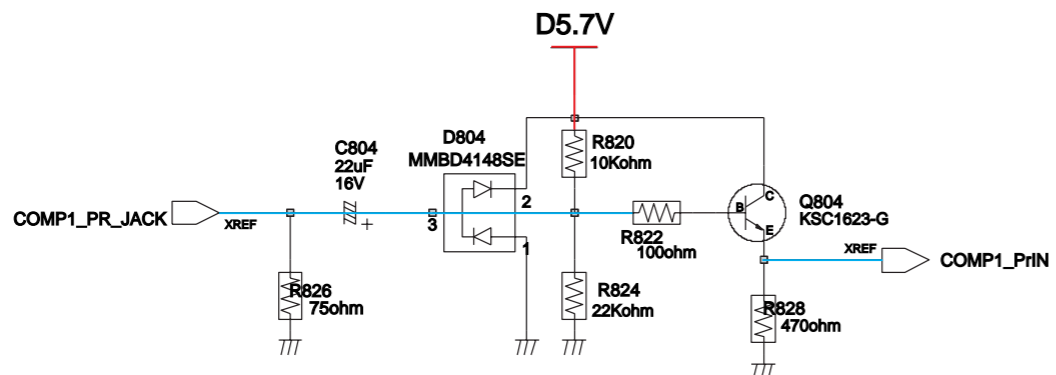
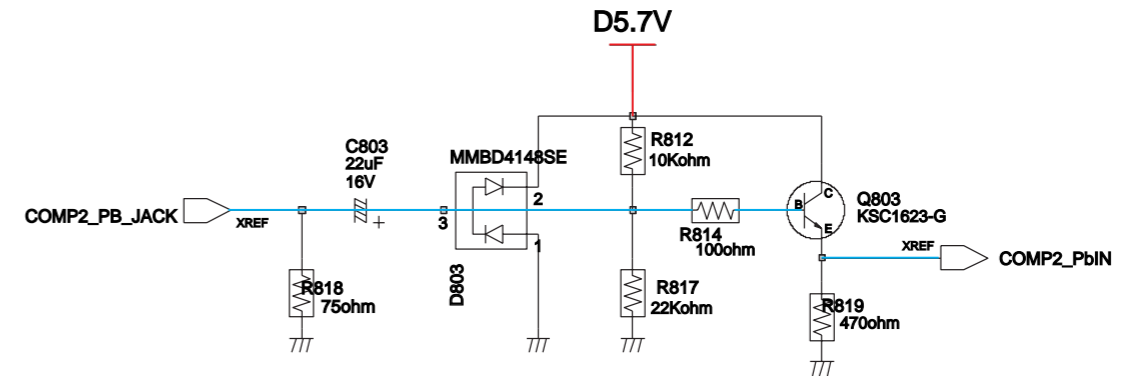
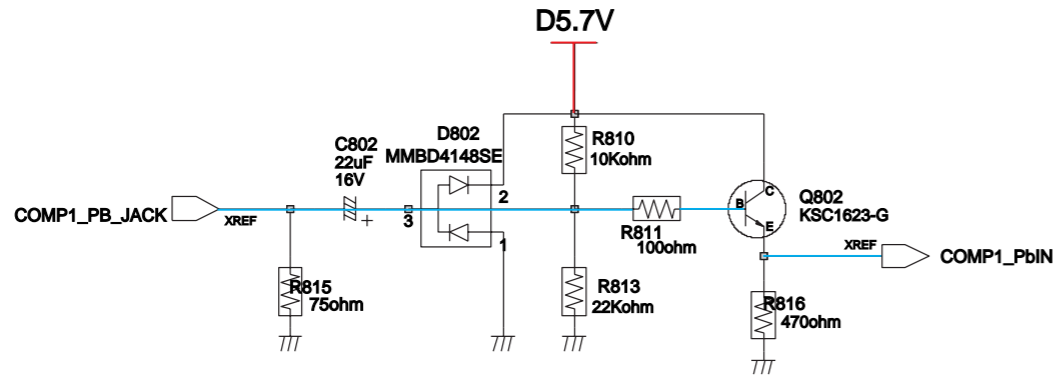
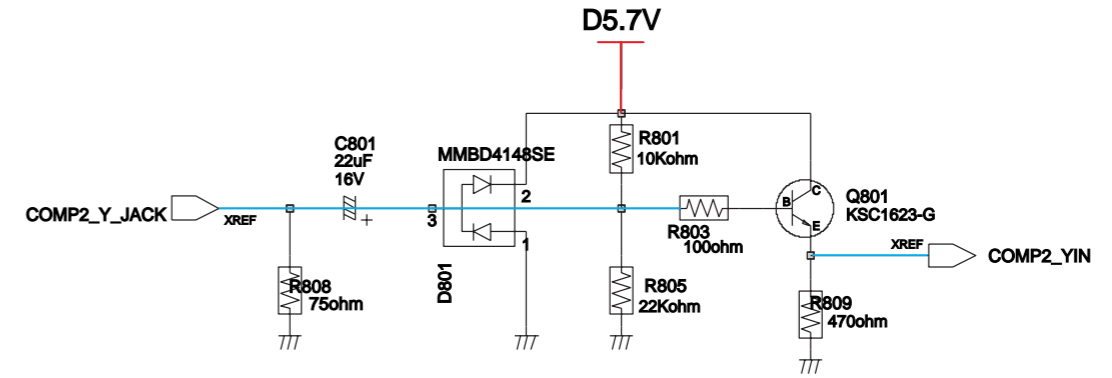
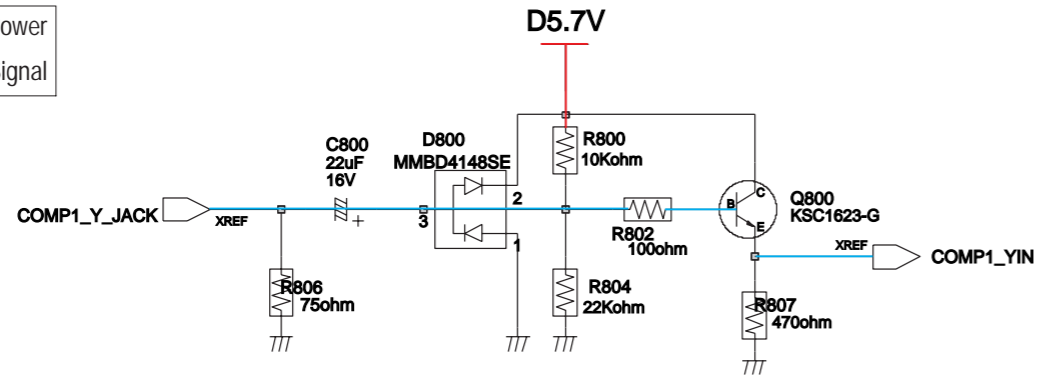

10-1-3 Main-3

This Document can not be used without Samsung's authorization.

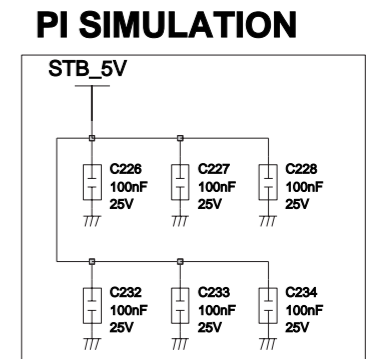
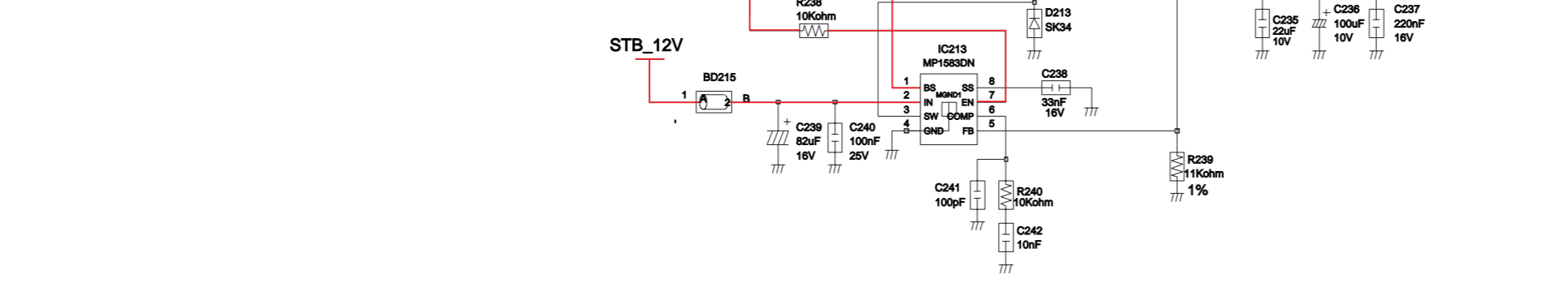
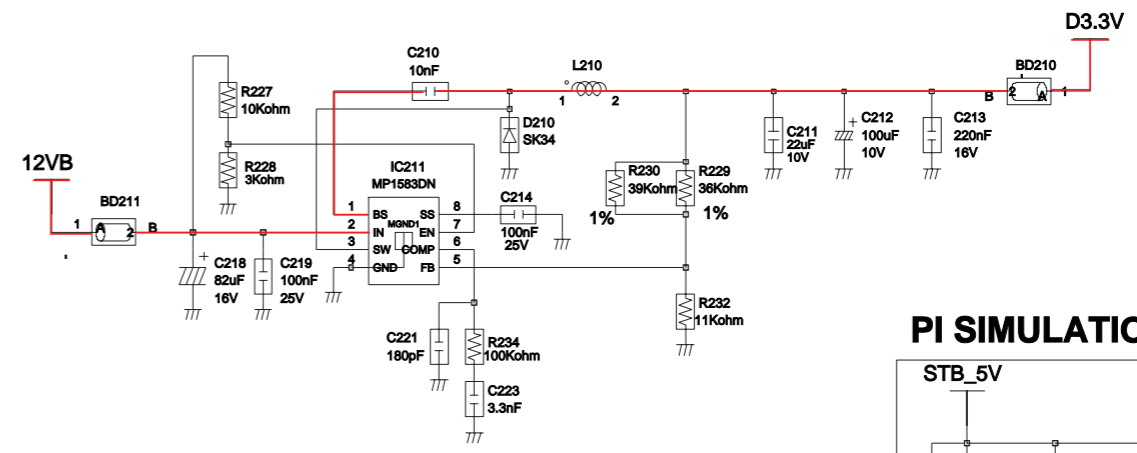
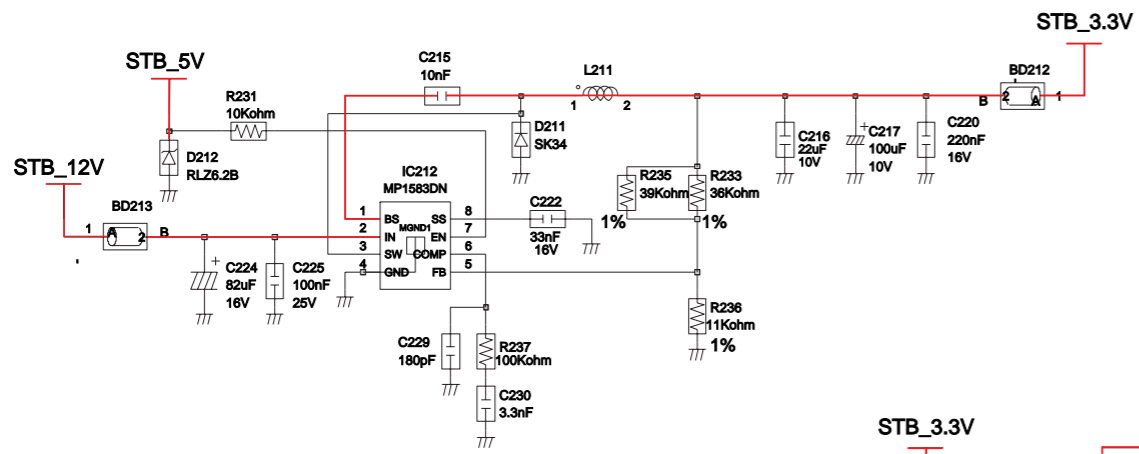
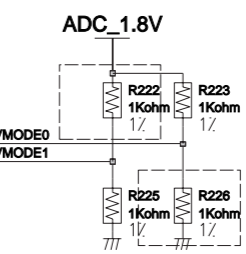
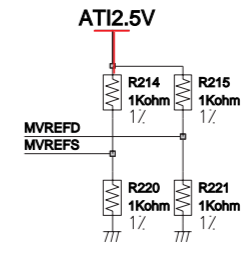
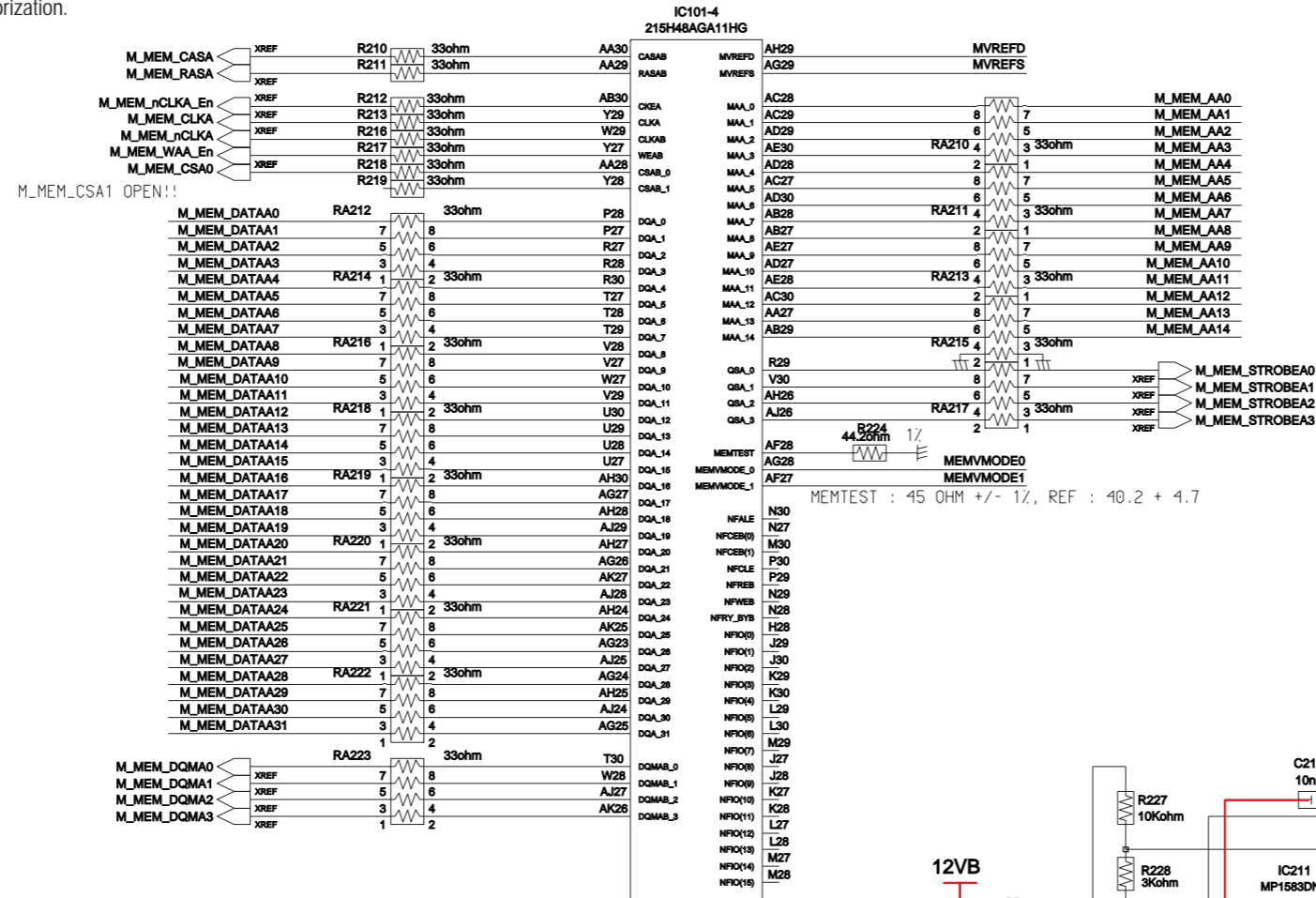
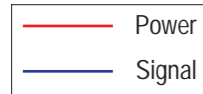

10-1-4 Main-4

This Document can not be used without Samsung's authorization.

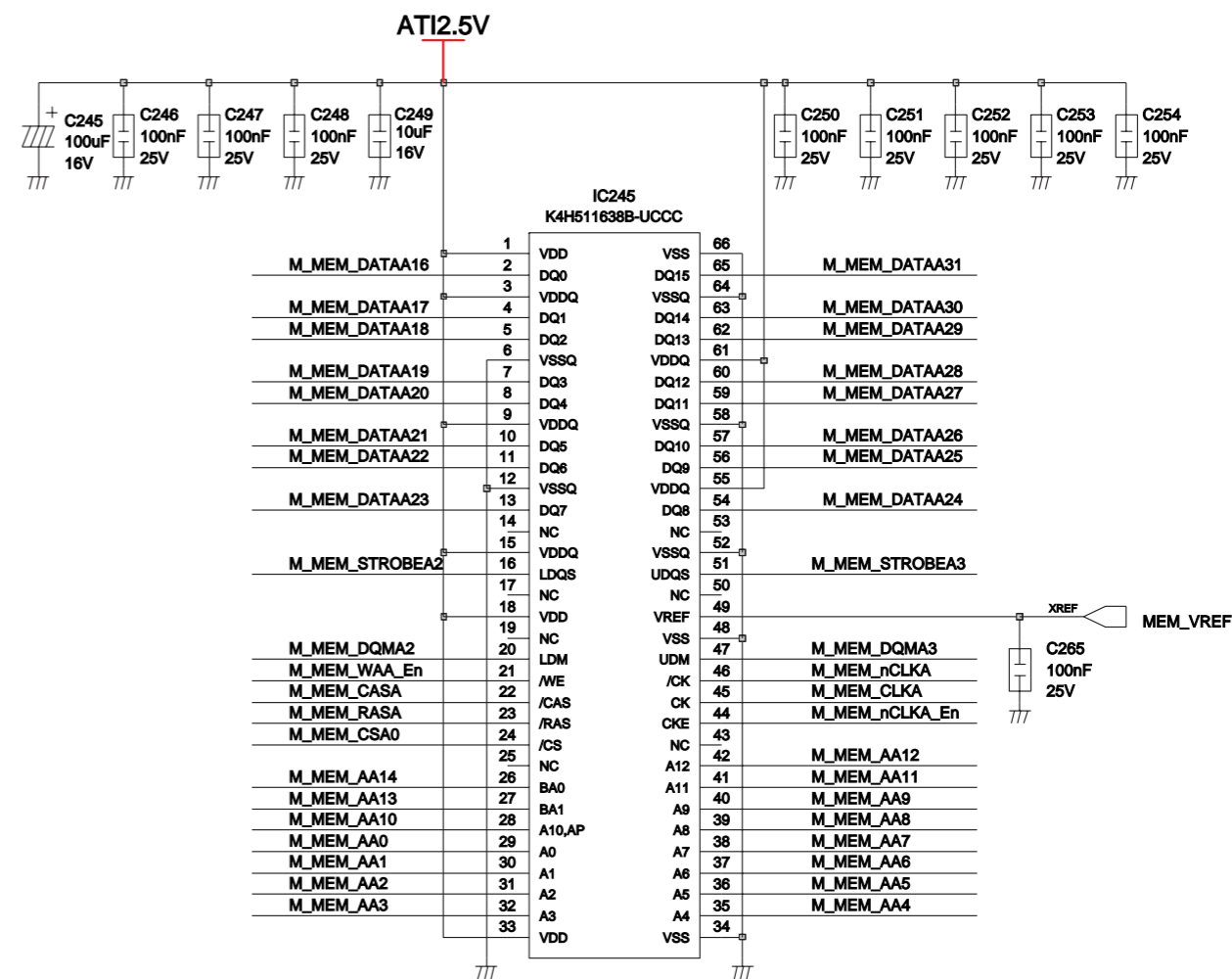
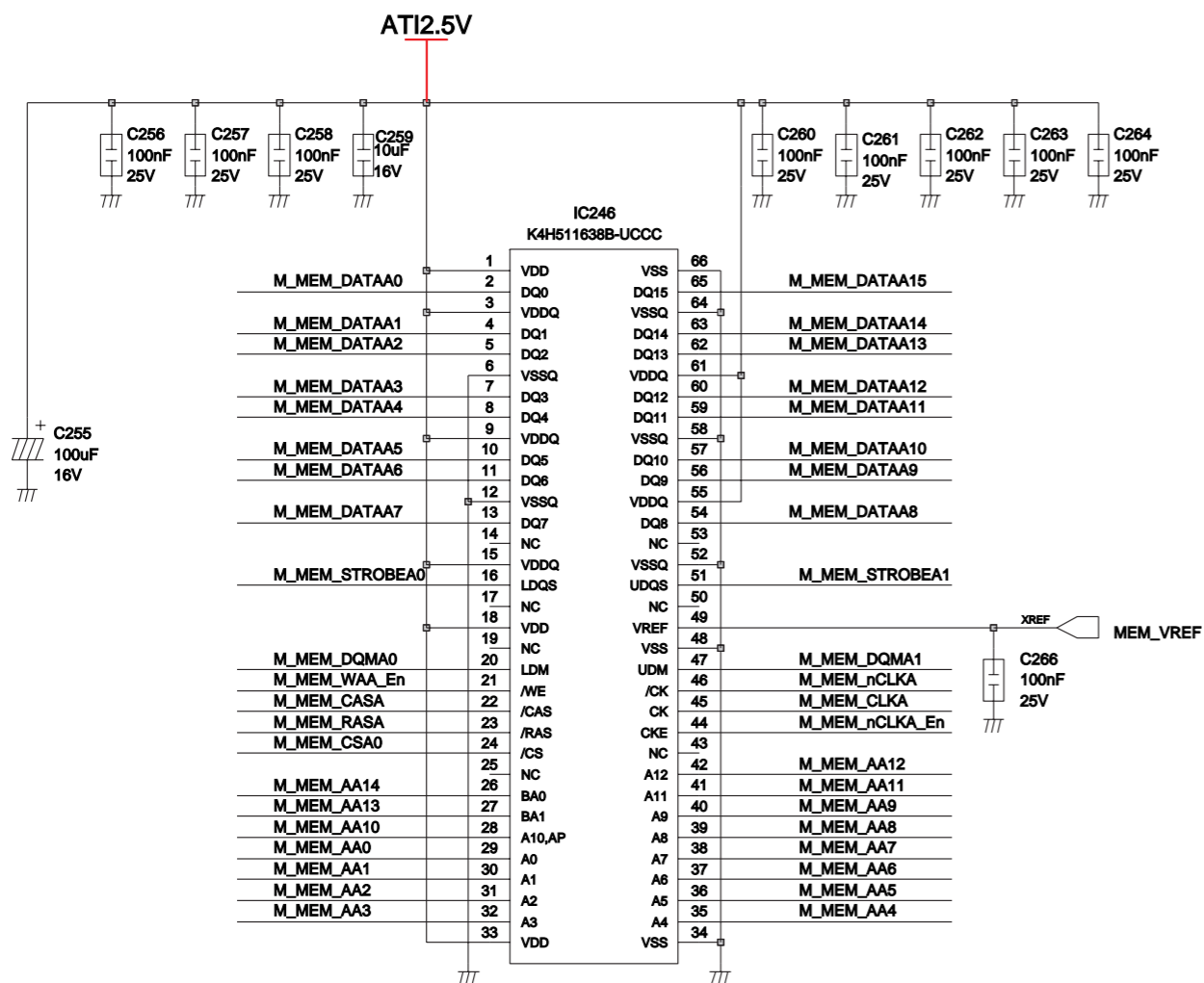
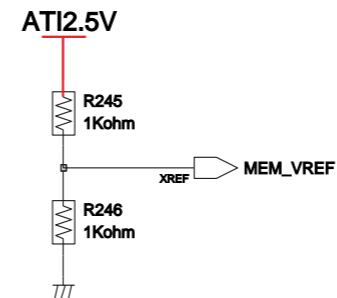
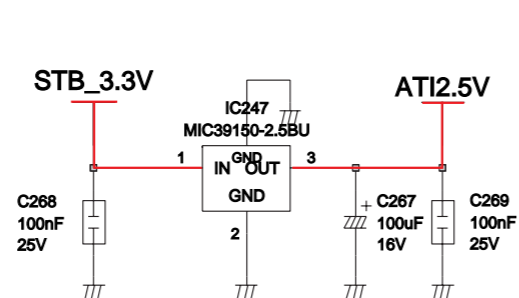
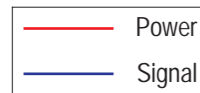

10-1-5 Main-5

This Document can not be used without Samsung's authorization.

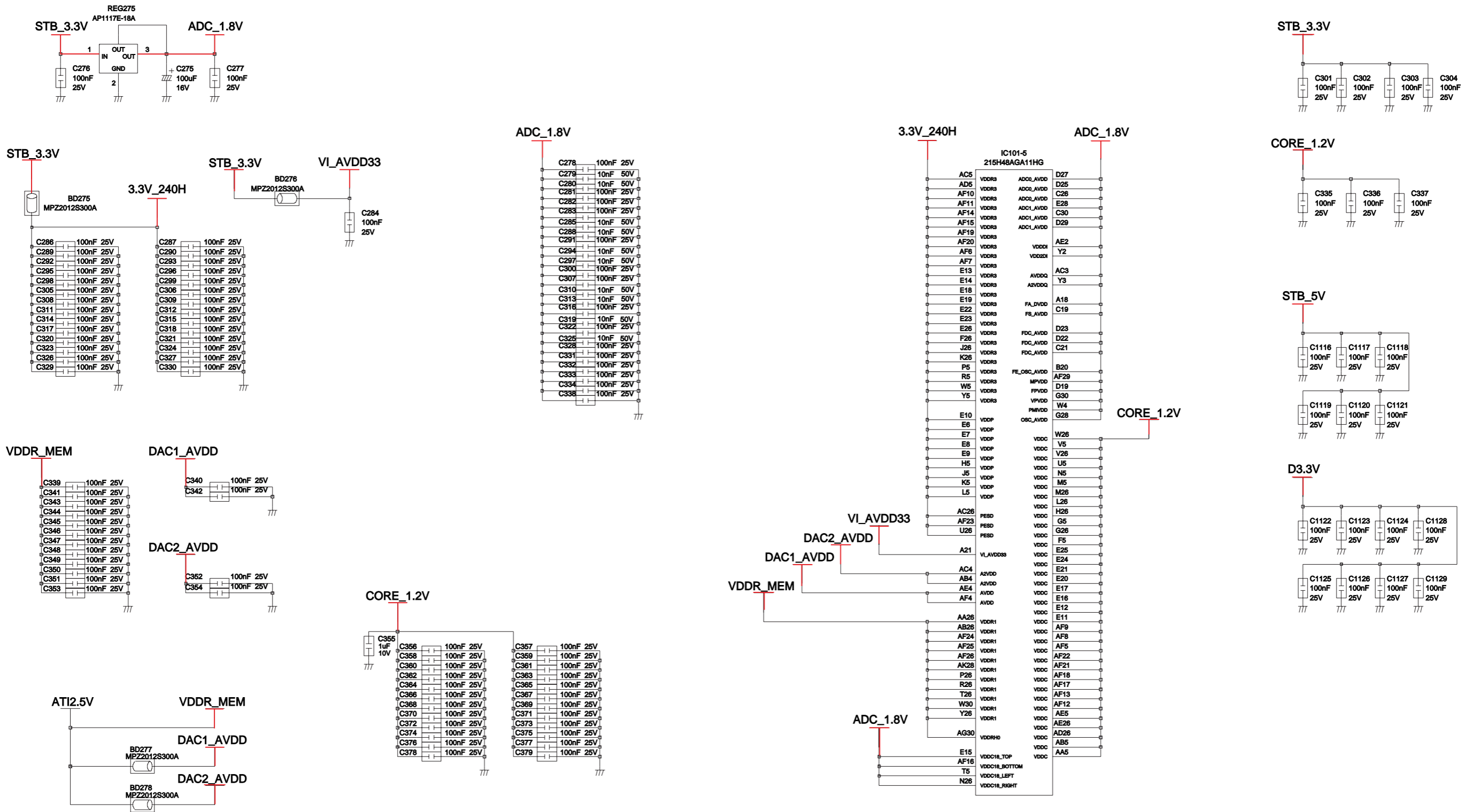
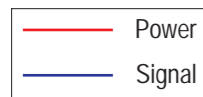

10-1-6 Main-6

This Document can not be used without Samsung's authorization.

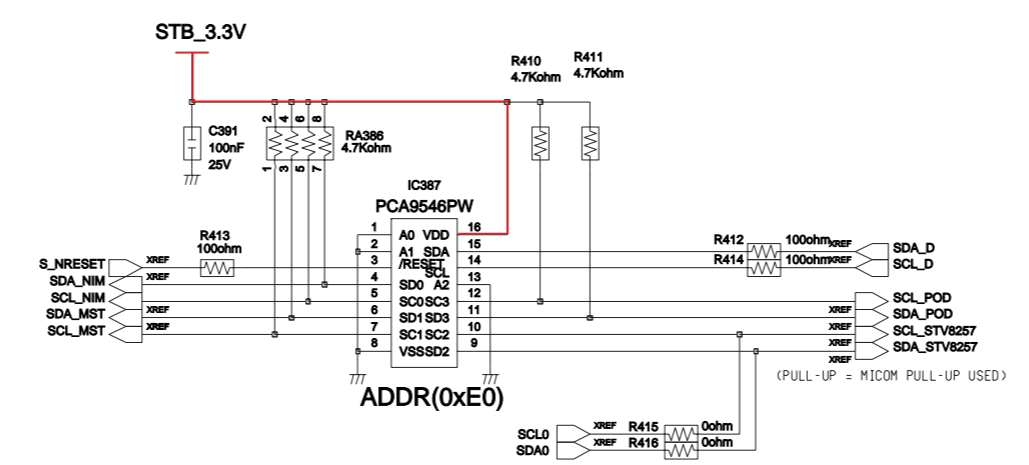
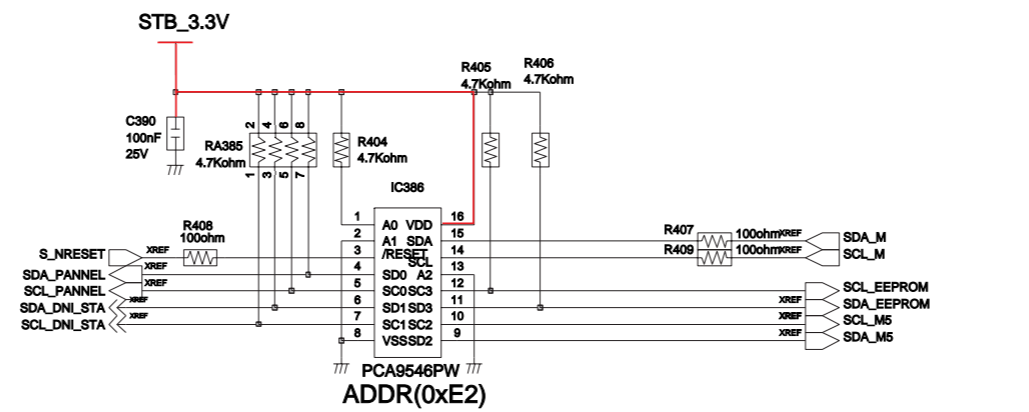
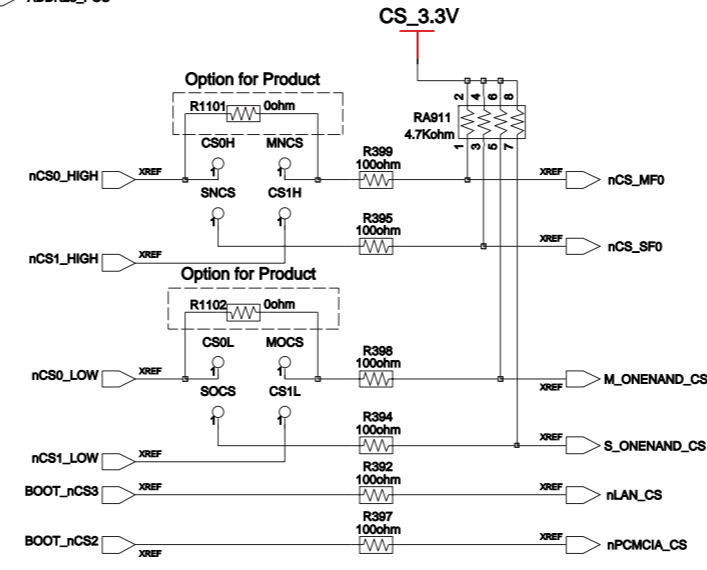
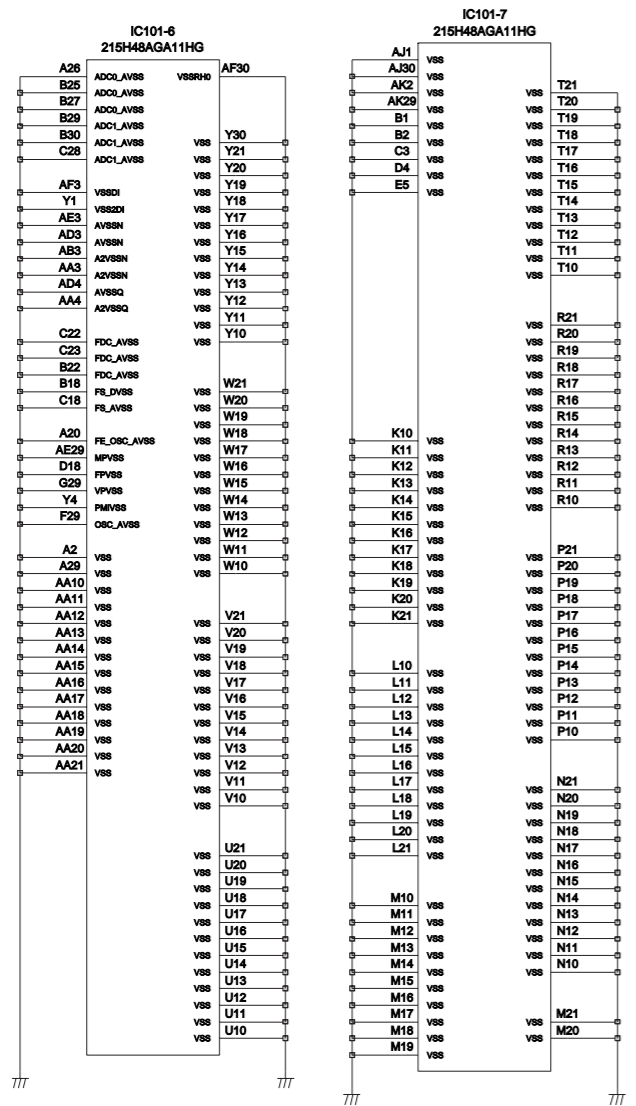
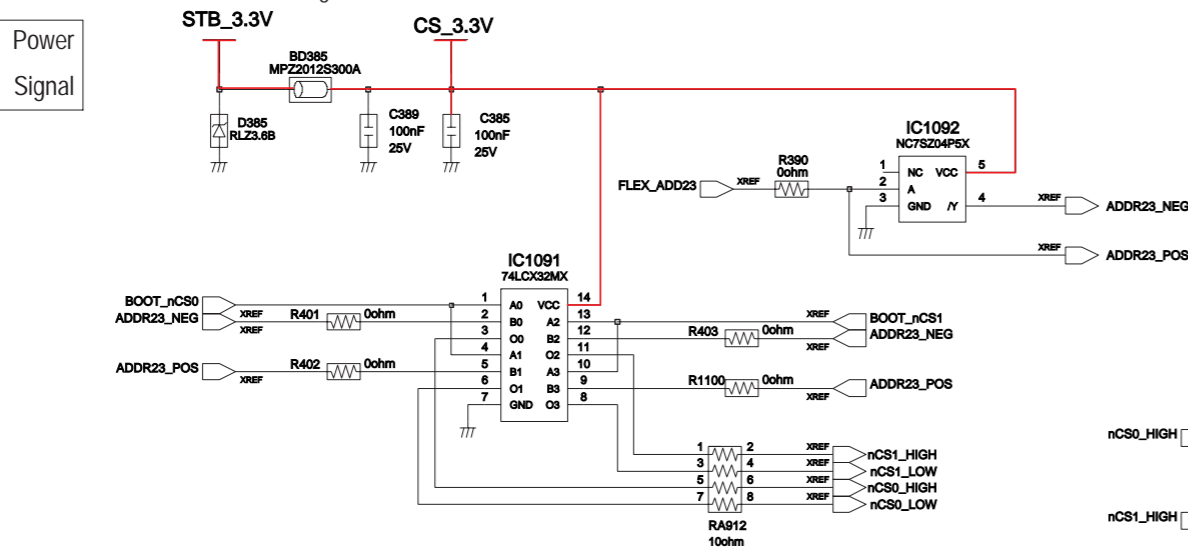

LAN CARD MODULE CONNECTOR

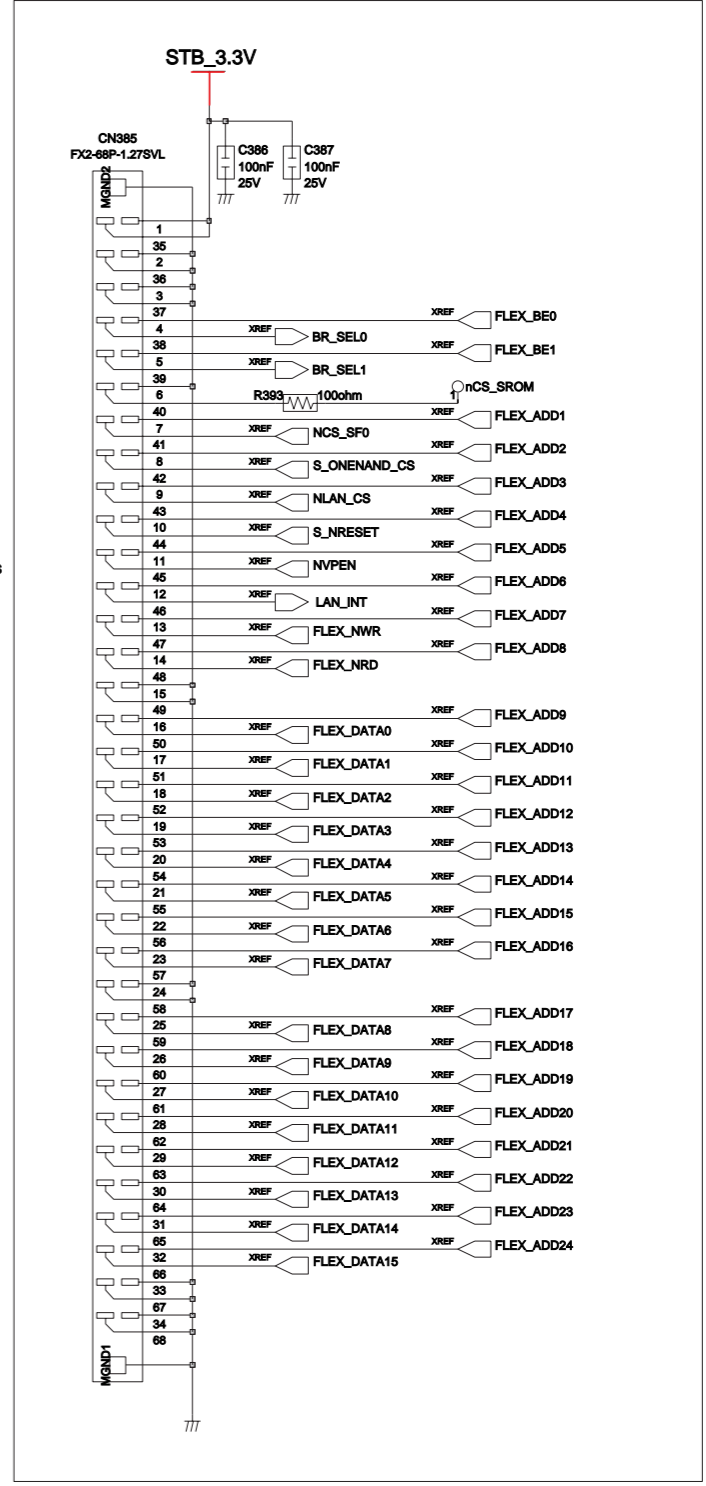

10-1-7 Main-7

This Document can not be used without Samsung's authorization.

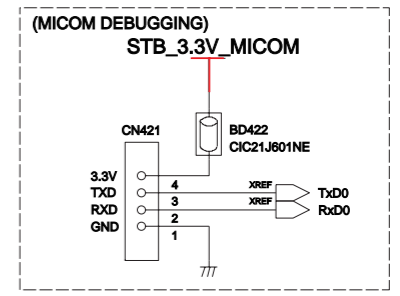
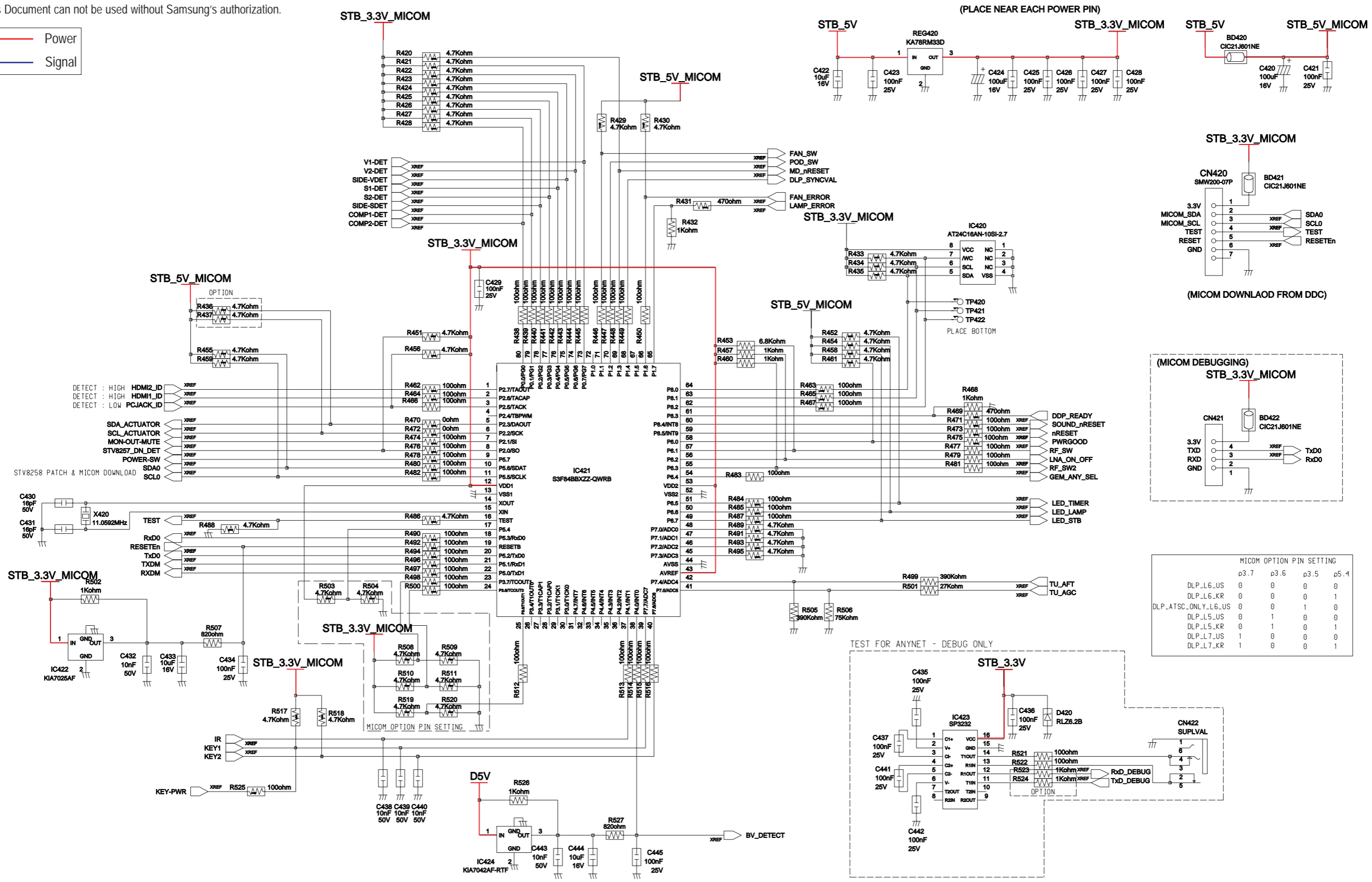

MICOM OPTION PIN SETTING

	p3.7	p3.6	p3.5	p5.4
DLP_L6_US	0	0	0	0
DLP_L6_KR	0	0	0	1
DLP_ATSC_ONLY_L6_US	0	0	1	0
DLP_L5_US	0	1	0	0
DLP_L5_KR	0	1	0	1
DLP_L7_US	1	0	0	0
DLP_L7_KR	1	0	0	1

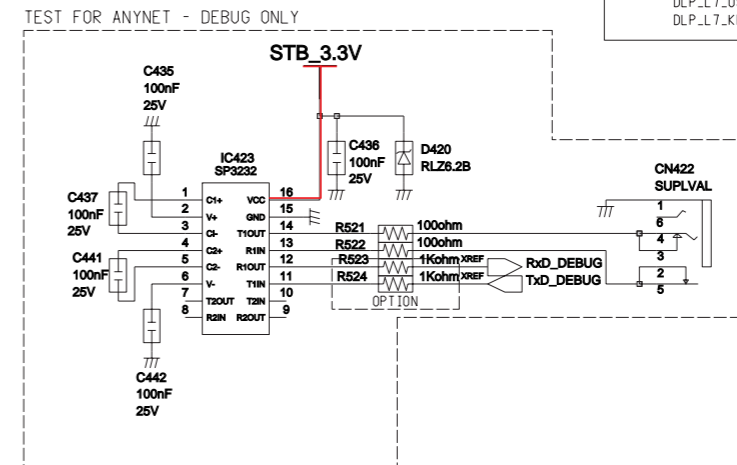

10-1-8 Main-8

This Document can not be used without Samsung's authorization.

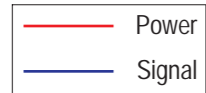

FOR GEMSTAR APPLCIATOIN

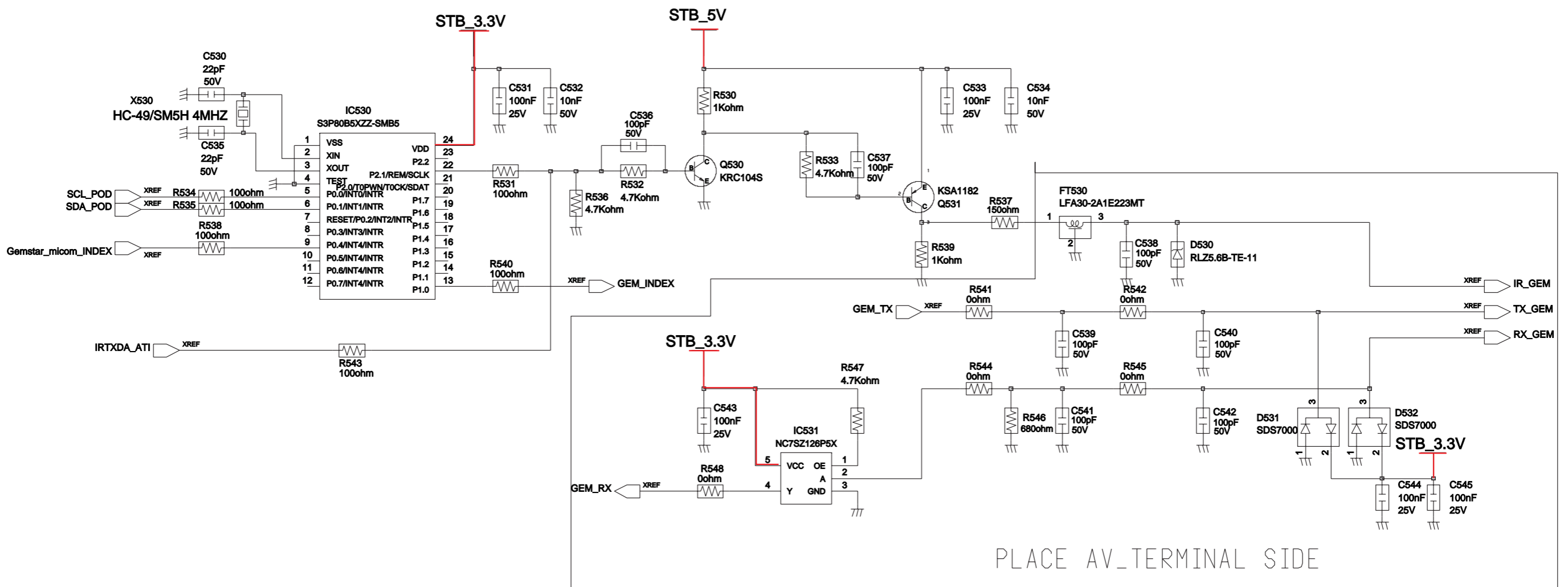

10-1-9 Main-9

This Document can not be used without Samsung's authorization.

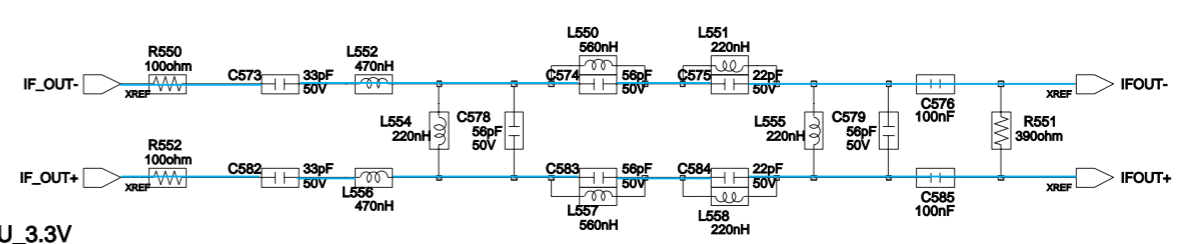
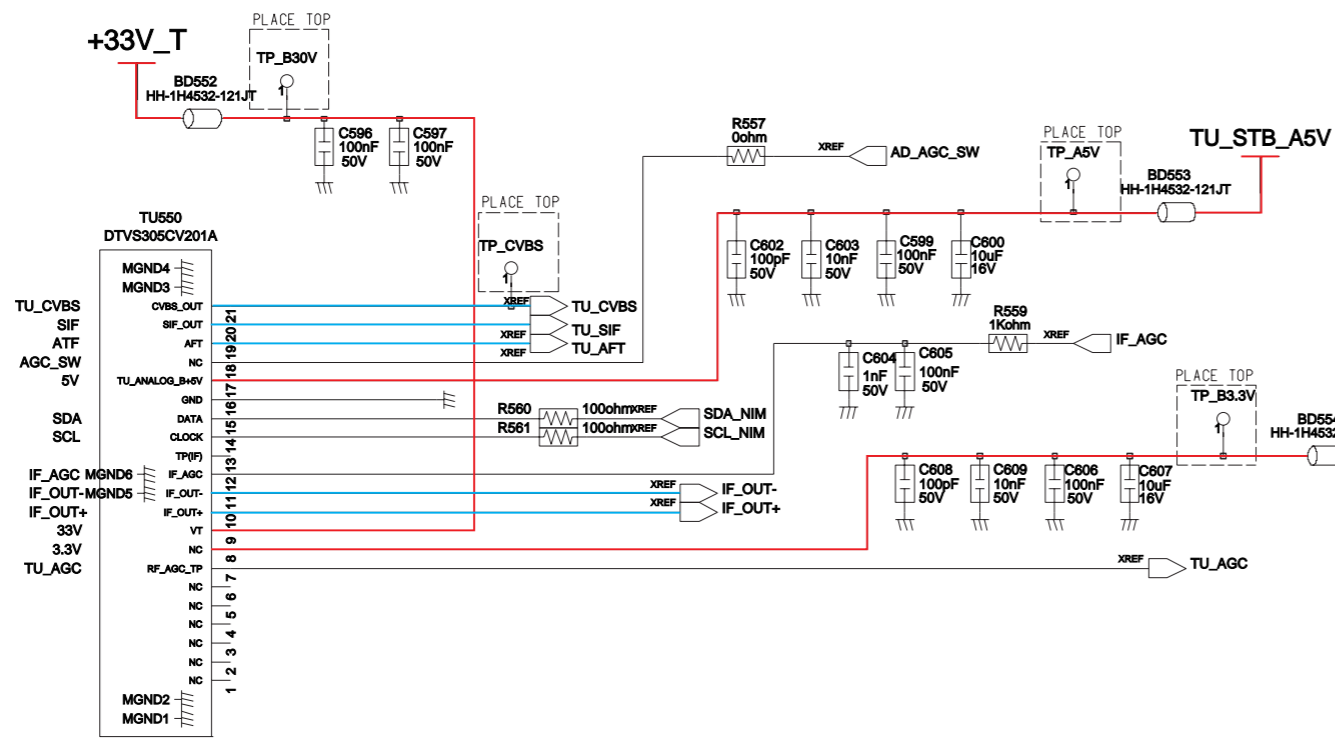
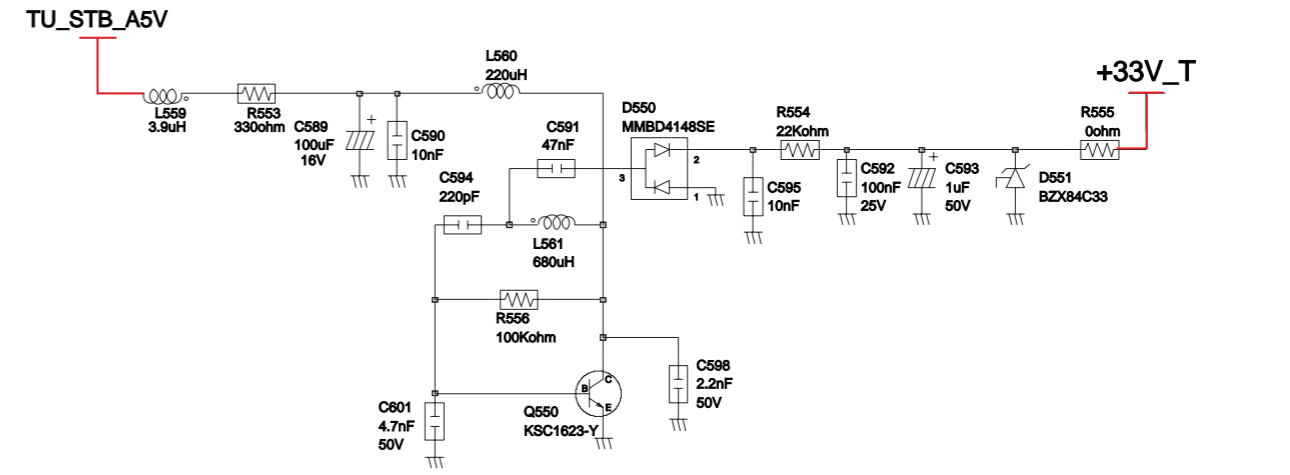
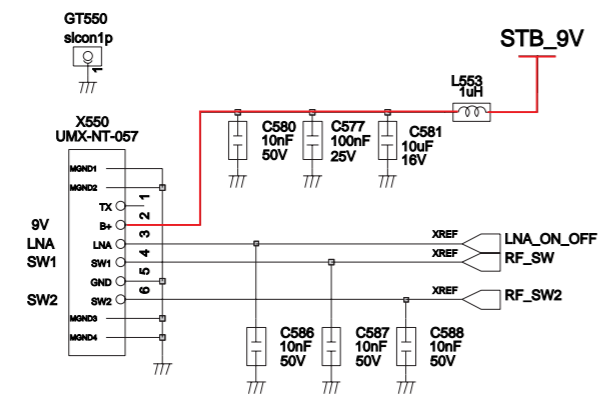
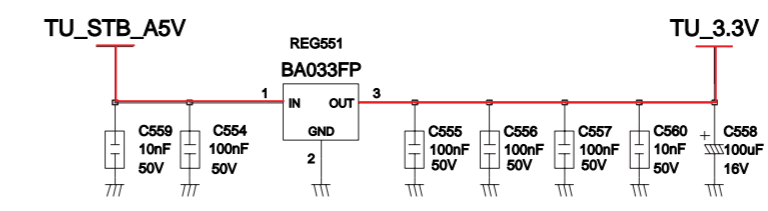
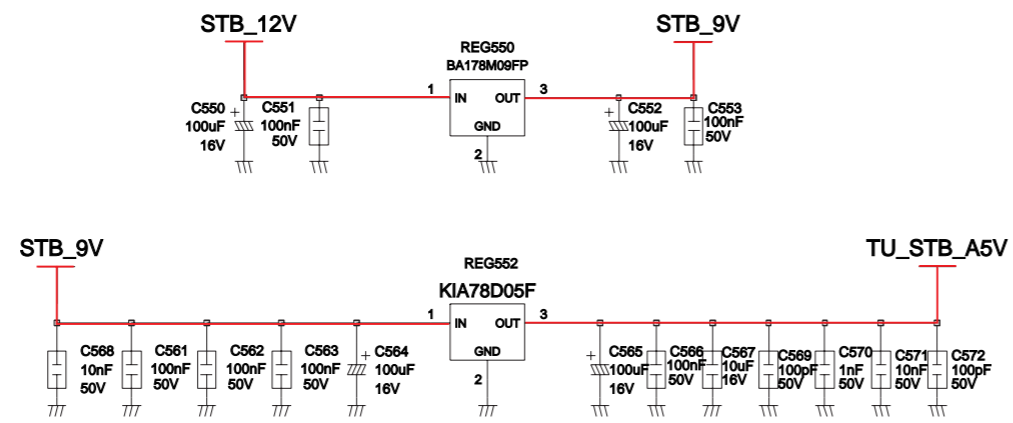
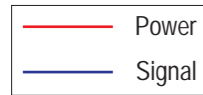

10-1-10 Main-10

This Document can not be used without Samsung's authorization.

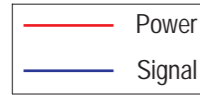

From Side AV Board Assy

JACK_BLOCK

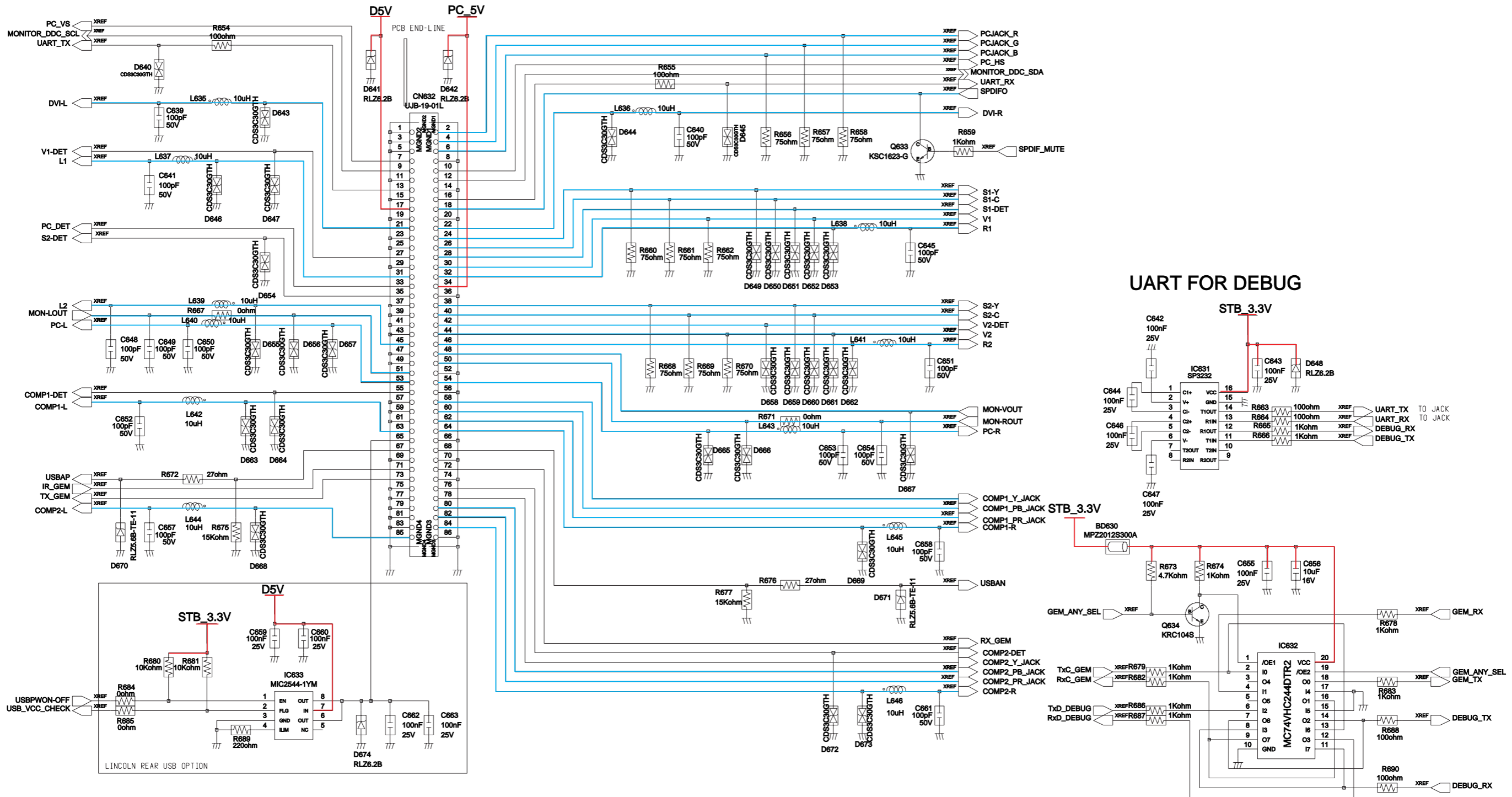

10-1-11 Main-11

This Document can not be used without Samsung's authorization.

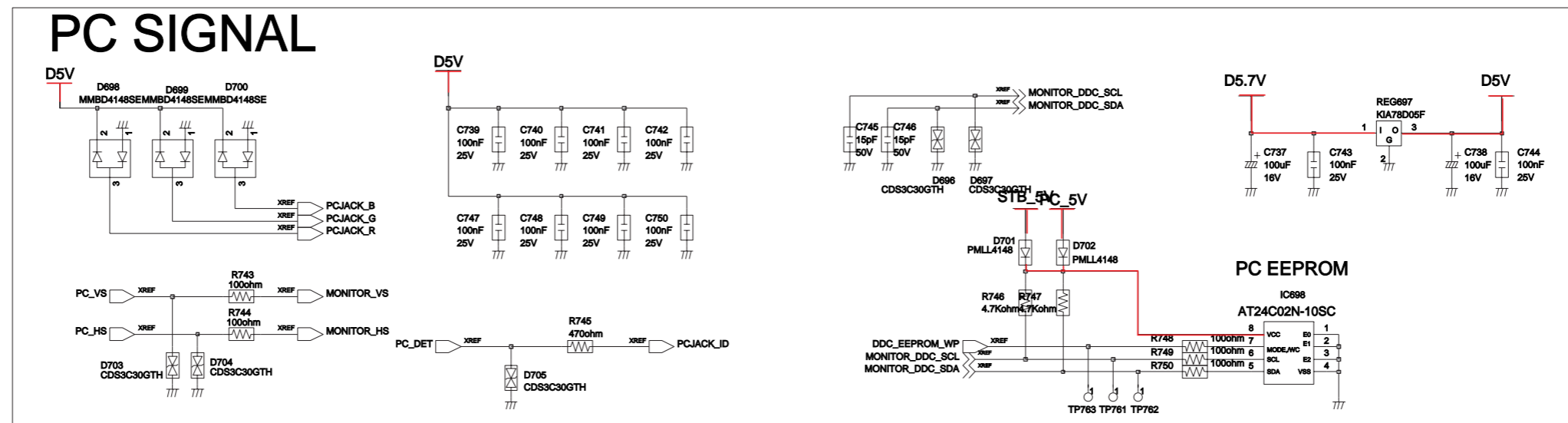
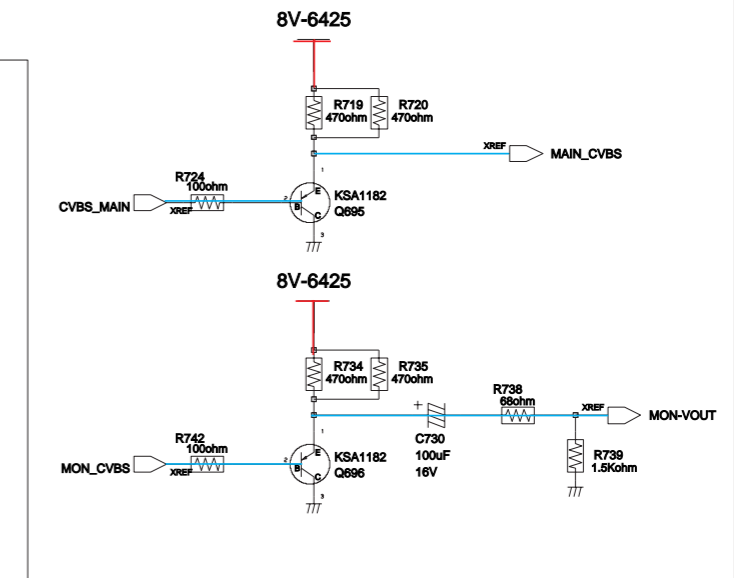
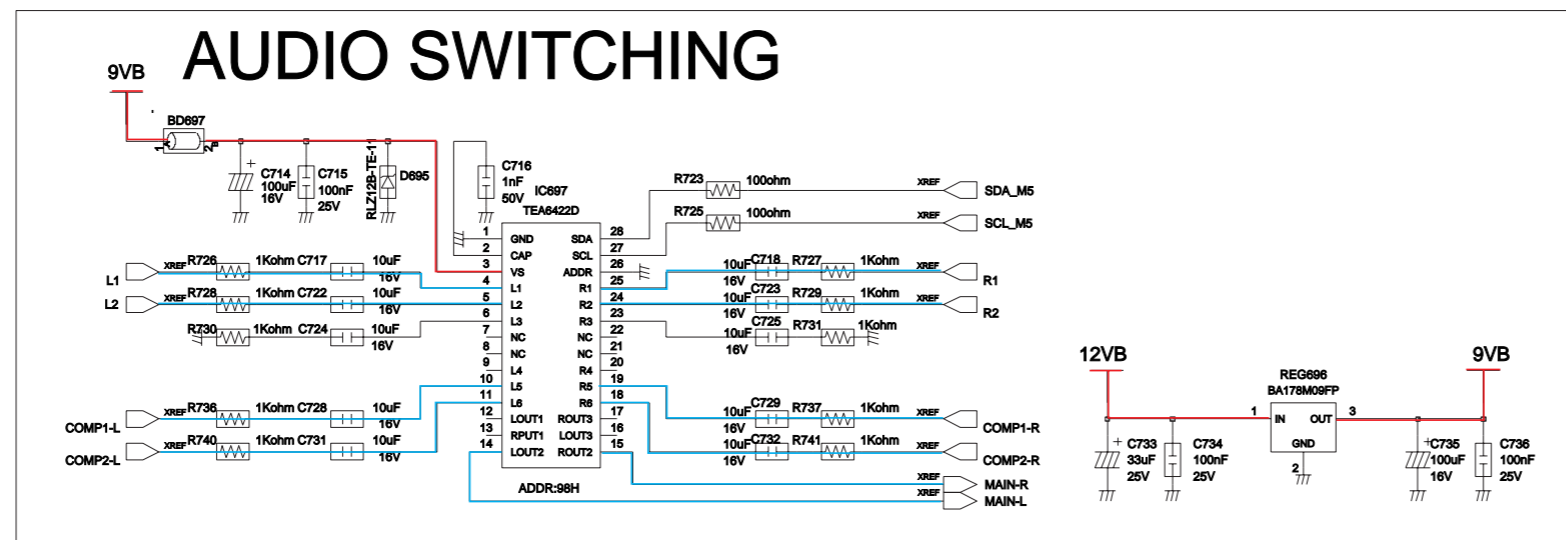
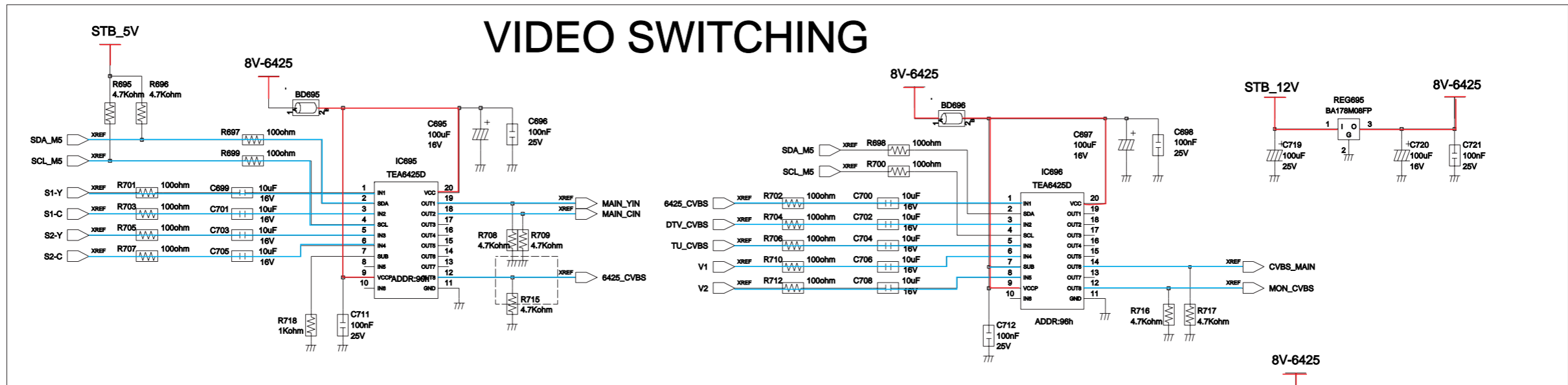
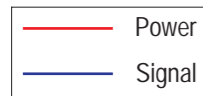

10-1-12 Main-12

This Document can not be used without Samsung's authorization.

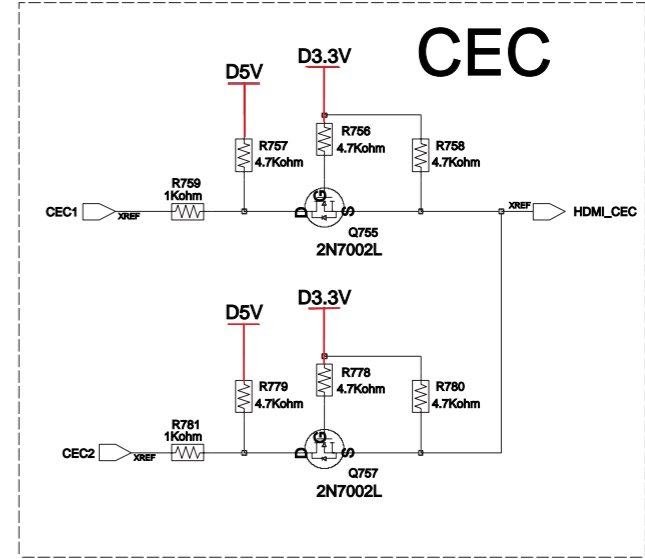
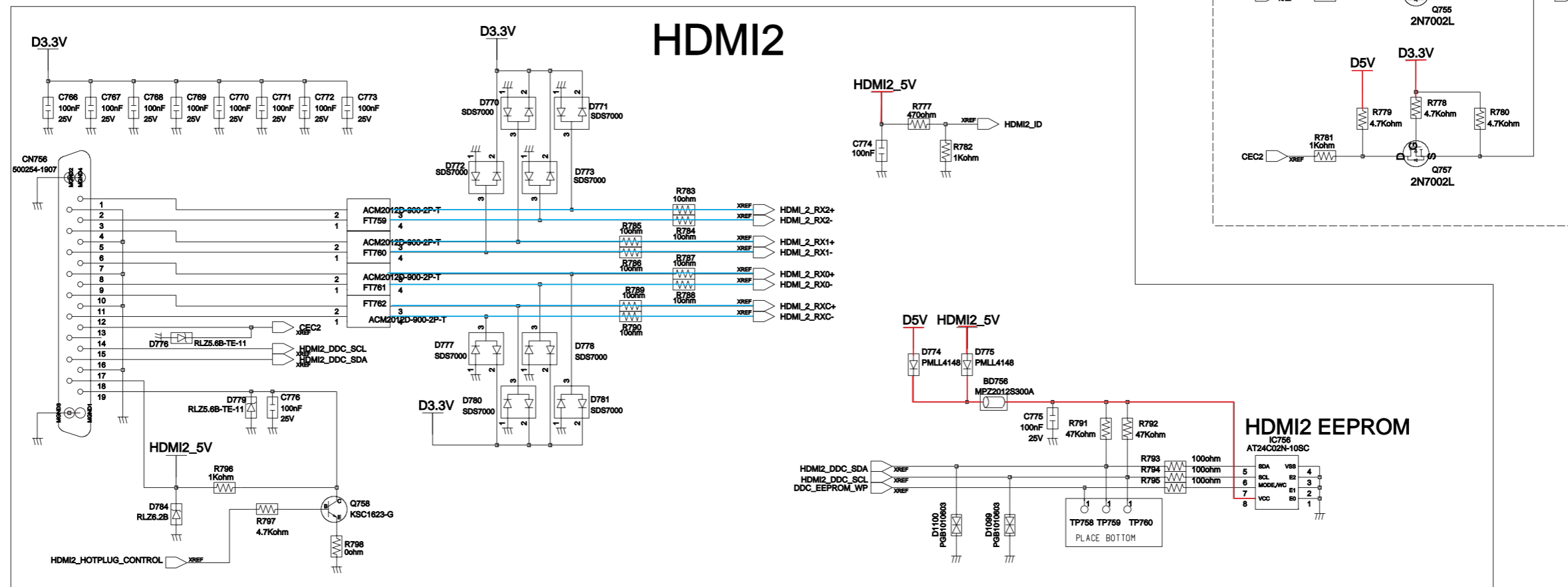
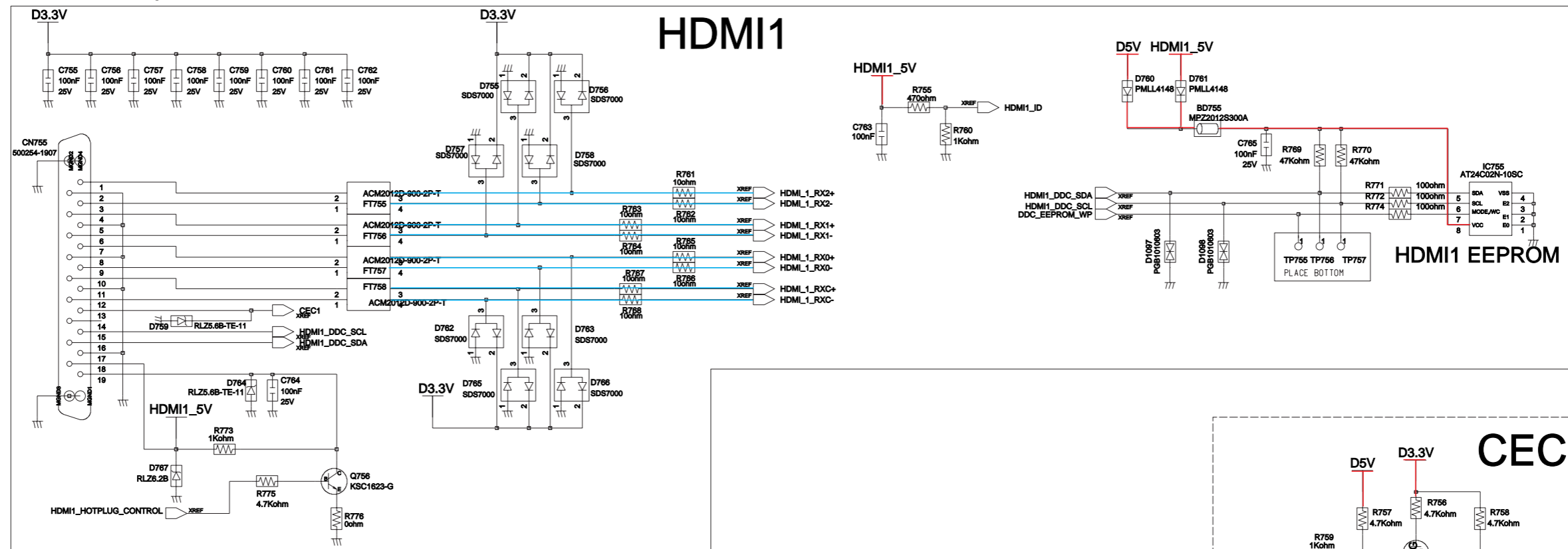
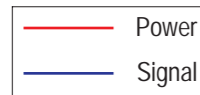

10-1-13 Main-13

This Document can not be used without Samsung's authorization.

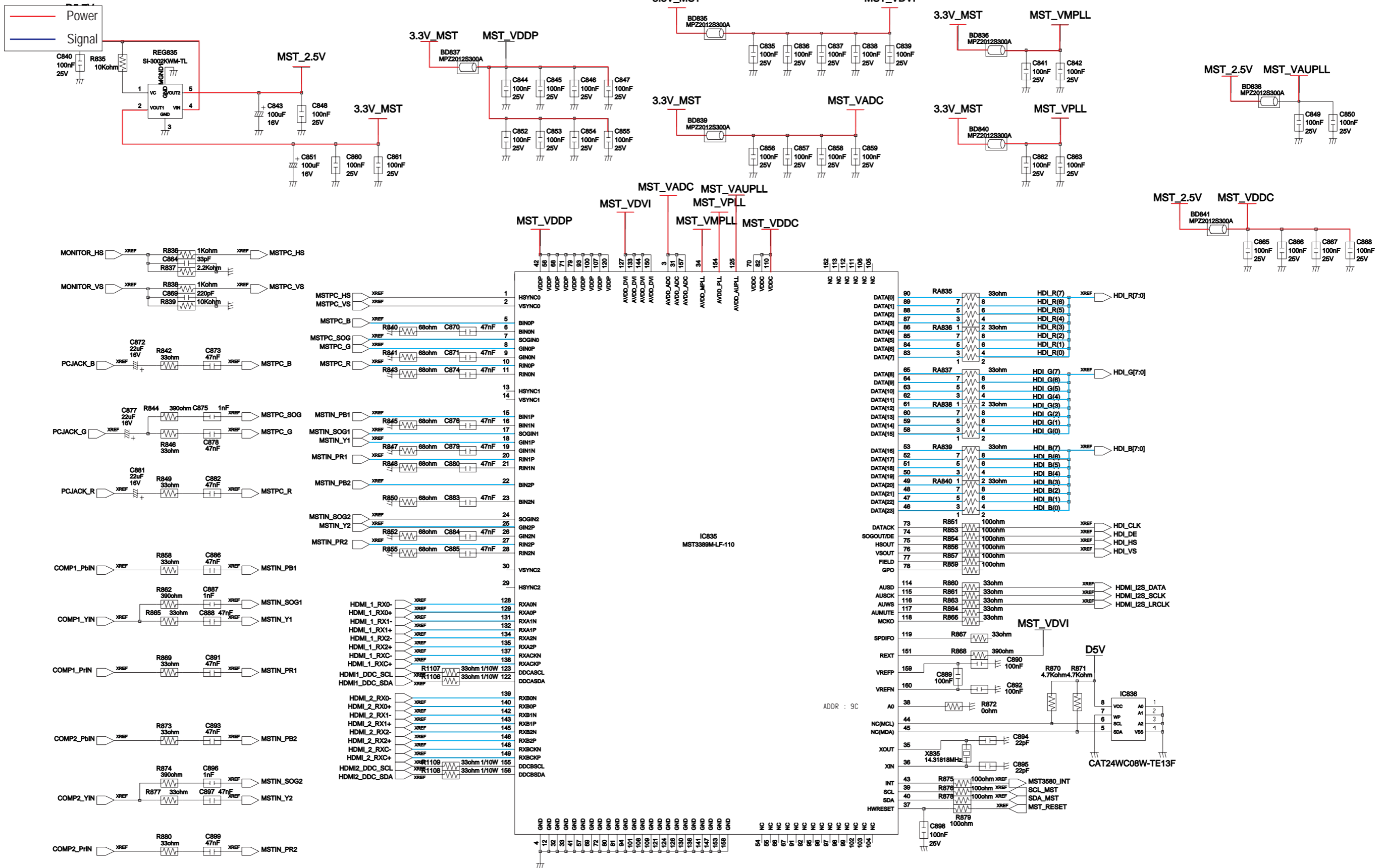

10-1-14 Main-14

This Document can not be used without Samsung's authorization.

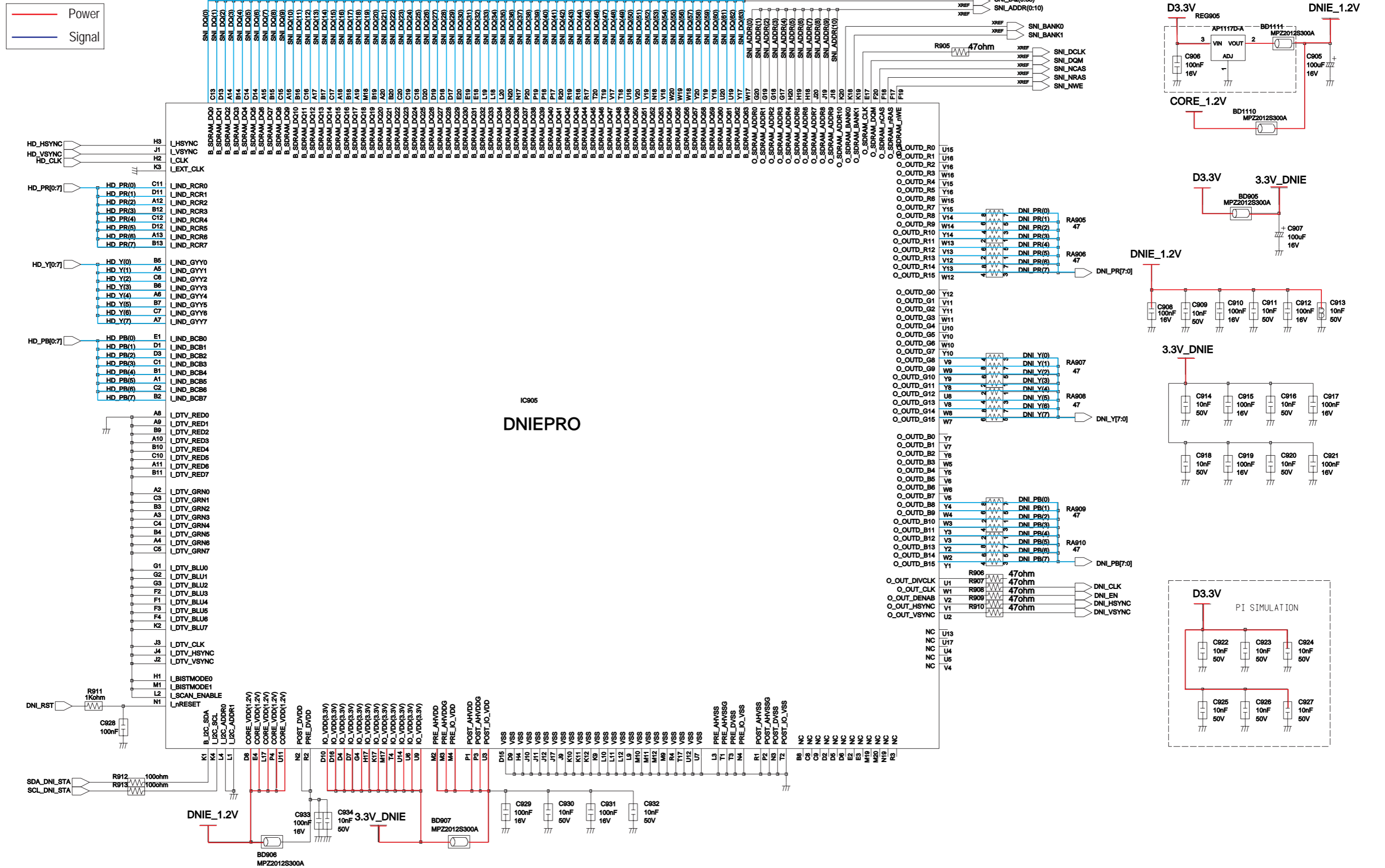

10-1-15 Main-15

This Document can not be used without Samsung's authorization.

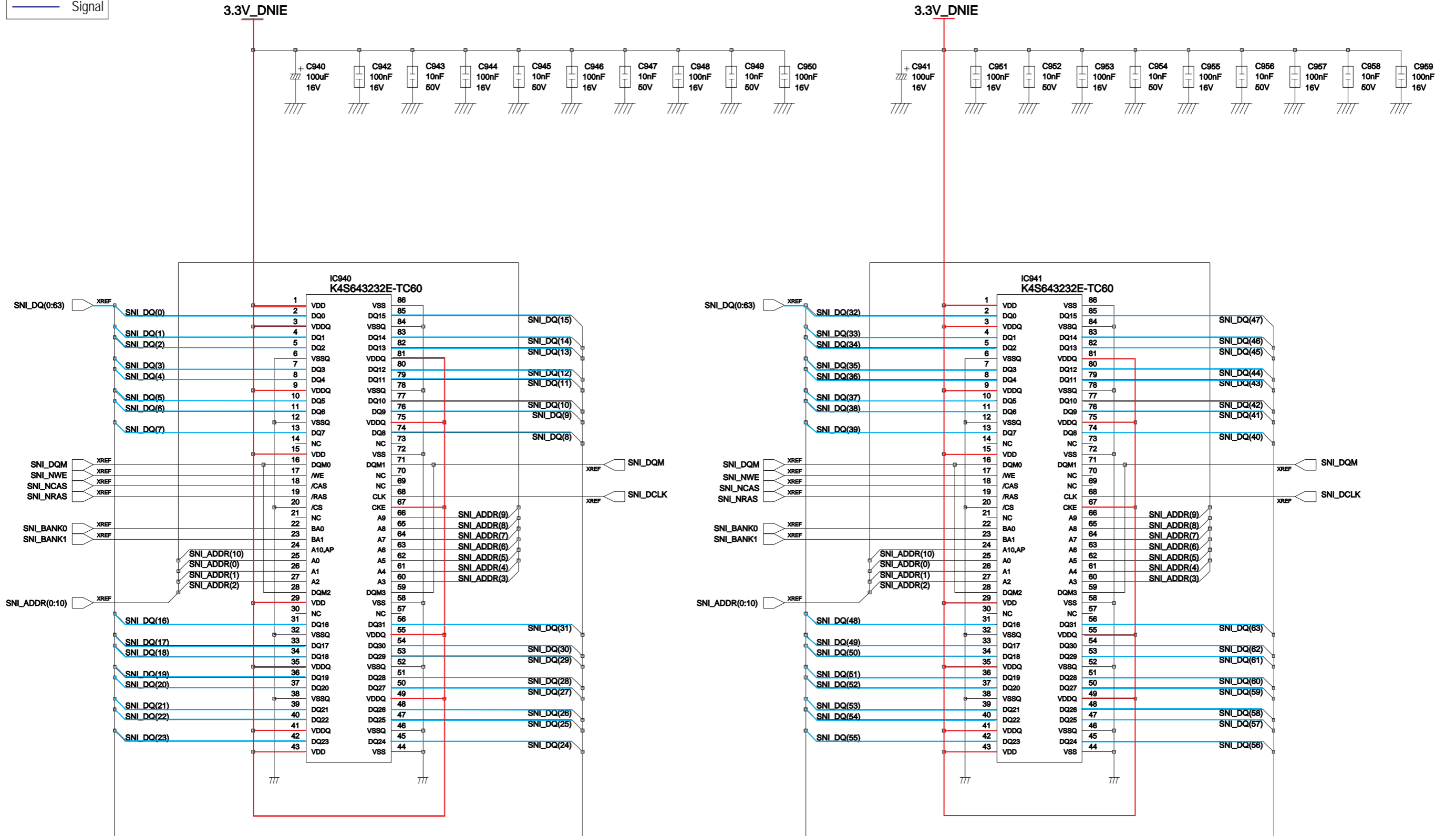

10-1-16 Main-16

This Document can not be used without Samsung's authorization.

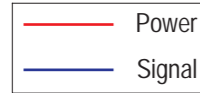

R1054/R1053 Option
 H : Rising Edge Strobe
 L : Falling Edge Strobe

R64/R99 Option
 H : Normal Swing(350mV)
 L : Small Swing(200mV)

LVDS OUTPUT

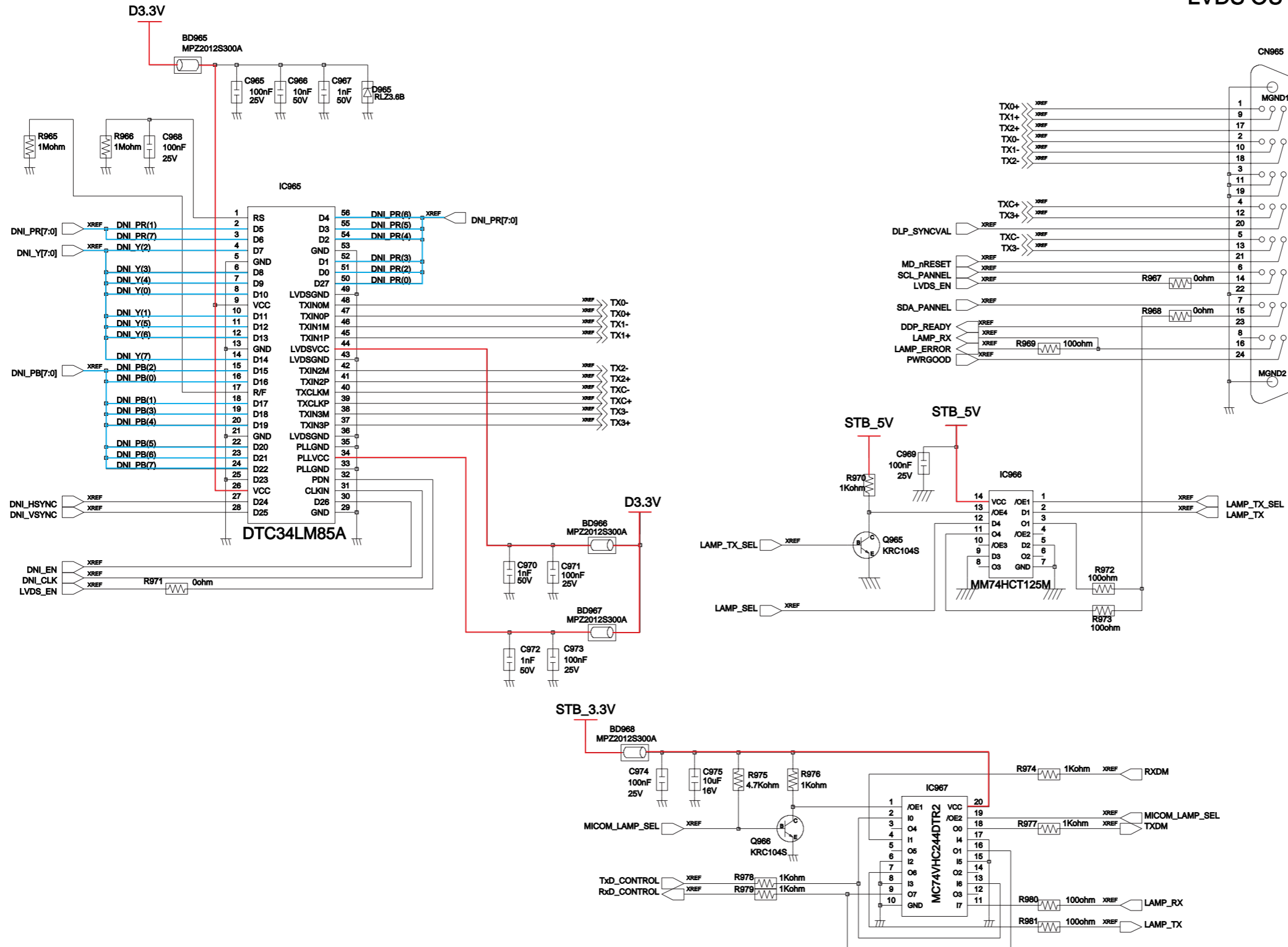

10-1-17 Main-17

This Document can not be used without Samsung's authorization.

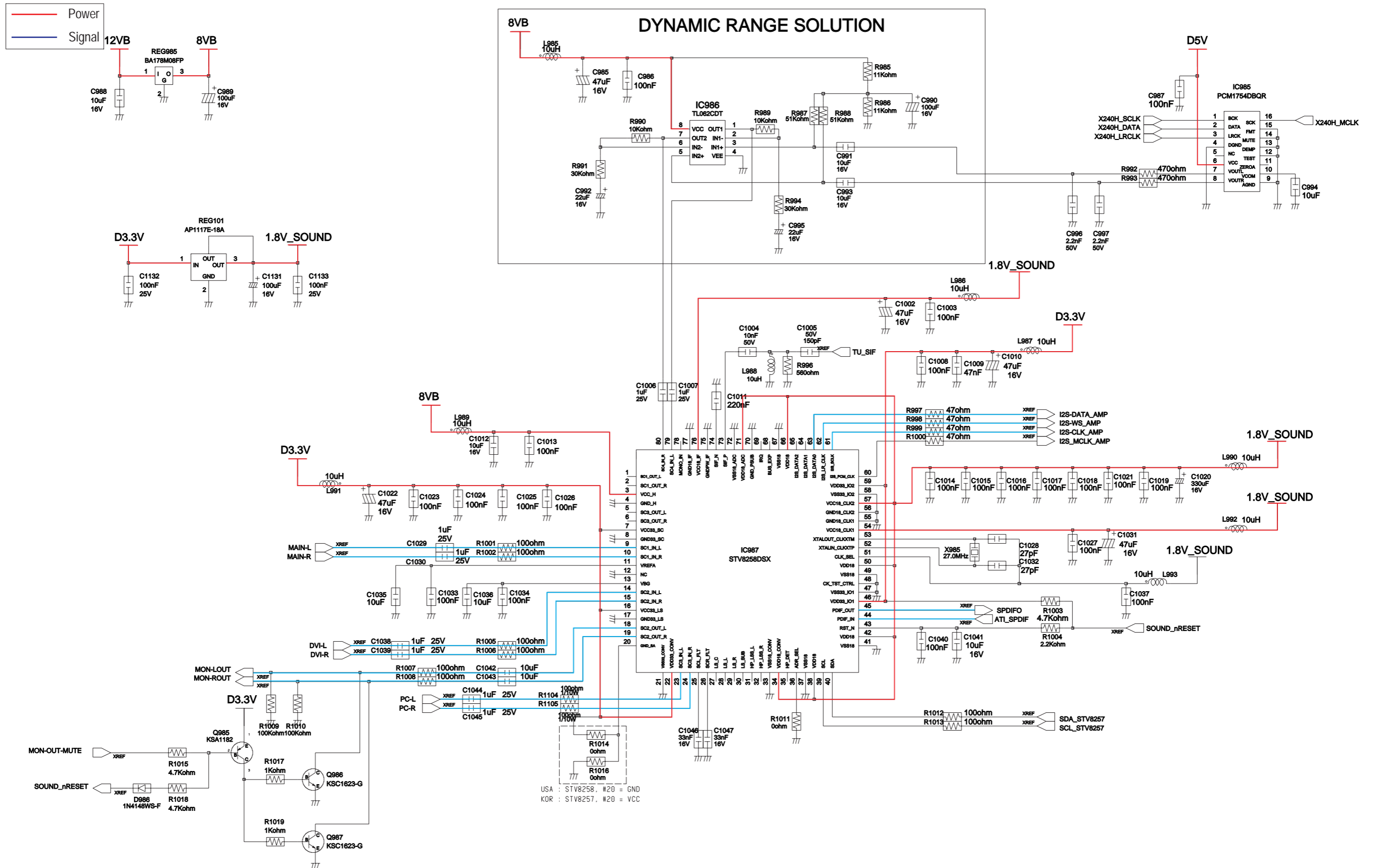

10-1-18 Main-18

This Document can not be used without Samsung's authorization.

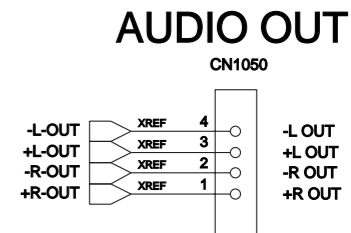
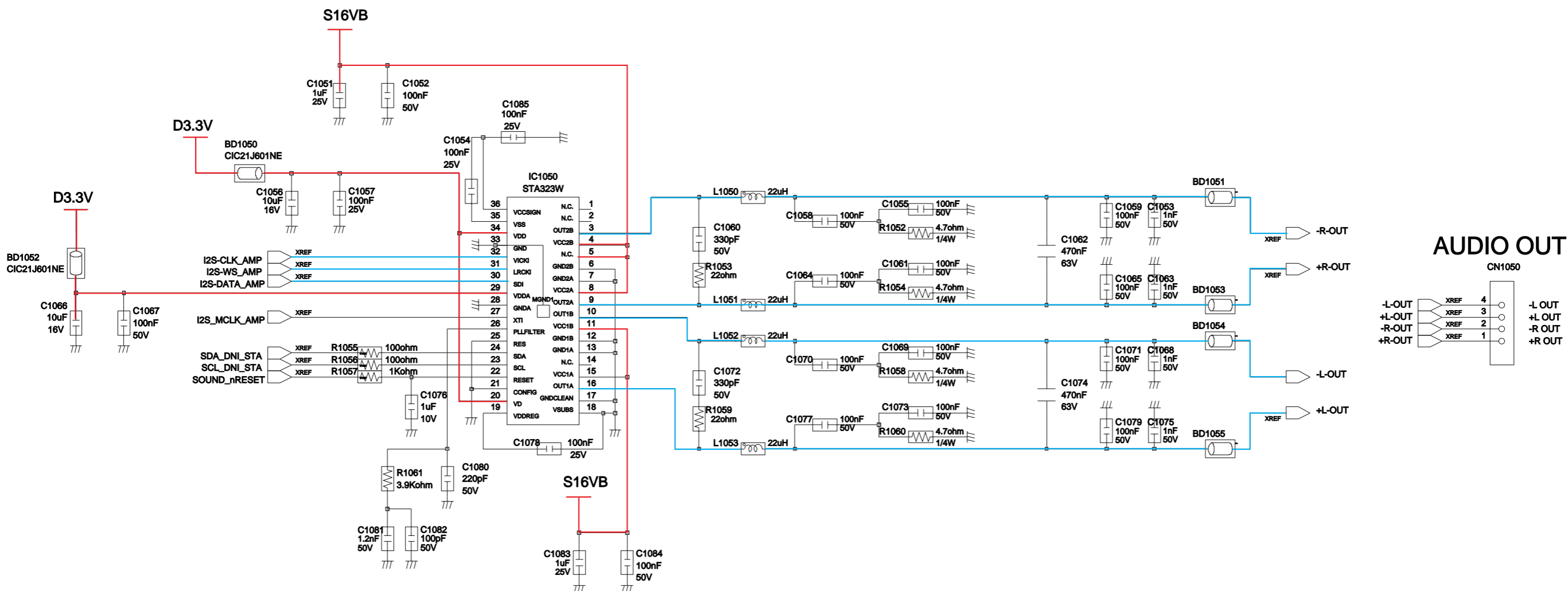
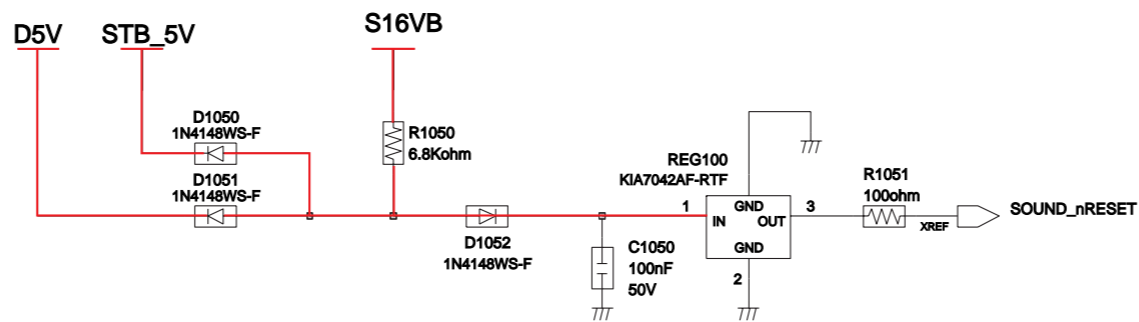
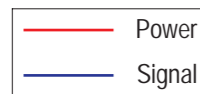

10-1-19 Main-19

This Document can not be used without Samsung's authorization.

Power Signal from SMPS Board

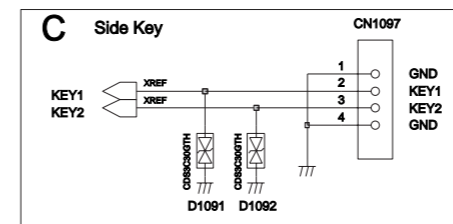
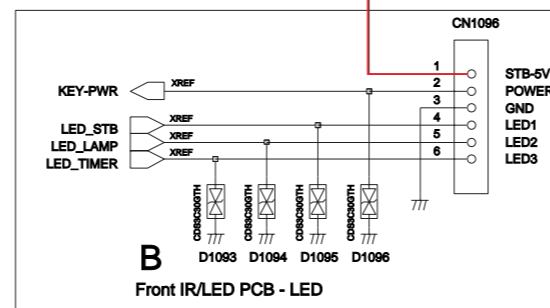
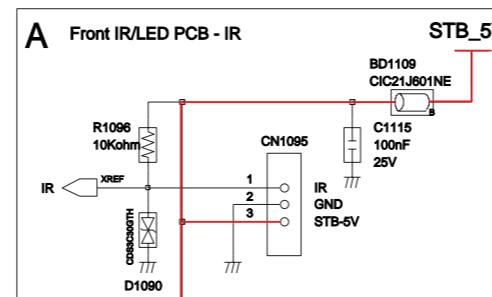
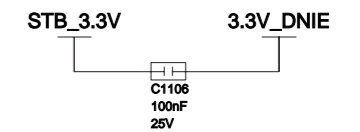
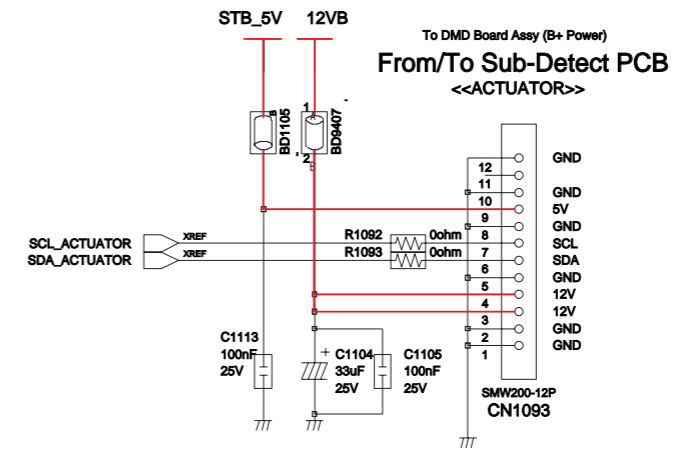
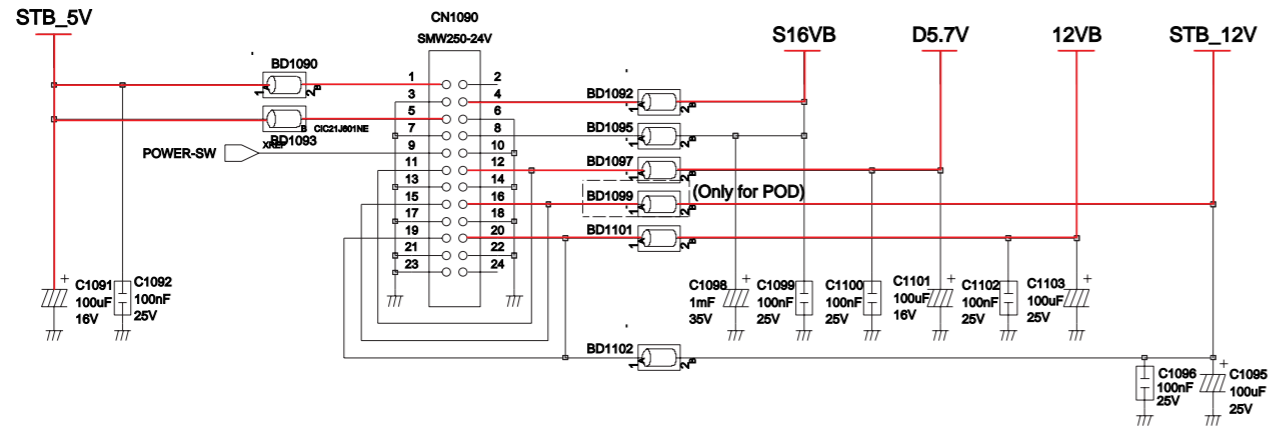
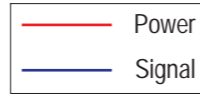

A	B	C	D
1. IR	1. 5VA	1. GND	1. LED1
2. GND	2. KEY-PWR	2. KEY1	2. KEY1
3. 5VA	3. GND	3. KEY2	3. KEY2
	4. LED1	4. GND	4. SDA-M1
	5. LED2		5. SCL-M1
	6. LED3		6. 5VB
			7. GND

Used as follows...

L3 : A+B, C
L5 : A, B, C
L7 : A, D

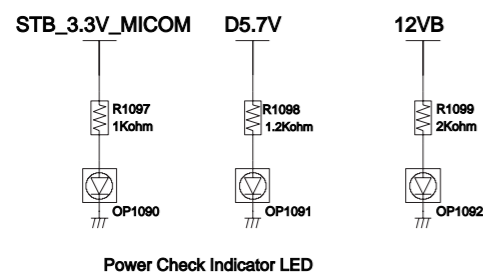

10-1-20 Main-20

This Document can not be used without Samsung's authorization.

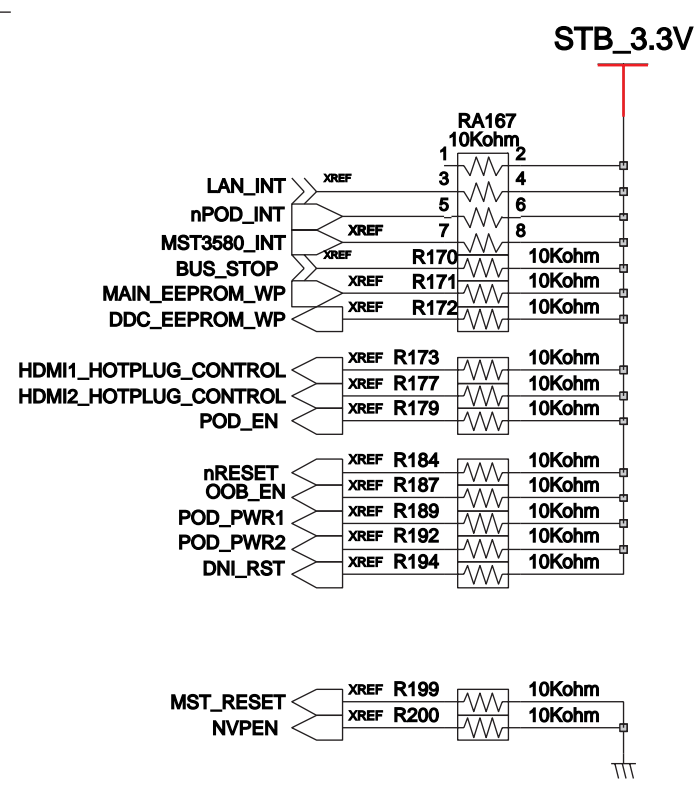
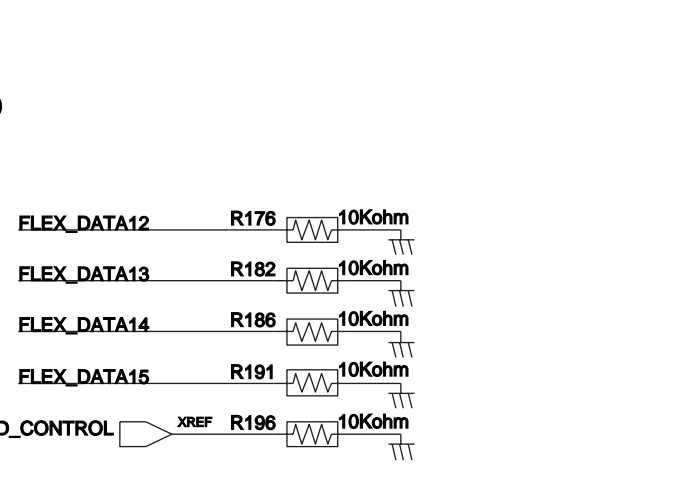
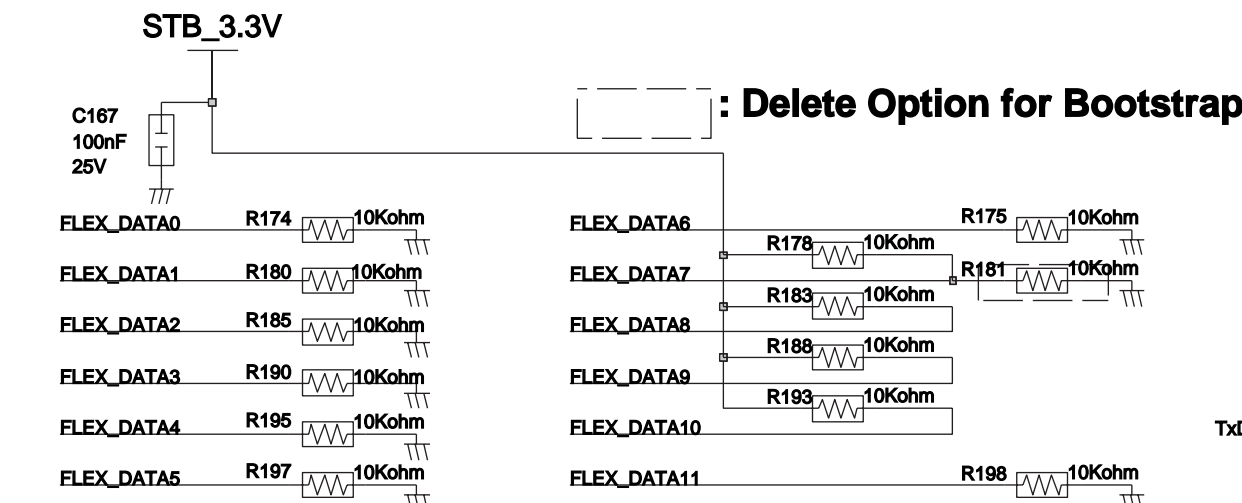
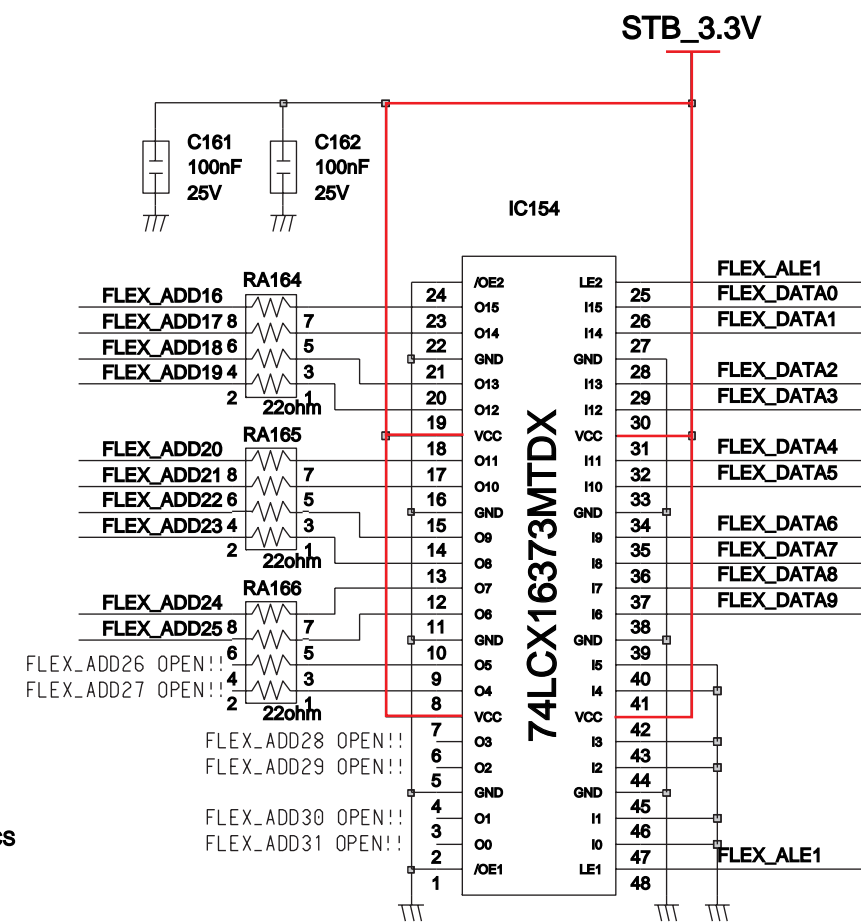
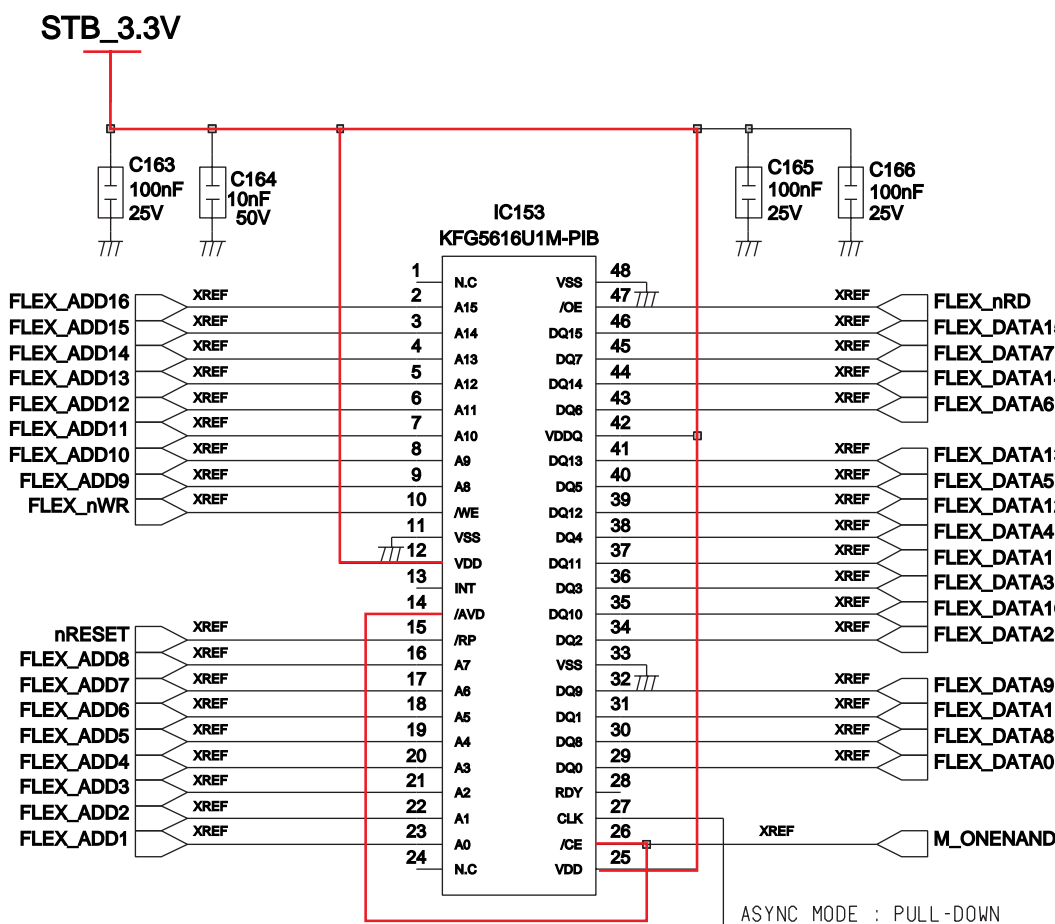
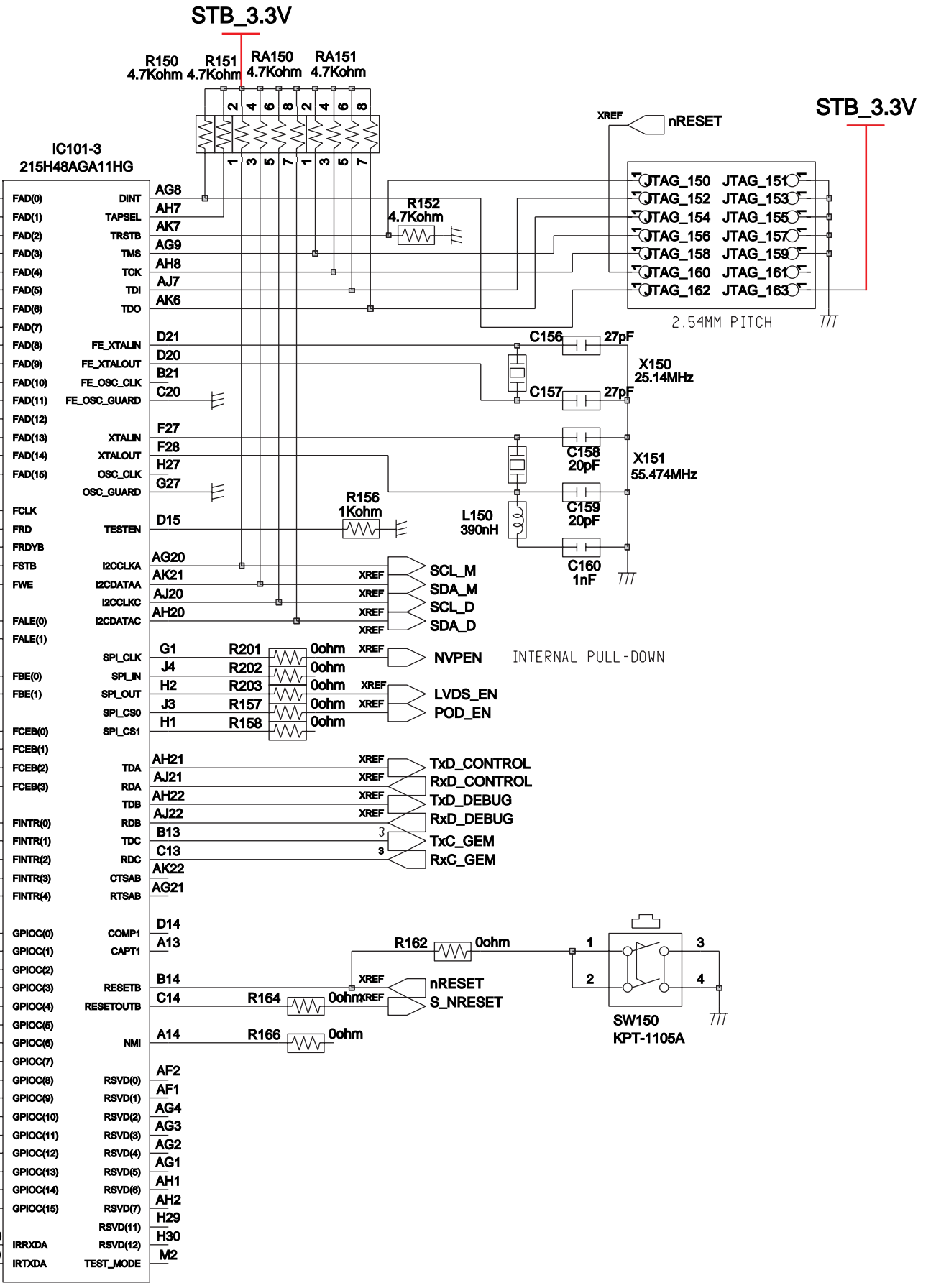
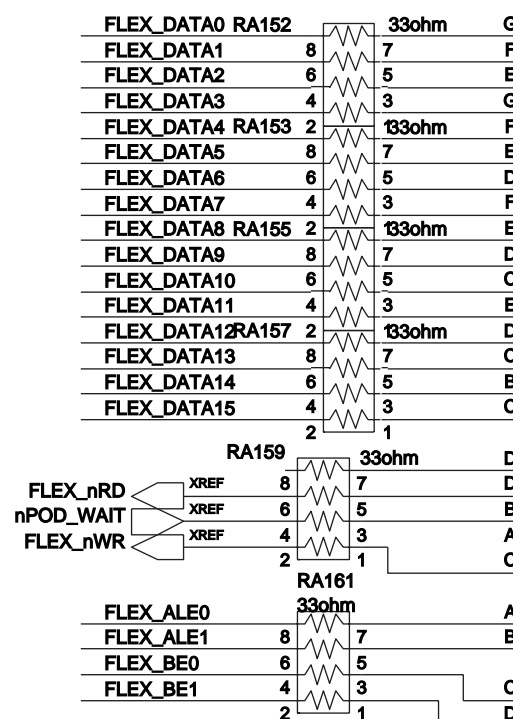
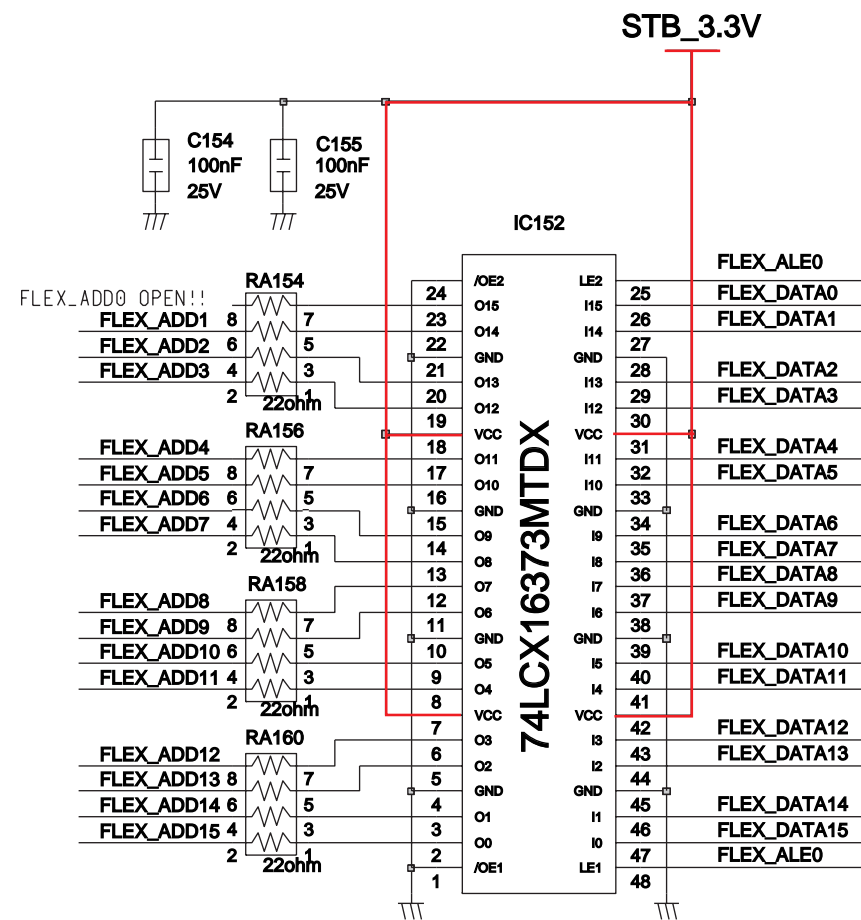
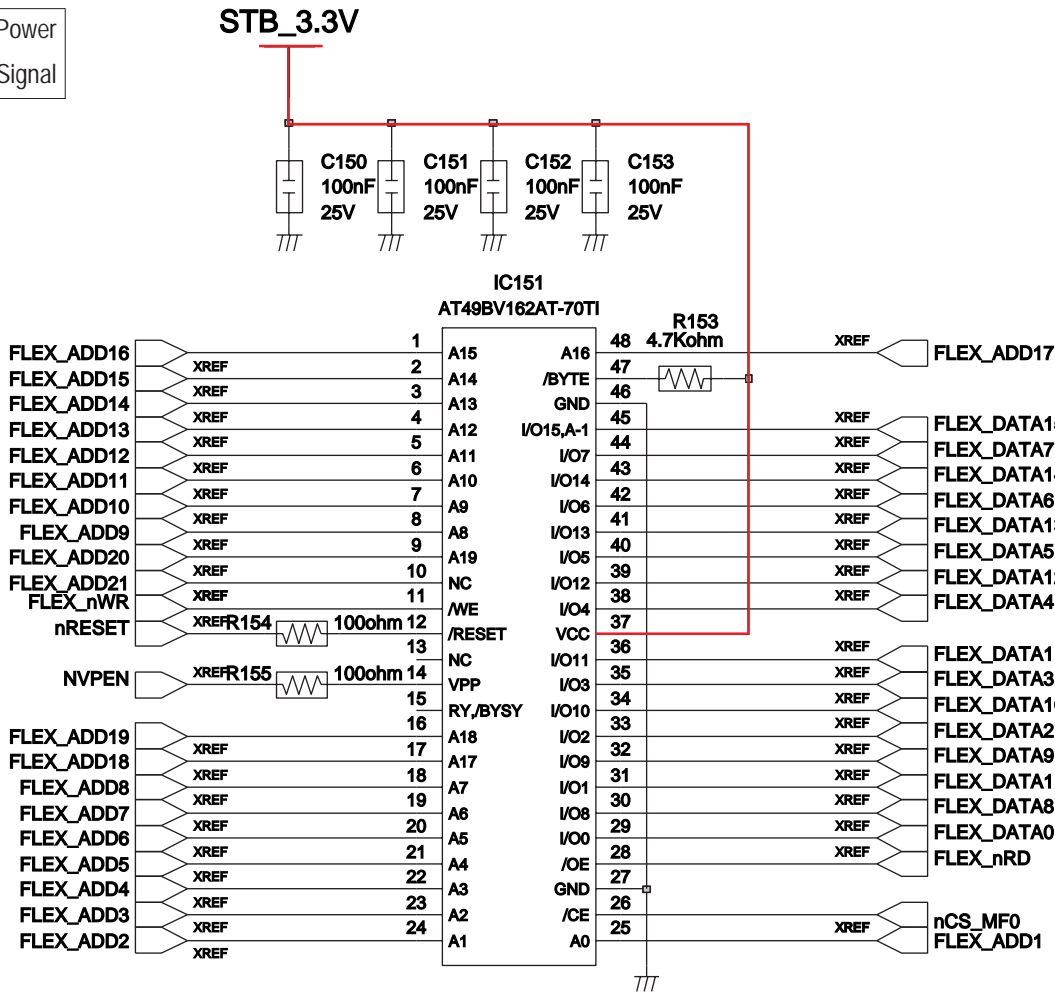
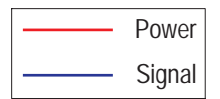

BUS_STOP for Debug

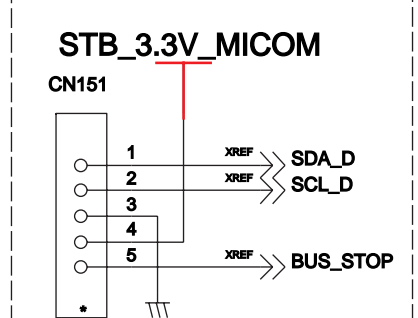
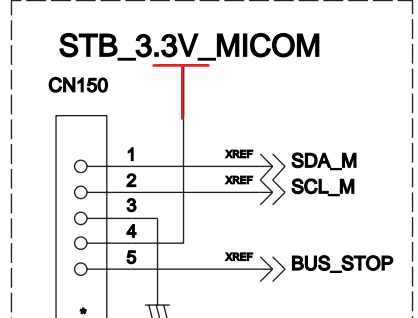

BOOT ROM ENABLE : FAD(0)
RESERVED - INTERNAL PULL DOWN. SHOULD BE "0" DURING RESET
SYSTEM CONFIGURATION : FAD(4:3)
00 - SOLO (DEFAULT)
01 - RESERVED
10 - RESERVED
11 - RESERVED
USE NO POWER SWITCHING : FAD(5)
0 - SET (DEFAULT)
1 - RESET
RESERVED FAD(6)
RESERVED - INTERNAL PULL DOWN. SHOULD BE "0" DURING RESET
FAD(10:7)
0000 - ST MICROELECTRONICS M25P40
0001 - 16-BIT, 512MBIT, 1GBIT NAND FLASH DEVICES
0010 - 8-BIT, 512MBIT, 1GBIT NAND FLASH DEVICES
0011 - 16-BIT, 32,64,128,256MBIT, 1GBIT NAND FLASH DEVICES
0100 - 8-BIT, 32,64,128,256MBIT, 1GBIT NAND FLASH DEVICES
0101 - RESERVED
0110 - RESERVED
0111 - ST MICROELECTRONICS M25P80
1000 - ST MICROELECTRONICS M25P10
1001 - ST MICROELECTRONICS M25P05
1010 - ST MICROELECTRONICS M25P20
1011 - NEXFLASH NX25E01
1100 - ATMEL AT25F1024
1101 - ST MICROELECTRONICS M25P40
1110 - BOOT ROM CONNECT TO FLEXBUS, 8-BIT (DEFAULT)
1111 - BOOT ROM CONNECT TO FLEXBUS, 16-BIT
FACTORY TEST : TDA
0 - NORMAL CHIP OPERATION (DEFAULT)
1 - FACTORY TEST A
DFE MODE : FAD(11)
0 - NORMAL CHIP OPERATION (DEFAULT)
1 - FACTORY TEST B
ID STRAP : FAD(15:12)

10-2 DMD Board

10-2-1 DMD Board-1

This Document can not be used without Samsung's authorization.

INPUT

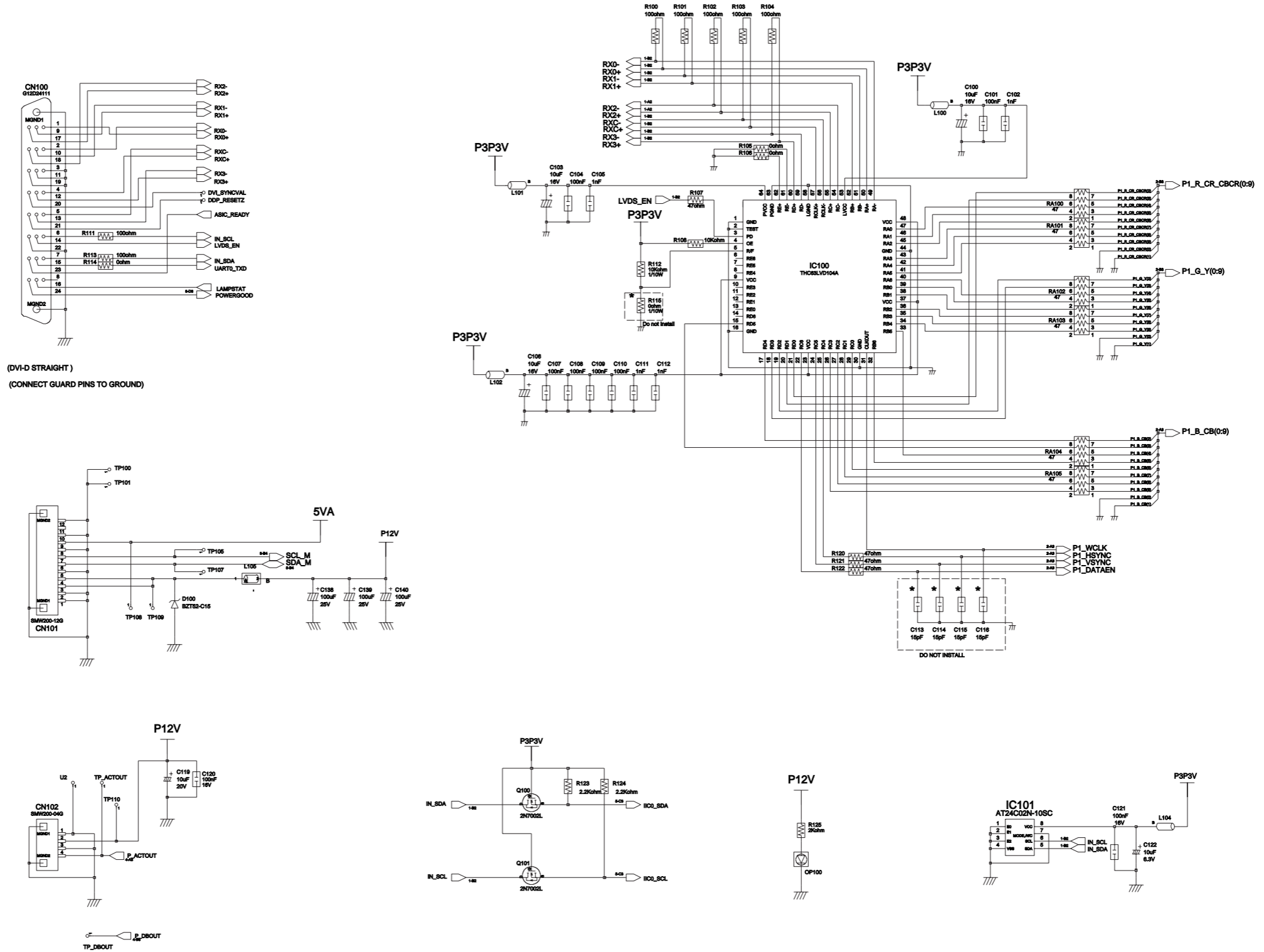

10-2-2 DMD Board-2

This Document can not be used without Samsung's authorization.

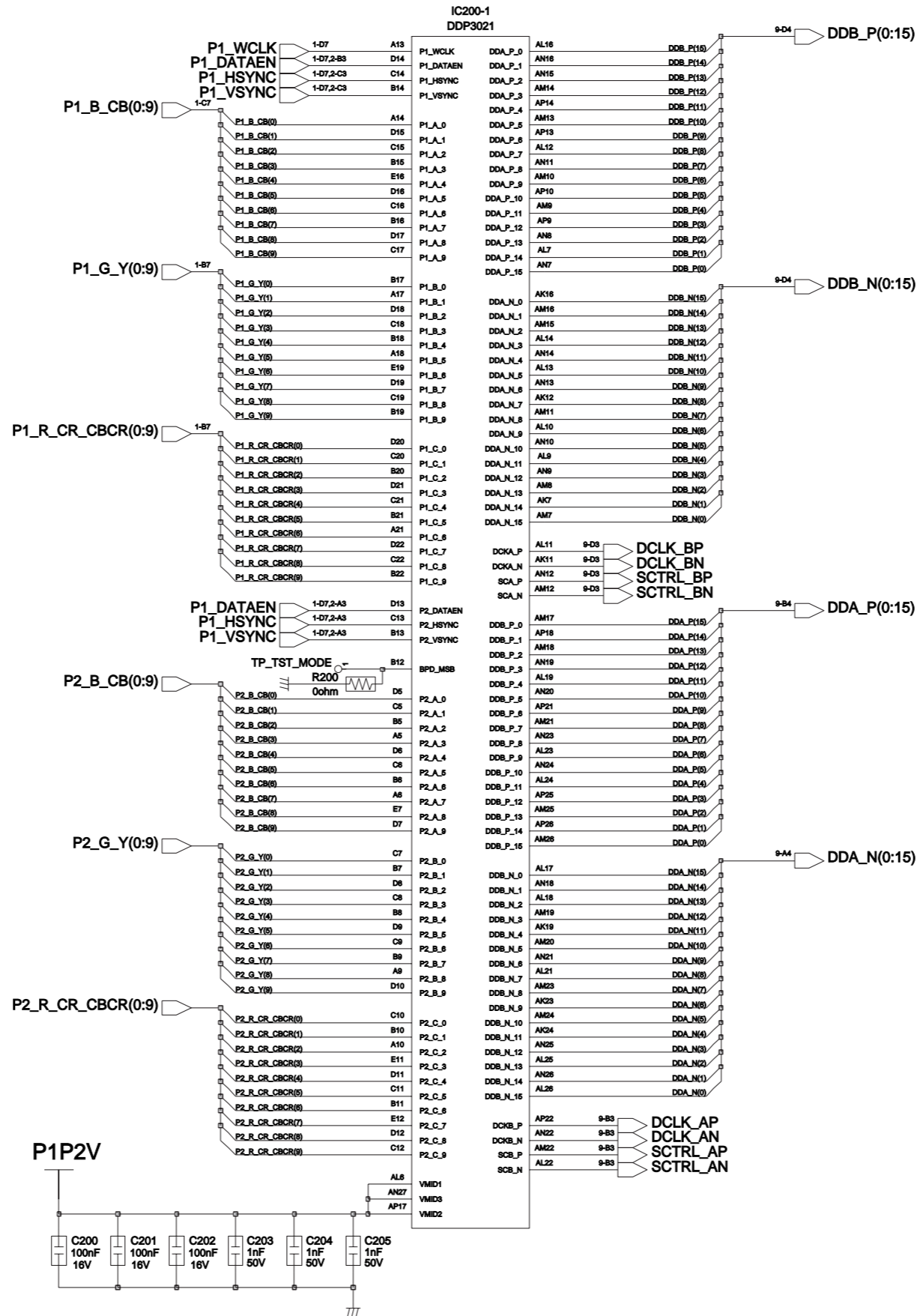

10-2-3 DMD Board-3

This Document can not be used without Samsung's authorization.

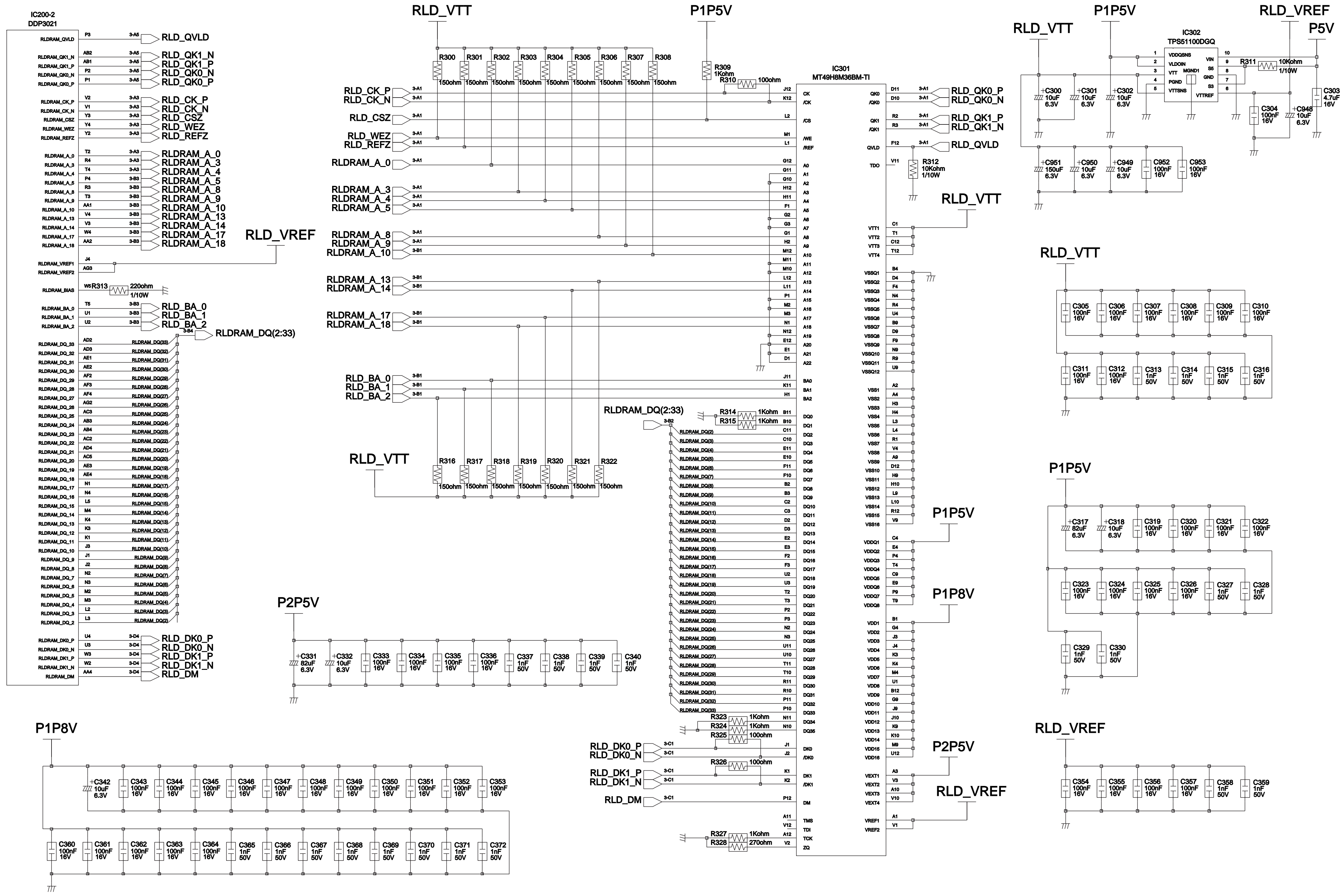

10-2-4 DMD Board-4

This Document can not be used without Samsung's authorization.

DAD2000

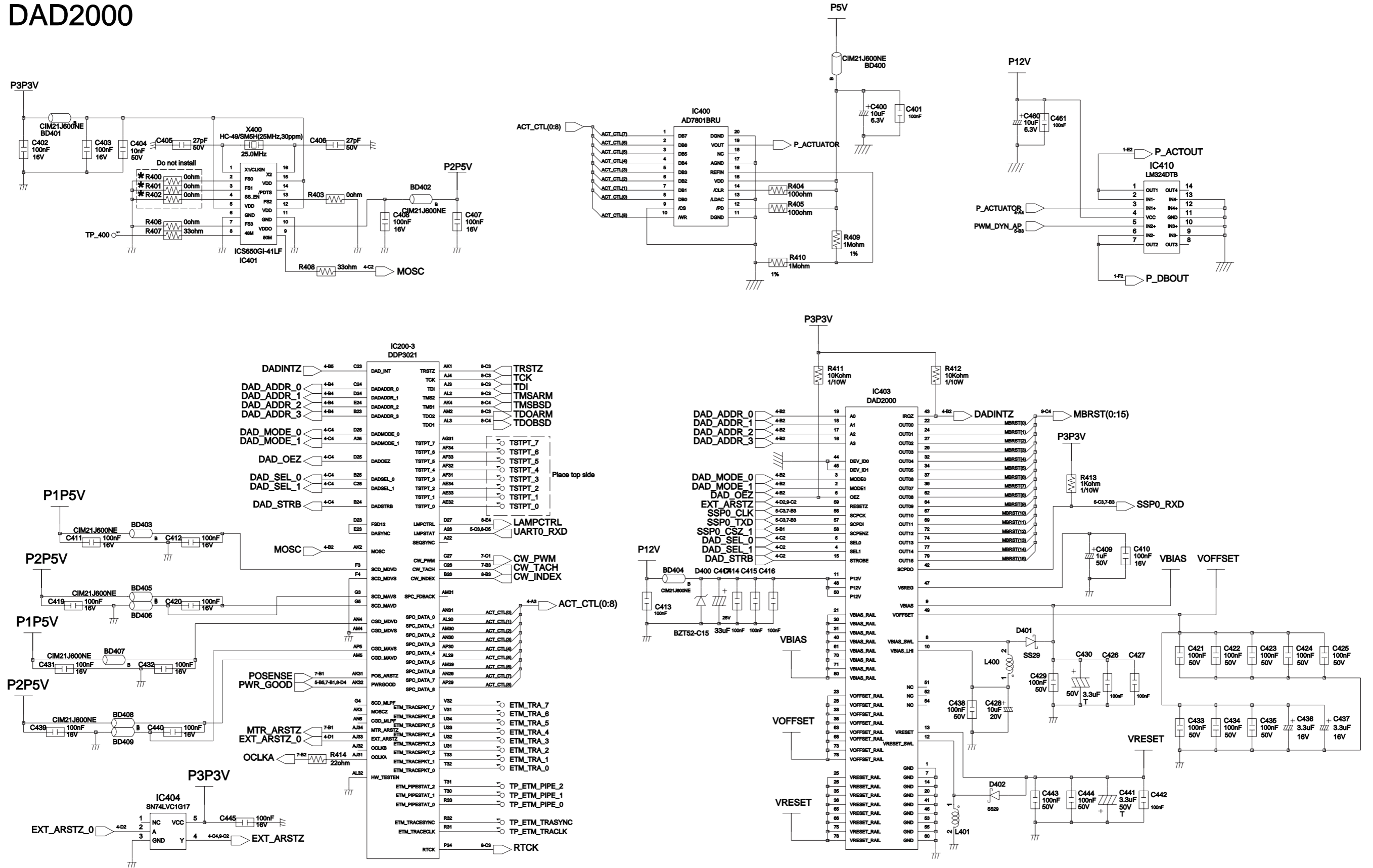

10-2-5 DMD Board-5

This Document can not be used without Samsung's authorization.

FLASH

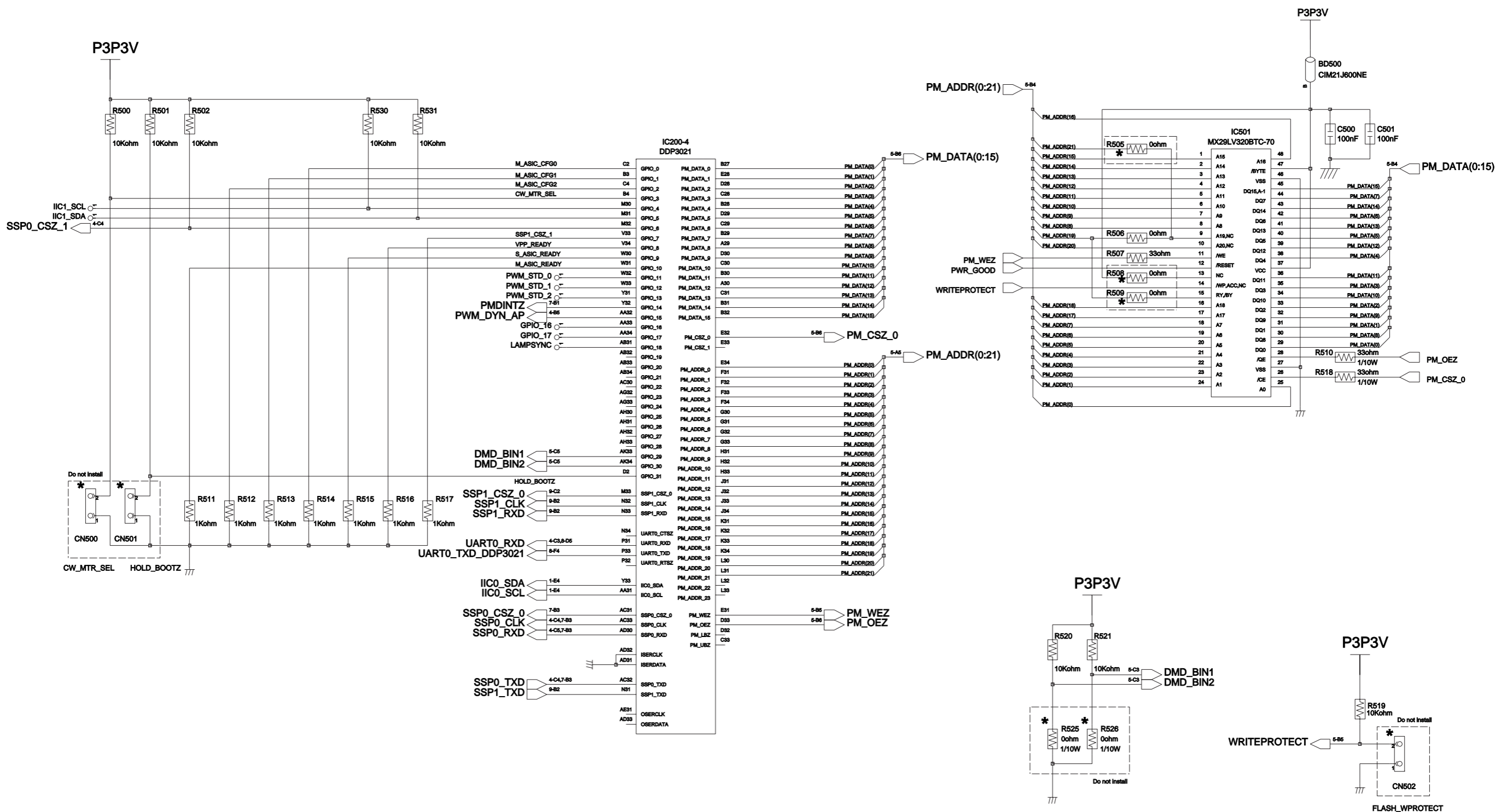

10-2-6 DMD Board-6

This Document can not be used without Samsung's authorization.

POWER

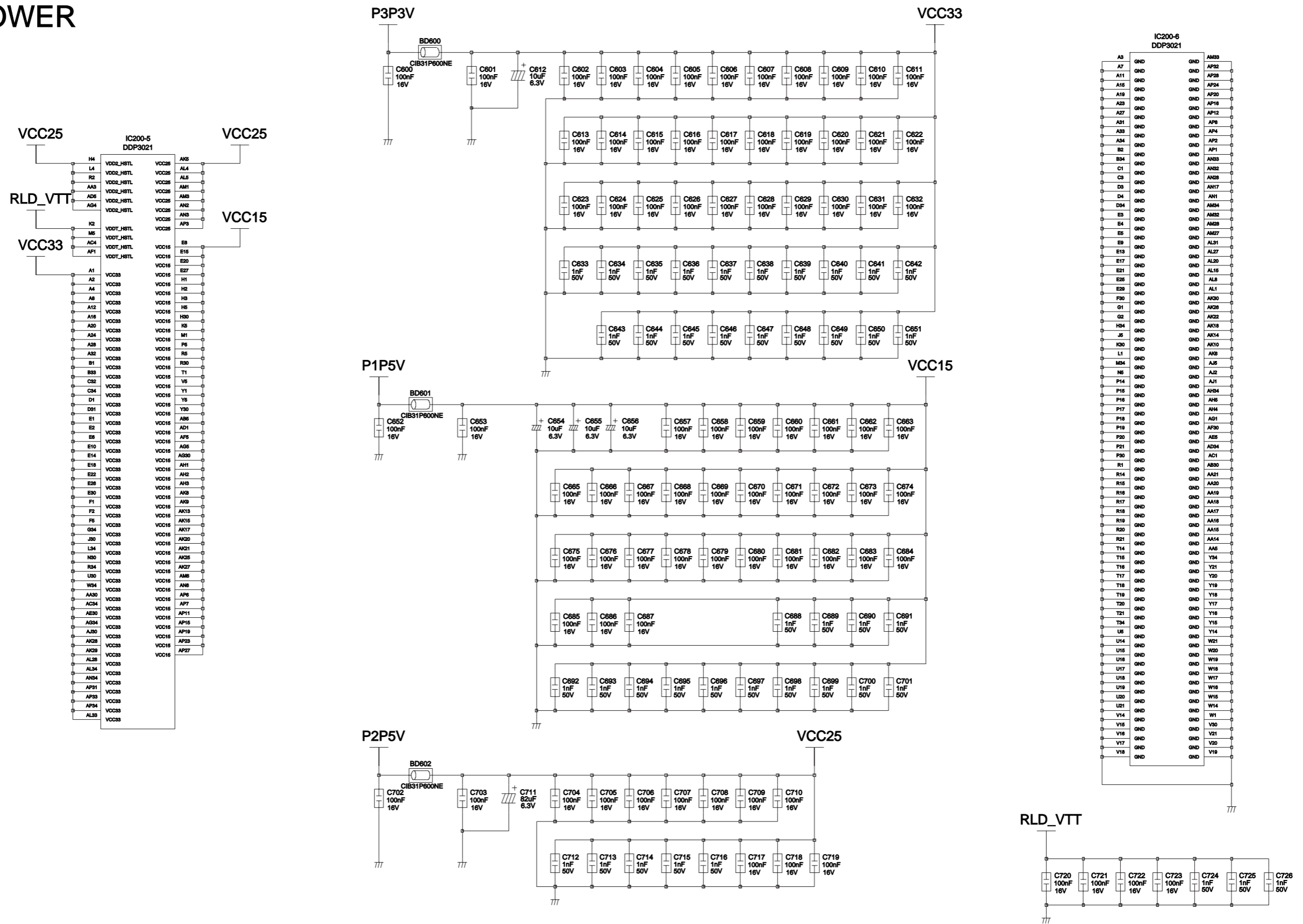

10-2-7 DMD Board-7

This Document can not be used without Samsung's authorization.

PMD1000

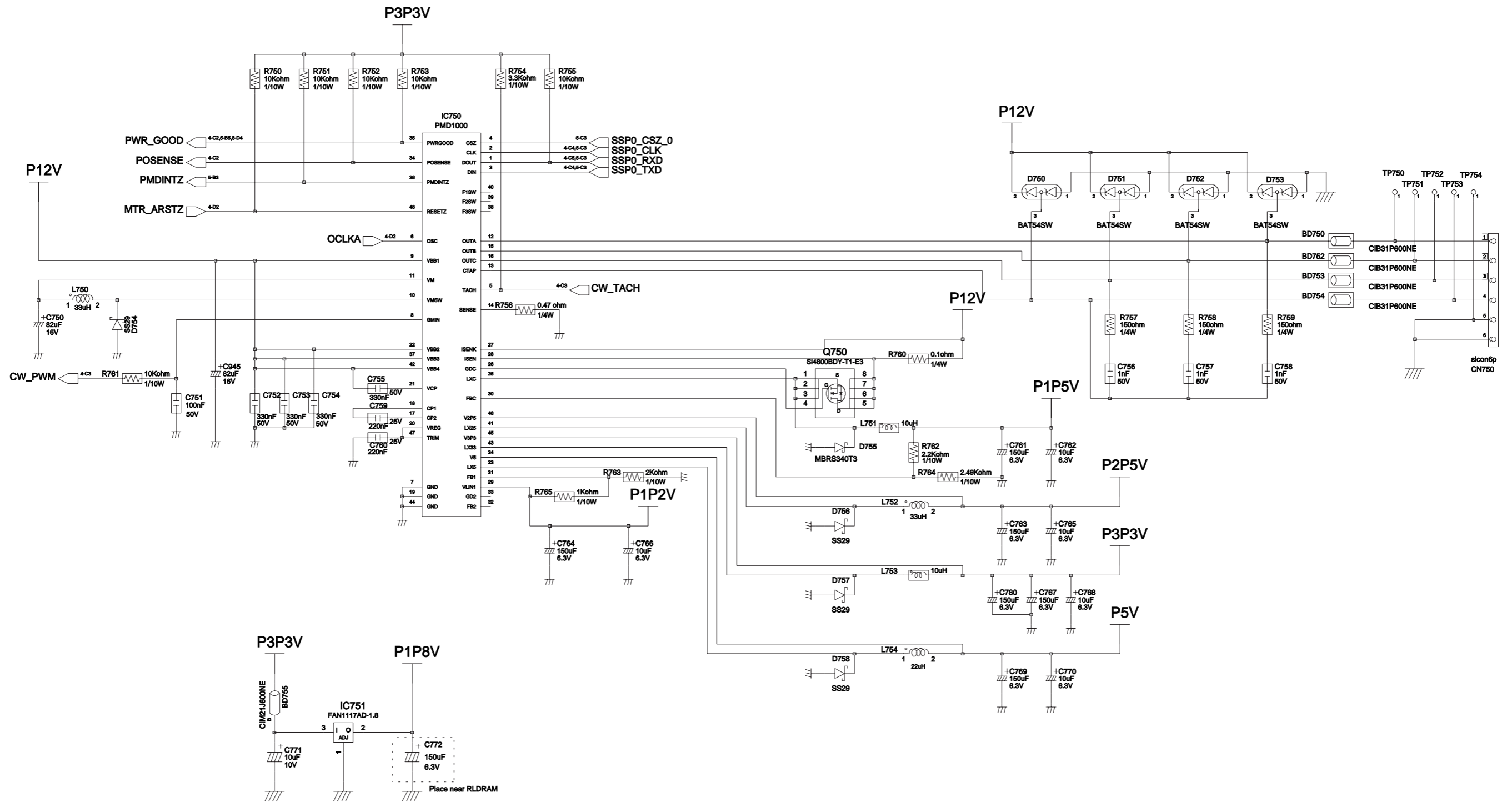

10-2-8 DMD Board-8

This Document can not be used without Samsung's authorization.

COLOR WHEEL SENSOR DETECTION

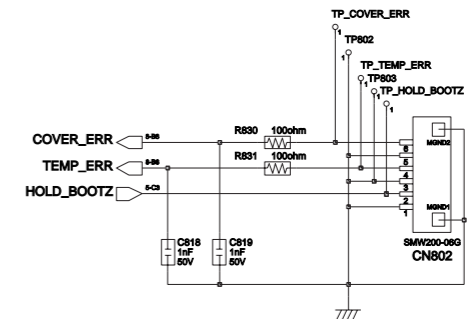
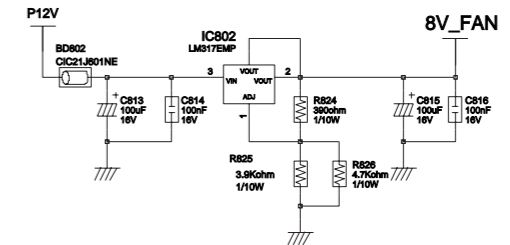
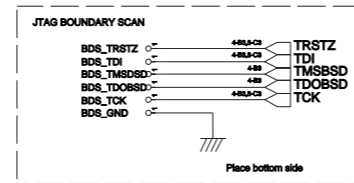
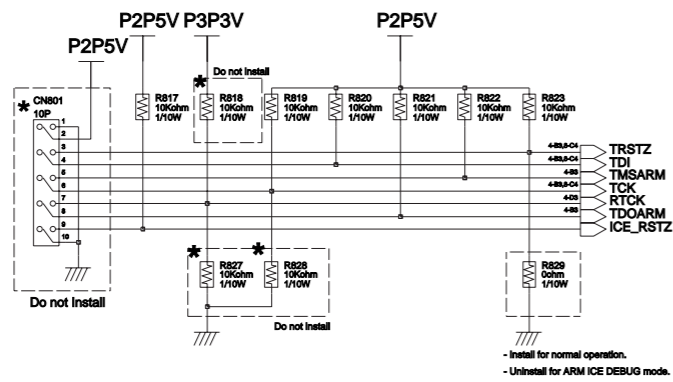
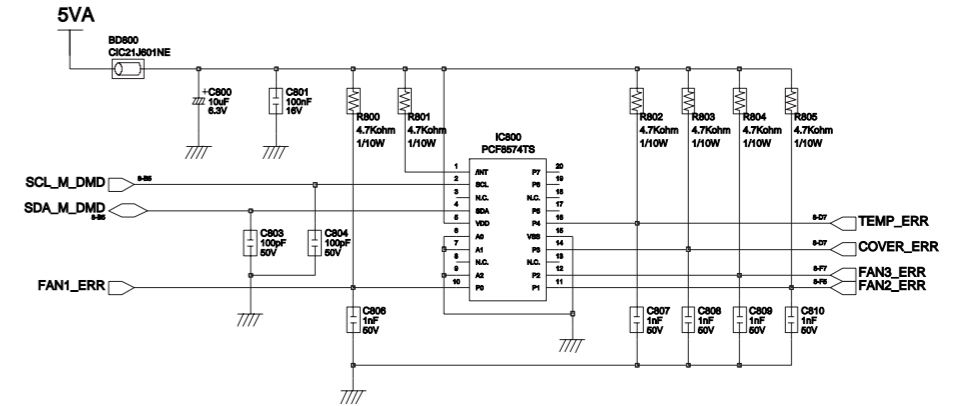
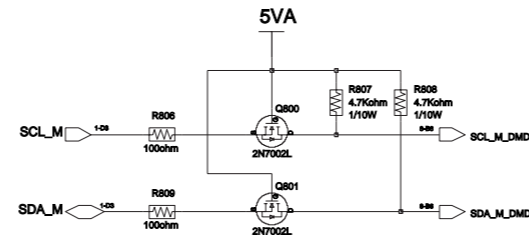
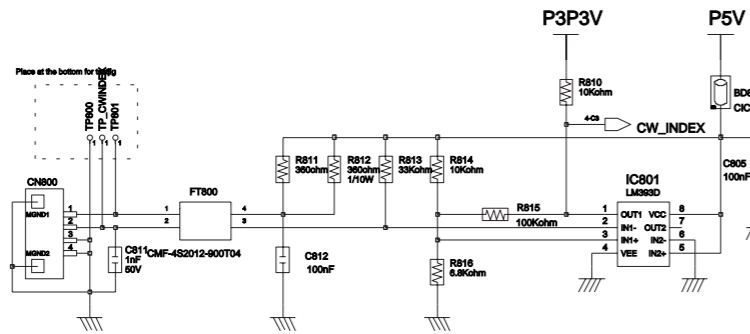

LAMP CONTROL

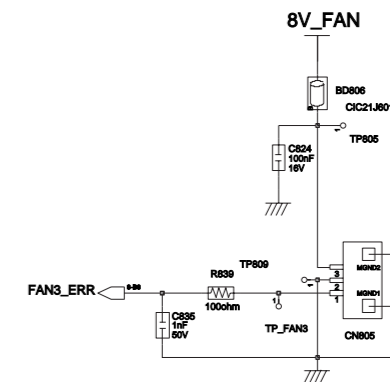
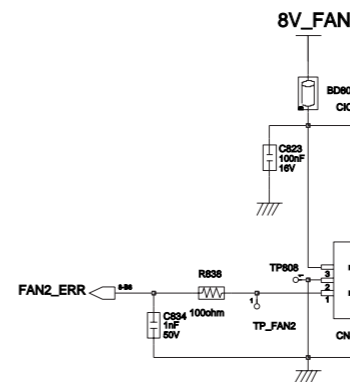
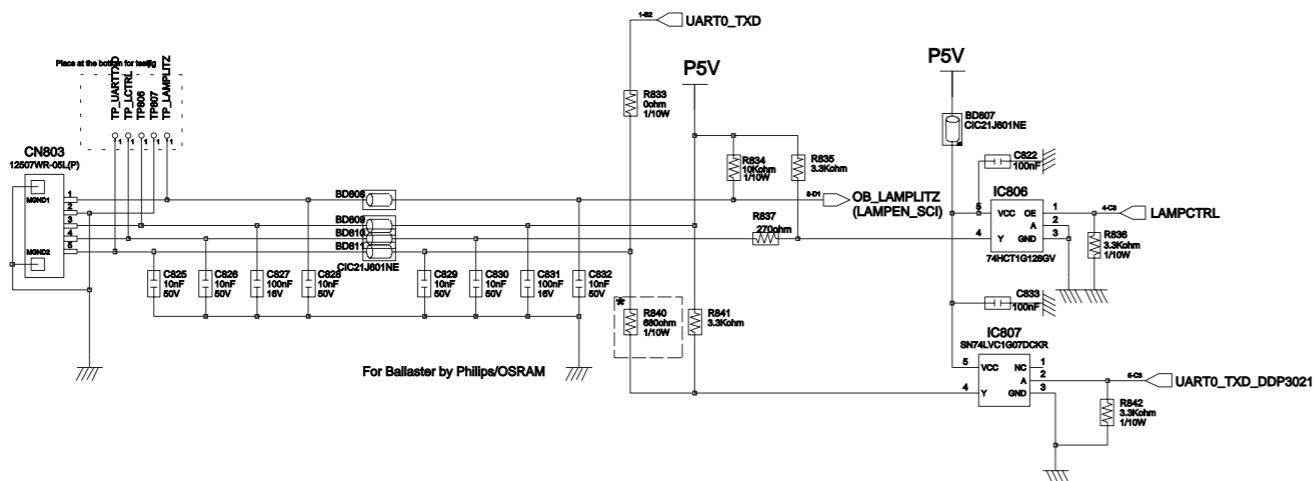
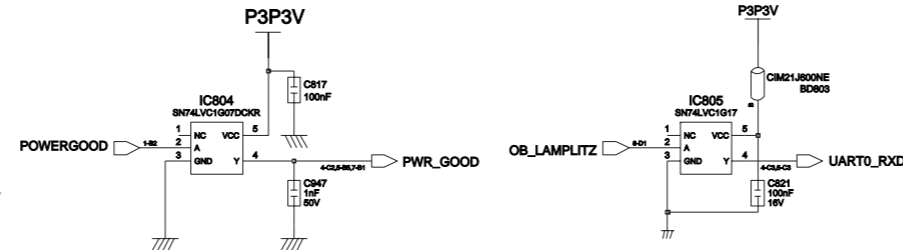
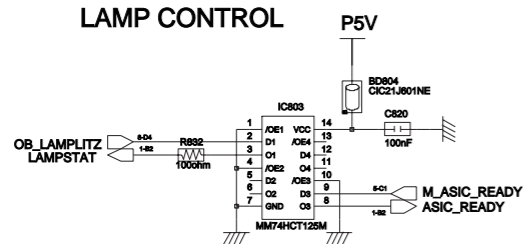

10-2-9 DMD Board-9

This Document can not be used without Samsung's authorization.

DMD Type_X

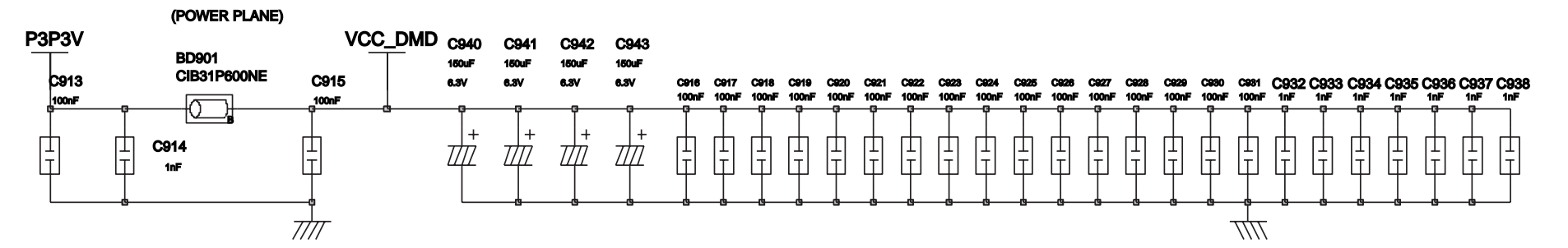
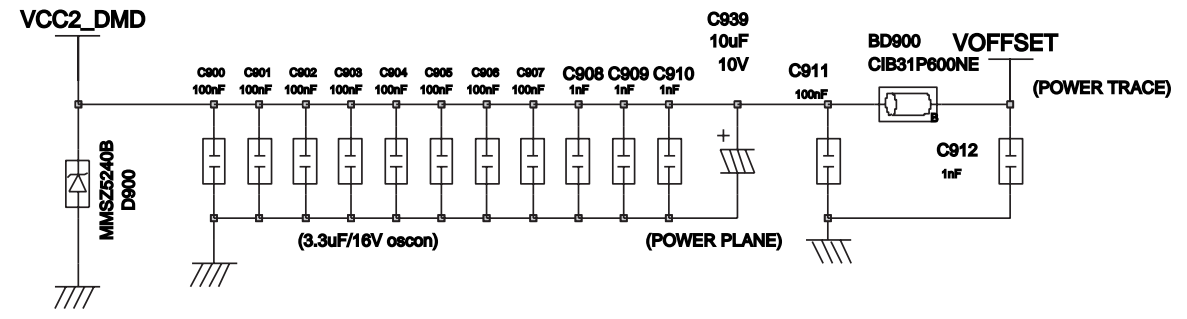
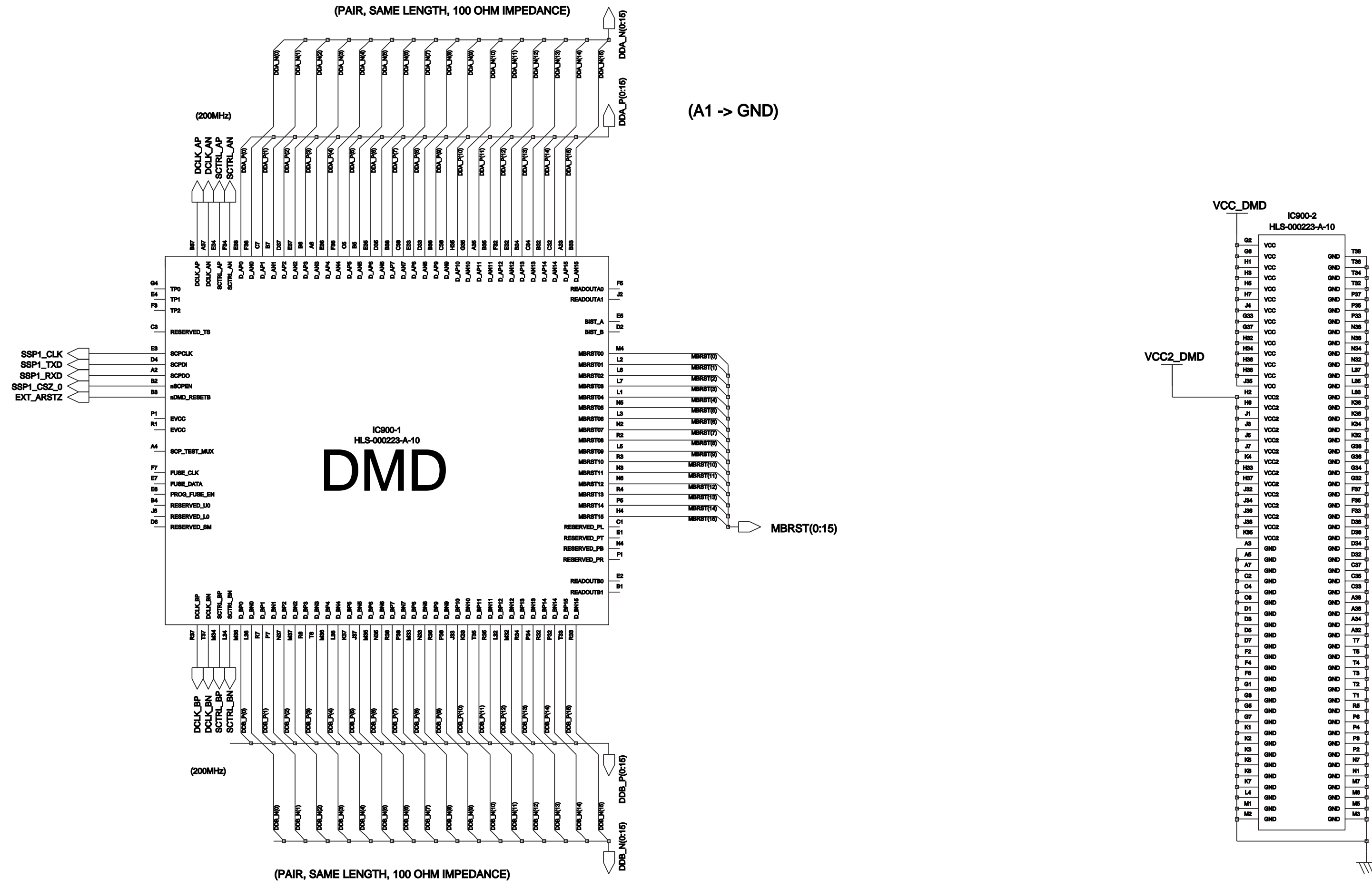

10-3 Power Board

This Document can not be used without Samsung's authorization.

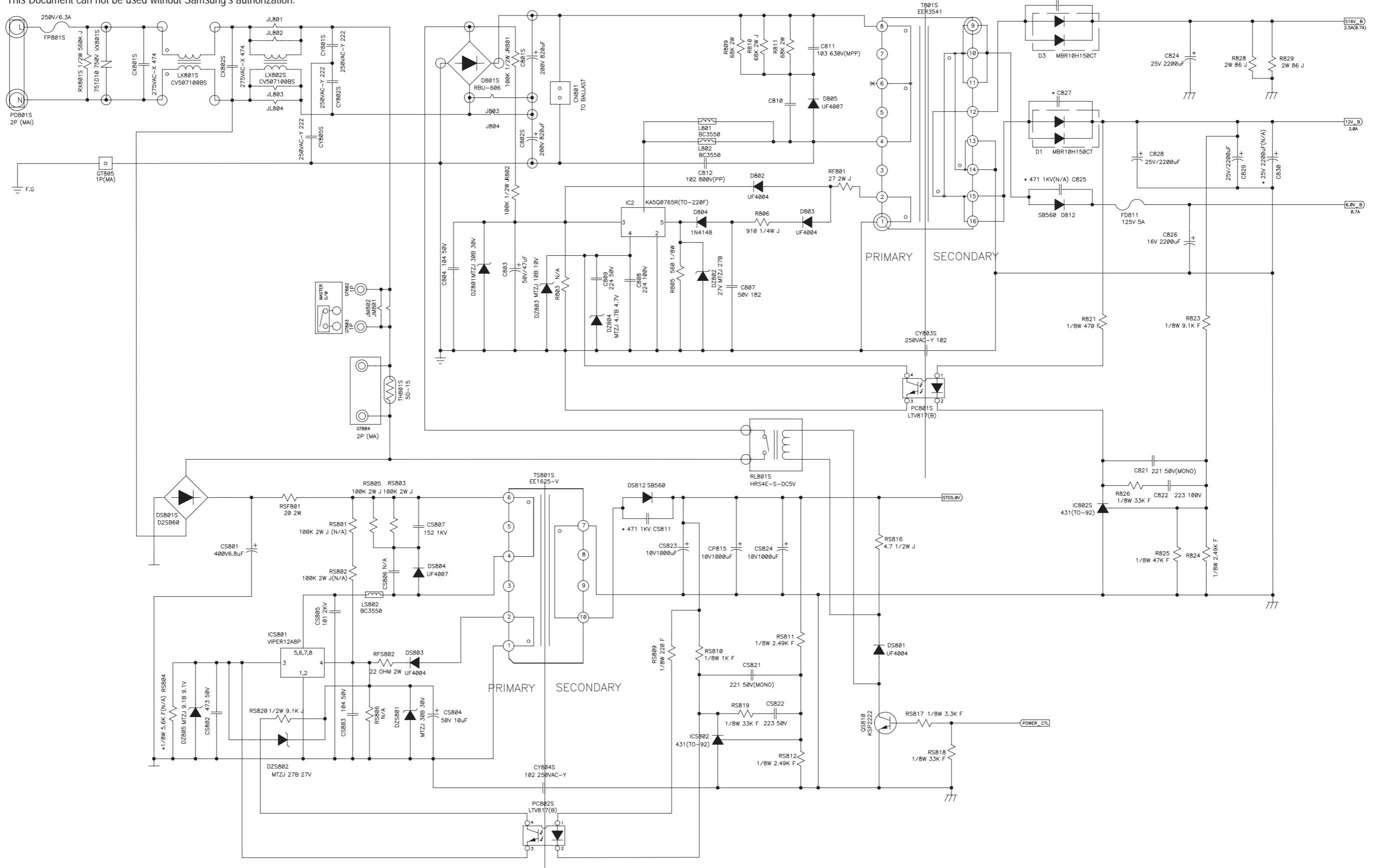

10-4 Key Control

This Document can not be used without Samsung's authorization.

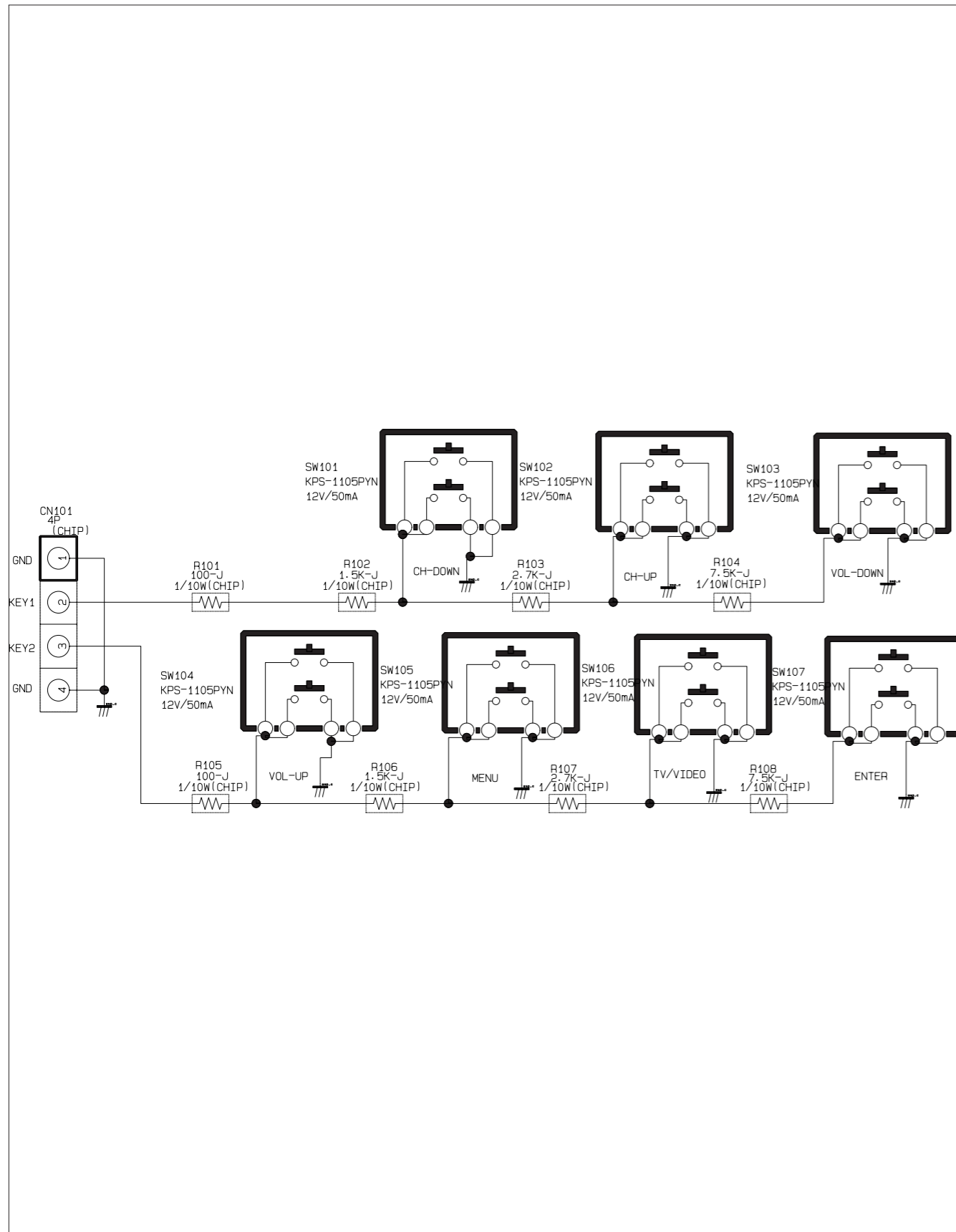

10-5 LED

This Document can not be used without Samsung's authorization.

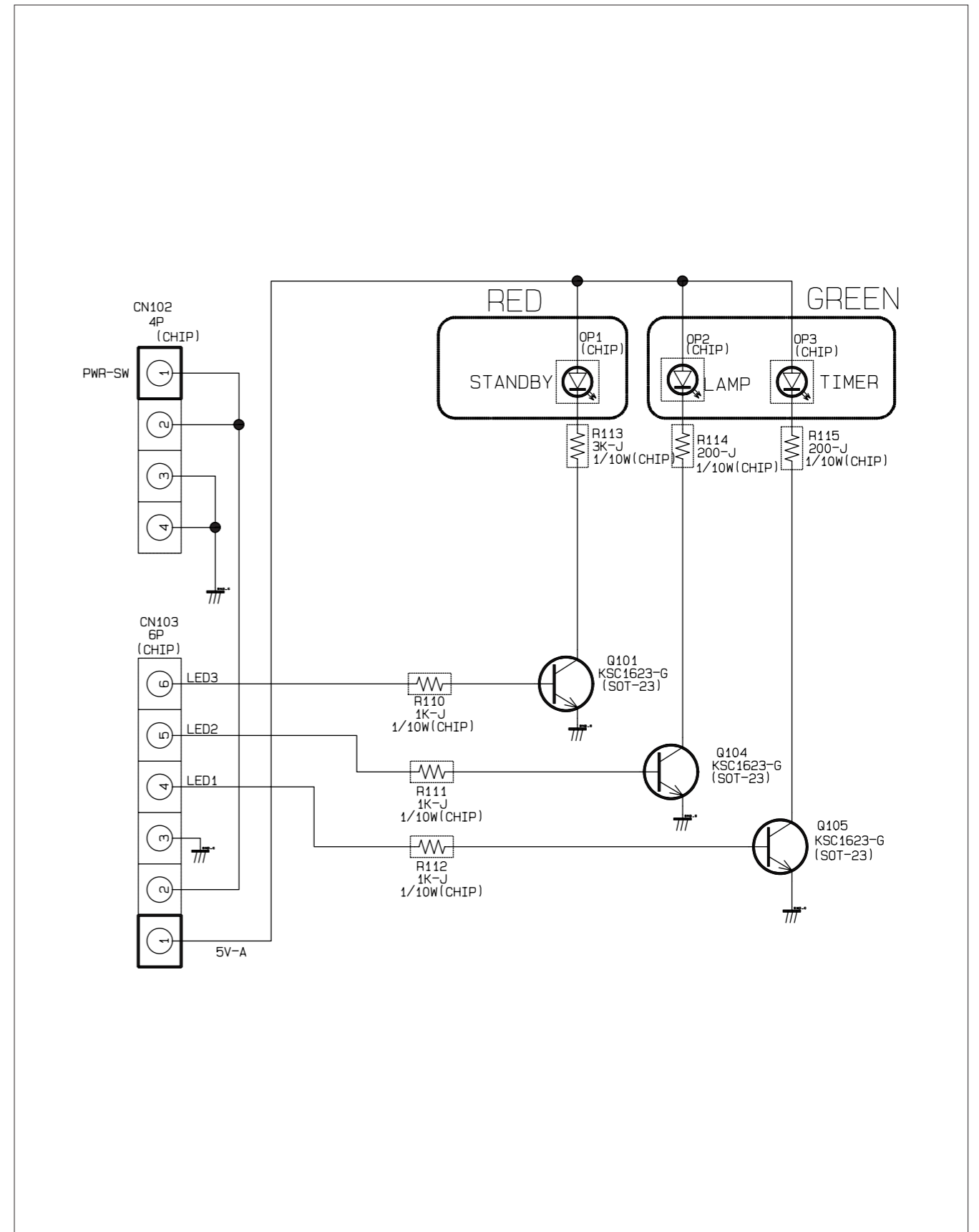

10-6 RMC

This Document can not be used without Samsung's authorization.

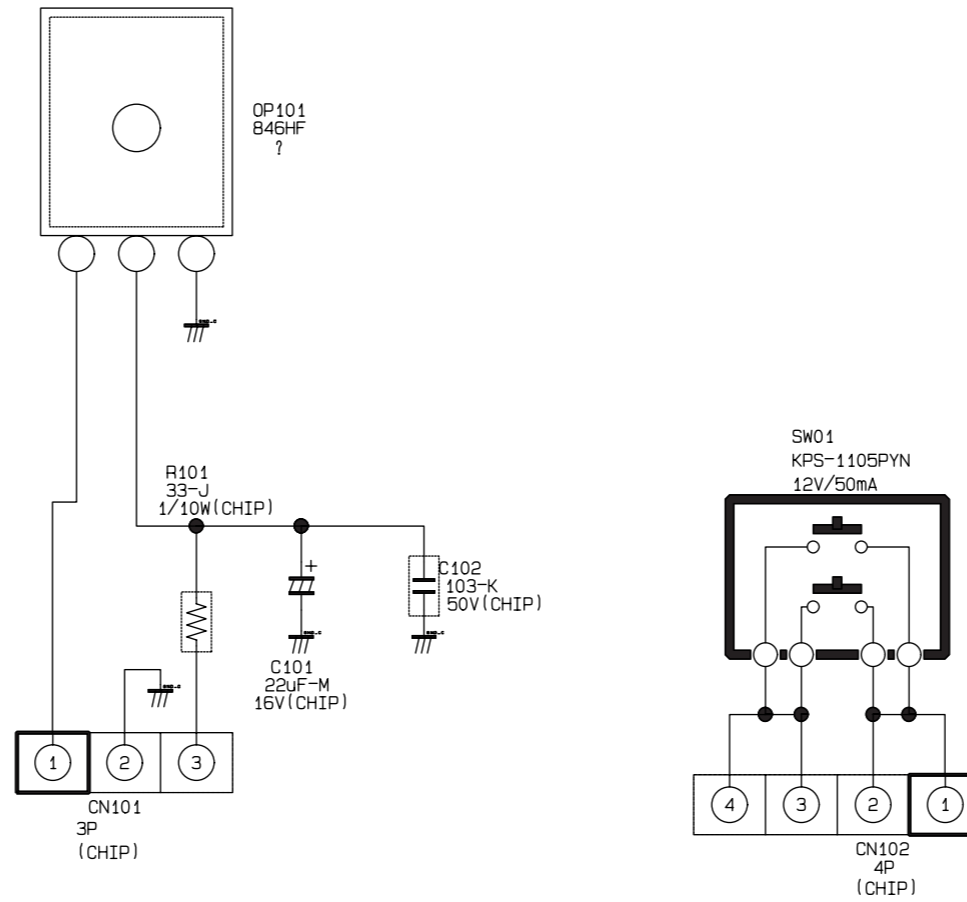

11. Operation Instruction & Installation

11-1 Product Features and Functions

11-1-1 Right side buttons

The buttons on the right side panel control your TV's basic features, including the on-screen menu system. To use the more advanced features, you must use the remote control. The product color and shape may vary depending on the model.

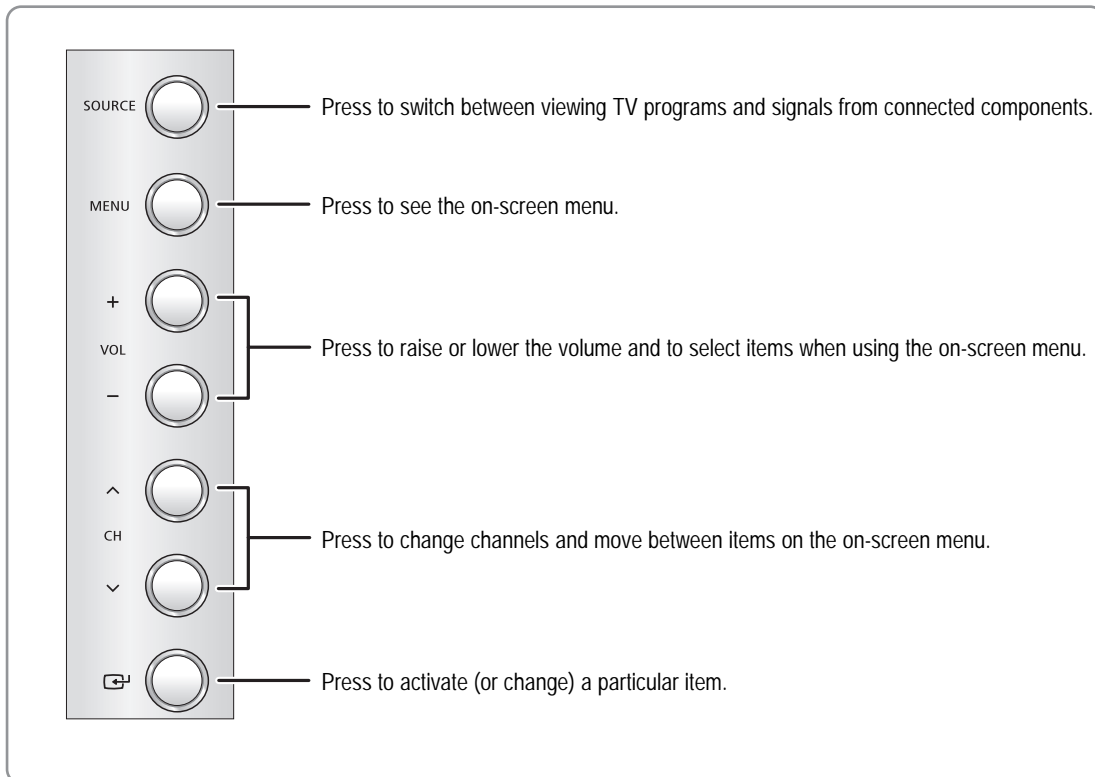

11-1-2 Front Panel LED Indicators

The three lights on the front panel indicate the status of your TV.

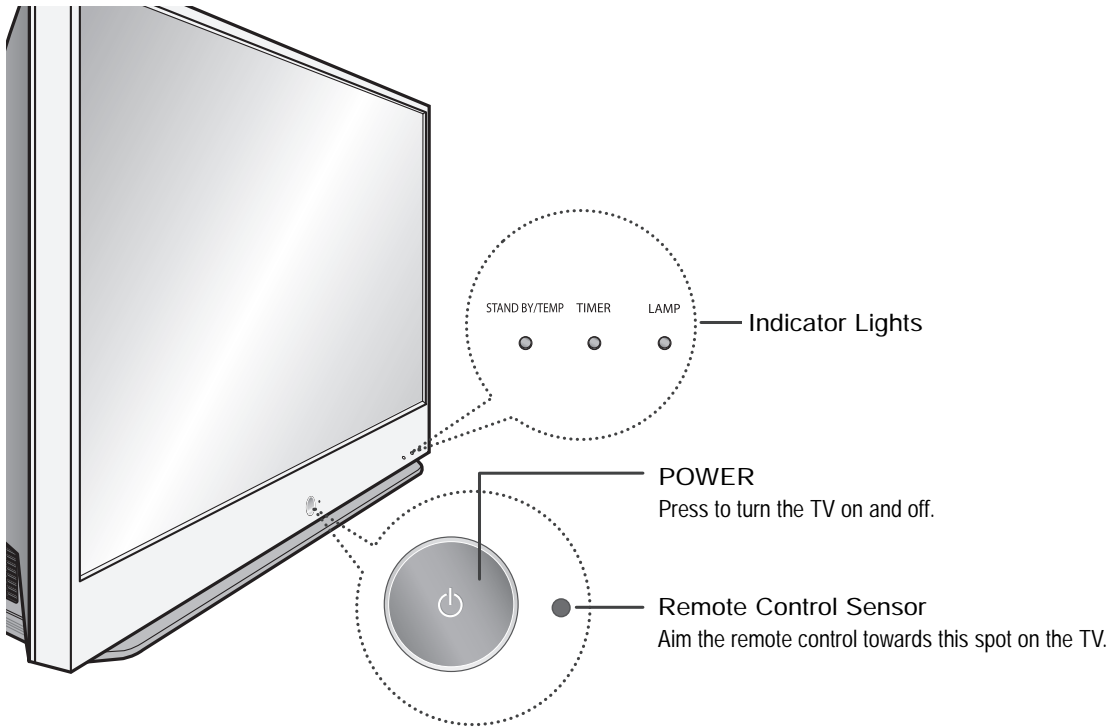

Indicator Light Key

- : Light is On
- ◐ : Light is Blinking
- : Light is Off

TIMER	LAMP	STAND BY/TEMP	Indication
○	○	●	Standby state.
○	◐	○	The picture will automatically appear in about 15 seconds.
●	◐	○	Auto Timer ON/OFF has been set and the set will automatically be turned on in about 25 seconds.
◐	○	◐	A cooling fan inside the set is not operating normally.
○	◐	◐	Lamp cover on the rear of the set is not properly shut.
○	○	◐	Check if the ventilation hole on the rear of the set is blocked, because if the inner temperature is too high, the power will shut off.
◐	◐	◐	Lamp may be defective. Please contact a certified technician.

- It takes about 30 seconds for the TV to warm up, so normal brightness may not appear immediately.
- The TV has a fan to keep the inside lamp from overheating. You'll occasionally hear it working.

11-1-3 Rear Panel Jacks

Use the rear panel jacks to connect components such as a VCR. You can connect different components such as VCRs, Set-Top Box and a DVD player etc., because there are two sets of video input jacks and two sets of component video input jacks on the rear panel of your TV. For more information, see "Connections".

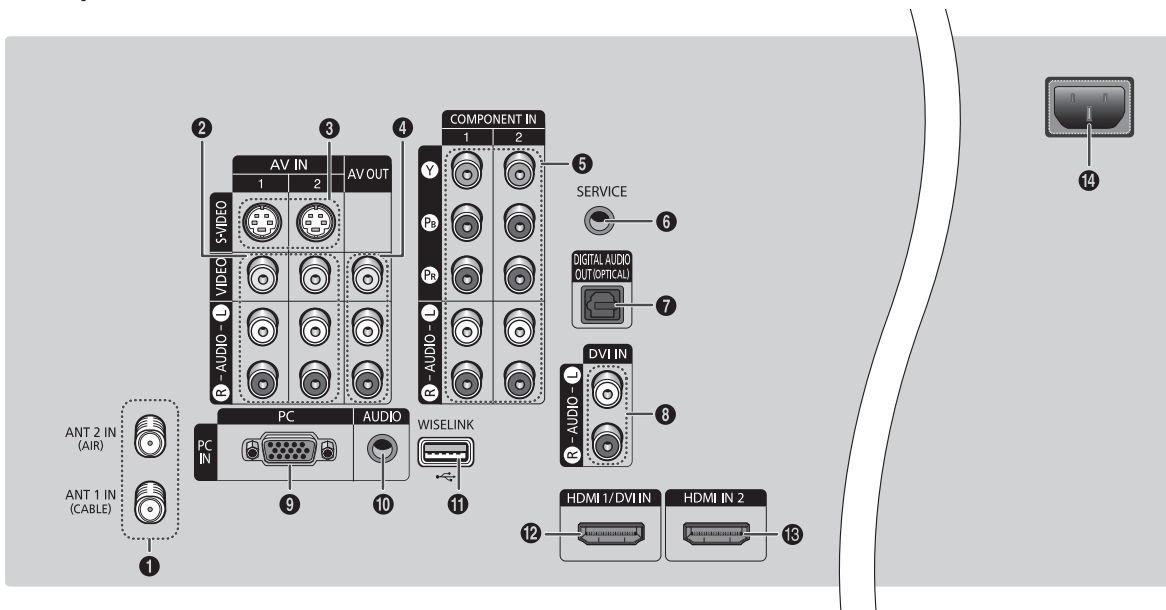

- ① **ANTENNA terminals**
Two independent cables or antennas can be connected to these terminals. Use "ANT 1 IN (CABLE)" and "ANT 2 IN (AIR)" terminals to receive a signal from VHF/UHF antennas or your cable system.
- ② **VIDEO/AUDIO input jacks**
Connect video/audio signals from external sources, such as VCR or DVD players.
- ③ **S-VIDEO input jacks**
Connects an S-Video signal from an S-VHS VCR or DVD player.
- ④ **VIDEO/AUDIO output jacks**
Sends video/audio signals from the TV to an external source, such as a VCR. These jacks are available only in TV, Video and S-Video modes.
- ⑤ **COMPONENT IN 1, 2 jacks (Y, PB, PR, AUDIO L/R)**
Use these jacks to connect the component video/audio signals from a DVD player or a Set-Top Box.
- ⑥ **SERVICE**
This jack is for service only.
- ⑦ **DIGITAL AUDIO OUT (OPTICAL) jack**
Connect to a Digital Audio Component.
- ⑧ **DVI (Digital Video Interface) AUDIO input jacks**
Connect to the digital audio output jacks of a device with DVI output.
- ⑨ **PC VIDEO Input jack**
Connect these to the video output jack on your PC.
- ⑩ **PC AUDIO Input jack**
Connect these to the audio output jack on your PC.
- ⑪ **WISELINK**
You can connect a USB mass storage device to view photo files (JPEG) and play audio files (MP3).
- ⑫ **HDMI (High Definition Multimedia Interface) Input jack (HDMI 1/DVI IN)**
Connect to the HDMI jack of a device with HDMI output.
- ⑬ **HDMI (High Definition Multimedia Interface)/ DVI Input jack (HDMI IN 2)**
Connect to the HDMI jack of a device with HDMI output. This input can also be used as a DVI connection with separate analog audio inputs. An optional HDMI/DVI cable will be necessary to make this connection. When using the optional HDMI/DVI adapter, the DVI analog audio inputs on your TV allow you to receive left and right audio from your DVI device. (Not compatible with PC)
- ⑭ **POWER IN**
Connect the supplied power cord.

11-1-4 Remote Control

You can use the remote control up to about 23 feet from the TV. When using the remote control, always point it directly at the TV. You can also use your remote control to operate your VCR, Cable box, DVD player or Samsung Set-Top Box.

- | | |
|--|---|
| <ol style="list-style-type: none"> 1. POWER
Turns the TV on and off. 2. Channel Number
Press to directly tune to a particular channel. 3. -
Press to select additional channels (digital and analog) being broadcast by the same station. For example, to select channel "54-3", press "54", then press "-" and "3". 4. ANTENNA
Press to select "AIR" or "CABLE". 5. CH MGR
Used to displays Channel Lists on the screen. 6. VCR/DVD Controls
Controls VCR or DVD functions: Rewind, Stop, Play/Pause, Fast Forward. 7. VOL +, VOL -
Press to increase or decrease the volume. 8. MUTE
Press to mute the TV sound. 9. MENU
Displays the main on-screen menu. 10. ▲, ▼, ◀, ▶, ENTER
Press to select highlight up, down, left, or right. While using the on-screen menus, press ENTER to activate (or change) a particular item. 11. INFO
Press to display information on the TV screen. 12. CAPTION
Controls the caption decoder. 13. P.MODE
Adjust the TV picture by selecting one of the preset factory settings (or select your personal, customized picture settings.) 14. S.MODE
Select Sound effect. 15. MTS (Multichannel Television Stereo)
Press to choose Stereo, Mono or SAP (Secondary Audio Program). 16. SRS
Activates TruSurround. | <ol style="list-style-type: none"> 17. Mode (TV/DVD/STB/CABLE/VCR)
Selects a target device to be controlled by the Samsung remote control (i.e., TV, DVD, STB, CABLE, or VCR). 18. SOURCE
Press to display all of the available video sources (TV, AV1, AV2, S-Video1, S-Video2, Component1, Component2, PC, HDMI1, and HDMI2). 19. PRE-CH
Tunes to the previous channel. 20. WISELINK
This function enables you to view and play photo (JPEG) and audio files (MP3) from an external device. 21. FAV.CH (Favorite Channel)
Press to switch between your favorite channels. 22. CH ▲/▼
Press to change channels. 23. EXIT
Press to exit the menu. 24. SLEEP
Press to select a preset time interval for automatic shut off. 25. P.SIZE
Press to change the screen size. 26. STILL
Press to pause the current screen. 27. RESET
If your remote control is not functioning properly, take out the batteries and press the reset button for about 2-3 seconds. Re-insert the batteries and try using the remote control again. 28. SET
Used during set up of this remote control, so that it will work compatibly with other devices (Set-top box, VCR, Cable box, DVD, etc.) |
|--|---|

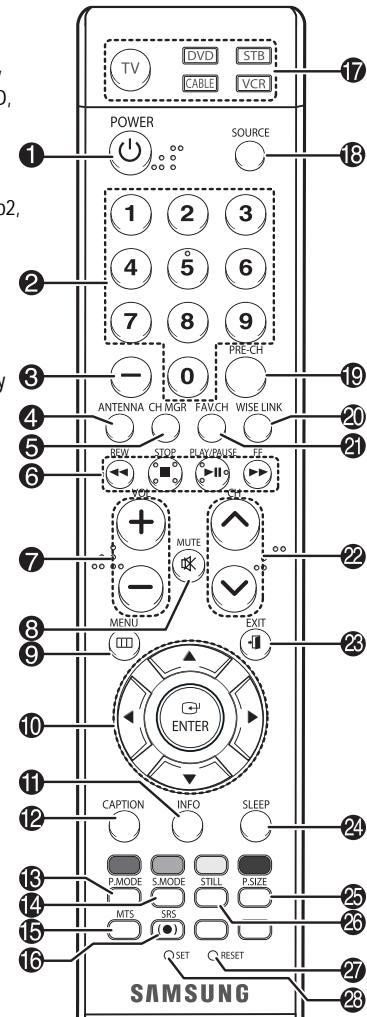



NOTES

- The Color buttons are used during the channel list function. (Refer to pages 48-53)
- This is a special remote control for the visually impaired, and has Braille points on the POWER, VOL +, VOL -, CH ▲/▼, STOP, and PLAY/PAUSE buttons.
- The performance of the remote control may be affected by bright light.

12. Disassembly & Reassembly

12-1 Overhaul Disassembly & Reassembly

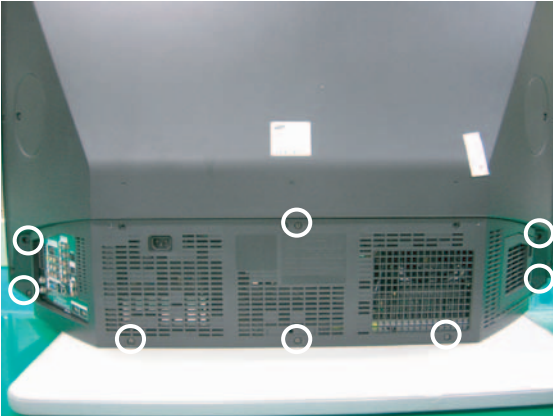
12-1-1 Separation of the back cover and the chassis

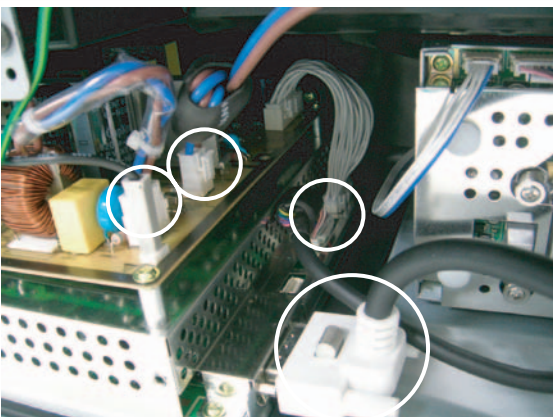
Part Name	Description	Description Photo
Back Cover	<p>① Remove 8 screws to remove the back bottom cover. : BH,+,B,M4,L12,ZPC(BLK),SWRCH18</p> <p>② The back cover has to be pulled to the right before being pulled backwards, due to the AIR FLOW guide gets caught on the CHASSIS FRAME.</p>	
Terminal Board	<p>① Remove the Holder Terminal.</p>	
Holder Chassis	<p>① Separate the 8 cables.</p> <p>⚠ Notice: The DVI screw is made of soft plastic and may easily break when applying excessive force through a screw driver. Ensure that extreme caution is taken when loosening the screw.</p>	

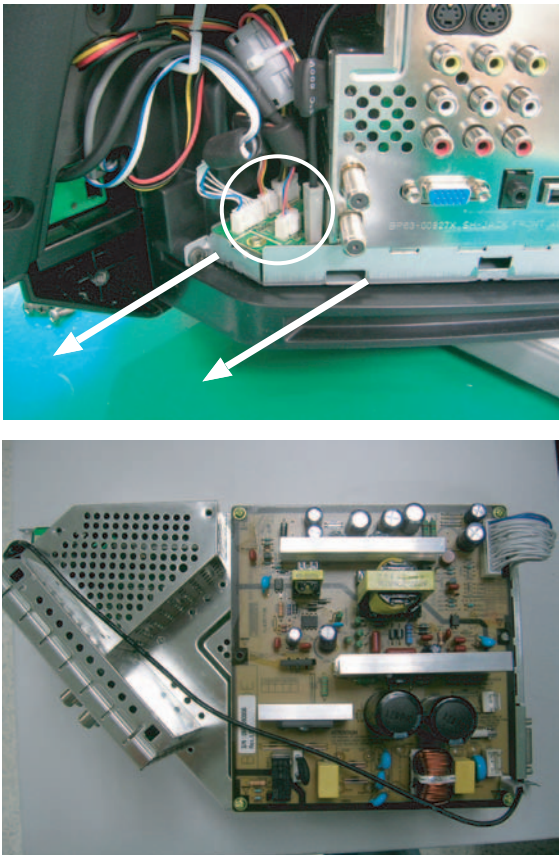
Part Name	Description	Description Photo
Holder Chassis	① The chassis should be pulled out towards the left side.	

12-1-2 Separation of the Main Board and Power Board

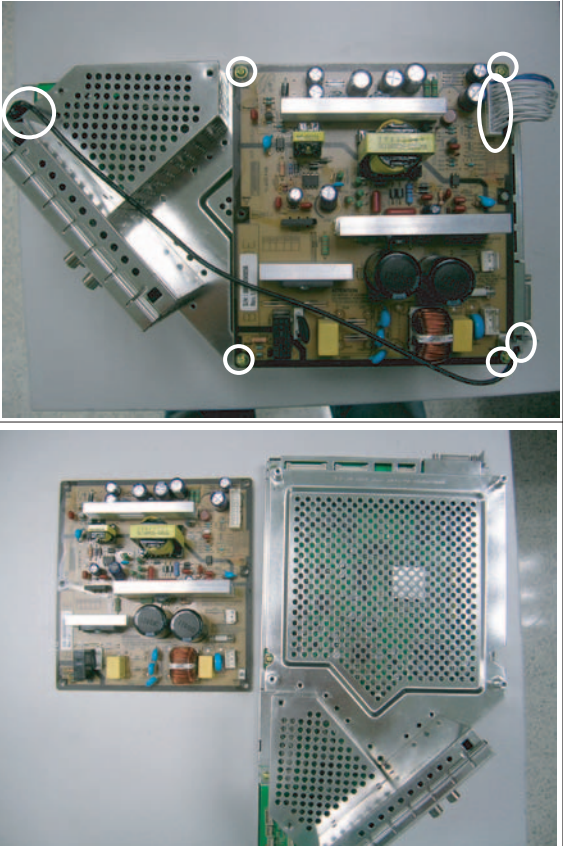
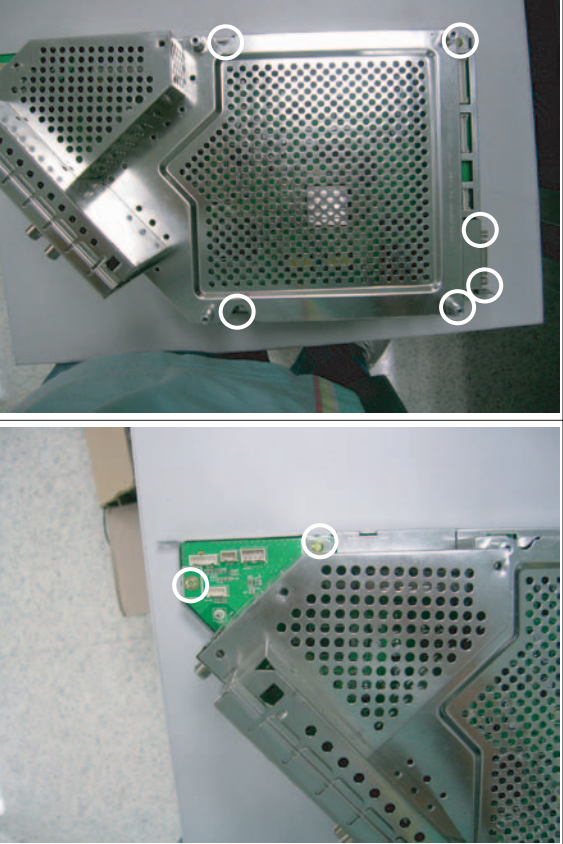
Part Name	Description	Description Photo
Main,Power Board	<p>① Remove the 2 cables and 4 screws. and Separate SMPS. :PWH,+ ,B,M3,L10,ZPC(YEL),SWRCH18A</p>	
	<p>① Remove the 6 screws and 2 standoffs. : PWH,+ ,B,M3,L10,ZPC(YEL),SWRCH18A</p>	

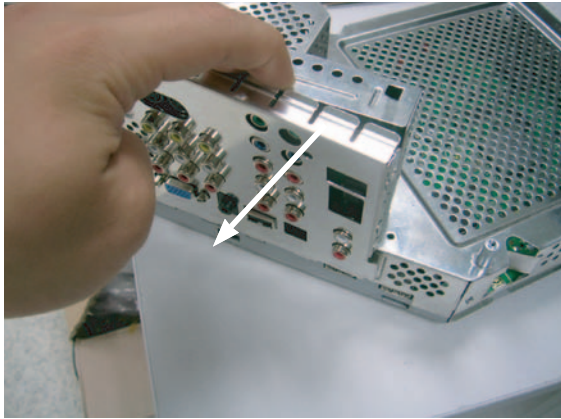
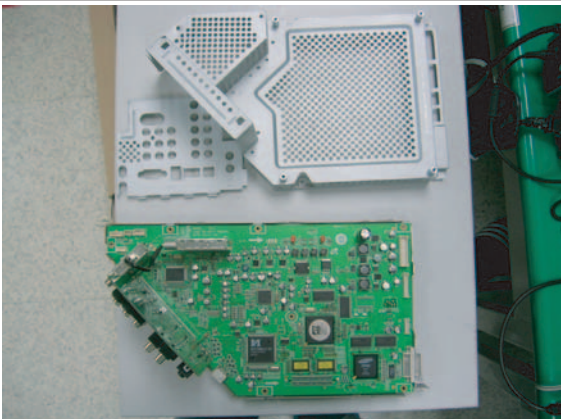
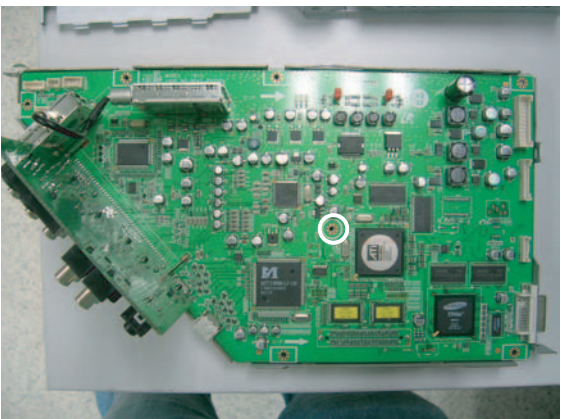
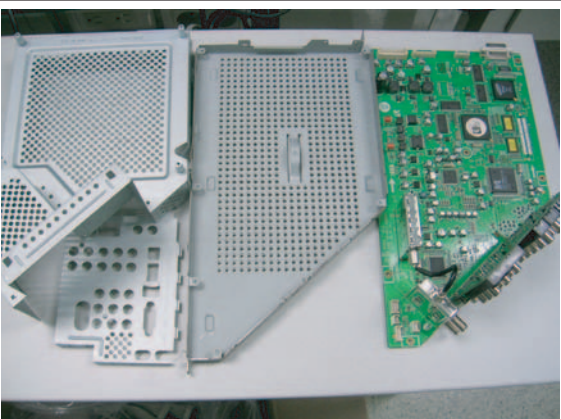
Part Name	Description	Description Photo
Main,Power Board	① Remove the shield case.	 
	① Remove the 1 screw. and Separate the Main Board. :PWH,+B,M3,L10,ZPC(YEL),SWRCH18A	 

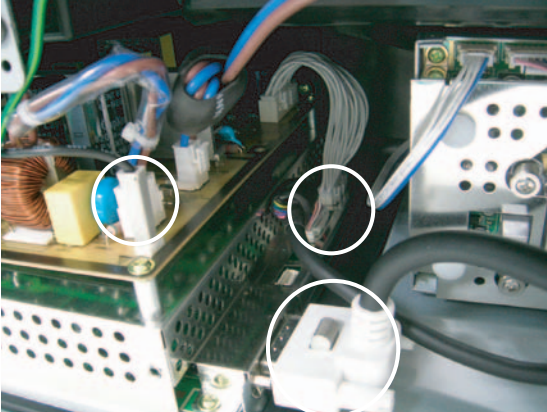
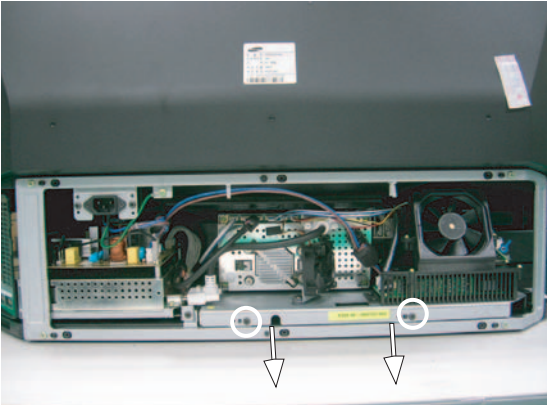

12-1-3 Separation of the Optical Engine

Part Name	Description	Description Photo
Optical Engine	<p>① Remove 2 screws and separate 3 cables. : BH,+,B,M4,L12,ZPC(BLK),SWRCH18</p>	
	<p>① Remove the engine by pulling it out of the cabinet.</p> <p>⚠ : Be careful when removing the Light Engine as it may get caught up by the upper cable of the case.</p>	

12-1-4 Lamp Replacement

 Notice

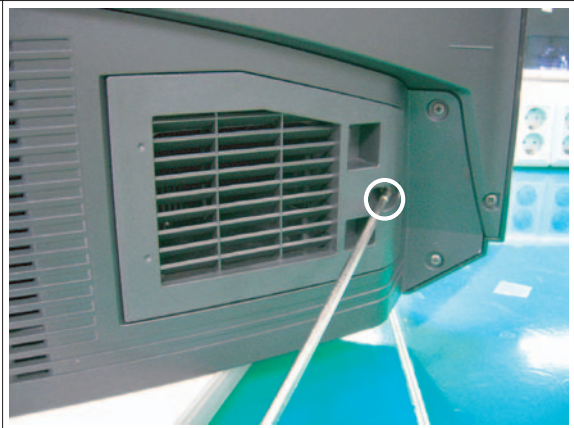
1. Replace with the correct code numbered lamp to avoid damage to the TV.
2. Turn the power off and wait for 30 minutes before replacing the lamp as it will be hot.
3. Do not touch the glass part of the lamp with your bare hands nor insert any foreign object inside the cover as it may cause poor screen quality, electric shock or fire.
4. Do not place the old lamp near flammable objects or within the reach of children.
5. Be sure to connect this TV directly to an AC wall outlet. If the TV's AC plug is connected to a cable box or other source, it will not allow for proper cool down time.

Part Name	Description	Description Photo
Lamp	① Unplug TV, then use a screwdriver to remove the screws. :BH,+ ,B,M4,L12,ZPC(BLK),SWRCH18	
	① Remove the Lamp cover.	

Part Name	Description	Description Photo
Lamp	① Push the clip and pull down the Lamp holder.	

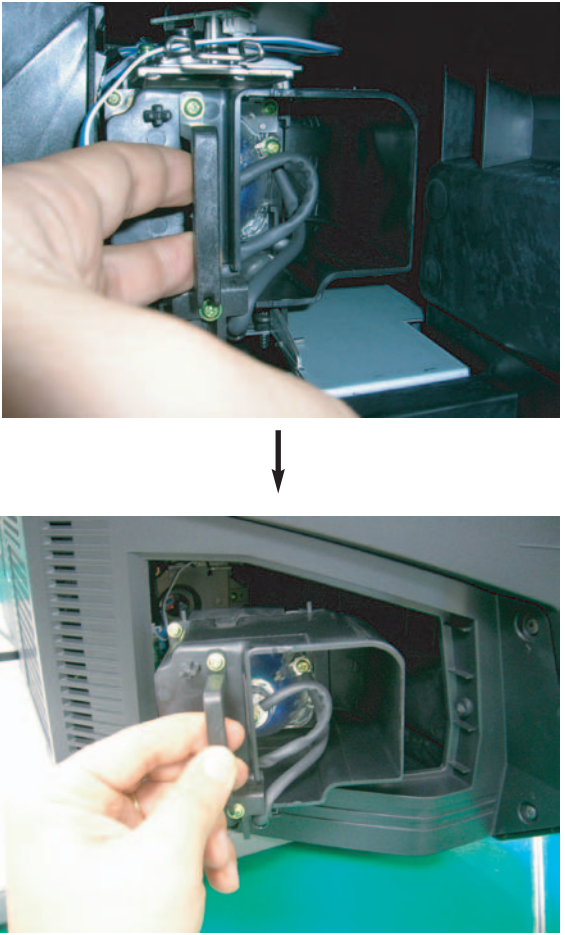
Part Name	Description	Description Photo
Lamp	① Separate the Lamp from the engine by holding the handle and pulling it out.	 <p>The 'Description Photo' column contains two sequential photographs. The top photograph shows a person's hand holding a metal handle that is part of a lamp assembly, pulling it away from the engine. The bottom photograph shows the handle being pulled further out, with a downward-pointing arrow between the two images to indicate the sequence of the disassembly process.</p>

12-1-5 Ballast Replacement

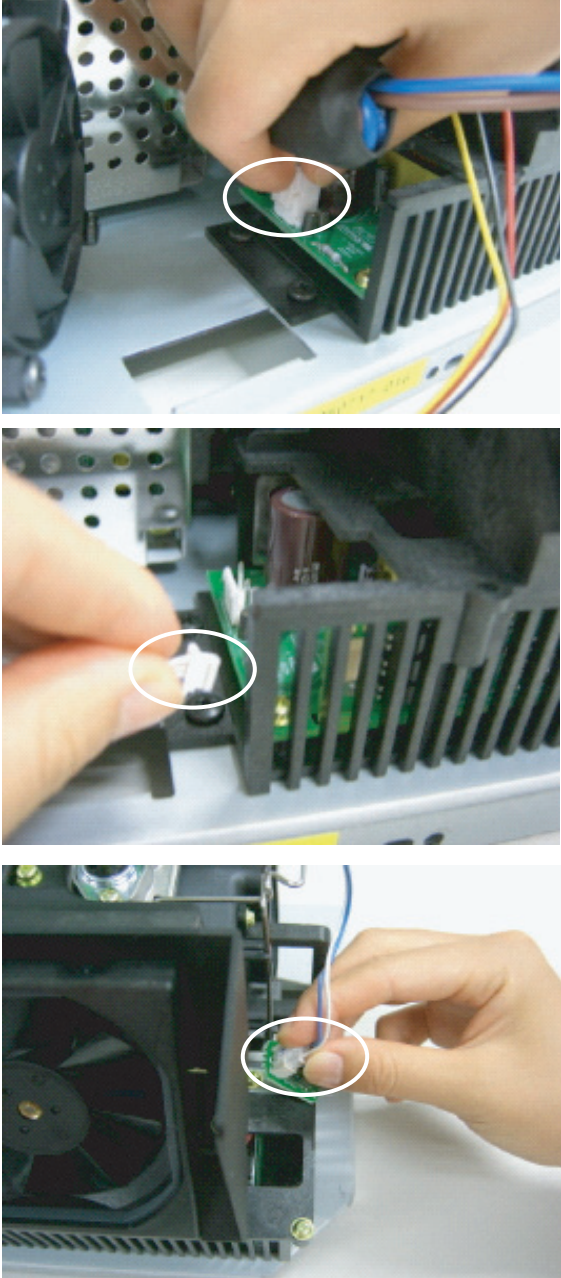
Part Name	Description	Description Photo
Ballast Board	① Remove the 3 cables.	

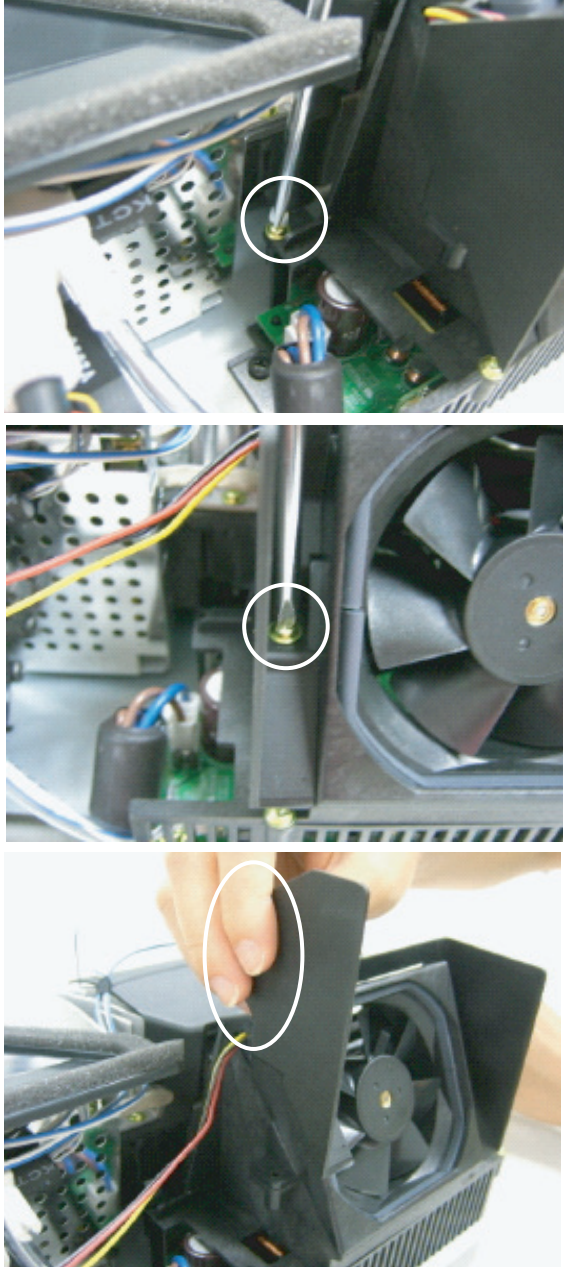
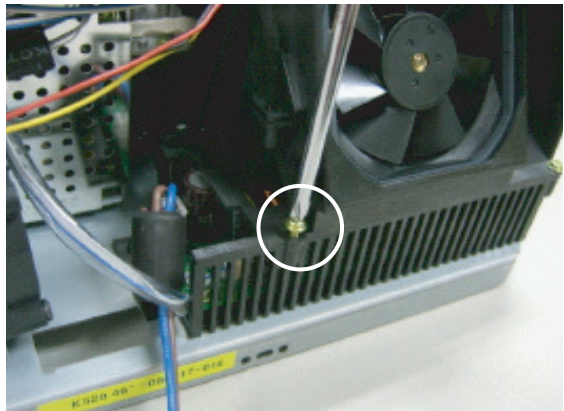
Part Name	Description	Description Photo
Ballast Board	① Remove the 2 screws and Fan cover.	
	① Remove the 2 screws and Fan.	

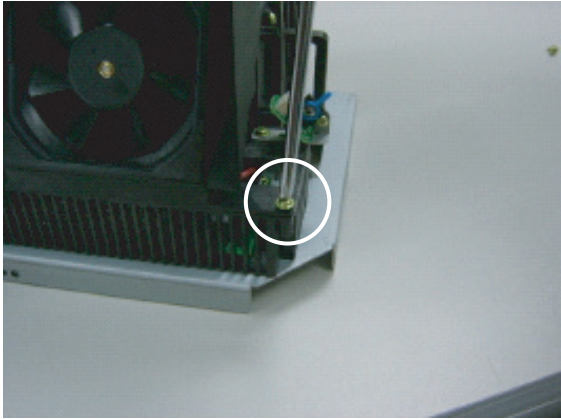
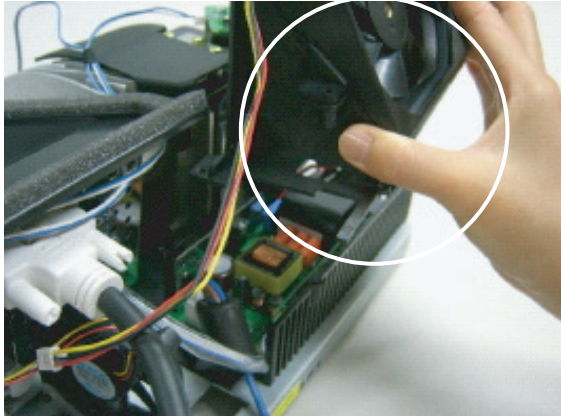
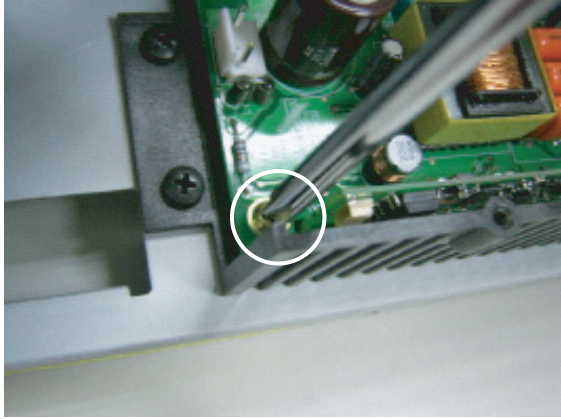
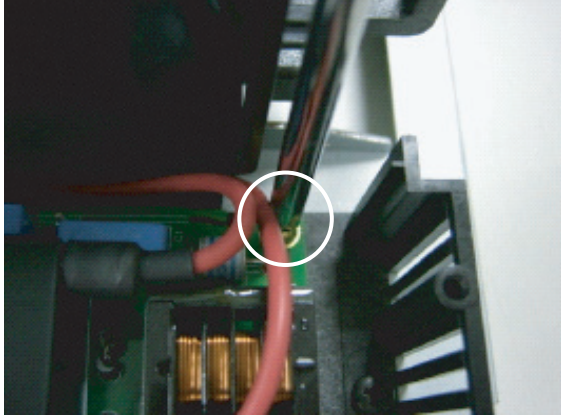
Part Name	Description	Description Photo
Ballast Board		 
	① Remove the 3 screws and separate Ballast.	 

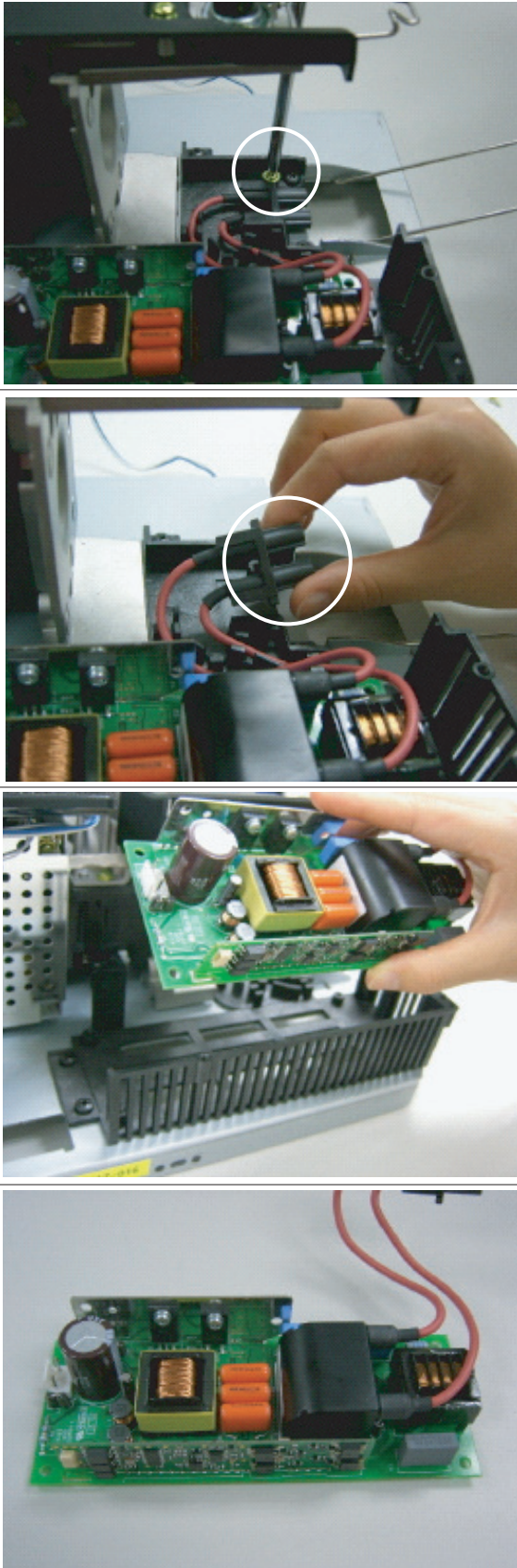
Part Name	Description	Description Photo
Ballast Board		 <p>The 'Description Photo' column contains four sequential images illustrating the removal of the ballast board. The first image shows the board installed in a chassis with a screw circled in white. The second image shows a hand unscrewing the board. The third image shows the board being lifted out of the chassis. The fourth image shows the ballast board removed and lying flat, revealing its components: a large electrolytic capacitor, a transformer, three orange capacitors, and a black heat sink.</p>

12-1-6 Color Wheel Ass'y Replacement

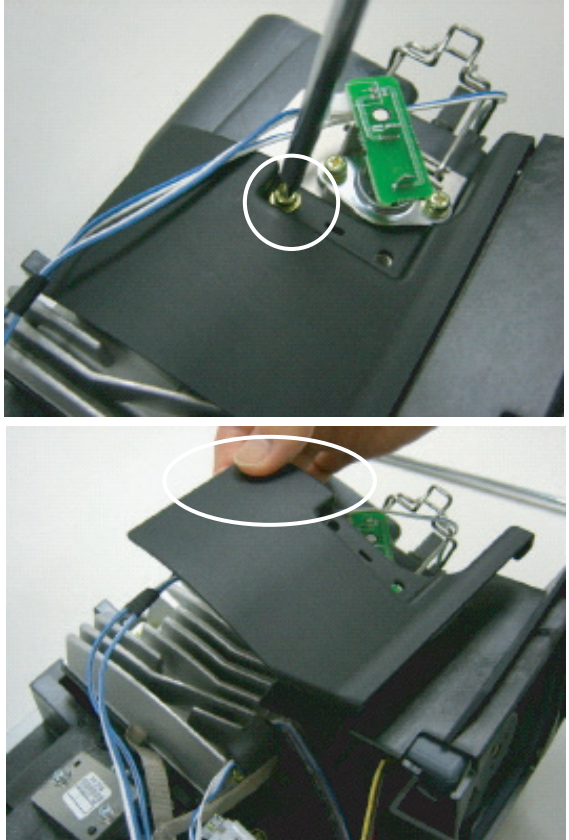
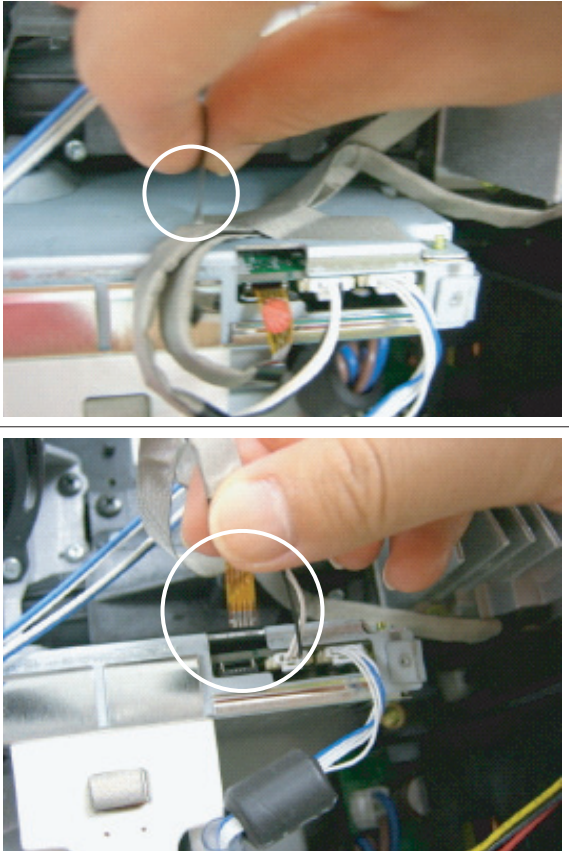

Part Name	Description	Description Photo
Color Wheel	<p>① Remove the 2 screws and separate lens cover. (L620 doesn't have the cover color wheel.) : WSP,PH,+,M3,L8,ZPC(YEL),SW</p>	
	<p>① Remove the 2 screws and separate color wheel cover.</p>	

Part Name	Description	Description Photo
Color Wheel		
	<p>① Remove the gasket tape and separate 2 cables.</p>	

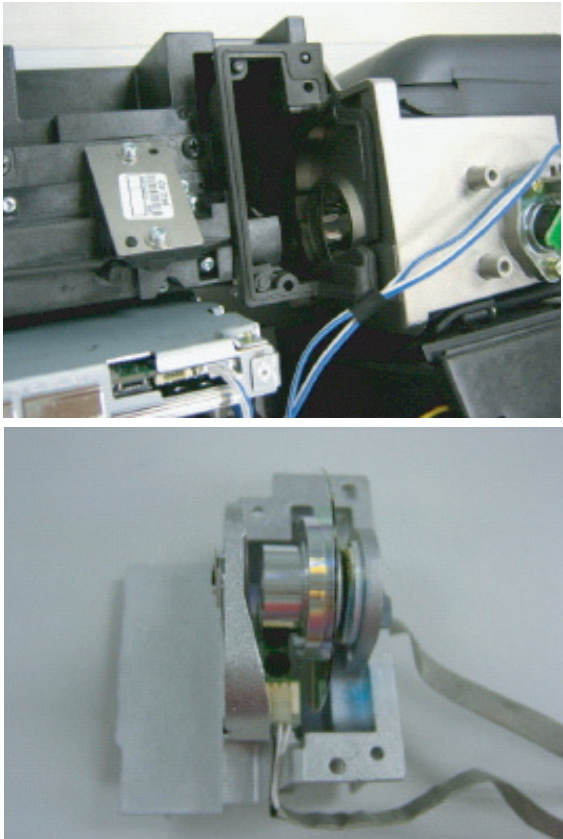
Part Name	Description	Description Photo
Color Wheel		
	<p>① Remove 2 screws and separate color wheel assy.</p>	

Part Name	Description	Description Photo
Color Wheel		

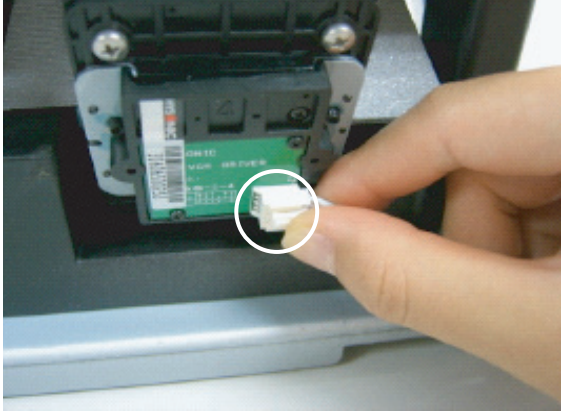
12-1-7 Actuator(Smooth Picture) Replacement

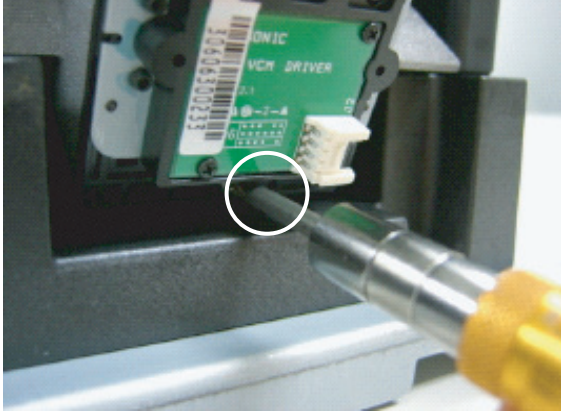
Part Name	Description	Description Photo
Actuator	① Separate the cable.	
	① Remove the 3 screws.	  

Part Name	Description	Description Photo
Actuator	① Pull out the actuator.	 A close-up photograph showing a person's hand pulling a black, rectangular actuator component out of a grey plastic housing. The actuator has a small tab on its side. The background shows the internal structure of the device.

12-1-8 Separation of the DMD Board

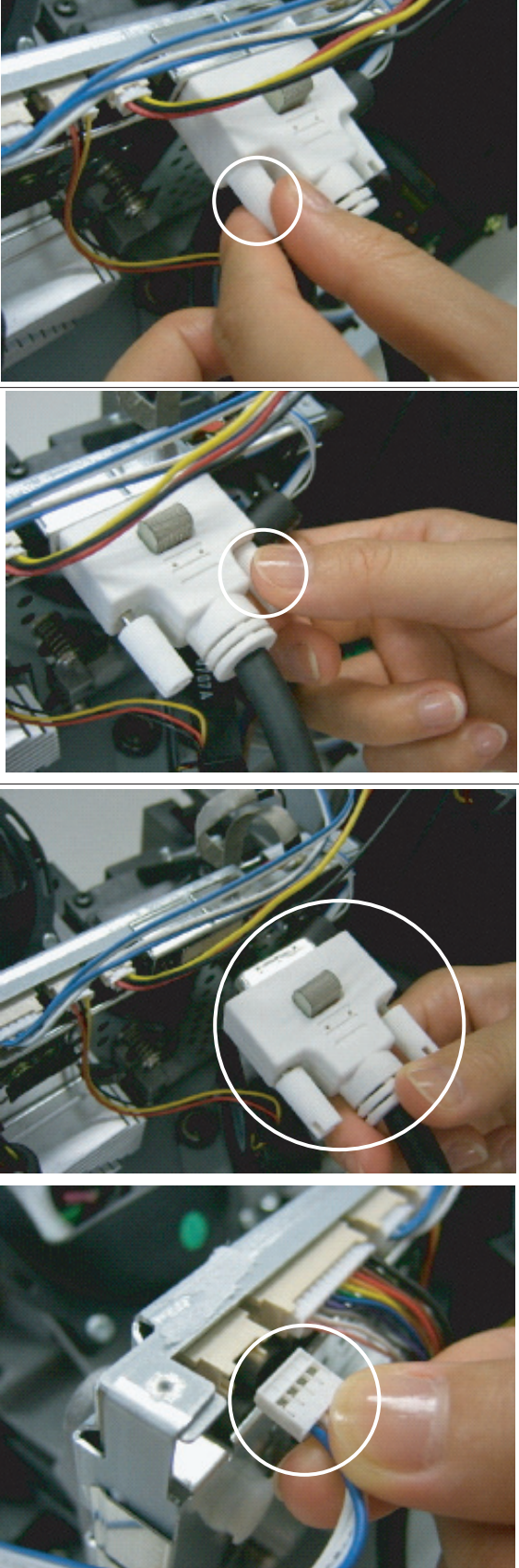
Part Name	Description	Description Photo
DMD Board	① Remove the DVI cable and actuator cable.	 <p>The 'Description Photo' column contains four sequential photographs illustrating the removal of the DVI cable and actuator cable from the DMD board. Each photo has a white circle highlighting the specific cable being handled.</p> <ul style="list-style-type: none">The first photo shows a hand pulling a white DVI cable out of its connector on the board.The second photo shows a hand pulling a black actuator cable out of its connector.The third photo shows a hand pulling a white cable out of a connector.The fourth photo shows a hand pulling a white cable out of a connector.

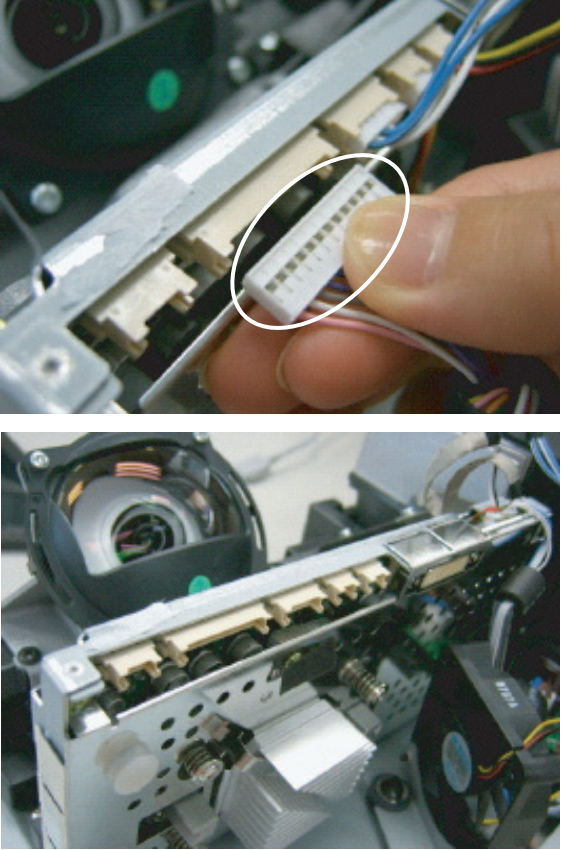
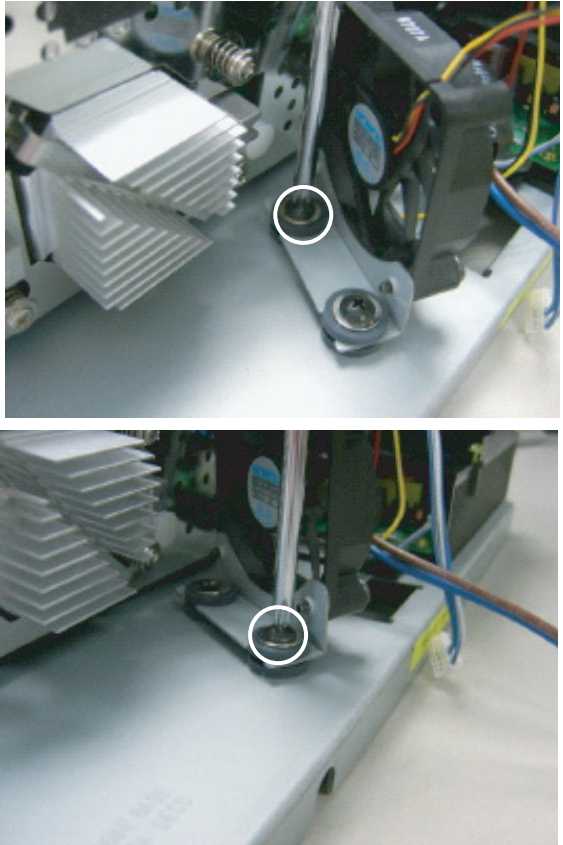
Part Name	Description	Description Photo
<p>DMD Board</p>	<p>① Remove the 4 cables.</p>	
	<p>① Remove 2 screws and separate fan assy.</p>	

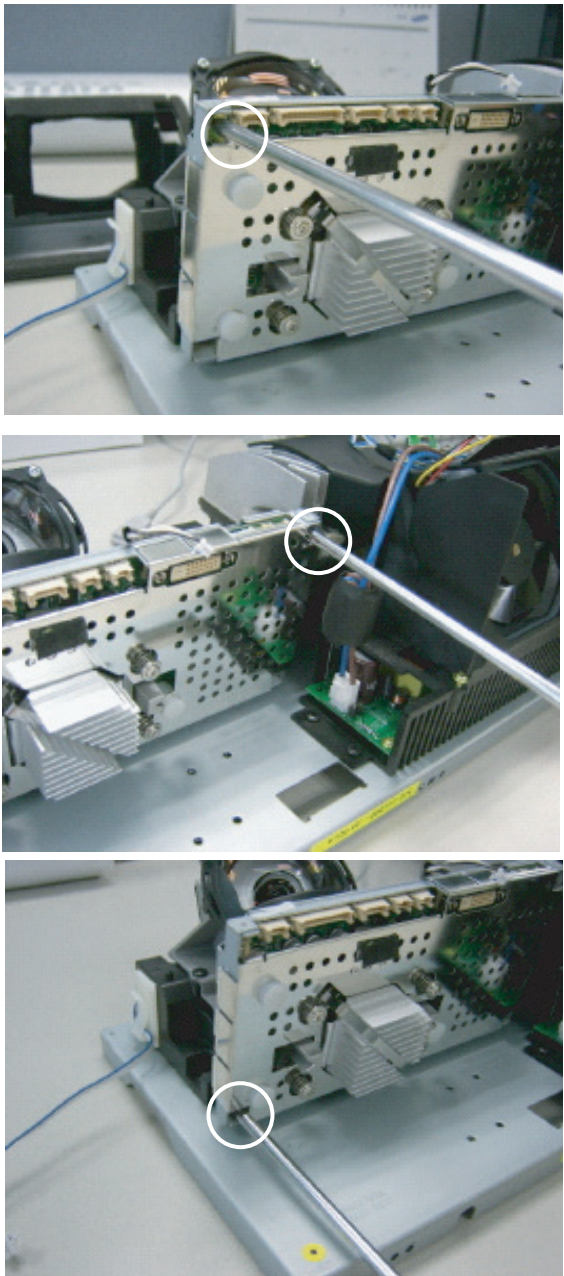
Part Name	Description	Description Photo
<p>DMD Board</p>		
	<p>① Remove the 4 screws.</p>	

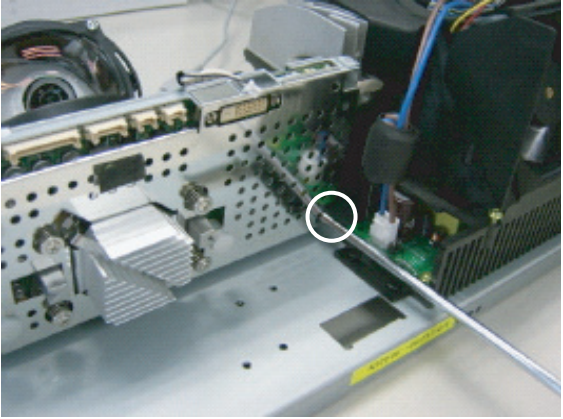
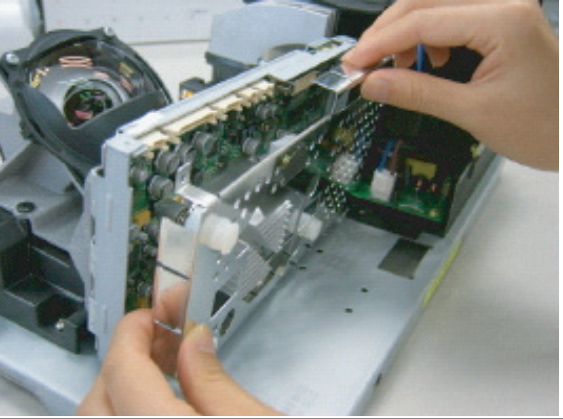
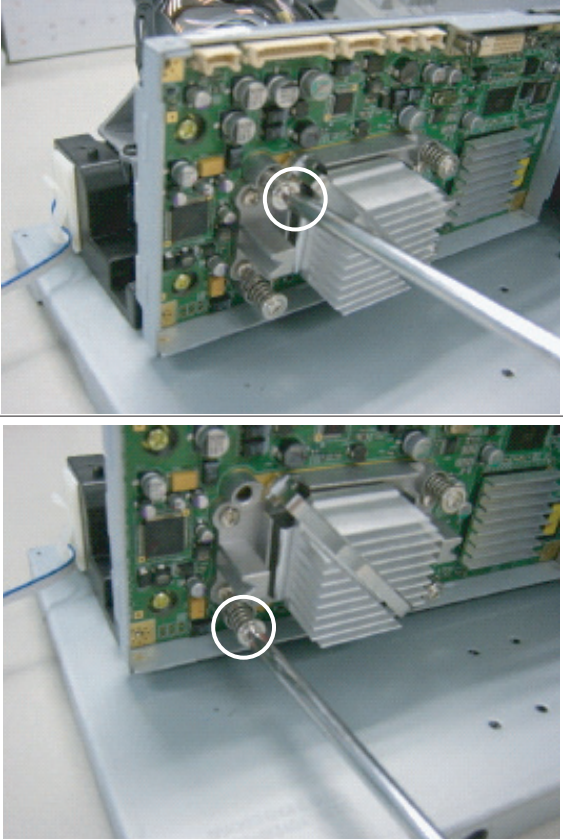

Part Name	Description	Description Photo
DMD Board		
	<p>① Pull out the shield case.</p>	
	<p>① Remove the 8 screws.</p>	

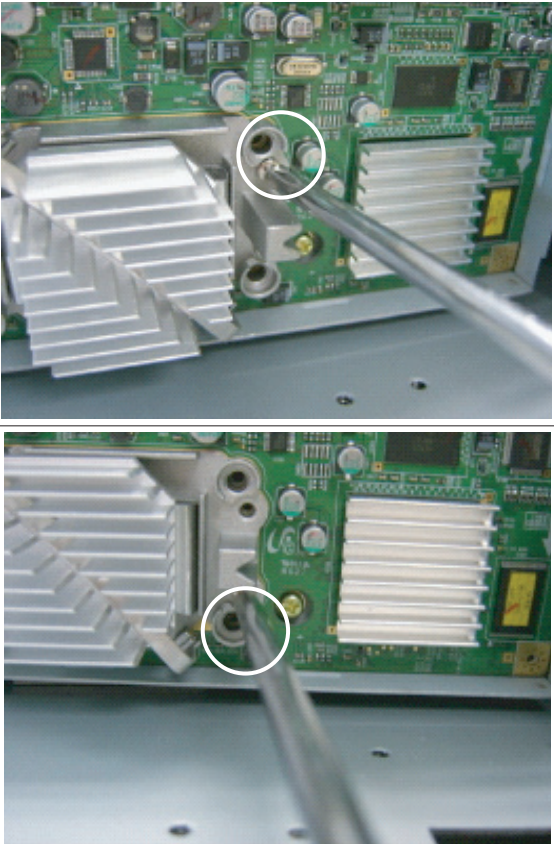
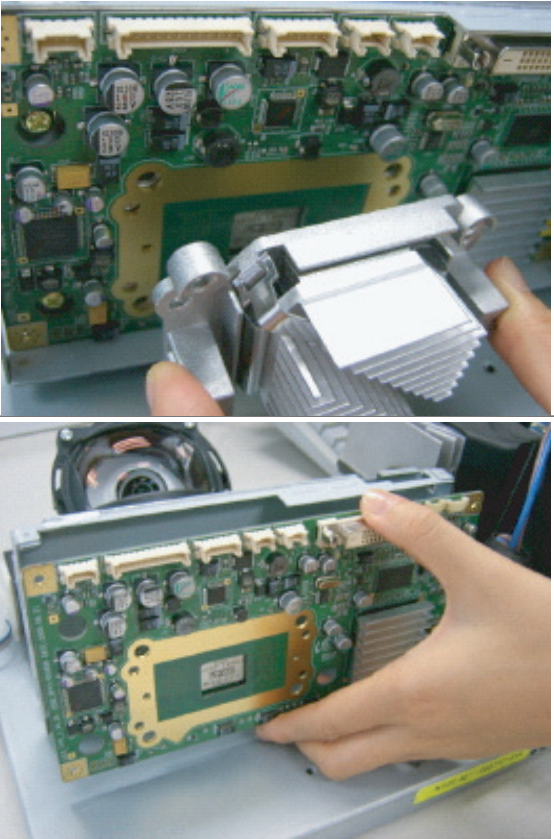
Part Name	Description	Description Photo
<p>DMD Board</p>		 <p>The 'Description Photo' column contains four sequential photographs illustrating the removal of a screw from the DMD board. Each photograph shows a close-up of the green printed circuit board (PCB) with various electronic components. A silver screwdriver is used to turn a screw, which is highlighted by a white circle in each image. The sequence shows the screw being loosened and then fully removed from the board.</p>

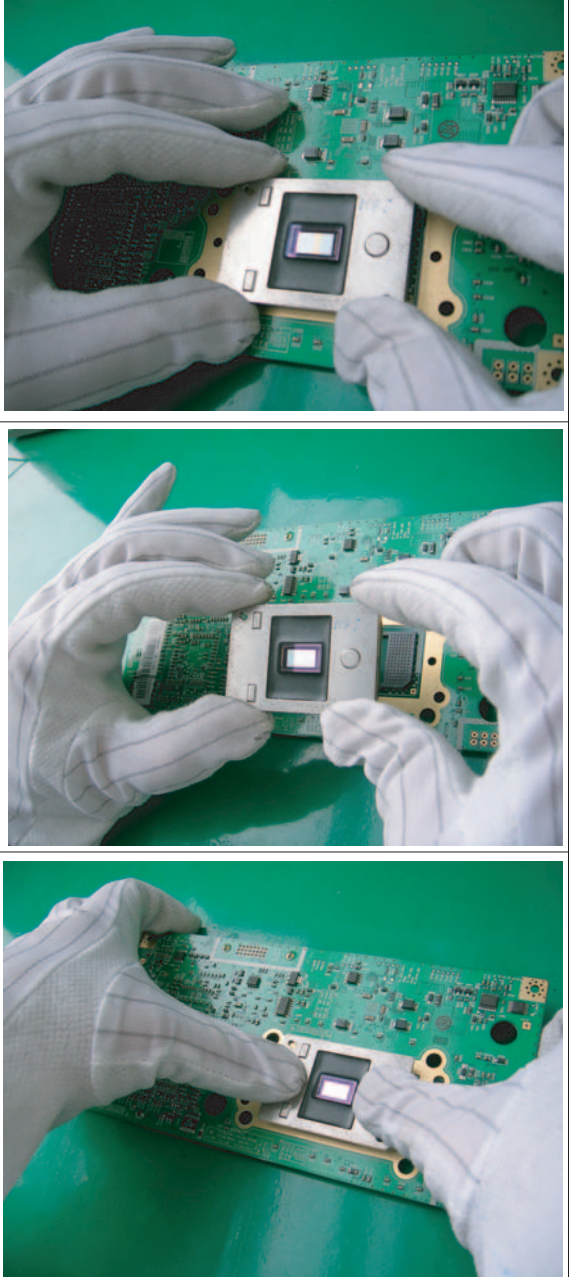
Part Name	Description	Description Photo
<p>DMD Board</p>		
	<p>① Remove the Heat sink and separate DMD Board.</p>	

Part Name	Description	Description Photo
DMD Board	<p>① Pull out the DMD and replace it.</p> <p>⚠: Be careful not to bent a pin</p>	

12-1-9 Separation of the SCREEN

Part Name	Description	Description Photo
Front, Rear	① Set.	
	① Separate 10 screws for fixing COVER-REAR and COVER-FRONT. ② Separate 10 screws for fixing COVER-REAR, BOT and COVER-FRONT. :BH,+ ,B,M4,L12,ZPC(BLK),SWRCH18 ③ Separate BOT and COVER-REAR.	 

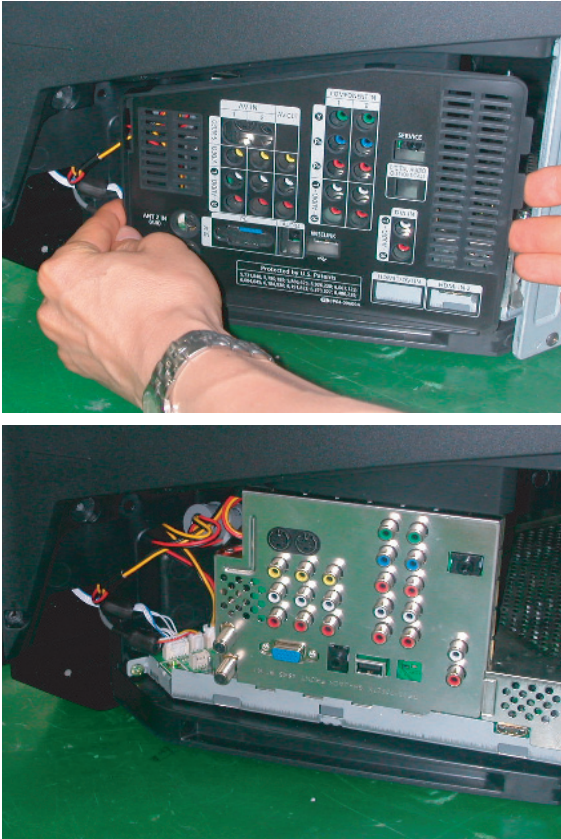
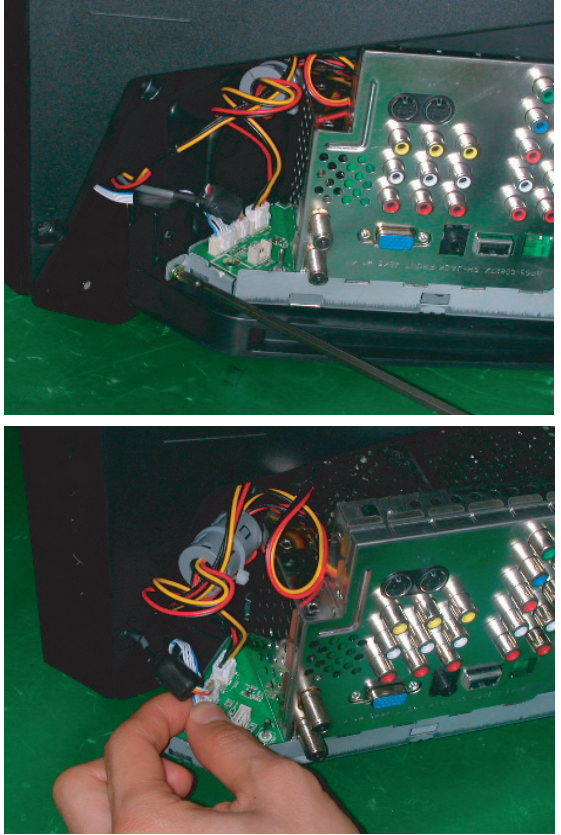

Part Name	Description	Description Photo
<p>HOLDER-TERMINAL</p>	<p>① After separating COVER-REAR and BOT, separate HOLDER-TERMINAL.</p>	
<p>Connector</p>	<p>① Separate 2 BRKT-CHASSIS fixed screws. ② Pull out CHASSIS ASSY on the left side slightly, and separate CONNECTOR</p>	

Part Name	Description	Description Photo
Front	① Separate COVER-FRONT from SET.	
BRKT-SCREEN	<p>① Separate 2 KNOB-CONTROL fixed screws on the side. :BH,+,B,M4,L10,YEL,SWRCH18A</p> <p>② Separate KNOB-CONTROL.</p>	 

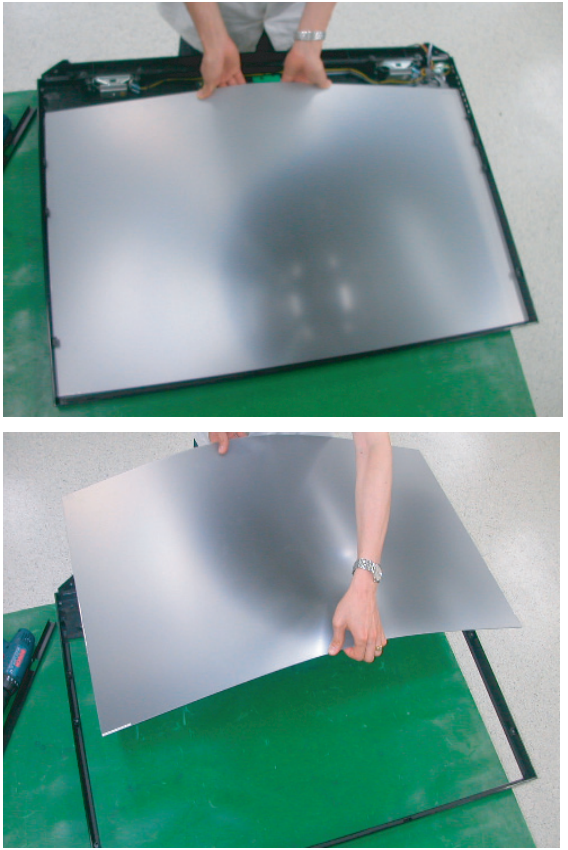
Part Name	Description	Description Photo
<p>BRKT-SCREEN</p>	<p>① Separate 3 screws fixing BRKT-SCREEN. :BH,+,B,M4,L10,YEL,SWRCH18A</p>	
	<p>① Delete BRKT-SCREEN as pushing it to the left side. (TOP, BOT)</p> <p>② Delete BRKT-SCREEN as pushing it to the upside.(LEFT)</p> <p>③ Delete BRKT-SCREEN as pushing it to the lower part.(RIGHT) (The direction in the parenthesis is the standard of the rear)</p>	

Part Name	Description	Description Photo
Screen	<p>① Pick the screen slightly and put your hand in the center of screen and pull it toward the front and separate screen.</p> <p>② Separate the screen in the COVER-FRONT.</p>	 <p>The 'Description Photo' column contains two sequential photographs. The top photograph shows a person's hands lifting a large, rectangular, silver-colored screen from the back of a black device. The bottom photograph shows the same person's hands pulling the screen away from the front cover of the device, which is lying flat on a green surface.</p>

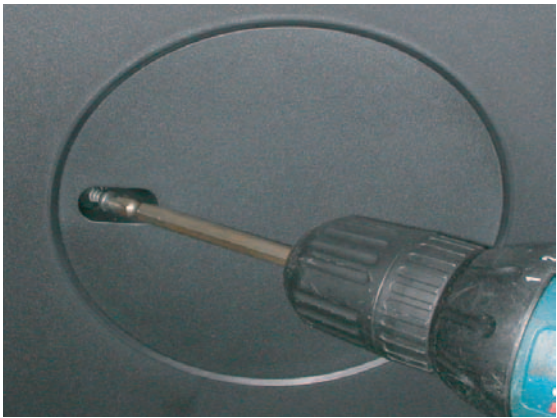
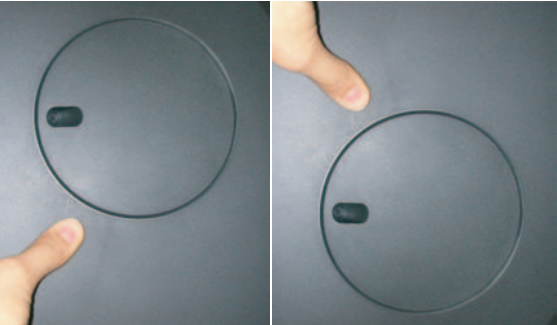
12-1-10 Separation of the COVER-DUST

Part Name	Description	Description Photo
COVER-DUST	① COVER-DUST	
	① Separate 1 screw for fixing COVER-REAR and COVER-DUST :BH,+B,M4,L12,ZPC(BLK),SWRCH18	
	② Push the indicating sign of the picture and separate SNAP of C/DUST from C/REAR (Pushing part : the upper or lower part of jointing Screw)	
	③ Separate C/DUST with using the gap which occurs when SNAP of C/DUST is separated.	

Part Name	Description	Description Photo
		

13. Circuit Description

13-1 Overall Block Description

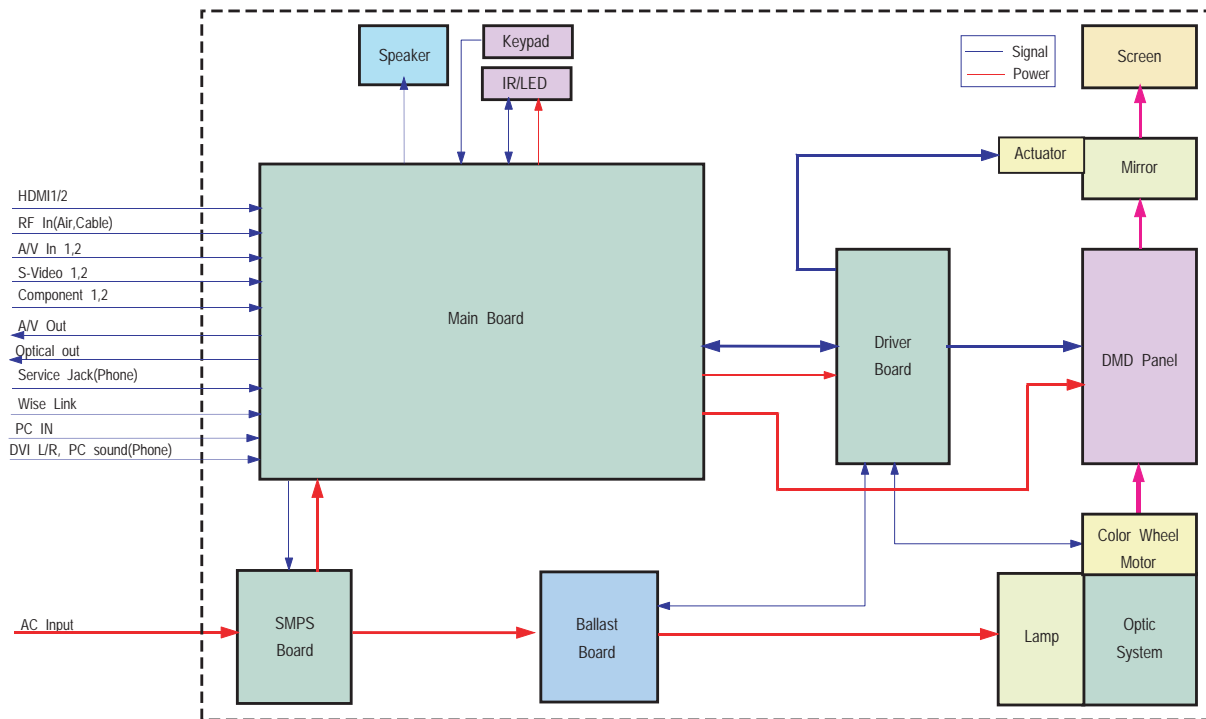

The ass'y that consists of the DMD board, Detect (Actuator) board, lamp, ballast and optical devices is called the Engine.

The Main board part receive the AV signals to output voice signals and process the remote control signals.

The engine part displays the video data on the screen, which is generated in the Main board.

The AV signals are input through the Main board. X240&MST3389 process the MUX and decoding and X240H processes the CPU functions, MPEG and I2S.

Finally, the improved DNle image is sent to the DMD engine board.

The final data by DNle is processed in DDP3021 of the DMD board to display the image on the DMD panel. This image is created by the light of the lamp through the color wheel which is enlarged and projected onto the screen.

This is the DLP of the K2 type that the actuator operates additionally during this process.

The power terminal generates the DC power needed for the product and sends it to the Main board. The Main board supplies the power to the DMD board.

In the meantime, the power source board supplies DC220v - 400v directly to the ballast in order to light the lamp.

The ballast is like a stabilizer for lighting the lamp.

The ultimate purpose of the TV set is to project an image onto the screen and output the voice signals synchronized with the image. And based on the DMD panel used, a 1-panel TV requires a color wheel while a 3-panel TV does not. The HD5 panel needs an actuator while the HD2 does not. However, the drive mechanism and the overall block structure of the two panels are the same.

13-2 Partial Block Description

13-2-1 SMPS Block Description

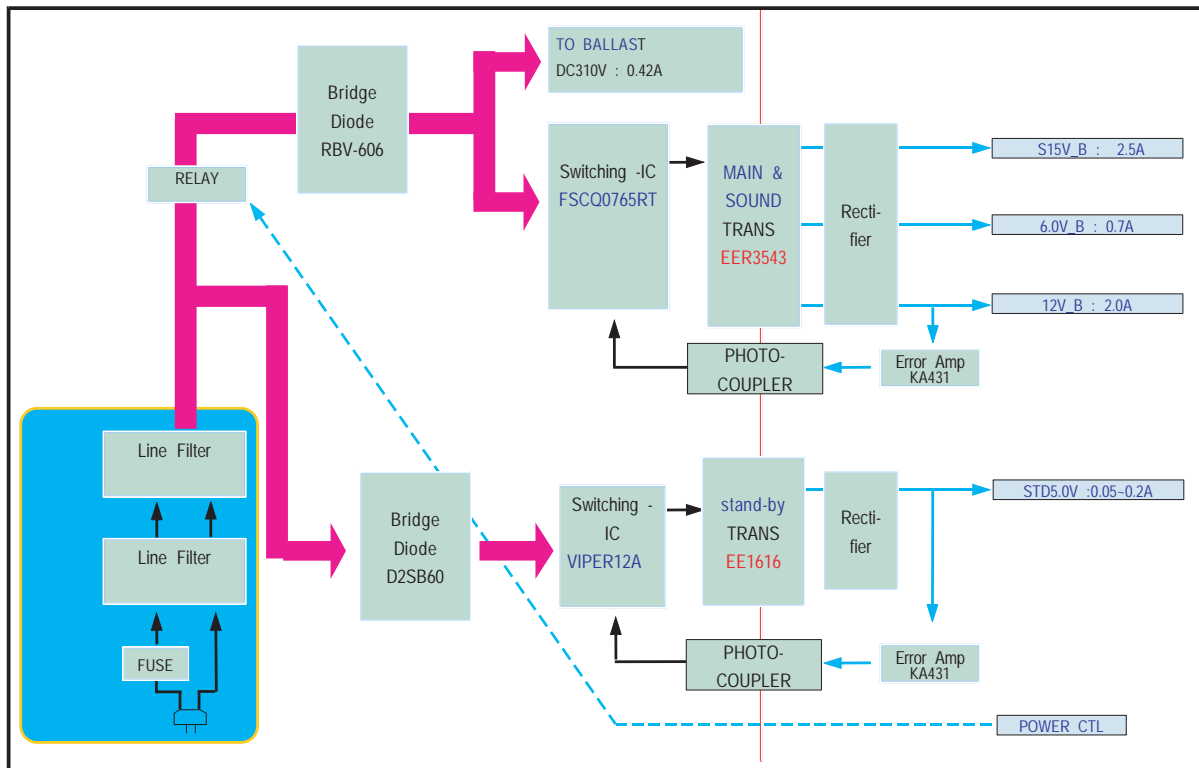

1. What is SMPS?

This is an acronym for Switching Mode Power Supply and this is responsible for receiving AC input voltage (Line frequency: 50HZ~60HZ) and supplying insulated DC output.

2. SMPS Components

- 1) Standby Power: A combination of ICS801 (SWITCHING IC) and TS801S (TRANS) that supplies STAND-BY 5V for operating the Micom.
- 2) Multi Power: The voltage supplied when the power is turned on.
It is a combination of IC801S and T801S that supplies various voltages including 12V_B, 6.0V_B, S15V_B.

3. SMPS Operation

- 1) SMPS System: Uses Fly-Back technology for both standby and multi power.
- 2) Operation: Fly-Back is one of the most popular power-supply systems and uses less power than 200W as well as being the cheapest of all multi output SMPS systems.

Let's have a look at how it operates...

- a. Converts AC input into DC (HOT) (rectifies to DS801 before smoothing to CS801)
- b. The converted DC voltage is high, especially compared to ground, so touching it will cause electric shock.
Use T801S (Trans) to insulate the secondary voltage and take advantage of the PWM operations of T801S and IC801S to induce it.
- c. The secondary induced voltage is 66KHz square wave power, which goes through the smoothing cap (CS822) to be generated in the standby 5V.
- d. Multi power also operates the same way.

4. Input&Output voltage

- 1) Input voltage
 - * America(AC120V) - OPTION
 - * Korea(AC220V) - OPTION
 - * The others(AC100V~AC240V) - OPTION
- 2) Output voltage
 - * 12V / 2.5A - 12V , 3.3V , 1.8V : For signal processing
 - * 6.0V / 1A - For driving the tuner
 - * 16V - For driving sound amp

13-2-2 Digital Block Description

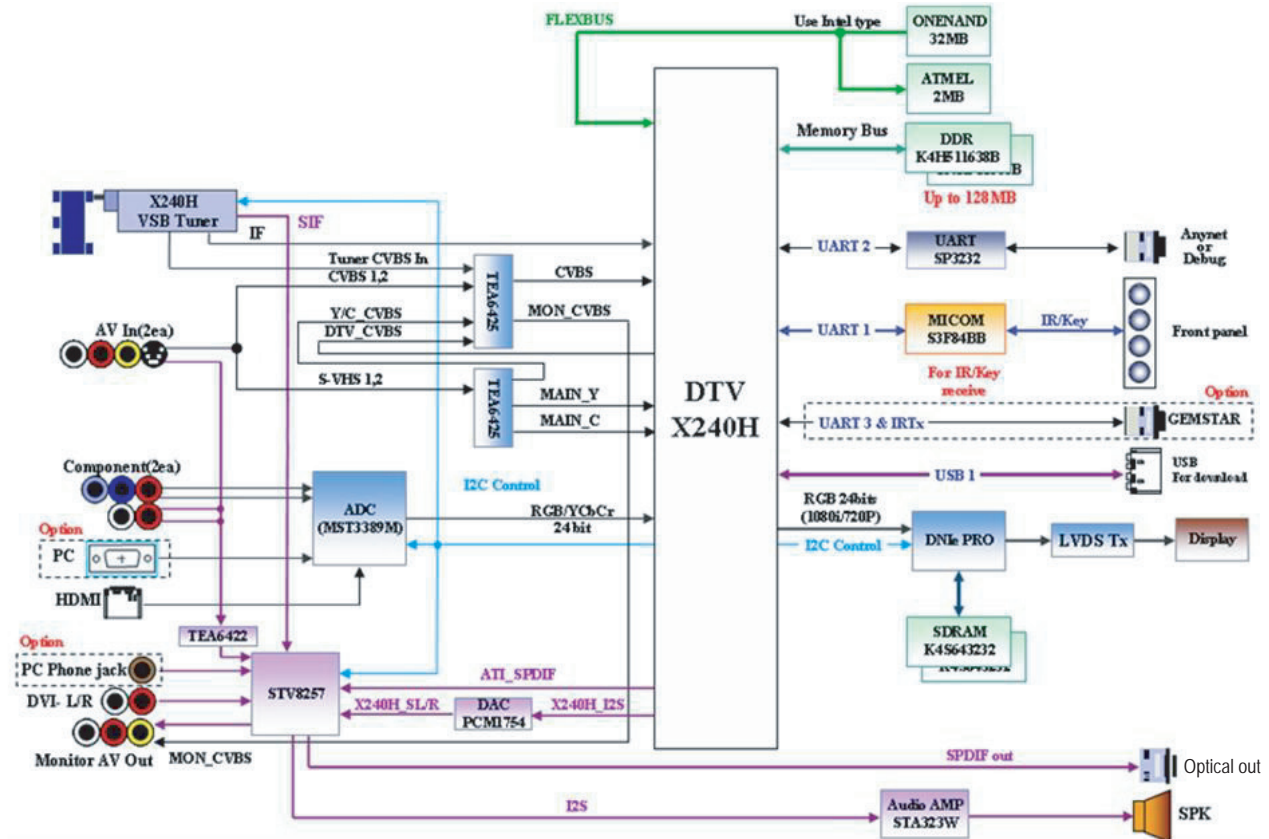

- TEA6425 : TUNER_CVBS, AV, S-VHS INPUT MUXING AND SWITCH
- MST3389 : 2 ANALOG Y/Pb/Pr, 1RGB PC SIGNAL, 2 HDMI RECEIVER
- STV8258 : AUDIO PROCESSOR
- PCM1754 : AUDIO DAC, I2S INPUT SIGNAL AND TRANSFERS IT TO STV8258 IN L/R SIGNAL
- X240H : CPU, +MPEG DECODER, IF DEMODULATOR, AUDIO SIGNALS TRANSFERRED TO PCM1754 BY I2S
- DNIe : USES A NOISE-FILTERING AND PICTURE QUALITY IMPROCEMENT ALGORITHM TO IMPLEMENT NATURAL COLORS
- OTHERS : ANYNET IMPLEMENTATION, OPTICAL PORT, USB UPDATE PORT(NOT AVAILABLE FOR MP3)

The HLS5686W board contains HD tuners to implement analog as well as digital signals from air/cable broadcasting. It decodes Y PB PR and HDMI inputs using MST3389 Mstar chip, which is transferred to X240H (ATI), a combination of the main CPU and the MPEG decoder.

All video inputs are transferred to X240H for digital processing and all video output goes through DNIe to the DLP DMD board.

Audio signals are transferred to the STV8258 chip and are emitted through the speaker.

It also has a 5.1 channel optical port and a USB port for Wiselink and a S/W update

13-2-3 DMD Block Description

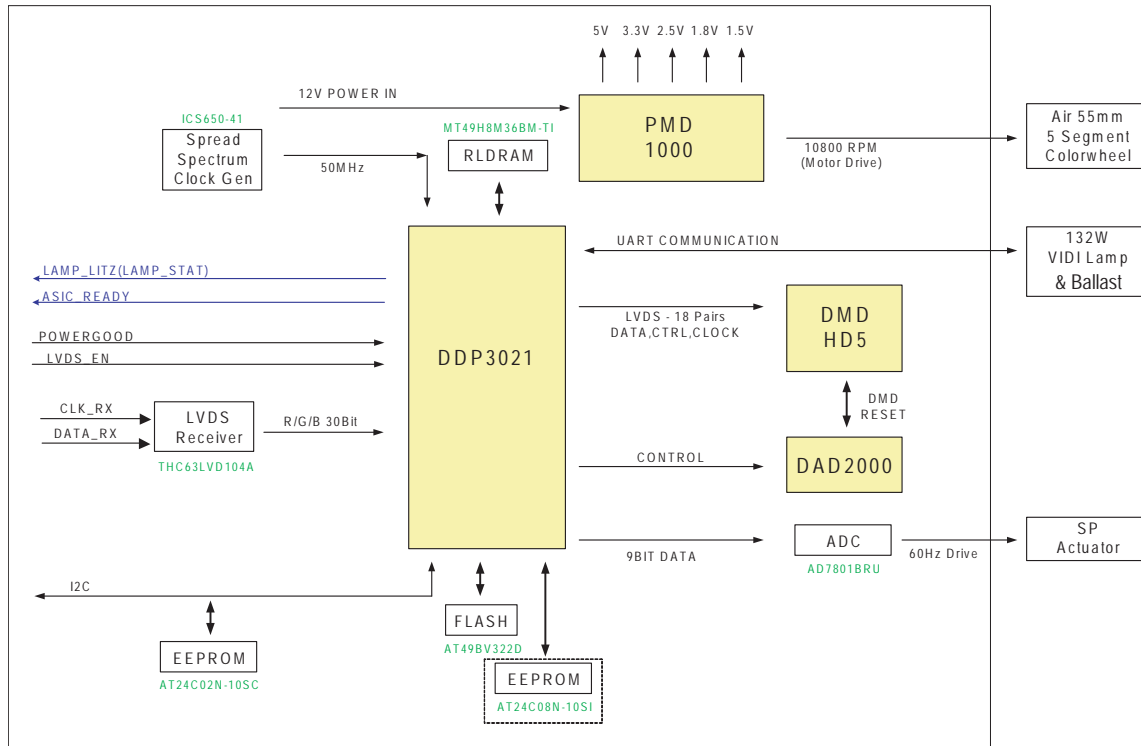

- TI Chip Set
- Controls the lamp (ON/OFF)
- Drives the color wheel motor
- Drives the panel

13-3 New Circuit Description

13-3-1 Output Voltage States of the DMD Board Parts

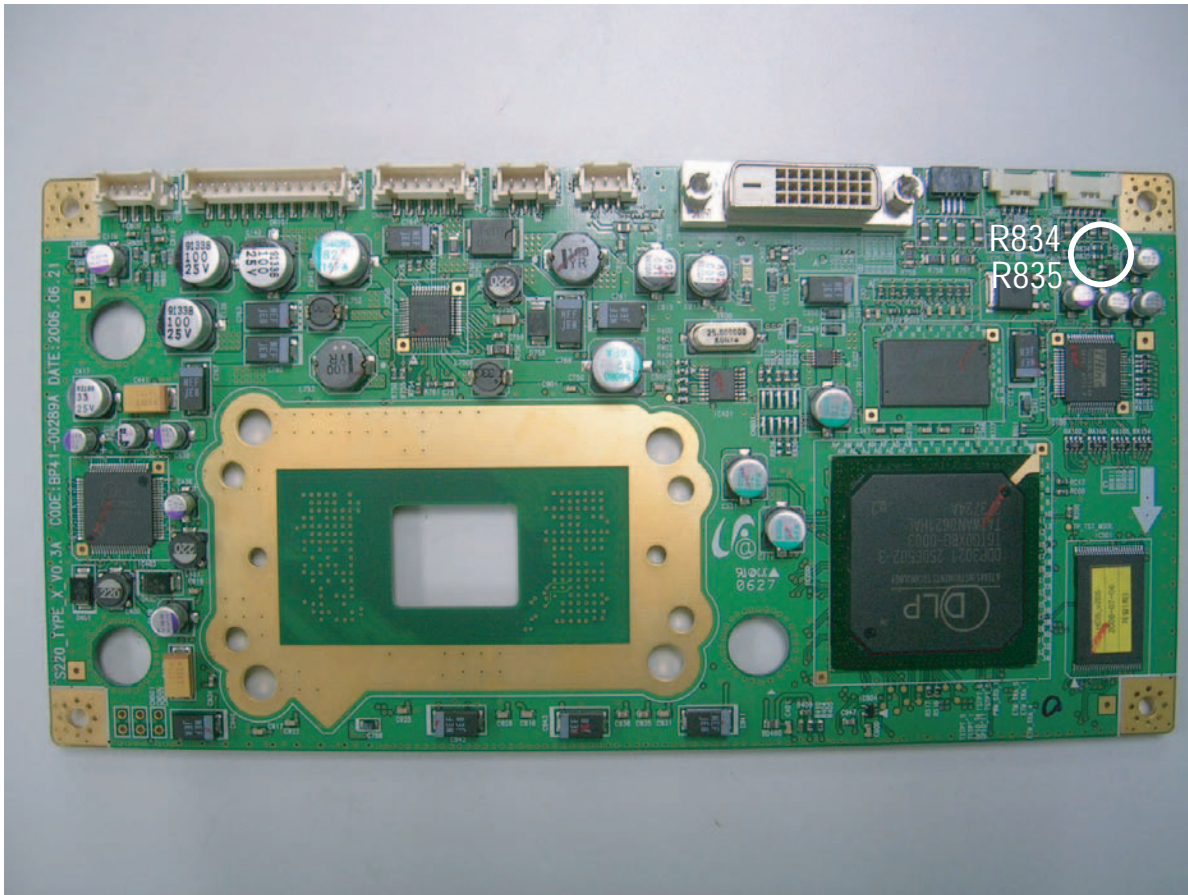

Loc.	Characteristics	
R835	LAMP EN	High from DDP3021(5V)
R834	LAMP LITZ	High (5V) before the lamp turns on. Low (0V) when the lamp turns on.

13-3-2 DMD Panel Pin Terminal Characteristics Diagram

※ Remove the heat sink attached to the DMD Board and tighten the screws in four places and then inspect the characteristics of each pin terminal.

	40	39	38	37	36	35	34	33	32	31	30	29	28	27	26	25	24	23	22	21	20	19	18	17	16	15	14	13	12	11	10	9	8	7	6	5	4	3	2	1					
A					V		V		DA	N6	DA	N4	V	DA	N2	DA	P0	V	G		G			V	V		G	G										V		N	A				
B			V						DA	P6	DA	P4		DA	P2	DA	N0																										B		
C								G		DA	P7	DA	P5		DA	N3	DA	N1																									C		
D	DA	N8	DA	P8	C		C			DA	N7	DA	N5		DA	P3	DA	P1																									D		
E		DA	N10	DA	P10	DA	P9	DA	N9																																		E		
F	V																																										F		
G		DA	N12	DA	P12	DA	P11	DA	N11																																			G	
H	V2		V2		DA	P13	DA	N13																																				H	
J		V																																										J	
K	DA	P14	DA	N14	DA	P15	DA	N15																																				K	
L		DB	P14	DB	N14	DB	P15	DB	N15																																			L	
M	V																																											M	
N		V2		V2		DB	P13	DB	N13																																			N	
P	DB	N10	DB	P10	DB	P11	DB	N11																																					P
R		V																																											R
T	DB	N10	DB	P10	DB	P9	DB	N9																																					T
U		DB	N8	DB	P8							DB	N7	DB	N5		DB	P3	DB	P1																								U	
V							EV				DB	P7	DB	P5		DB	N3	DB	N1																									V	
W		V		C		C				DB	P6	DB	N4		DB	P2	DB	N0																										W	
Y				V		V			DB	N6	DB	P4	V		DB	N2	DB	P0	V																									Y	
	40	39	38	37	36	35	34	33	32	31	30	29	28	27	26	25	24	23	22	21	20	19	18	17	16	15	14	13	12	11	10	9	8	7	6	5	4	3	2	1					

The vertical lines, which may occur due to improper connections between the panel and the PCB, occur with intervals of 50 inches(26mm). If vertical lines occur with intervals of more than 26mms, it indicates a failure of the DDP1011 IC itself. If they occur with intervals of less than 26mm, it means that more than two pins have bad connections.

DA,DB output wave
[Screen:WHITE]

Pin Name	Description	Pin Name	Description
V	Voltage : 3.3V	T	Test Point
V2	VCC2 : 8V	ME	Mirror Bias Extra
DA	A Channel Data Bus [When measured, there should be a waveform]	C	Clock
DB	B Channel Data Bus [When measured, there should be a waveform]	P#	A,B Channel Positive
NO.	MBRST# (Mirror Bias Rest) 26V	N#	A,B Channel Negative
G	The part from the present position to the GND (The black part is also a GND.)		

13-3-3 Description of Terminal Characteristics

Pin Name	Description
SCTRL_AN/P	A channel LVDS serial control
DCLK_AN/P	A channel LVDS CLOCK
SCTRL_BN/P	B channel LVDS serial control
DCLK_BN/P	B channel LVDS CLOCK
SCPDI	SERIAL CONTROL DATA INPUT
SCPDO	SERIAL CONTROL DATA OUTPUT
SCPENZ	SERIAL CONTROL ENABLE
SCPClk	SERIAL CONTROL CLOCK
DWRDN	DMD LOGIC RESET
MBRST(14:0)	MIRROR BIAS RESET
MBRST_EXTRA	UNUSED MIRROR BIAS RESET
EVCC	REFERENCE VOLTAGE DURING SPAM READ TEST OPERATION(NORMAL GND)
VCC2	MIRROR ELECTRODE VOLTAGE(8V)
VCC	LOGIC SUPPLY
VSS	LOGIC GROUND

13-3-4 Engine Failure Inspection Flow Chart for the DMD Board

No.	Description	Key Point	Remark
1	1) When the power cord is plugged in, 2) DC 300V~330V is automatically supplied to the ballast.	Check whether the DC330V (CN801 on SMPS) power is supplied to the ballast.	This voltage must be supplied to operate ballast and Lamp.
2	1) When the power key is pressed via the remote control, the micom of the analog board outputs high (5V) PWR signals. 2) The power board operates normally. 12V is supplied to the DMD CN101 terminal.	Check whether 12V is supplied to the CN101 terminal.	* 12V must be supplied to operate the motor.
3	1) The power good signal is supplied to pin no.2 terminal of the IC804 from the micom on the digital board and then the motor starts to drive. 2) If the color wheel rotates for a certain time and then stops, check whether the color wheel sensor is normal. (Check the waveform on the No.2 terminal below CN800.) 	After the set is powered on, check whether 5V is detected on pin No.2 of IC804. → After a while, the sound generated by the rotating color wheel is heard.	* If 5V is not detected, the motor will not operate.
4	1) Check whether the signal (SCI: START CONTROL INPUT) that turns on lamp #4 of CN802 on the DMD board is high (5V).	Check whether CN802 #4 signal is 5V.	* When SCI is high (5V), the lamp litz of CN803 is low (0V). * CN803 #4 terminal voltage changes to pulse wave form 14 seconds after (for 50 inch TV) the time that the voltage is 5V. * When about 4 seconds have passed after changing to pulse waveform, the screens are displayed on the set.

13-3-5 IC Line Up

1. Power Board

Items	Descriptions	Remarks
Main SMPS	FS7M0880, Fairchild	IC-PWM Controller ; Main Power
Stand-by SMPS [America]	KA1M0565, Fairchild	IC-PWM Controller ; Stand-by Power
Stand-by SMPS [Korea]	KA5M0165, Fairchild	IC-PWM Controller ; Stand-by Power

2. Digital Board

Items	Descriptions	Remarks
MPEG2 Decoder	X240H	CPU(MIPS), TS Demux, MPEG2 Decoder, Format converter, Deinterlacer, Scaler, USB
ADC HDMI Receiver	MST33389	ADC Digital Receiver for HDMI with HDCP
Video Enhance	SDP32	SAMSUNG RGB Processor
Program ROM	AT49BV + KFG5616U1M	8M + 32M, Nor + ONENAND Flash Memory
Frame Buffer	SDP32 SAMSUNG	RGB Processor
Program ROM	AT49BV x 2	32M(1M x 16) x 2, Nor-Type Flash Memory
Frame Buffer	64MB DDR, 16M Samsung	Frame Memory
LVDS Transmitter	DTC34LM85A	DOESTEK
VIDEO SWITCH	TEA6425	VIDEO SWITCH IC FOR TV (X2)
AUDIO SWITCH	TEA6422	AUDIO SWITCH IC FOR TV
SOUND MODULE	STV8258	DIGITAL AUDIO DECODER PROCESSOR
SOUND AMP	STA323W	DIGITAL AUDIO POWER AMPLIFIER
MICOM	S3F84BB	MICRO CONTROLLER

3. DMD Board

Items	Descriptions	Remarks
DMD Driver	DDP3021, TI	DLP Data Processor
Reset, Power	DAD2000, TI	DMD Power and Reset Driver
Power/Motor Controller	PMD1000, TI	12V VCM/Spindle Pre-Driver
Frame Buffer	MT49H8M36, MICOM	288M(8Mx), RCDRAM
Clock Generator	ICS640GI-41LF, IDT, TI	Spread spectrum Clock Generator
Program ROM	MX29LV320CBTC, macronix	32M(4Mx8 or 2Mx16), Flash Memory
LVDS Receiver	THC63LVD104, Thine	LVDS Digital Receiver, 75MHz

13-3-6 K520 Engine Ass'y

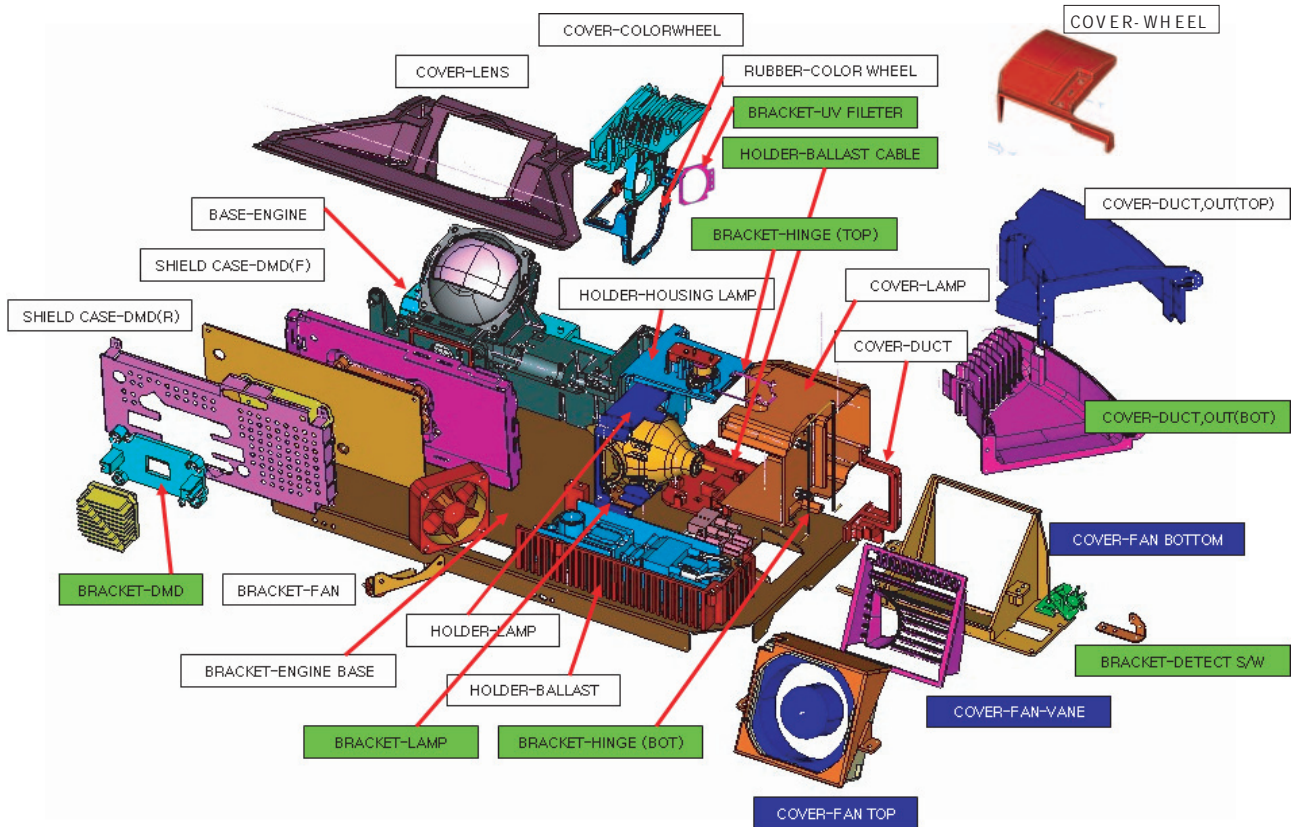

K520 Engine Exploded View List			
No.	Description	Specification	Q'ty
1	SHIELD CASE-DMD(F)	SECC, T1.0	1
2	SHIELD CASE-DMD(R)	SPTE, T0.5,DMD	1
3	BRACKET-FAN	SECC T1.0	1
4	BRACKET-ENGINE BASE	SECC,T1.6	1
5	HOLDER-HOUSING-LAMP	AL D/C	1
6	Cover-COLOR WHEEL	AL,T2.5,D/C	1
7	COVER-LENS	ABS,T2.5	1
8	HOLDER-LAMP	PPS G/F30, T2.5	1
9	COVER-LAMP	PPS G/F30, T2.5	1
10	COVER-DUCT TOP	PC+GF20% T2.5	1
11	COVER-DUCT BOTTOM	PC+GF20% T2.5	1
12	COVER-DUCT,OUT(TOP)	PC+GF20% T2.5	1
13	HOLDER-BALLAST	PC+GF20% T2.5	1
14	BASE-ENGINE	PC GF20% ,T2.5	1
15	HOLDER-BALLAST CABLE	PC GF20% ,T2.5	1
16	COVER-DUCT	PC GF20% ,T2.5	1
17	COVER-DUCT, RIGHT	PC GF20% ,T2.5	1
18	BRACKET-PANEL	AL D/C T3.5	1
19	HEATSINK-ES	AL	1
20	BRACKET-UV Filter	SUS, T0.3	1
21	BRACKET-LAMP	SUS, T0.5	1
22	BRACKET-DETECT S/W	SUS, T	1
23	COVER-DUCT,OUT(BOT)	PC+GF20% T2.5	1
24	BRACKET-HINGE TOP	SUS WIRE, 2.0	1
25	BRACKET-HINGE BOTTOM	SUS WIRE, 2.0	1
26	COVER-WHEEL	PC ABS, T2.5	1
27	RUBBER-COLOR WHEEL	Rubber	1

MEMO

14. Reference Information

14-1 Other issues related to other products

Problem	Descriptions
A fixed screen can cause permanent damage to the TV Braun tube.	Braun, PDP and LCD TVs can all be damaged. When a still image is displayed in a sequence, this can leave stains or after-images due to the characteristics of the panel. However, the DLP TV has the advantage that no stains or after-images are left on the screen. The DLP TV has mirror pixels on the DMD panel that project the beam onto the screen, in which the mirror is a digital representation of 0s and 1s, leaving no trace of light. The mirror returns to a blank state so that no stains or after-images are left.
Confusion between the ANYNET Port and the SERVICE Jack Port	The SAMSUNG SKY500N model has both an ANYNET port and a SERVICE jack port. Because the shape of the ANYNET port on the DLP TV is the same as that of the SERVICE jack port of the SKY500N, it fails to turn the TV off after a connection has been reported. The ANYNET port uses an RS232 port called Phone Jack, and the SERVICE jack port also uses the RS232 port. However, you must not connect the SERVICE port and the ANYNET port. Check if the port is the ANYNET port or the SERVICE port before connecting the port. Even if the TV cannot be turned on after connecting, the TV will turn on if you disconnect the connection.
Length of DVI Cable / PC RGB Cable	<ul style="list-style-type: none"> - A too long DVI cable may cause a malfunction or degradation of the visual quality due to an attenuation of the signal. There is no recommendation for the cable length at present. In general, although a cable length of up to 5 meters should work, please check if video is properly displayed on the screen after connecting. If you think the length of the cable is longer than for normal use, check the visual quality of the video on the screen and shorten the length, if necessary. - This also applies to the PC RGB (D-Sub) cable. When the length of the cable is longer than for normal use, video may not be displayed on the screen. In this case, shorten the cable length.
When a digitally distributed TV user receives HD-rated broadcasts:	The digital distributed TV (Ready Technique) can render HD sources as HD-rated. However, you need to install a set-top box for this purpose. The digital TV alone cannot render HD broadcasting as HD-rated. Install the formal set-top box for HD broadcasts.
When a digital distributed TV user selects normal size (4:3) to receive SD-rated digital broadcasts:	The digitally distributed TV (Ready Technique) renders any broadcasting service as SD-rated. However, when connected to a set-top box, the digital TV renders HD broadcasts as HD-rated and renders SD as SD-rated. The screen size is scaled to 4:3.
When a digitally built-in TV user receives SD (air) broadcasting:	The digitally integrated TV ("built-in" type) renders SD broadcasting as SD-rated. This can be understood easily. Even a high-resolution TV cannot improve a low resolution picture into high quality. In contrast, an SD-rated TV cannot represent HD broadcasting as HD because the resolution of the TV is lower than the original.
When selecting a picture size of 4:3 in connection with a computer or a multimedia device:	The representation capability of SD or HD-rated depend entirely on the TV set. The HD TV can render HD broadcasting as HD-rated only when it receives HD sources. In the meantime, the HD TV renders SD as SD-rated when it receives SD sources. The picture size has nothing to do with the resolution; TV models like SVP-XXL3HD or SVP-XXL6HD have a size adjustment feature to 16:9, ZOOM1, ZOOM2, ZOOM3, 4:3. This is about the aspect ratio of the top and bottom boundaries to the overall screen and users can select their preference.

■ SD/HD broadcasts and the TV's display capability are related

1. A digital broadcast should be transmitted in wide screen (an aspect ratio of 16:9) HD. If the broadcasting station converts a conventional program created in normal screen (aspect ratio of 4:3) into a digital signal and broadcasts the signal, the left and right of the picture will not be displayed.

This symptom also appears in other manufacturer's TV's. The three appliance companies are trying to resolve the problem through the Ministry of Information and Communication.

- * When watching an SD (normal) broadcast through a Digital (Wide) TV (480P normal broadcast)
- * When watching an SD (normal) broadcast through a Digital Ready (Wide) TV (Using a set-top-box)
- * When watching an analog (normal) broadcast through a wide TV
(When watching a broadcast after changing the aspect ratio of the TV from 16:9 (wide screen) to 4:3)

2. When watching a DVD title or video tape in wide screen (21:9) through a wide (16:9) TV, watching video from a computer or game console by selecting the aspect ratio to 4:3, or watching video from a DVD, VCR, computer or game console through a wide TV by selecting the aspect ratio to normal (4:3) or wide (21:9), the left and right, or top and bottom of the picture will not be displayed.

This symptom appears in other manufacturer's TV's. The three appliance companies are trying to resolve the problem through the Ministry of Information and Communication.

■ Changing the Order of the Picture Size for 16:9 Display Devices

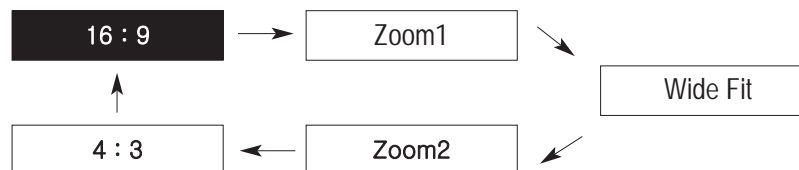

■ Changing the Order of the Picture Size for DTV 1080i/720p Sources



■ Restrictions

1. When you want to change the picture size in PIP 'ON', you must turn the PIP off before changing the size. However, you can change the main picture size even in PIP ON for products with no restrictions.
2. When the picture size is not Normal (4:3 for 4:3 display devices, 16:9 for 16:9 display devices) and you turn PIP on, the picture size is changed to Normal. However, you can turn PIP on without changing the picture size for products with no restrictions.
3. In the OSD notation for the picture size, 16:9 is represented as "Wide" instead of "16:9" for devices other than with 16:9 displays.
Ex: For LCD 15:9 devices, "Wide" is displayed on the OSD instead of "16:9".
4. The picture size can be changed even in the blue screen. However, the picture size should be controlled by the product specifications if the change is impossible due to hardware restrictions.

14-2 Technical Terms

PIP (Picture In Picture)

A feature to enable two video images being displayed on one screen at the same time. For instance, you can see the TV channel and the video image at the same time.

Digital Broadcasting

The ATSC (Advanced Television Systems Committee) signals that the station digitalizes before transferring the audio/video signals.

Mono

A sound system that transmits voice signals in only one channel. It is hard to experience a 3D effect but can be run with one speaker.

LNA (Low Noise Amplifier)

This uses satellite technologies to amplify weak signals for improved quality even in poor reception areas.

Stereo

A sound system that transmits voice signals in two channels. This implements 3D effects by transmitting to both speakers (left/right).

Analog Broadcasting

The conventional system in which the station transfers the audio/video signals in NTSC formats.

Antenna Terminal

A terminal which the TV antenna is connected to. A round coaxial cable is connected to this terminal, which is usually used to watch air broadcasts.

English Captions (Subtitle)

A feature to provide English captions or character information services, which the user can use to study English using AFKN broadcasting or video tapes marked with "CC".

Audio/Video Terminal

The old 3- or 4-channel TV with no AV terminal has a low quality issue for video tape. The problem can be resolved using an A/V terminal that separates the audio and video signals. The video terminal is in yellow; the audio terminal is divided in two, white for left and red for right.

External Source

This includes sources from the video recorder, DTV set-top box and DVD player, (anything but the TV).

DVI-I Cable

One of the DVI cables that can transfer both digital and analog signals.

Satellite Broadcasting

This uses a satellite system to support a maximum of 100 channels including air services and provides high quality pictures anywhere in the country, even in poor reception areas. A set-top box (unbundled) is required to watch satellite broadcasting.

Closed Broadcasting

Other than VHF and UHF, this includes movies, entertainment and educational programs broadcast by hotels or schools. This is different from cable broadcasting.

Multiplexing

Two languages are provided at the same time when broadcasting foreign movies, dramas and news programs. You can choose either a native or foreign language, or choose both at the same time.

Component Terminal (Green, Blue, Red)

This provides maximum quality by dividing the contrast signals before transferring.

Cable Broadcasting

Compared to air broadcasting, it uses the cable system to transfer the signals. You should subscribe to a local cable broadcasting company and install a separate receiver.

Tuner

A device used to select a particular frequency from the TV set or the radio receiver.

Anynet

An AV networking system of Samsung's various AV devices, which enables the user to conveniently control AV devices using the TV.

DVD (Digital Versatile Disc)

This is a CD-sized, high storage disk that can store multimedia data including videos, games and audio applications using MPEG-2 compression technology.

DVI (Digital Visual Interface) Terminal

This is a digital signaling standard.

This uses TMDS to reduce the signal loss rate for sharper images.

DVI-D Cable

One of the DVI cables that can only transfer digital signals.

HDMI (High Definition Multimedia Interface)

An interface into which the digital signals as well as the high quality image data can be connected with one cable. There is no need to compress the bit rate.

S-video Terminal

This is, called "Super-video", divided into video and color signals for sharper image display.

VHF/UHF

VHF refers to the 2 - 13 channel system; UHF indicates the 14 - 69 channel system.