

CONTENTS

X-RAY RADIATION PRECAUTION.....	1
SAFETY PRECAUTION.....	1
PRODUCT SAFETY NOTICE.....	2
GENERAL INSTRUCTION.....	2
ALIGNMENT ITEMS AND PROCEDURE.....	2
FACTORY ADJUSTMENT MODE.....	4
ADJUSTMENT METHOD.....	4
CHECKING POINTS.....	6
OUT-FACTORY MODE PRESET.....	7
POWER ADAPTABILITY CHECK.....	7
USA CHANNEL FREQUENCY TABLE (181 CH).....	16
WIRING DIAGRAM.....	18
BLOCK DIAGRAM.....	19
IC BLOCK DIAGRAM.....	20
COMPONENT AND BOTTOM VIEW.....	28
SCHEMATIC DIAGRAM.....	31
ELECTRICAL PARTS LIST.....	33

CAUTION: THIS SERVICE MANUAL IS ONLY FOR PROFESSIONAL SERVICE PERSONNEL'S REFERENCE. BEFORE SERVICING THIS CHASSIS, PLEASE READ THE FOLLOWING NOTICE ITEMS.

1. SAFETY INSTRUCTION AND GENERAL INSTRUCTION

Before servicing and aligning this equipment, please read the following “**X-RAY RADIATION PRECAUTION**”, “**SAFETY PRECAUTION**” and “**PRODUCT SAFETY NOTICE**”.

1.1 X-RAY RADIATION PRECAUTION

- 1) Excessive high voltage can produce potentially hazardous X-RAY RADIATION. To avoid such hazards, the high voltage must not be above the specified limit. The normal value of the high voltage of this receiver is under 32 kV at zero beam current (minimum brightness) under DC135V main power(B+) , the high voltage must not, under any circumstances, exceed 35 kV.
- 2) Each time a receiver requires servicing, the high voltage should be checked following the HIGH VOLTAGE CHECK procedure in this manual. It is recommended the reading of the high voltage be recorded as a part of service record. It is important to use an accurate and reliable high voltage meter.
* When checking, main power (B+) should be kept at 135 V (for Toshiba pure flat CRT).
- 3) The primary source of X-RAY RADIATION in this TV receiver is the picture tube. For continuous X-RAY RADIATION protection, the replacement tube must be exactly the same type tube as specified in the parts list.
- 4) Some parts in this receiver have special safety-related characteristics for X-RAY RADIATION protection. For continuous safety, parts replacement should be undertaken only after referring to the PRODUCT SAFETY NOTICE below.

1.2 SAFETY PRECAUTION

WARNING:

Service should not be attempted by anyone unfamiliar with the necessary precaution on this receiver. The following are the necessary precautions to be observed before servicing this chassis.

- 1) Since the power supply circuit of this receiver is directly connected to the AC power line, an isolation transformer should be used during any dynamic service to avoid possible shock hazard.
- 2) Always discharge the picture tube anode to the CRT conductive coating before handling the picture tube. The picture tube is highly evacuated and if broken, glass fragments will be violently expelled. Use shatter proof goggles and keep picture tube away from the unprotected body while handling.
- 3) When replacing a chassis in the cabinet, always be certain that all the protective devices are put back in place, such as: non-metallic control knobs, insulating covers, shields, isolation resistor-capacitor network etc.
- 4) When replacing parts or circuit boards, disconnect the power cord.
- 5) When replacing a high wattage resistor (oxide metal film resistor) on the circuit board, keep the resistor 10mm (1/2in) away from circuit board.
- 6) Connection wires must be kept away from components with high voltage or high temperature.

7) If any fuse in this TV receiver is blown, replace it with the FUSE specified in the chassis parts list.

1.3 PRODUCT SAFETY NOTICE

Many electrical and mechanical parts in the chassis have special safety-related characteristics. These characteristics are often passed unnoticed by a visual inspection and the X-RAY RADIATION protection afforded by them cannot necessarily be obtained by using replacement components rated for higher wattage, etc. Replacement parts which have these special safety characteristics are identified in this manual and its supplement electrical components having such features are shaded on the schematic diagram and the parts list.

Before replacing any of these components, read the parts list in this manual carefully. The use of substitute replacement parts which do not have the same characteristics as specified in the parts list may create shock, fire, X-RAY RADIATION or other hazards.

1.4 General instruction

1.4.1 This chassis' EEPROM(N801 M24C08) should copy standard data first, if necessary, deal it with "factory adjustment". If directly use blank EEPROM, should first preset I²C data, then go on other common alignment. For factory adjustment method, refer to **The appendix: Factory adjustment mode**.

1.4.2 If without special indication, the alignment is conducted on the below condition:

- a) AC power supply 120 V/60 Hz.(North America area) or others (depending on selling market).
- b) The whole unit is preheated for more than 30 min.

1.4.3 There is built-in auto degaussing circuit, it will degauss automatically within 1second after turning on. And the auto degaussing circuit can effect only when turning off the set and waiting for at least 30min and then turning on.

1.4.4 If CRT is with magnetism and affects color purity and convergence, the internal degaussing can not degauss completely, can use degaussor to degauss externally. If color purity and convergence is still poor, then do color purity and convergence adjustment.

2 Alignment items and procedure

- 2.1 B+ voltage check
- 2.2 OSD character center adjustment
- 2.3 RFAGC voltage adjustment
- 2.4 Focus adjustment
- 2.5 Screen-grid voltage and white balance adjustment
- 2.6 SECAM colour adjustment
- 2.7 Horizontal, vertical scanning center adjustment
- 2.8 Horizontal, vertical scanning amplitude adjustment
- 2.9 Raster correction adjustment
- 2.10 The alignment flow chart see below figure.

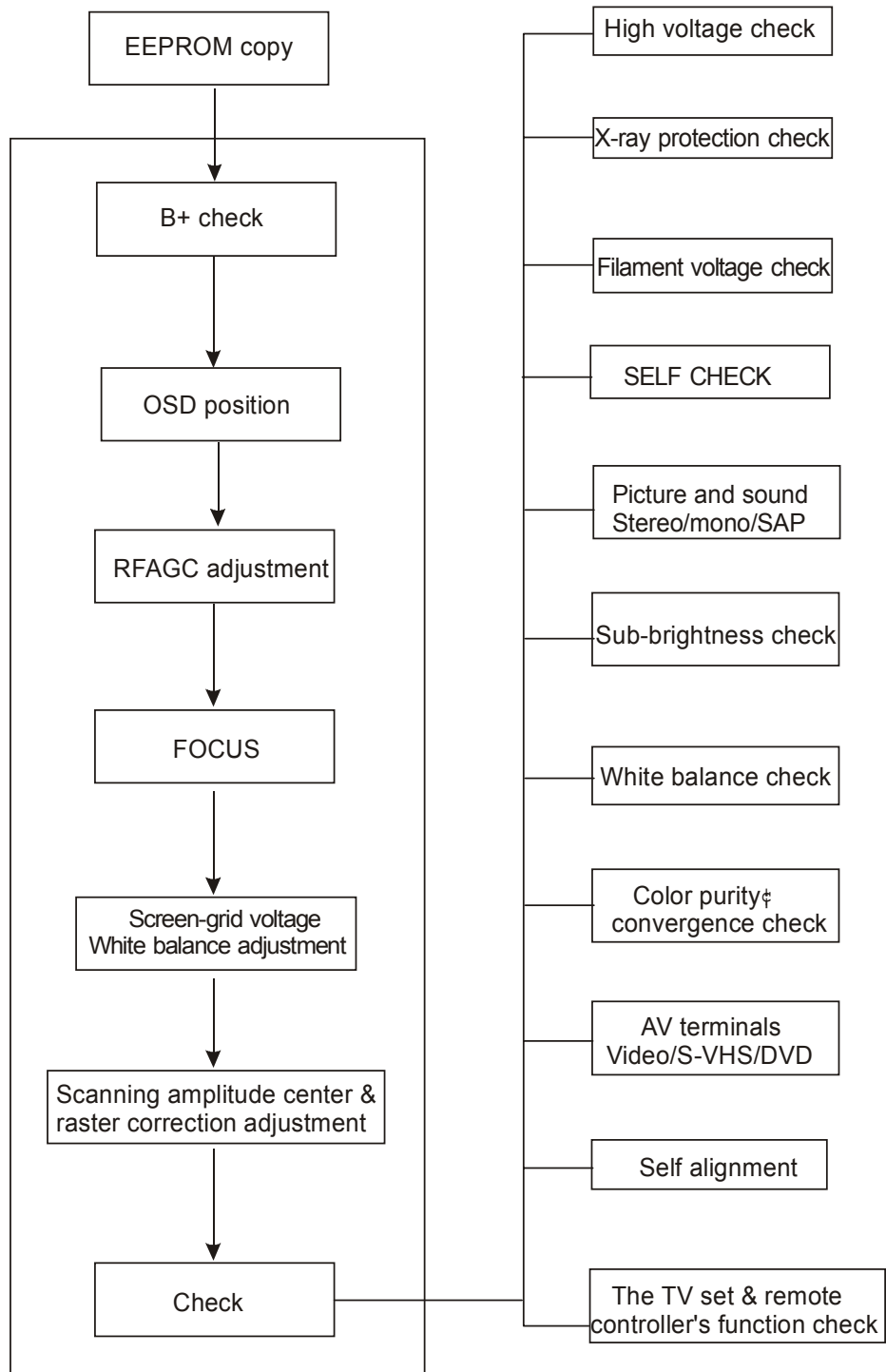

Figure 1: Alignment flow chart

3 Factory adjustment mode

3.1 Enter into factory adjustment menu

Press SLEEP→PIC→DSP→MENU button on the remote controller in order (the period of two press should be less than 5 seconds), the screen will appear factory alignment menu.

3.2 Factory menu operation

Repeatedly press "MENU" button, then the menu will enter into PAGE 1→PAGE 2→PAGE 3→PAGE 4→PAGE 5 and recycle; press ▲ or ▼ button can select adjustment items upward or downward, and press ◀ or ▶ button to confirm or adjust the item's value.

3.3 To exit the factory menu

Press "SLEEP" button to exit the factory adjustment menu.

4 Adjustment method

4.1 B+ voltage adjustment

- a) Make sure the power supply is AC120 V/60 Hz(for America or Canada area).
- b) Connect the digital voltmeter to B+ testing point, receive A7 signal, set the picture control to "NATURAL" status, adjust RP501 to make B+ voltage be $135\text{ V}\pm 0.3\text{ V}$ (just for TOSHIBA pure flat CRT, as regards to other CRT, B+ value will be marked on the parts list.)
- c) In STAND BY mode, the B+ voltage will be about 84 V.

4.2 OSD position adjustment

Receive NTSC signal, change the factory adjustment menu page 3 OSD item's value to make user's menu be in screen's center position.

4.3 AGC adjustment

- a) Receive 60 dB split field (or grey-scale) signal.
- b) Use oscilloscope or digital voltmeter to monitor tuner 1 pin's voltage (RFAGC pin).
- c) Select factory adjustment menu page 4 R-AGC item, making use of [←][→] button to increase the value from down to up until the voltage just reach 4.0 V, at this time picture noisy spots should disappear basically. Otherwise continue to fine tune R-AGC item.
- d) Exit the factory menu.

4.4 Focus adjustment

4.4.1 Receive A12 signal, set picture mode to "MEMORY 2" status.

4.4.2 Adjust FBT FOCUS potentiometer to make screen's B area's focus optimum.

4.5 Screen-grid voltage, white balance adjustment

4.5.1 Receive A7 split field signal, set picture mode to "MEMORY 3" status.

4.5.2 Keep RCUT's value, not change it (for example set it to 60), roughly adjust GCUT and BCUT value to make white balance basically normal.

4.5.3 Set colour, contrast to minimum, set brightness to 50. Use oscilloscope to monitor CRT board red gun waveform, adjust PAGE 4 BRTS value to make black level be 180 V.

4.5.4 Adjust SCREEN (accelerating electrode) potentiometer to make picture brighten 4 lattices.

4.5.5 Fine adjust white balance (colour temperature: $12000\text{K}\pm 8\text{MPCD}$ X= 0.270 ± 0.008 Y= $0.283\pm$

0.008).

4.5.6 Adjust PAGE 2 BRTN value to make colour ,brightness,contrast all be minimum, picture " white block " slightly lights up.

4.6 Horizontal,vertical scanning center adjustment

4.6.1 PAL(50 Hz)horizontal,vertical center adjustment

Receive G23 signal, set picture mode to "MEMORY 2 " status, fine tune vertical center VP50, horizontal center HPOS, to make picture center be in accordance with screen center.

4.6.2 NTSC (60 Hz) H-center,V-center adjustment

Receive A6 signal, set picture mode to "MEMORY 2 " status, adjust V-center VP60, H-center HPS, to make picture center be in accordance with screen center.

4.7 Vertical scanning amplitude adjustment

4.7.1 PAL (50 Hz) vertical amplitude adjustment

Receive D35 signal, set picture mode to "MEMORY 2 " status, adjust vertical amplitude HIT, to make picture up/down overscanning be screen size's 8%.

4.7.2 NTSC (60 Hz) vertical amplitude adjustment

Receive A12 signal, set picture mode to "MEMORY 2 " status, adjust V-amplitude HITS, to make picture up/down overscanning be screen size's 8%.

4.8 Raster correction adjustment,H-amplitude adjustment

4.8.1 PAL(50 Hz)raster correction adjustment ,H-amplitude adjustment.

Receive PAL white crosshatch signal, set picture mode to "MEMORY 2 " status, adjust DPC to make raster distortion be in minimum, adjust WID to make picture left/right overscanning be screen size's 8%.

4.8.2 NTSC(60 Hz)raster correction adjustment

Receive NTSC A21 signal, set picture mode to "MEMORY 2 " status, adjust DPCS to make raster distortion minimum, adjust WIDS to make picture left/right overscanning be screen size's 8%.

4.9 If scanning linearity distortion and raster geometrical distortion can not reach the requirements, and if necessary, can make use of factory adjustment menu to adjust the following items:

VLIN	V-linearity adjustment(PAL)
VLIS	V-linearity adjustment (NTSC)
VSC	Vertical S-correction adjustment (PAL)
VSS	Vertical S-correction adjustment (NTSC)
CNRT	Top corners' correction
CNRB	Bottom corners' correction
KEY	Trapezoid correction (PAL)
KEYS	Trapezoid correction(NTSC)

4.10 Maximum sound output power

Receive single tone signal, set volume to maximum, the sound output power is 2×8 W. (can fine adjust factory menu V100)

5 Checking points

5.1 High voltage check

5.1.1 Connect high voltmeter to CRT second anode and GND.

5.1.2 Receive A7 signal, set picture mode to "MEMORY 2" status, measure the high voltage value, the reading should be 30.0 kV±1 kV.

5.1.3 When setting brightness and contrast to minimum(zero beam current))measure the high voltage value, the reading should not exceed 32 kV.

5.2 CRT filament voltage check

Receive A7 signal, set picture mode to "NATURAL" status, use effective value voltmeter to measure CRT filament voltage, the reading should be (6.3±0.3)Vrms.

5.3 X-ray protection check

5.3.1 Receive A7 signal, set picture mode to "MEMORY 2" status.

5.3.2 Short S301, X-ray protection circuit should effect.

5.4 "Self-check" function check

Press "SELF-CHECK" button, the screen will display the following information:

		M
SELF	CHECK	
BUS	LINE:	OK
BUS	CONT:	OK
SYNC:		OK

"OK" means bus,SYNC status, etc are normal.

If display "SCL-GND", means SCL short to GND. ;

"SDA-GND" means SDA short to GND.

"SCL-SDA" means SCL short to SDA.

5.5 Picture and sound check

5.5.1 Receive standard TV signal.

5.5.2 Make use of picture control buttons to check colour,contrast,brightness,sharpness,tint's control function.

5.5.3 Make use of sound control buttons to check sound control function.

5.6 Sub-brightness check.

Receive A7 signal, set colour,contrast,brightness all to 0, picture left one lattice slightly lights up.

5.7 This set can produce 14 kinds of testing signals by itself. In factory menu when select some adjustment item, every press of AV button for one time, it will produce one testing signal.

5.8 Colour purity and convergence check (in normal way)

5.9 AV terminal input/output check

5.10 Other control buttons on the set/remote controller function check

6 Out-factory mode preset

Press "SHOP OUT " button, out-factory status will be preset to:

6.1	Picture menu:	Colour	70
		Brightness	70
		Contrast	100
		Sharpness	50
		Tint	50
		Blue background	On
6.2	Volume preset to:	30	
6.3	Language menu:	ENGLISH	
6.4	Colour system :	AUTO	
6.5	NOISE REDUCE:	OFF	
6.6	TV mode:	Channel positionA2	
6.7	SVM:	MILD	
6.8	V-CHIP PASSWORD:	0000	
6.9	CHILD LOCK MENU		
	PASSWORD:	0000	
6.10	SOUND MODE:	MEMORY 1	
6.11	TV/CATV CHANNEL:	Both set to ADD	
6.12	CCD CHANNEL:	Set to C1	
6.13	V-OHIP:	Set all ratings and contents to IGNORE	
6.14	V-CHIP BLOCK ON/OFF:	Set to ON	

7 Power adaptability check

AC 120 V/60 Hz (for North America area. If have other special AC power supply requirements, then check with requirements).

Appendix1 factory adjustment menu

Item NO.	OSD character	Preset	Adjustment item	Analogue setting	Input signal	Adjustment method	Testing point
1	HPOS	OF	50Hz H-center	MEMORY 2	D35	To make picture horizontal center be in accordance with CRT center	Screen
2	WID	16	50Hz H-amplitude	MEMORY 2	D35	To make horizontal amplitude meet standard	Screen
3	VP50	06	50Hz V-center	MEMORY 2	D35	To make picture vertical center be in accordance with CRT center	Screen
4	VLIN	0E	50Hz V-linearity	MEMORY 2	D35	To make upper, lower crosshatch height be equal.	Screen
5	VSC	07	50Hz vertical S-correction	MEMORY 2	D35	To make upper, middle, lower crosshatch height be equal.	Screen
6	HIT	2B	50Hz V-amplitude	MEMORY 2	D35	To make Vertical amplitude meet standard	Screen

7	KEY	22	50Hz trapezoid correction	MEMORY 2	D35	To correct picture trapezoid	Screen
8	DPC	18	50Hz pincushion correction	MEMORY 2	D35	To correct picture E/W pincushion	Screen
9	CNRT	08	Top edge and corner correction	MEMORY 2	D35/A12	To correct top edge and corner vertical line	Screen
10	VEHT	05	Vertical high voltage compensation	MEMORY 2	D35/A12	fix	Screen
11	HPS	04	60Hz H-center	MEMORY 2	A12	To make picture horizontal center be in accordance with CRT center.	Screen
12	WIDS	FD	60Hz H-amplitude	MEMORY 2	A12	To make horizontal amplitude meet standard.	Screen
13	VP60	02	60Hz V-center	MEMORY 2	A12	To make picture vertical center be in accordance with CRT center.	Screen
14	VLIS	FF	60Hz V-linearity	MEMORY 2	A12	To make upper, lower crosshatch height be equal	Screen
15	VSS	FE	60Hz vertical S-correction	MEMORY 2	A12	To make upper, middle, lower crosshatch height be equal.	Screen
16	HITS	FD	60Hz V-amplitude	MEMORY 2	A12	To make vertical amplitude meet standard	Screen
17	KEYS	01	60Hz trapezoid correction	MEMORY 2	A12	To correct picture trapezoid	Screen
18	DPCS	FF	60Hz pincushion correction	MEMORY 2	A12	To correct picture E/W pincushion	Screen
19	CNRB	07	Bottom edge and corner correction	MEMORY 2	D35/A12	To correct bottom edge and corner vertical line	Screen
20	HEHT	02	Horizontal high voltage compensation	MEMORY 2	D35/A12	Fix	Screen
21	RCUT	60	Dark area white balance		Black/white signal or A7 signal	To make picture dark area to obtain standard "white colour"	Screen
22	GCUT	60					
23	BCUT	60					
24	GDRV	30	Bright area white balance	MEMORY 1	Black/white signal or A7 signal	To make picture bright area to obtain standard "white colour"	Screen
25	BDRV	30					
26	CNTX	4E	Contrast maximum value setting	MEMORY 1	Gray scale	Fix	Screen
27	CNTC	30	Contrast middle value setting	Contrast 50	Gray scale	Fix	Screen
28	CNTN	18	Contrast minimum value setting	Contrast 0 Colour 0 Brightness 50	Gray scale	Fix	Screen
29	BRTX	70	Brightness maximum value setting	Contrast 50 Brightness 100 Colour 0	A7 signal	Fix	Screen
30	BRTC	50	Brightness middle	Contrast 0	A7 signal	Fix	Screen

			value setting	Brightness 50 Colour 0			
31	BRTN	2C	Brightness minimum value setting	Contrast 0 Brightness 0 Colour 0	A7 signal	Refer to adjustment method	Screen
32	COLX	4F	Colour maximum value setting	MEMORY 1	A7 signal	Fix	Screen
33	COLC	38	Colour middle value setting (NTSC)	MEMORY 2	A7 signal	Fix	Screen
34	COLP	38	Colour middle value setting (PAL)	MEMORY 2	AV(PAL)	Fix	Screen
35	COLN	00	Colour minimum value setting	Contrast 100 Brightness 50 Colour 0	A7 signal	To make picture without colour	Screen
36	TNTX	6F	NTSC tint maximum value setting	Contrast 100 Tint 100 brightness70 colour 70	A7 signal	Fix	Screen
37	TNTC	38	NTSC tint middle value setting	MEMORY 2	A7 signal	Fix	Screen
38	TNTN	00	NTSC tint minimum value setting	Contrast 100 Tint 0 brightness70 colour 70	A7 signal	Fix	Screen
39	SCOL	04	Sub-colour adjustment	MEMORY 2	A7 signal	Fix	Screen
40	SCNT	0F	Sub-contrast adjustment	MEMORY 2	Gray scale	Fix	Screen
41	ASSH	00	Non-symmetry sharpness			Fix	Screen
42	ABL	27	ABL control(refer to appendix 2 for details)	MEMORY 1	A7 signal	Fix	Screen
43	DEF	01	Set interlace scan to 01	MEMORY 2	A7signal	Fix	Screen
44	FLG 0	52	Refer to appendix 2 for details			Fix	Screen
45	FLG 1	05	Refer to appendix 2 for details			Fix	Screen
46	STBY	00	Refer to appendix 2 for details			Fix	Screen
47	TNCD	40	Tint center(DVD)			Fix	Screen
48	VBLK	00	Refer to appendix 2 for details			Fix	Screen

49	MOD	03	Refer to appendix 2 for details			Fix	Screen	
50	UCOM	80	Refer to appendix 2 for details			Fix	Screen	
51	MODE 3	80	Refer to appendix 2 for details			Fix	Screen	
52	OPT	17	Refer to appendix 2 for details			Fix	Screen	
53	OPTM 1 (Refer to appendix 2 for details)	A2	MTS/no GAME			Fix	Screen	
		A6	MTS/ GAME					
		22	No MTS/no GAME					
		26	No MTS/ GAME					
		A0	MTS/no GAME/AV3					
		A4	MTS/GAME/AV3					
54	OPTM 2 (Refer to appendix 2 for details)	C5	Rotation/P4.43/N4.43 /M-N		RF:N▲AV: P/N	Fix	Screen	
		85	Rotation/N-M/P-M/P -N					South America tri-system
		45	No rotation /N-M/P-4.43/ N-4.43					RF:N;AN:P /N
		05	No rotation /N-M/P-M/P-N					South America system
55	TUNR	02	Tuner select			Fix		
56	OSD	18	OSD horizontal position setting		Any TV signal display MENU content	Character in screen center	Screen	
57	OSDF	55	OSD oscillation frequency			Fix		
58	CCD OSD	16	CCD horizontal position setting		Display CCD caption	CCD character be in screen center	Screen	
59	CCD OSDF	50	CCD OSD oscillation frequency			Fix		
60	ST3	20	NTSC3.58 TV input's sub-sharpness middle value	MEMORY 2	A12	Fix	Screen	
61	SV3	30	NTSC3.58 AV input's sub-sharpness middle value	MEMORY 2	AV-N3.58	Fix	Screen	

62	SV4	30	Non NTSC3.58 AV input's sub-sharpness middle value	MEMORY 2	AV-P4.43 N4.43	Fix	Screen
63	SVD	30	DVD input's sub-sharpness middle value	MEMORY 2	DVD	Fix	Screen
64	SHPX	1A	Sharpness maximum value setting	Sharpness 100	A12	Fix	Screen
65	SHPN	1D	Sharpness minimum value setting	Sharpness 0	A12	Fix	Screen
66	TXCX	1F	DVD sub-colour maximum value	MEMORY 1	DVD	Fix	Screen
67	RGCN	1F	DVD sub-colour minimum value	MEMORY 2	DVD	Fix	Screen
69	CLTM	0F	Refer to appendix 2 for details	MEMORY 2	A12	Fix	Screen
70	CLVO	4F	Refer to appendix 2 for details	MEMORY 2	AV signal	Fix	Screen
71	CLVD	58	Refer to appendix 2 for details	MEMORY 2	DVD signal	Fix	Screen
72	BRTS	20	Sub-brightness	Contrast 0 Brightness 50 Colour 0	Gray scale	Refer to alignment method	Screen
73	RAGC	30	RF AGC	MEMORY 2	A7	Refer to alignment method	Screen
74	HAFC	05	AFC gain			Fix	Screen
75	VCEN	00	IC output vertical signal center			Fix	
76	NSHP	10	Noise reduction degree	MEMORY 2		Fix	Screen
77	SYCT	08	(TEST)			Fix	
78	NOIS	01	(TEST)			Fix	
79	ONTM	00	POWER ON MUTE TIMER			Fix	
80	V25	36	VOL-25% volume setting	VOL-25	Single tone signal	Fix	
81	V50	40	VOL-50% volume setting	VOL-50	Single tone signal	Fix	
82	V100	76	VOL-100% volume setting	VOL-100	Single tone signal	Refer to adjustment methods	
83	SUR 1	03	At sound register 1's surround sound data			Fix	Not use

84	BASC	30	Bass middle value setting	VOL-50	Sound sweep frequency signal	Fix	
85	BASX	40	Bass maximum value setting	VOL-50		Fix	
86	TREC	39	Treble middle value setting	VOL-50		Fix	
87	BALC	43	Balance center value setting	VOL-50		Fix	
88	WOFC	3D	Woofers middle value setting			Fix	Not use
89	BAS 1	32	At sound register 1's bass data	VOL-50		Fix	
90	BAS 2	5A	At sound register 2's bass data	VOL-50		Fix	
91	TRB 1	32	At sound register 1's treble data	VOL-50		Fix	
92	TRB 2	28	At sound register 2's treble data	VOL-50		Fix	
93	WCTL	30	Woofers control			Fix	Not use
94	WON 1	00	At sound register 1's "woofers on "			Fix	Not use
<p>Note 1: firstly adjust PAL signal (D35) then adjust NTSC signal (A12) and then recheck PAL signal (D35) again, prior to guarantee NTSC signal raster.</p> <p>Note 2: when checking PAL system colour, inputting signal is AV signal.</p>							

Appendix 2: factory adjustment menu remarks

OPTM 1	Bit 0	FJP-SVM USE	0:SVM OUT	1:MONITOR OUT
	Bit 1	AV SELECT	0:AV1-AV2(DVD)-AV3	1:AV1-AV2-DVD
	Bit 2	FJP-GAME	0:without GAME	1: has GAME
	Bit 3	On-timer indication	0:low level, On-timer ON	1: high level, On-timer ON
	Bit 4			
	Bit 5			
	Bit 6	FJP-M-PAL	0;others	1: Only PAL-M
	Bit 7	FJP-stereo	0: without stereo	1: have stereo
OPTM 2	Bit 0	FJP-Y.U.V	0: without Y.U.V	1: have Y.U.V
	Bit 4	FJP-display button	0: timer display OSD	1: always display
	Bit 5	FJP-woofers	0:without woofers	1: have woofers
	Bit 6	FJP-AUDO 1	0:AUDO 2(35N,M-PAL,N-PAL)	1:AUDO 1(44P,35N,SECAM,44N)
	Bit 7	FJP-rotation	0: without rotation	1: have rotation

ABL	Bit 1,0	ABL gain	00:-0.17V;01:-0.35V;	10:-0.50V;11:-0.65V;
	Bit 3,2	ABL starting point	00:0V;01:-0.15V;	10:-0.28V;11:-0.38V
	Bit 4	2IN1 VCD-WPS	0:white peaking value is limited at 105 IRE	1: no limitation to white peaking value
	Bit 5	2IN1 VCD-PGB ABL	0:ABCL has function to OSD	1: without function
FLG 0	Bit 0	OVER MODE SWITCH	0; normal	1:PIF over-modulation switch is connected .
	Bit 1	AFT window	0:OUT OF AFT WINDOW	1:IN THE AFT WINDOW
	Bit 2	Buzz reduction	0:NYQUIST BUZZ CANCEL ON	1:OFF
	Bit 3	Orthogonal detection gain	0: not use	1: not use
	Bit 4	LOCAL SECAM	0: not use	1: not use
	Bit 5	5.65MHz SIF	0: not use	1: not use
	Bit 6	5.74MHz SIF	0: not use	1: not use
	Bit 7	Frequency select no need VCO adjustment	0: have VCO	1: without VCO
FLG 1	Bit 0	CW on/off	0:OFF	1:ON CW OUTPUT FROM IC-26#
	Bit 1	Y OUT ON	0: not use	1: not use
	Bit 2	MIZ GAIN	0:SIF 1MHz CONVERT GAIN, LOW GAIN	1:HIGH GAIN
	Bit 5	C TRAP PASS (TEST)	0: not use	1: not use
	Bit 6	Detection NTSC 3.58	0: not use	1: not use
	Bit 7	TELETEXT	0: not use	1: not use
	MOD	Bit 0	CUT OFF gain X10	00:AKB CUT OFF sensitivity X9.75
Bit 1		01:X10		11:X10.50
Bit 2		CO MAX	0:CUT OFF range-0.65 TO +6.5	1:-0.65 TO +0.85
VCOM [CHROMA S/N] (80)	Bit 0	Inner ADC	00:GND	10:B OUT
	Bit 1		01:R OUT	11:MONITOR RF AGC VIA ADC
	Bit 2	REST PATTERN FROM UCOM	0: normal	1:
	Bit 3	USE UCOM SYNC SWITCH	0: normal	1:USE U-COM SYNC
	Bit 4	SYNC TO UCOM	0: not use	1: not use
	Bit 5	V-SWITCH OUT UCOM	0: not use	1: not use
	Bit 6			
	Bit 7	OSD HD input polarity selection	0: not use	1: always setting 1
MODE 3	Bit 4-0	VIDEO MUTE time	MUTE time =data×8 ms	
	Bit 7	VIDEO MUTE type	0:Y MUTE	1:RGB OUT CUT OFF DC

OPT	Bit 0	FBB-MUTE	0:	1: when blue background off, not do MUTE
	Bit 1	FBB-EXMUTE	0:	1: when blue background off, not do EXT-MUTE
	Bit 2	FYMUTE USE	0:	1: when switching channels, use Y-MUTE
	Bit 3	Sound gain SW	0:50Hz	1:500mVrms-25kHz/dev
	Bit 4	Vertical frequency force	0:50Hz	1:60Hz
	Bit 5	SYNC detection way	0: external	1: internal
	Bit 6	Not use		
	Bit 7	SYNC distinguish way	0:	1: gain noise detection
DCBS	Bit 0	Black level stretching point	00:	10:33 IRE
	Bit 1		01:25 IRE	11:43 IRE
	Bit 2	Y-GAMMA	00:OFF	10:82 IRE
	Bit 3		01:Y γ 90 IRE , - 3dB	11:75 IRE
	Bit 4	OSD level	00:80 IRE	10:60 IRE
	Bit 5		01:70 IRE	11:50 IRE
CLTM [in TV mode]	Bit 0	Y delay (in TV mode)	000:-40ns	100:120ns
	Bit 1		001:0	101:160ns
	Bit 2		010:40ns	110:200ns
			011:80s	111:240ns
	Bit 3	NTSC matrix	00:NTSC 1(93°)	10,11:FOR DVD
	Bit 4		01:NTSC 2(108°)	
	Bit 5	C-GAMMA	0: Chroma γ correction off	1: chroma γ correction on(in effect)
	Bit 6	Color killer off	0: normal	1: color killer always off (always have color)
Bit 7	P/N ID	0:P/N color killing sensitivity 1.2/1.5mVp-p	1:6.6/6.4 mVp-p	
CLVO [in AV mode]	Bit 0	Y delay (in AV mode)	000:-40ns	100:120ns
	Bit 1		001:0	101:160ns
	Bit 2		010:40ns	110:200ns
			011:80ns	111:240ns
	Bit 3	NTSC matrix	00:NTSC 1(93°)	10,11:FOR DVD
	Bit 4		01:NTSC 2(108°)	
	Bit 5	C-GAMMA	0: chroma γ correction off	1: on
Bit 6	Color killer off	0: normal	1: color killer always off (always have color)	
Bit 7	P/N ID	0:P/N color killing sensitivity 1.2/1.5mVp-p	1:6.6/6.4 mVp-p	

CLVD [in DVD mode]	Bit 0	Y delay (I n DVD mode)	000:-40ns	100:120ns
	Bit 1		001:0	101:160ns
	Bit 2		010:40ns	110:200ns
			011:80ns	111:240ns
	Bit 3	NTSC matrix	00:NTSC 1(93°)	10,11:FOR DVD
	Bit 4		01:NTSC 2(108°)	
	Bit 5	C-GAMMA	0: chroma γ correction off	1: on
	Bit 6	Color killer off	0: normal	1: color killer always off (always have color)
Bit 7	P/N ID	0:P/N color killing sensitivity 1.2/1.5mVp-p	1:6.6/6.4 mV p-p	
NSHP	When NOISE REDUCE ON, sharpness register's content=OSD sharpness value-NSHP value			

USA CHANNEL FREQUENCY TABLE (181 CH)

P IF=45.75 MHz

C IF=42.17MHz

S IF=41.25MHz

UNIT: MHz

BAND	CHANNEL	P CARRIER	S CARRIER	LOCAL
VHF Low	2	55.25	59.75	101
	3	61.25	65.75	107
	4	67.25	71.75	113
	5	77.25	81.75	123
	6	83.25	87.75	129
	A-6	85.25	89.75	131
	A-5	91.25	95.75	137
	A-4	97.25	101.75	143
	A-3	103.25	107.75	149
	A-2	109.25	113.75	155
	A-1	115.25	119.75	161
	A	121.25	125.75	167
	B	127.25	131.75	173
	C	133.25	137.75	179
VHF High	D	139.25	143.75	185
	E	145.25	149.75	191
	F	151.25	155.75	197
	G	157.25	161.75	203
	H	163.25	167.75	209
	I	169.25	173.75	215
	7	175.25	179.75	221
	8	181.25	185.75	227
	9	187.25	191.75	233
	10	193.25	197.75	239
	11	199.25	203.75	245
	12	205.25	209.75	251
	13	211.25	215.75	257
	J	217.25	221.75	263
	K	223.25	227.75	269
	L	229.25	233.75	275
	M	235.25	239.75	281
	N	241.25	245.75	287
	O	247.25	251.75	293
	P	253.25	257.75	299
	Q	259.25	263.75	305
	R	265.25	269.75	311
	S	271.25	275.75	317
	T	277.25	281.75	323
	U	283.25	287.75	329
	V	289.25	293.75	335
	W	295.25	299.75	341
	W+1	301.25	305.75	347
	W+2	307.25	311.75	353
	W+3	313.25	317.75	359
	W+4	319.25	323.75	365
	W+5	325.25	329.75	371
	W+6	331.25	335.75	377
	W+7	337.25	341.75	383
W+8	343.25	347.75	389	
W+9	349.25	353.75	395	
W+10	355.25	359.75	401	

BAND	CHANNEL	P CARRIER	S CARRIER	LOCAL
UHF	W+11	361.25	365.75	407
	W+12	367.25	371.75	413
	W+13	373.25	377.75	419
	W+14	379.25	383.75	425
	W+15	385.25	389.75	431
	W+16	391.25	395.75	437
	W+17	397.25	401.75	443
	W+18	403.25	407.75	449
	W+19	409.25	413.75	455
	W+20	415.25	419.75	461
	W+21	421.25	425.75	467
	W+22	427.25	431.75	473
	W+23	433.25	437.75	479
	W+24	439.25	443.75	485
	W+25	445.25	449.75	491
	W+26	451.25	455.75	497
	W+27	457.25	461.75	503
	W+28	463.25	467.75	509
	W+29	469.25	473.75	515
	14	471.25	475.75	517
	15	477.25	481.75	523
	16	483.25	487.75	529
	17	489.25	493.75	535
	18	495.25	499.75	541
	19	501.25	505.75	547
	20	507.25	511.75	553
	21	513.25	517.75	559
	22	519.25	523.75	565
	23	525.25	529.75	571
	24	531.25	535.75	577
	25	537.25	541.75	583
	26	543.25	547.75	589
	27	549.25	553.75	595
	28	555.25	559.75	601
	29	561.25	565.75	607
	30	567.25	571.75	613
	31	573.25	577.75	619
	32	579.25	583.75	625
	33	585.25	589.75	631
	34	591.25	595.75	637
	35	597.25	601.75	643
	36	603.25	607.75	649
	37	609.25	613.75	655
	38	615.25	619.75	661
	39	621.25	625.75	667
40	627.25	631.75	673	
41	633.25	637.75	679	
42	639.25	643.75	685	
43	645.25	649.75	691	
44	651.25	655.75	697	
45	657.25	661.75	703	

USA CHANNEL FREQUENCY TABLE (181 CH)

P IF=45.75 MHz

C IF=42.17MHz

S IF=41.25MHz

UNIT: MHz

BAND	CHANNEL	P CARRIER	S CARRIER	LOCAL
UHF	46	663.25	667.75	709
	47	669.25	673.75	715
	48	675.25	679.75	721
	49	681.25	685.75	727
	50	687.25	691.75	733
	51	693.25	697.75	739
	52	699.25	703.75	745
	53	705.25	709.75	751
	54	711.25	715.75	757
	55	717.25	721.75	763
	56	723.25	727.75	769
	57	729.25	733.75	775
	58	735.25	739.75	781
	59	741.25	745.75	787
	60	747.25	751.75	793
	61	753.25	757.75	799
	62	759.25	763.75	805
	63	765.25	769.75	811
	64	771.25	775.75	817
	65	777.25	781.75	823
	66	783.25	787.75	829
	67	789.25	793.75	835
	68	795.25	799.75	841
	69	801.25	805.75	847

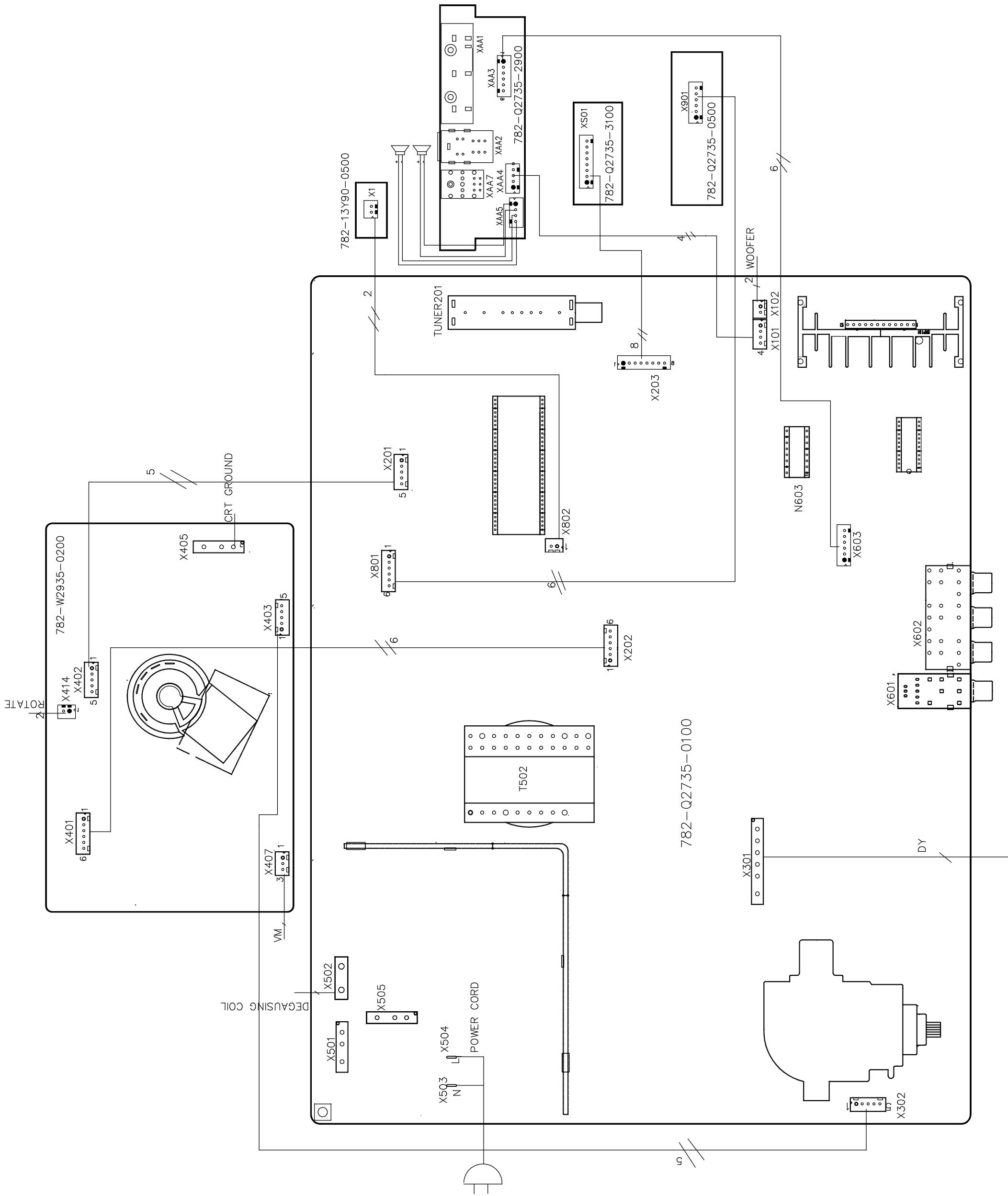

BLOCK DIAGRAM

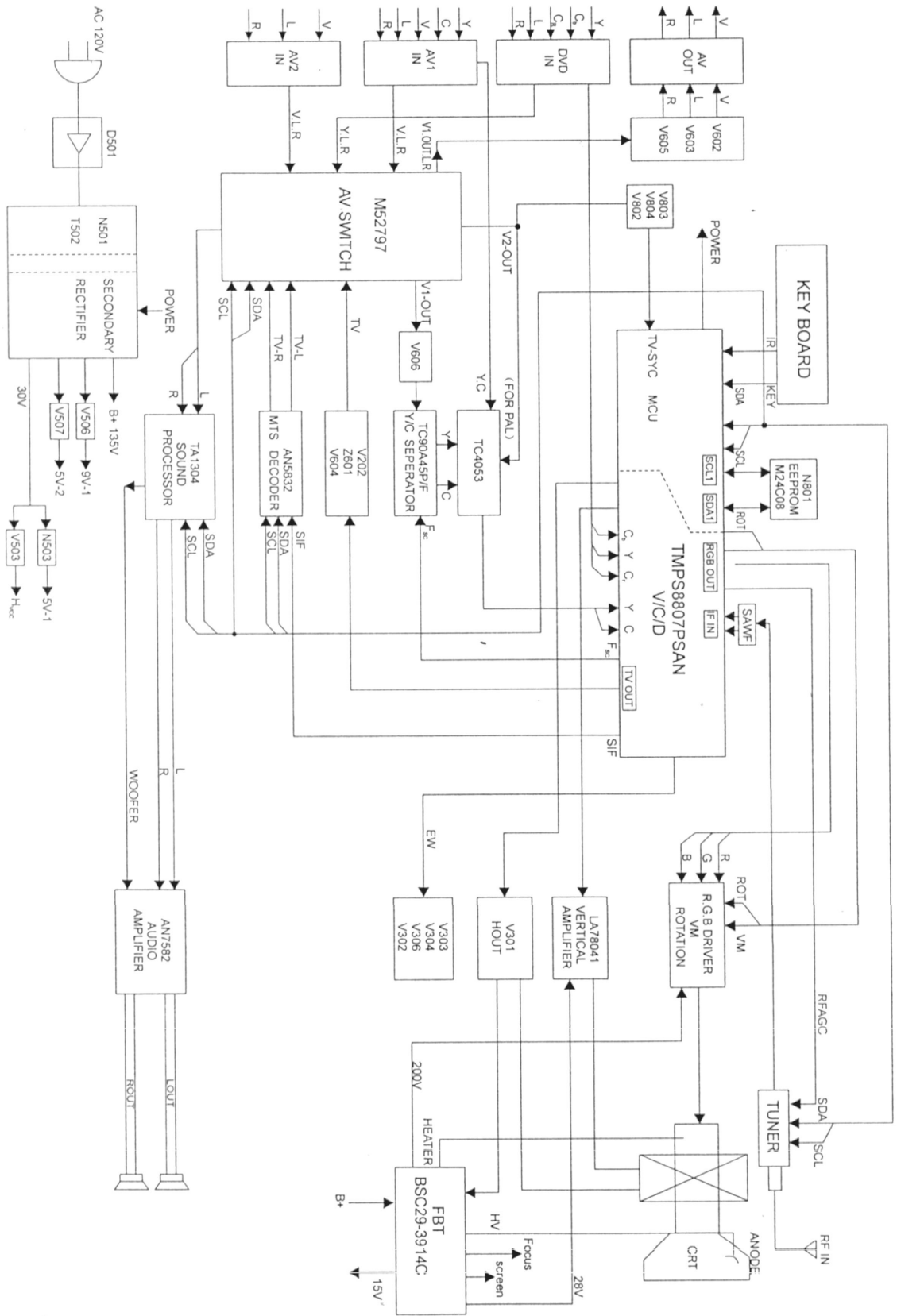

IC BLOCK DIAGRAM

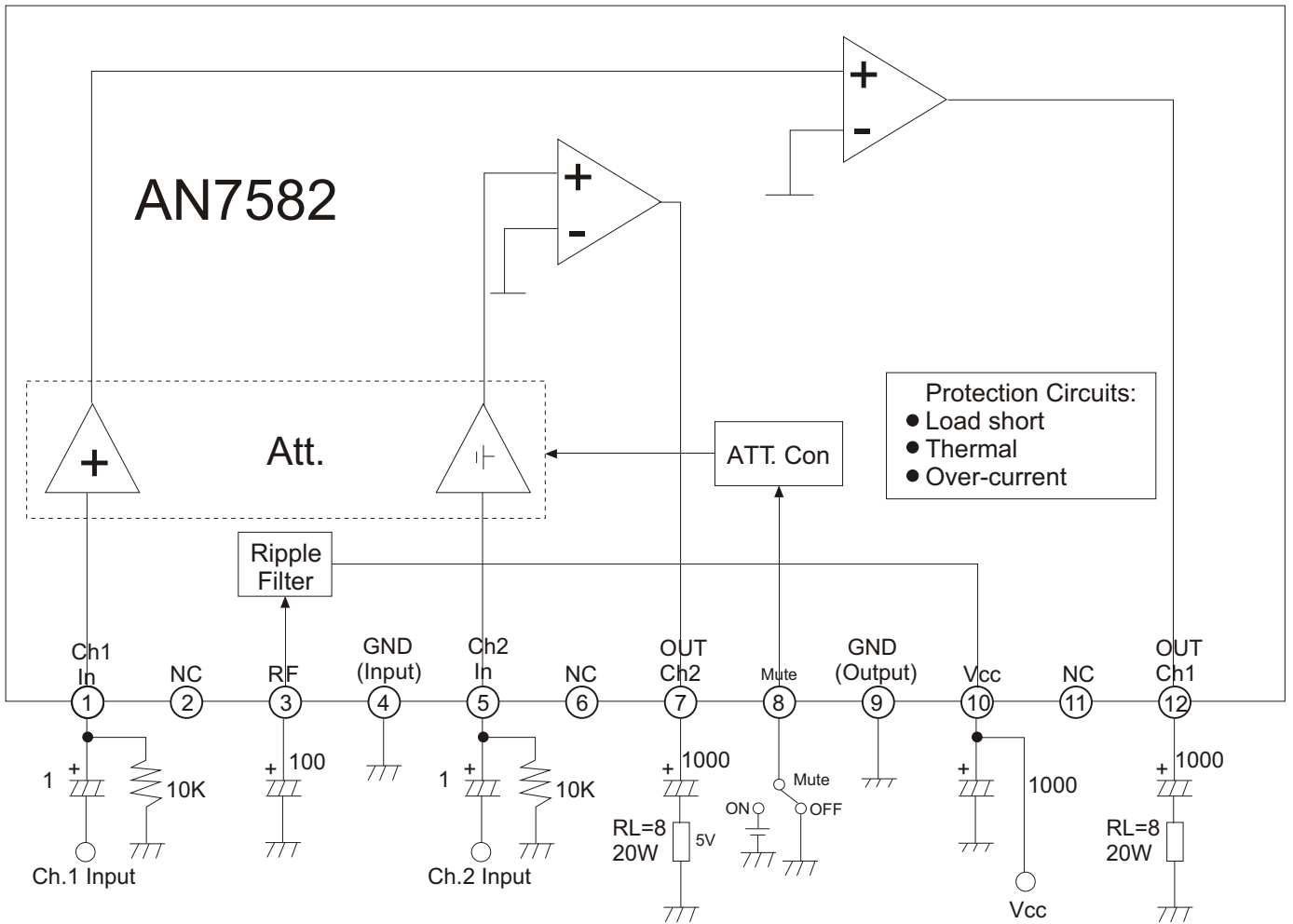

NOTE: For MUTE "OFF", connect MUTE to 0V.

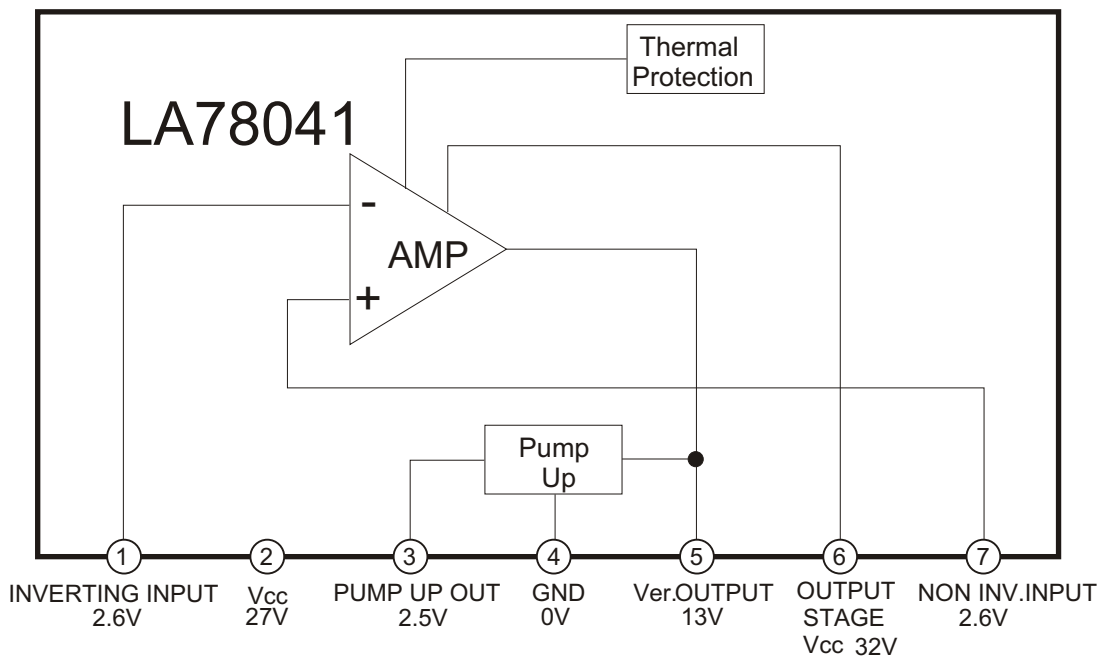

TMPA8807

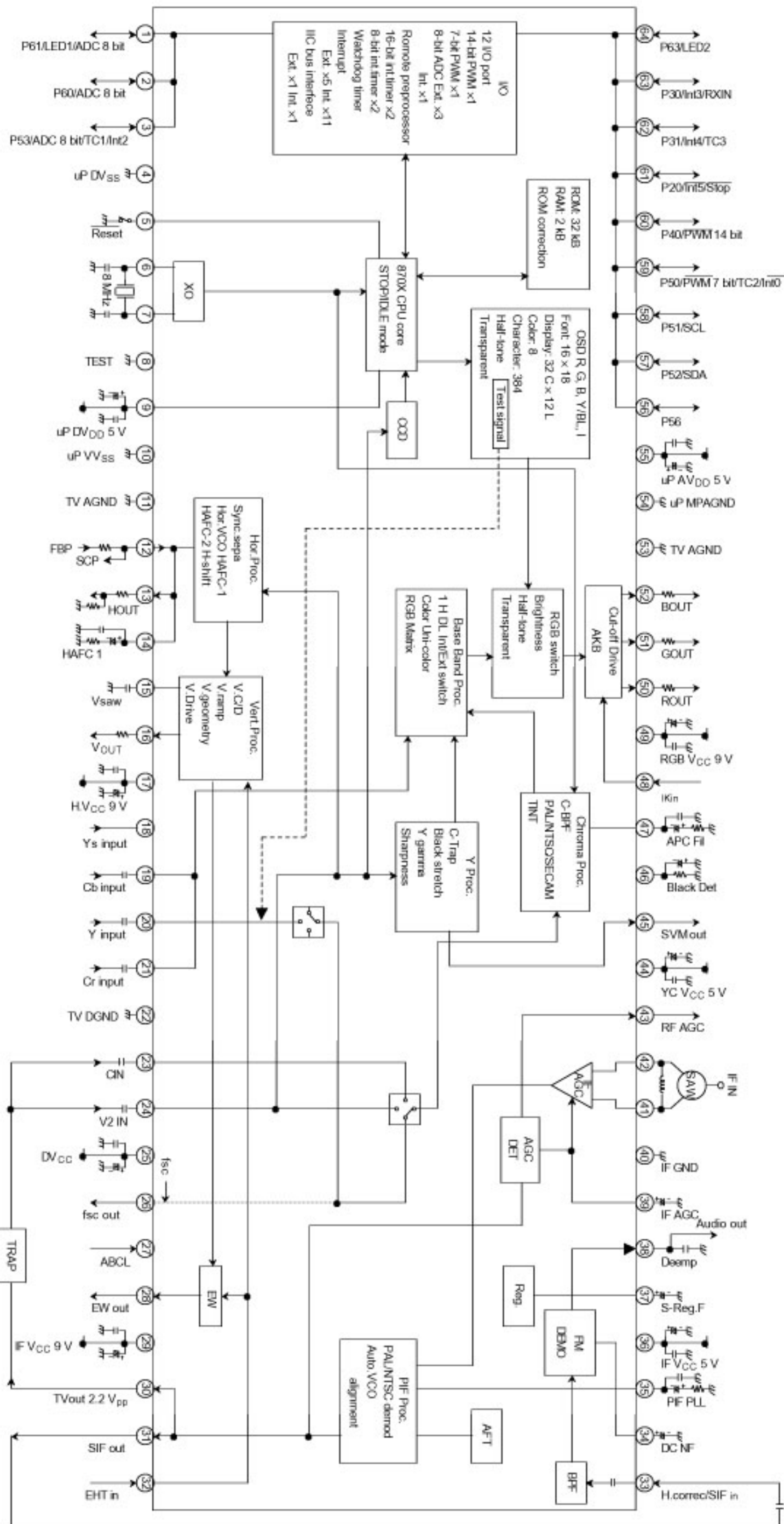

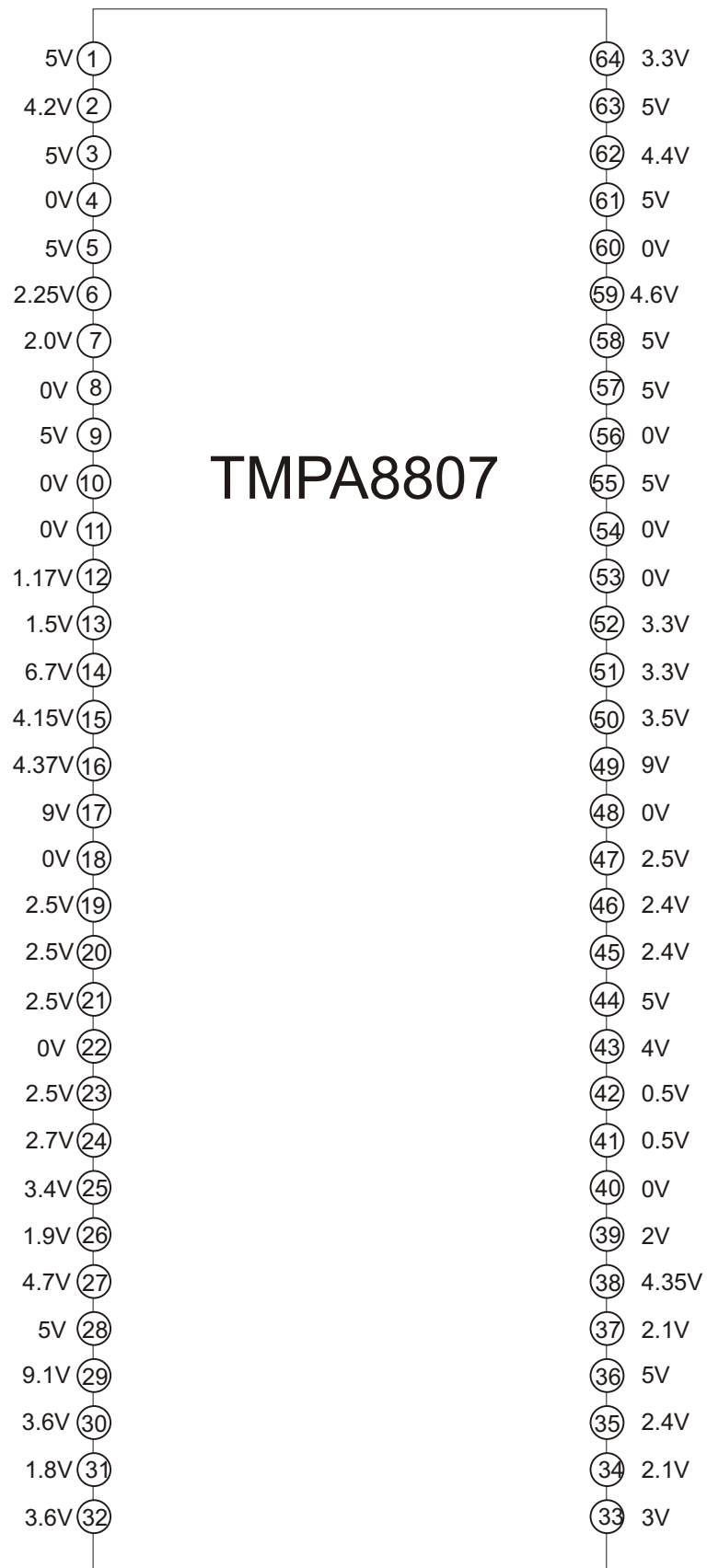

TA1304F/N

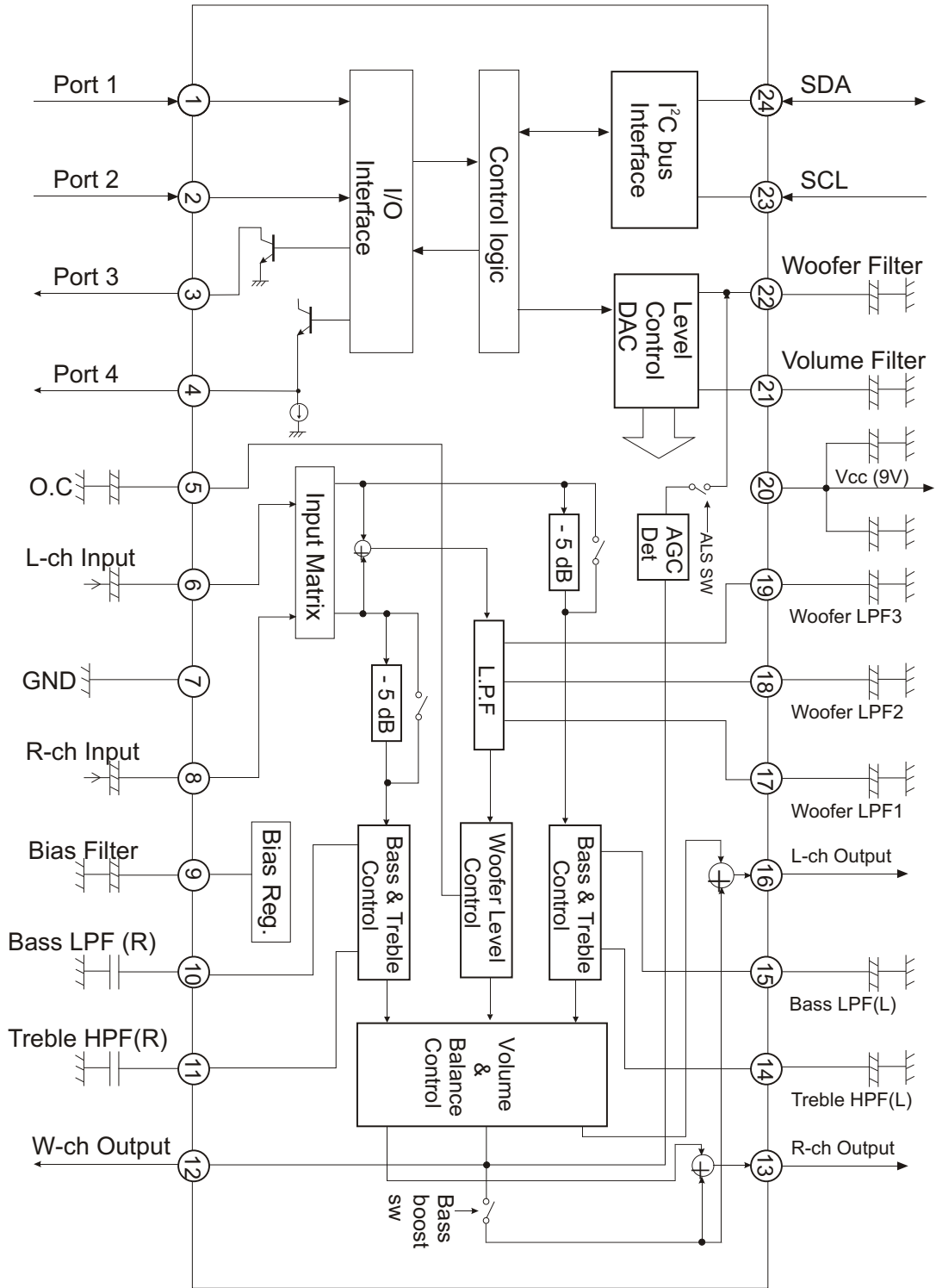

STR-G9656

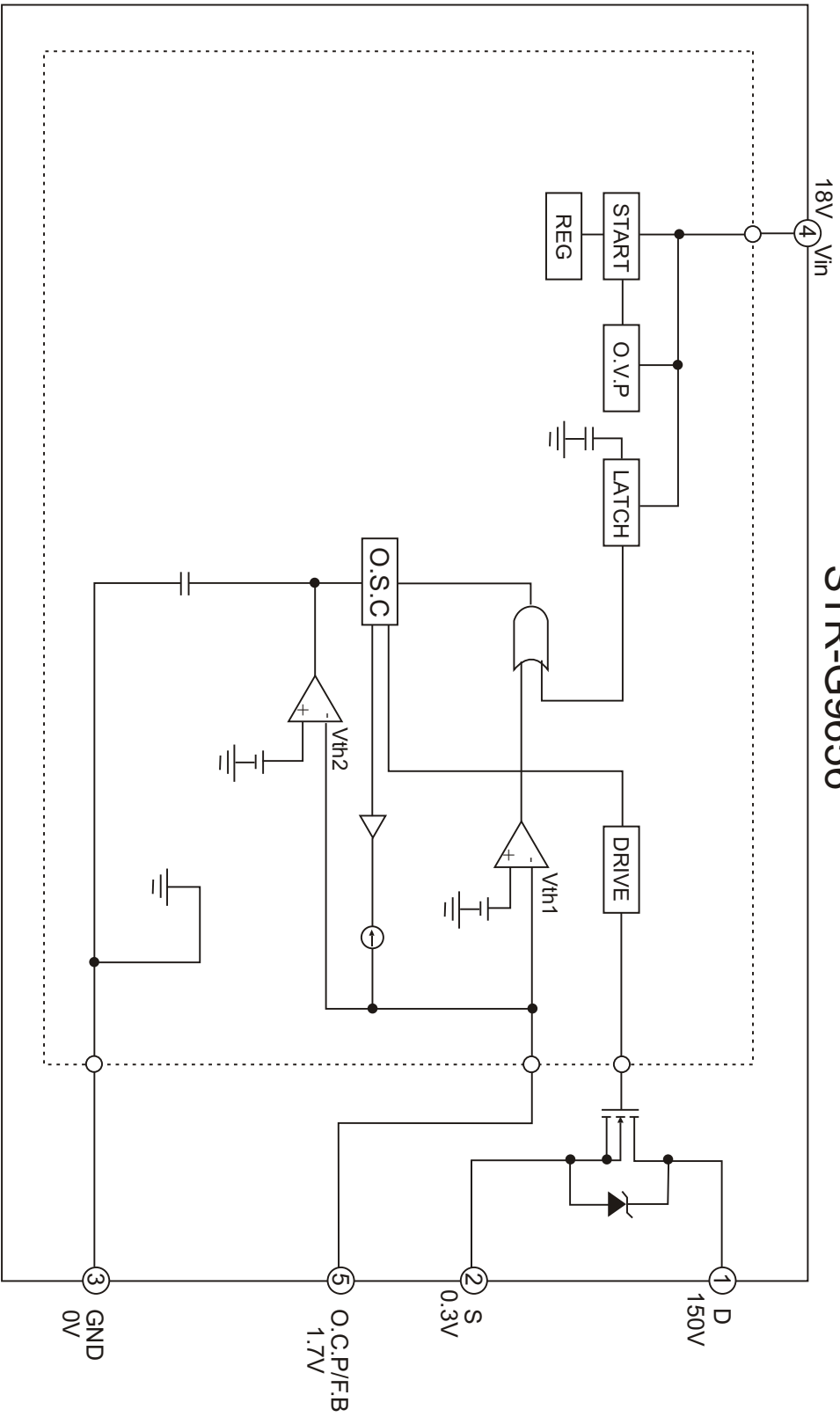

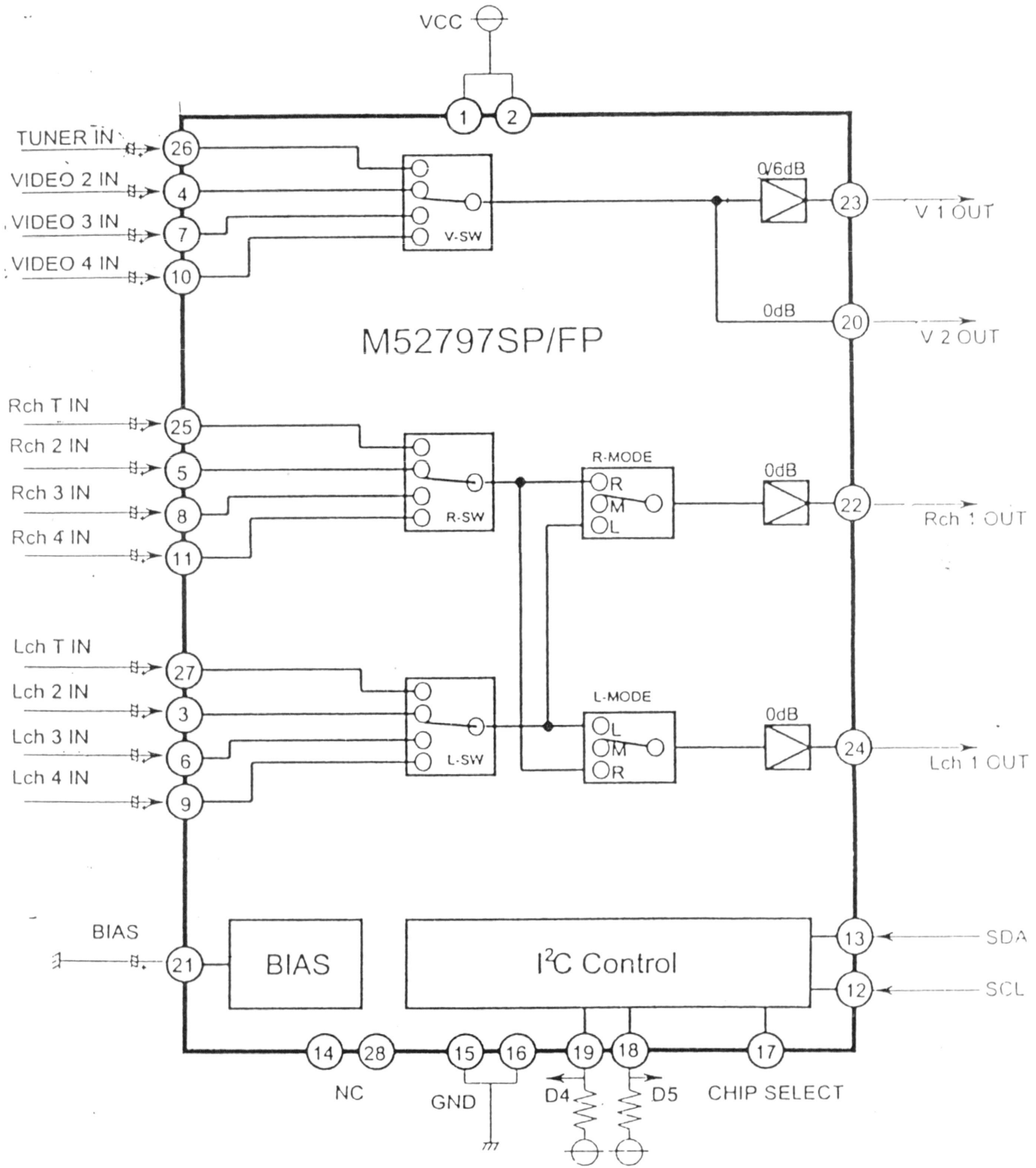

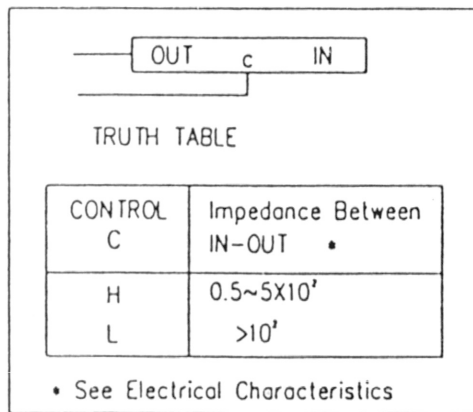
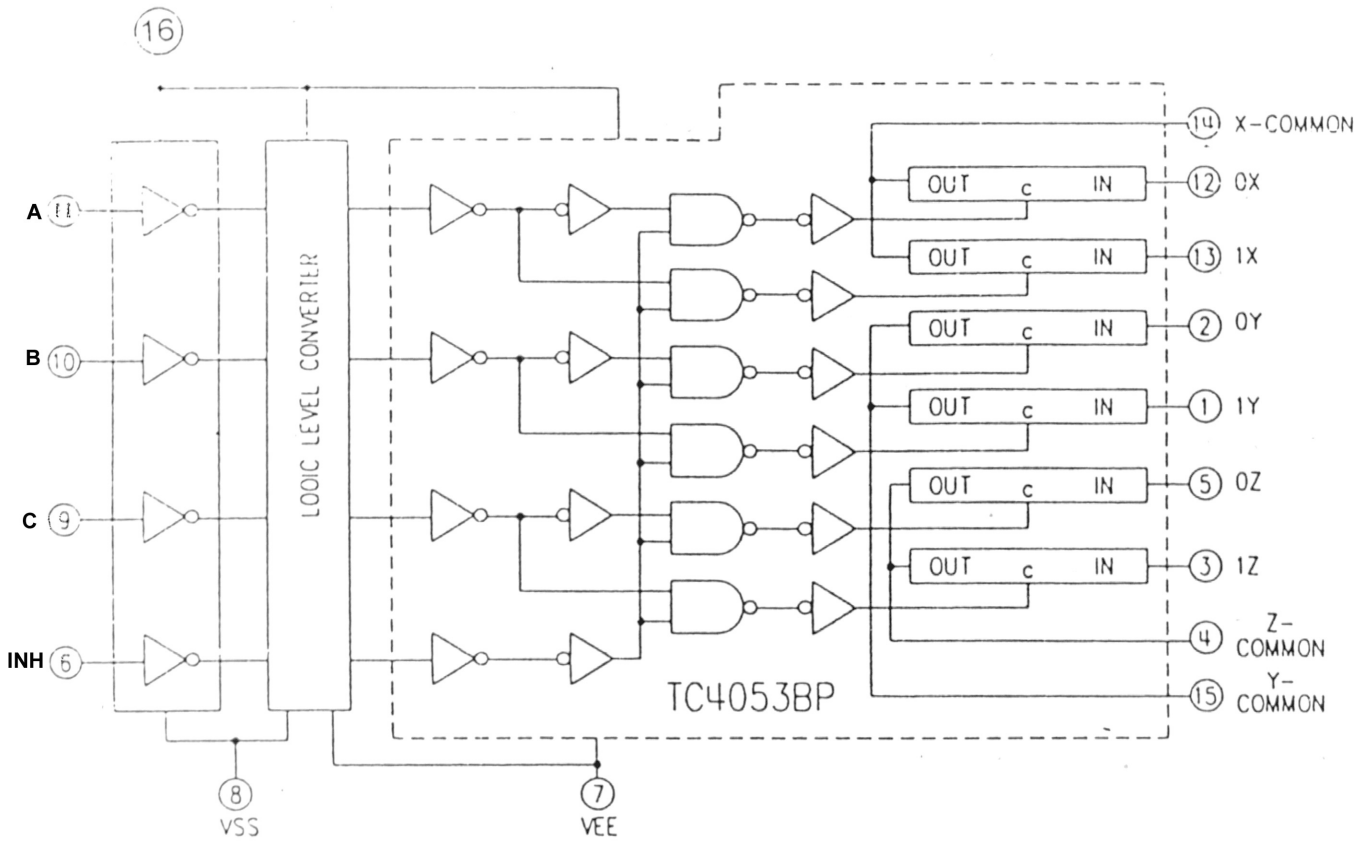

TC90A45P/F

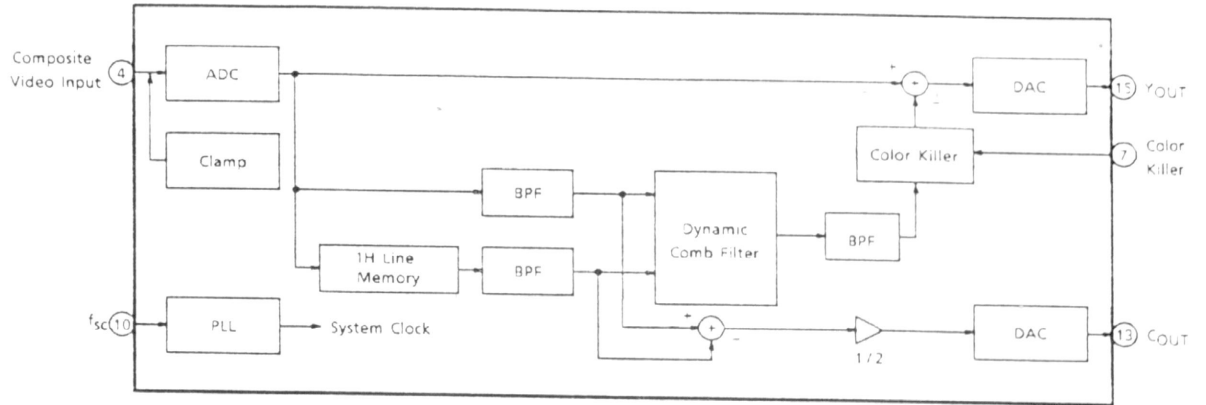

TERMINAL CONNECTION DIAGRAM

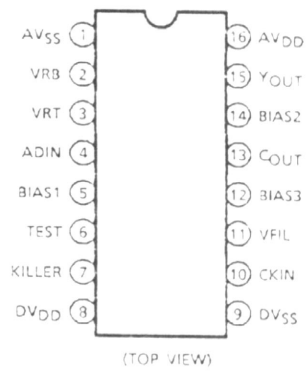

COMPONENT AND BOTTOM VIEW
COMPONENT VIEW MAIN BOARD

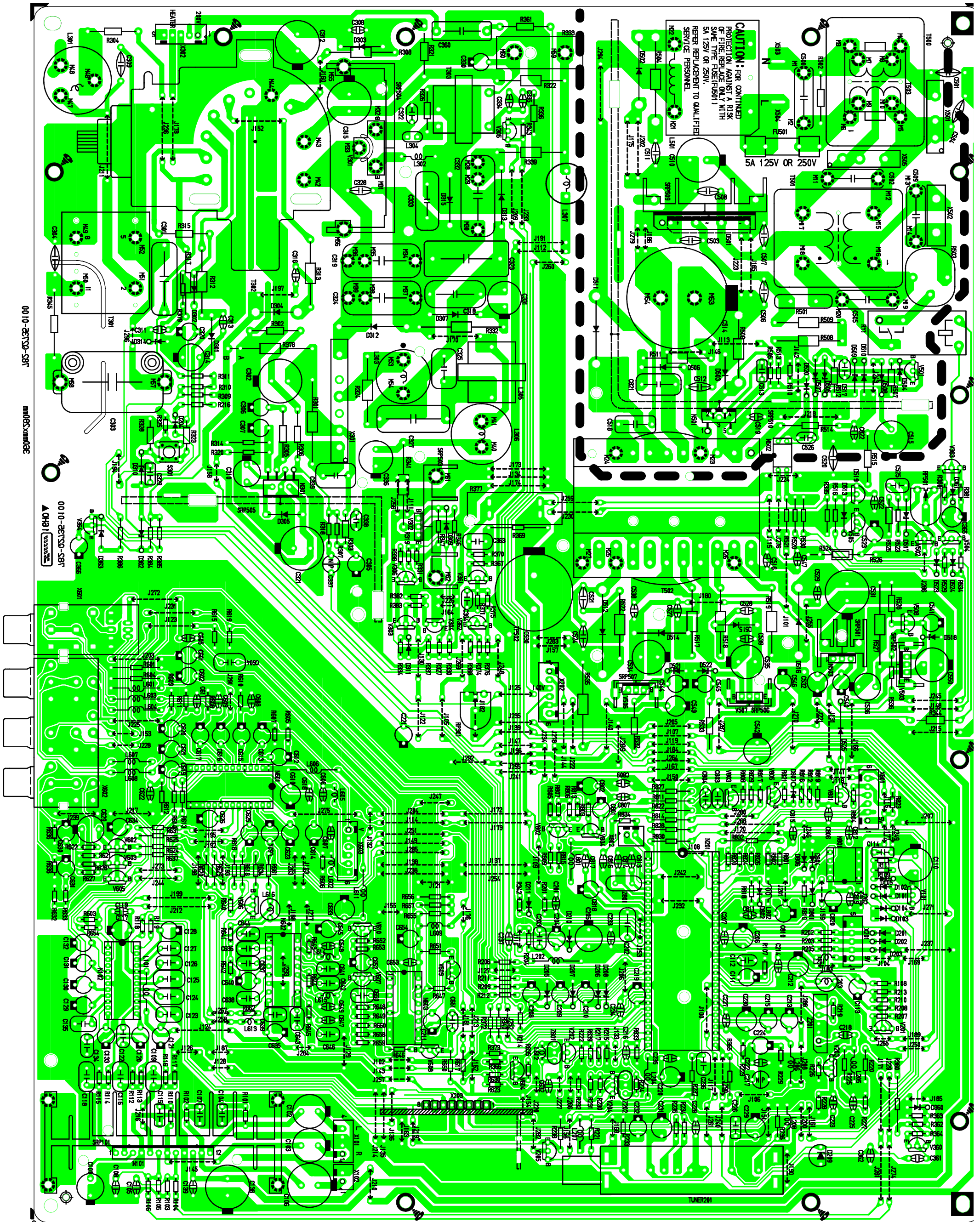

BOTTOM VIEW MAIN BOARD

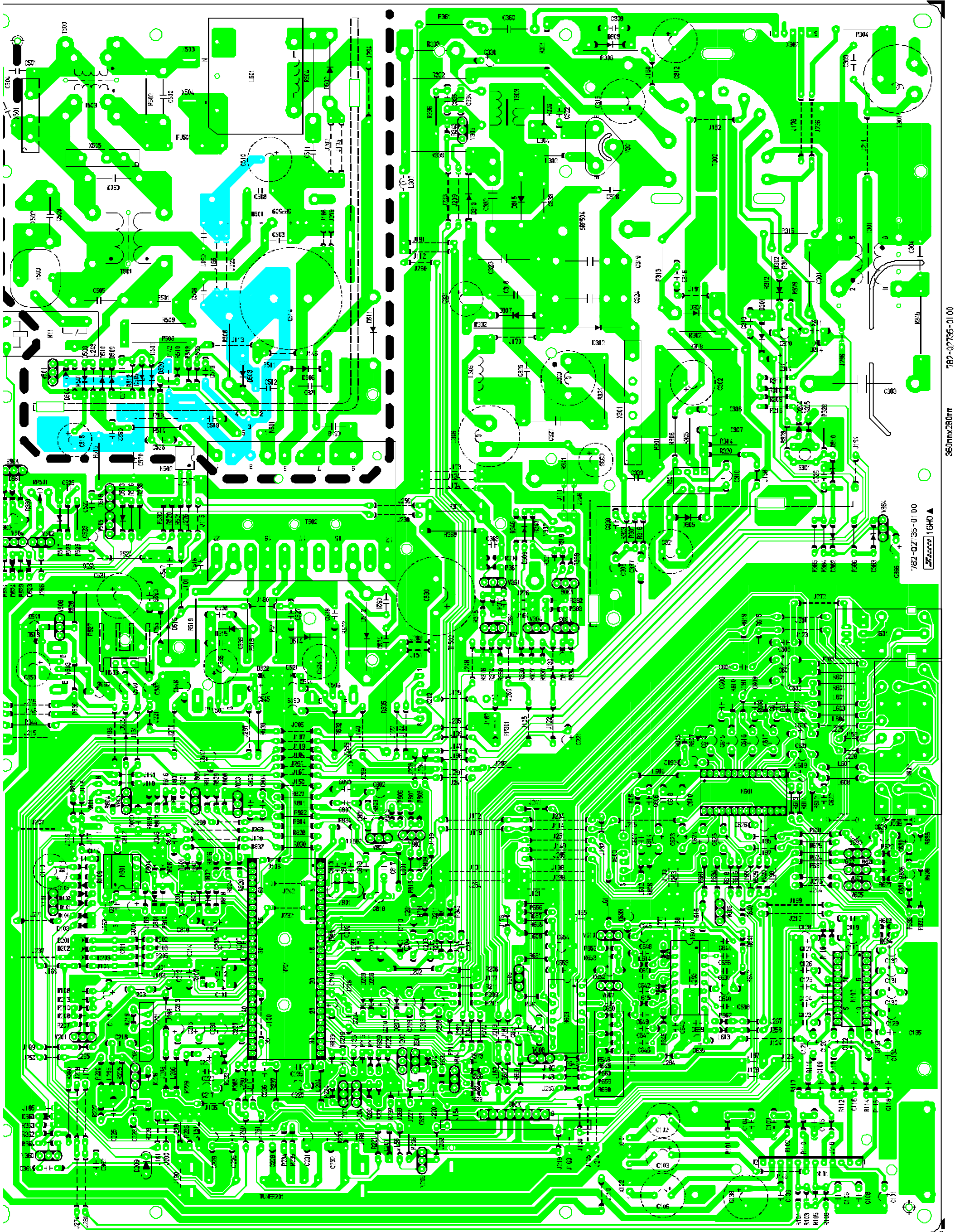

COMPONENT VIEW OF CRT BOARD

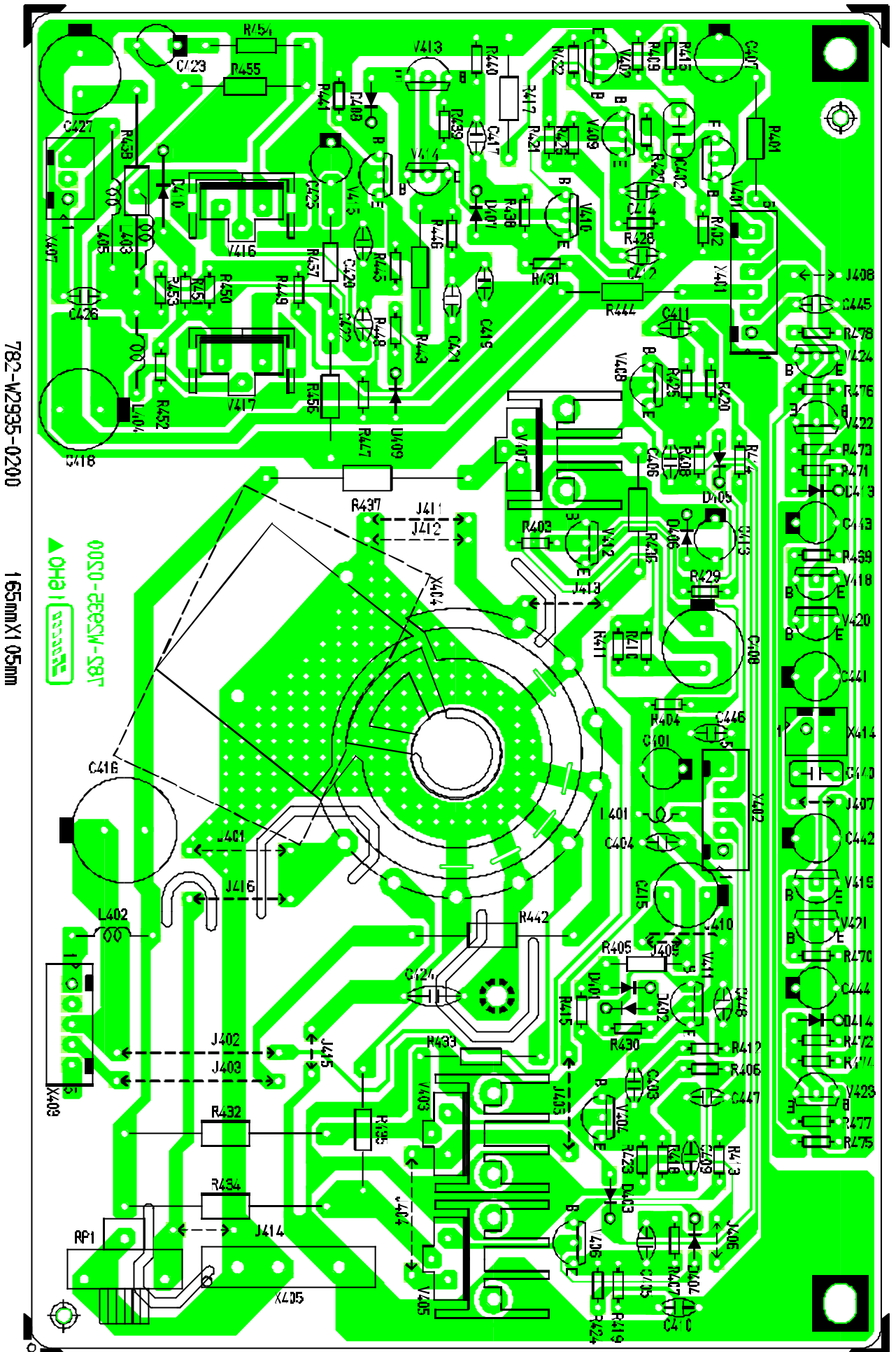

BOTTOM VIEW OF CRT BOARD

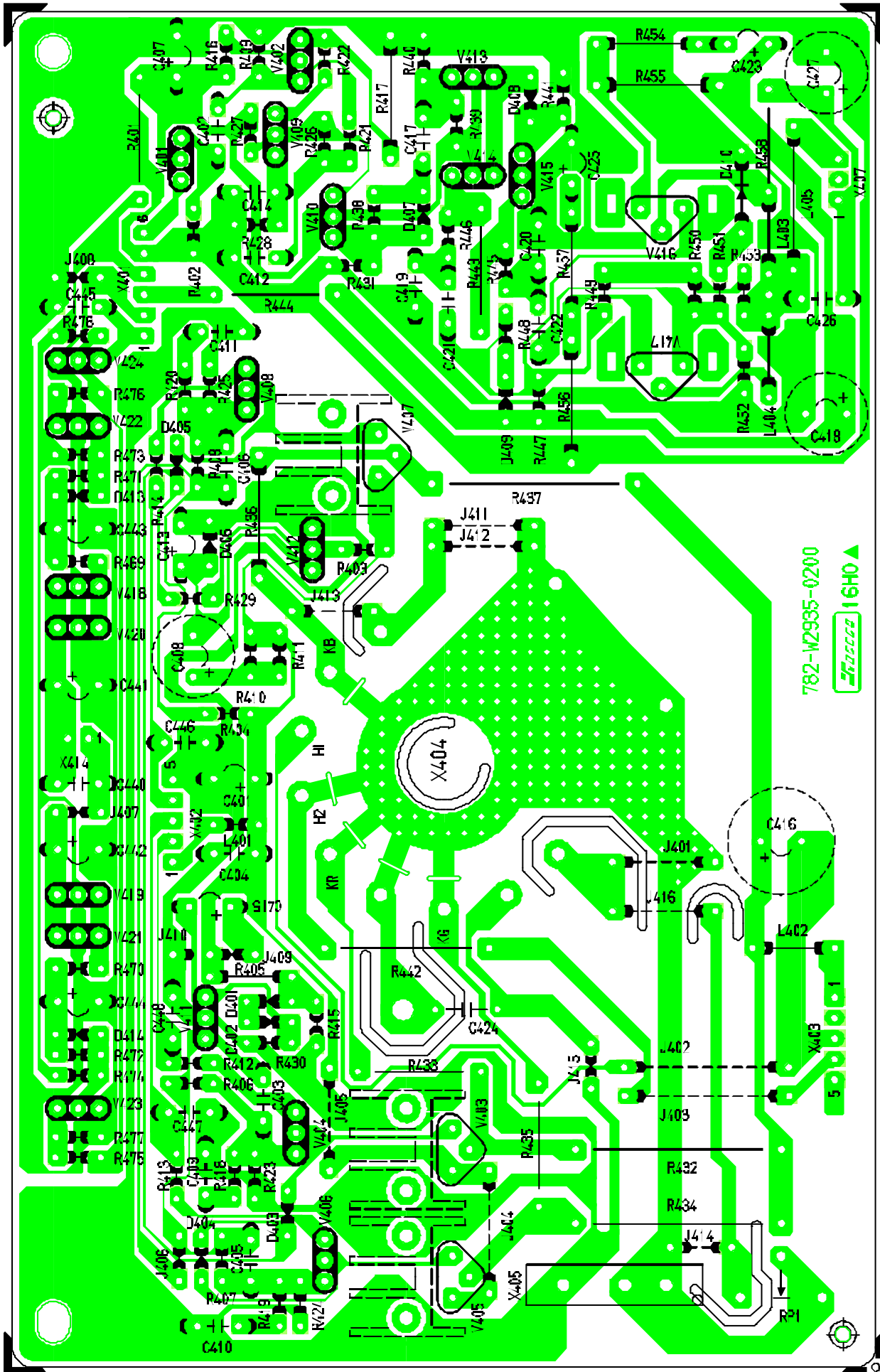

782-W2935-0200

2002-3-13

782-W2935-0200
FRONTIER 16H0

CAUTION: All the parts in the schematic diagram marked with red frame and the signs of \triangle are extremely important a safety. In case of replacement of any part of the components. Be sure to consult the service manual carefully.

1. The schematic diagram is characteristic. The various values in the electric circuits are basic data, which are changeable according to the various basic circuits.
2. Testing waves are obtained by inputting the standard color bar of the signed.
3. Resistance unit is in Ohm, namely:
 $K=1000$ $M=1000K$
 Capacitance unit is in μF .
 $P=\mu\mu F (\mu=10^{-6})$
4. Unless otherwise noted inside, all resistors are 1/6W, the withstand voltage of all capacitor are 50V.
5. Inductance unit is in μH .
6. The mark \rightleftharpoons in the diagram means Ferrite ring.
7. The symbols of various types of resistors and capacitors are listed as follows:

Carbon Film	
Metal Film	
Potentiometer	
1/2W	
1W	
2W	
3W	
Ceramic	
AC Ceramic	
Ployester	
Ploypropylene	
Metal Polyester	
Aluminium	
Tantalum	

782-Q2735-0100
MAIN BOARD
2002.03.20

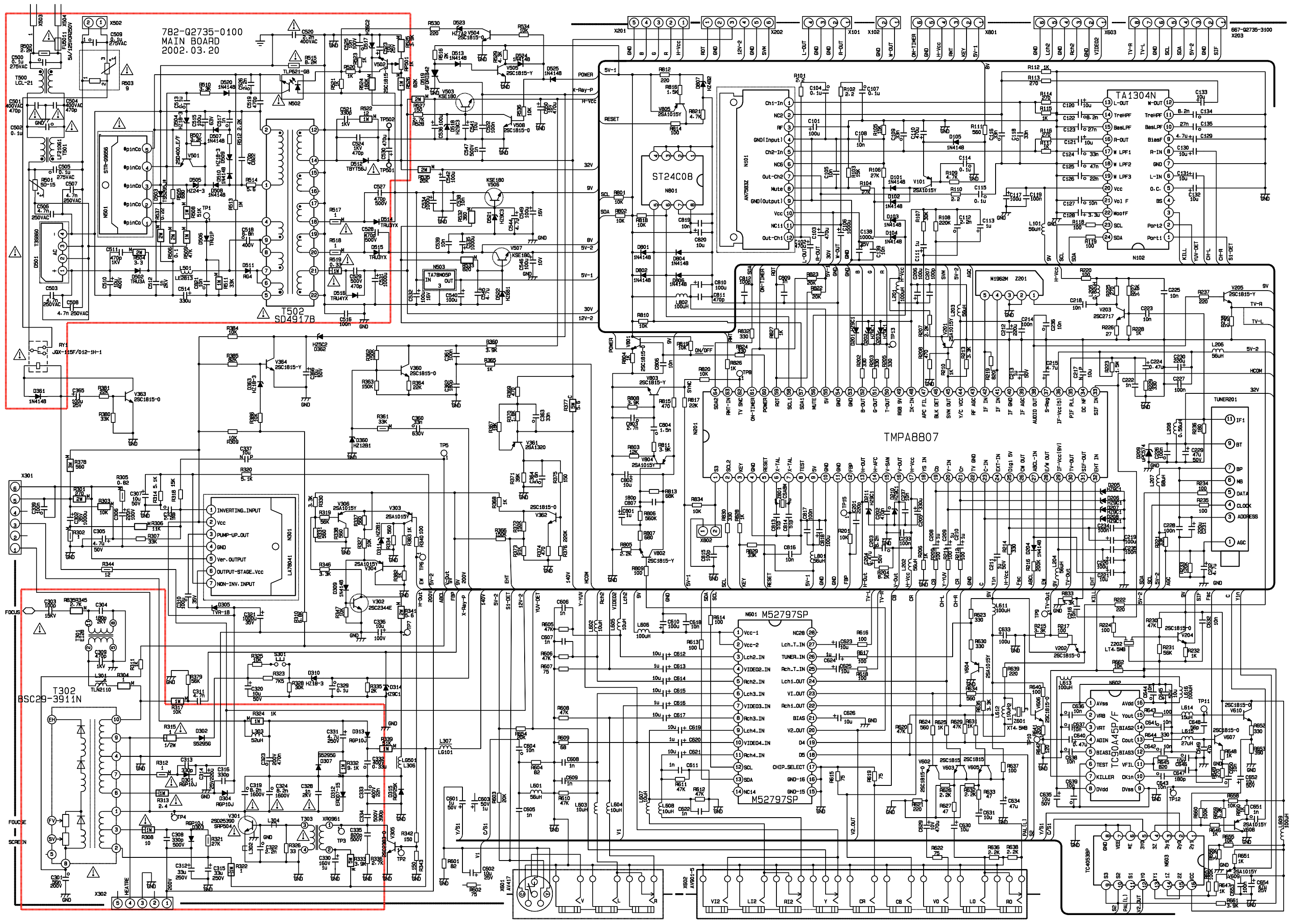

782-Q2735-0100
MAIN BOARD
2002.03.20

782-Q2735-0100
MAIN BOARD
2002.03.20

782-Q2735-0100
MAIN BOARD
2002.03.20

782-Q2735-0100
MAIN BOARD
2002.03.20

782-Q2735-0100
MAIN BOARD
2002.03.20

782-Q2735-0100
MAIN BOARD
2002.03.20

782-Q2735-0100
MAIN BOARD
2002.03.20

782-Q2735-0100
MAIN BOARD
2002.03.20

782-Q2735-0100
MAIN BOARD
2002.03.20

782-Q2735-0100
MAIN BOARD
2002.03.20

782-Q2735-0100
MAIN BOARD
2002.03.20

782-Q2735-0100
MAIN BOARD
2002.03.20

782-Q2735-0100
MAIN BOARD
2002.03.20

782-Q2735-0100
MAIN BOARD
2002.03.20

782-Q2735-0100
MAIN BOARD
2002.03.20

782-Q2735-0100
MAIN BOARD
2002.03.20

782-Q2735-0100
MAIN BOARD
2002.03.20

782-Q2735-0100
MAIN BOARD
2002.03.20

782-Q2735-0100
MAIN BOARD
2002.03.20

782-Q2735-0100
MAIN BOARD
2002.03.20

782-Q2735-0100
MAIN BOARD
2002.03.20

782-Q2735-0100
MAIN BOARD
2002.03.20

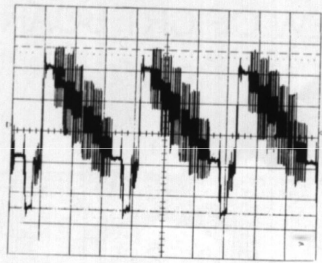

(1) 1V_{p,p}

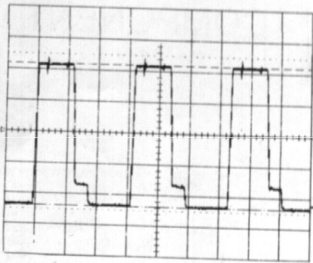

(2) 4.5V_{p,p}

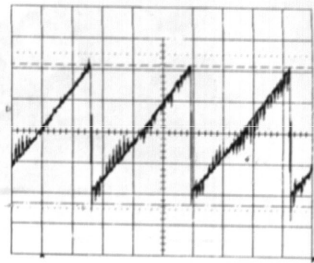

(3) 2.2V_{p,p}

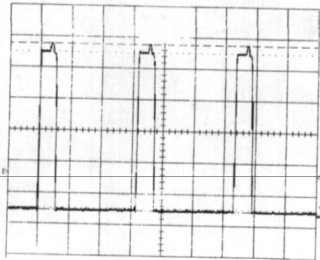

(4) 5.3V_{p,p}

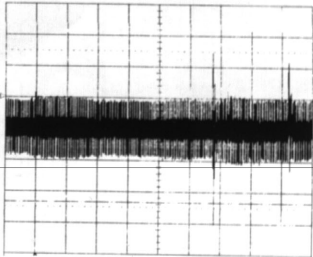

(5) 200mV_{p,p}

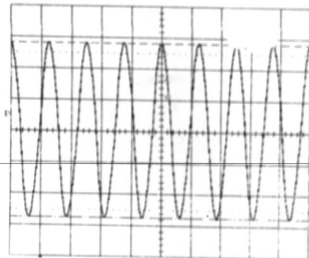

(6) 5.5V_{p,p}

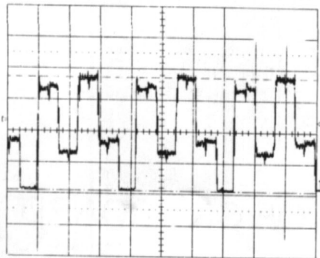

(7) 3.6V_{p,p}

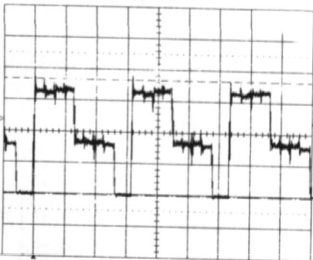

(8) 3.7V_{p,p}



(9) 3.7V_{p,p}

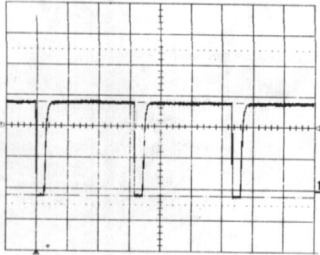

(10) 6V_{p,p}

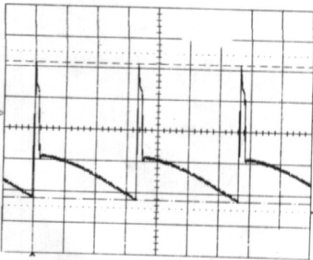

(11) 44V_{p,p}



(12) 862V_{p,p}

(14) 1.6V_{p,p}(L)

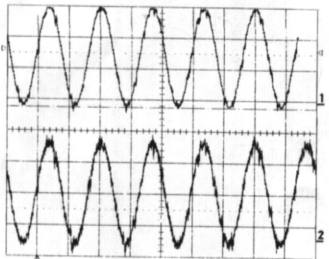

(13) 1.86V_{p,p}(R)

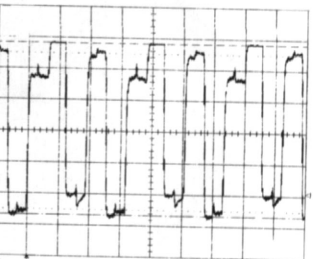

(15) 110V_{p,p}



(16) 101V_{p,p}

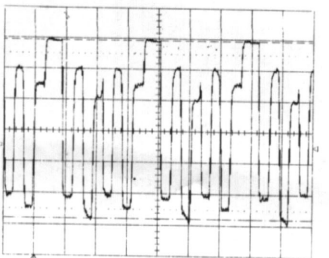

(17) 114V_{p,p}



(18) 444V_{p,p}

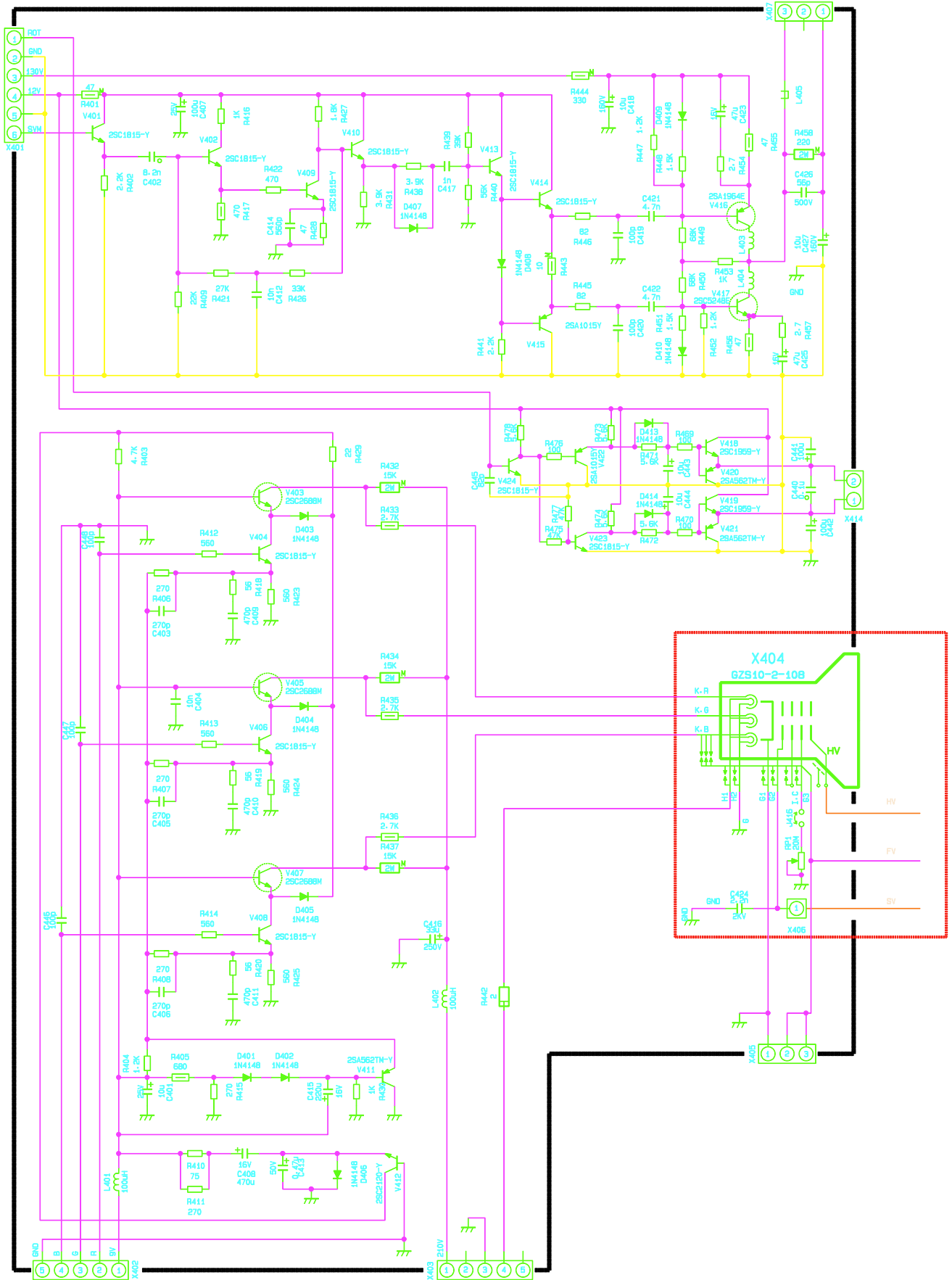

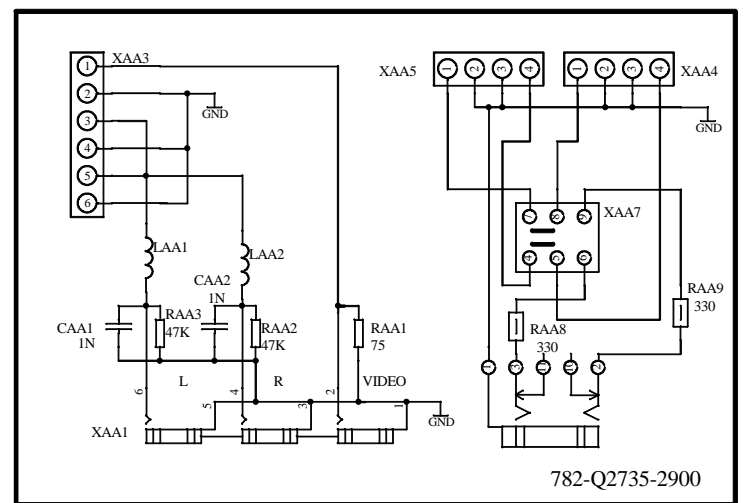
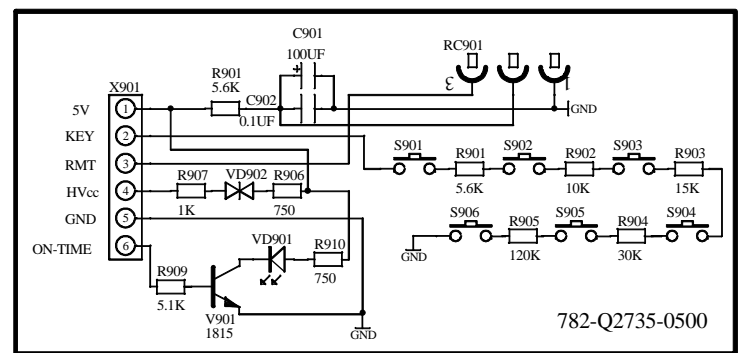
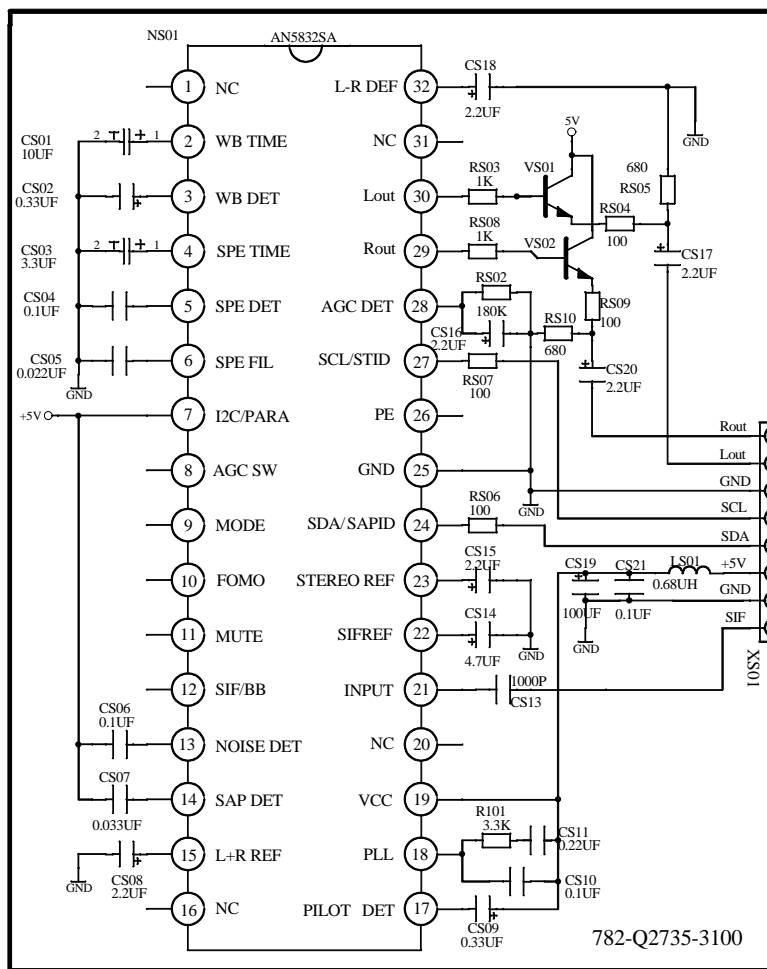
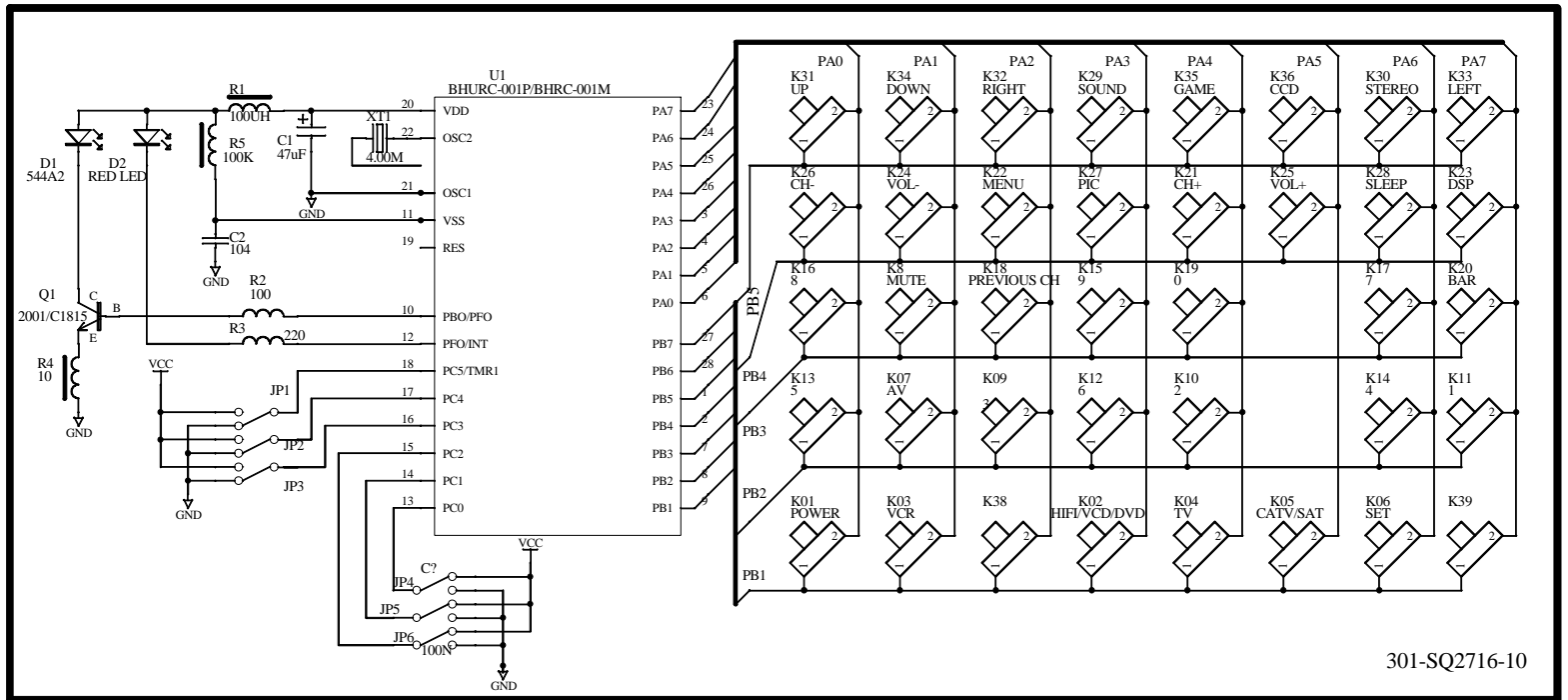

WARNING: BEFORE SERVICING THIS CHASSIS, READ THE “X-RAY RADIATION PERCAUTION”, “SAFETY PRECAUTION” AND “PRODUCT SAFETY NOTICE” ON PAGE 1&2 OF THIS MANUAL.

CAUTION: 1. The shaded areas makes in the schematic diagram and the parts list designate components which have special characteristics important for safety and should be replaced only with type identical to those in the original circuit or specified in the parts list. Before replacing any of these components, read carefully the PRODUCT SAFETY NOTICE on page 2.

2. Do not degrade the safety of the receiver through improper servicing.

ELECTRICAL PARTS LIST

MAIN BOARD

SYMBOL	PART NO.	DESCRIPTION
	782-Q2735-010	MAIN PCB
CRYSTAL		
Z801	329-58001-00	8MHZ
DIODE		
D304	340-00014-00	RGP10J
D315	340-00060-00	RGP25K
D512	340-00257-00	BYT56J
D514	340-00283-00	TRU3YX
D515	340-00283-00	TRU3YX
D516	340-00284-00	TRU4YX
D312	340-00297-00	ERD07-15
D309	340-00001-003	1N4148
D103	340-00001-003	1N4148
D104	340-00001-003	1N4148
D806	340-00001-003	1N4148
D804	340-00001-003	1N4148
D802	340-00001-003	1N4148
D801	340-00001-003	1N4148
D204	340-00001-003	1N4148
D524	340-00001-003	1N4148
D525	340-00001-003	1N4148
D510	340-00001-003	1N4148
D508	340-00001-003	1N4148
D507	340-00001-003	1N4148
D101	340-00001-003	1N4148
D102	340-00001-003	1N4148

SYMBOL	PART NO.	DESCRIPTION
D105	340-00001-003	1N4148
D361	340-00001-003	1N4148
D513	340-00001-003	1N4148
D520	340-00001-003	1N4148
D503	340-00005-003	S5295J
D307	340-00010-003	S5295G
D302	340-00010-003	S5295G
D313	340-00014-003	RGP10J
D301	340-00014-003	RGP10J
D303	340-00014-003	RGP10J
D305	340-00086-003	TVR-1B
RECTIFIER		
D506	340-80010-00	RUIP
D501	340-80019-00	T3SB60
REGULATED DIODE		
D311	340-50270-003	HZ3A2
D807	340-50390-003	HZ4B2
D522	340-50560-003	HZ6B1
D517	340-50610-003	HZ6C2
D523	340-50650-003	HZ7A2
D203	340-50820-003	HZ9A3
D202	340-50820-003	HZ9A3
D201	340-50820-003	HZ9A3
D207	340-50820-003	HZ9A3
D208	340-50820-003	HZ9A3
D211	340-50820-003	HZ9A3
D205	340-50820-003	HZ9A3
D206	340-50820-003	HZ9A3
D314	340-50910-003	HZ9C1
D210	340-50910-003	HZ9C1
D518	340-50950-003	HZ9C3
D521	340-50950-003	HZ9C3
D360	340-51260-003	HZ12B1
D310	340-51850-003	HZ18-3
D509	340-51850-003	HZ18-3
D504	340-51850-003	HZ18-3
D363	340-51850-003	HZ18-3
D505	340-52490-003	HZ24-3
TRANSISTOR		
V503	343-01800-00	KSE180 TO-126
V507	343-01800-00	KSE180 TO-126
V506	343-01800-00	KSE180 TO-126
V361	343-13200-00	2SA1320

SYMBOL	PART NO.	DESCRIPTION
V305	343-23830-60	2SC2383-0
V301	343-25390-00	2SD2539
V203	343-27170-00	2SC2717
V302	343-38520-00	2SC3852
D519	343-00420-404	SFORIB42
V501	343-04000-304	2SD400 E/F
V608	343-10150-104	2SA1015Y Pr2.5
V609	343-10150-104	2SA1015Y Pr2.5
V805	343-10150-104	2SA1015Y Pr2.5
V804	343-10150-104	2SA1015Y Pr2.5
V304	343-10150-104	2SA1015Y Pr2.5
V303	343-10150-104	2SA1015Y Pr2.5
V306	343-10150-104	2SA1015Y Pr2.5
V604	343-10150-104	2SA1015Y Pr2.5
V201	343-10150-104	2SA1015Y Pr2.5
V101	343-10150-104	2SA1015Y Pr2.5
V802	343-18150-114	2SC1815-Y
V803	343-18150-114	2SC1815-Y
V502	343-18150-114	2SC1815-Y
V205	343-18150-114	2SC1815-Y
V363	343-18150-114	2SC1815-Y
V360	343-18150-114	2SC1815-Y
V364	343-18150-114	2SC1815-Y
V505	343-18150-114	2SC1815-Y
V801	343-18150-604	2SC 1815-0
V610	343-18150-604	2SC 1815-0
V204	343-18150-604	2SC 1815-0
V607	343-18150-604	2SC 1815-0
V606	343-18150-604	2SC 1815-0
V202	343-18150-604	2SC 1815-0
V602	343-18150-604	2SC 1815-0
V603	343-18150-604	2SC 1815-0
V605	343-18150-604	2SC 1815-0
V504	343-18150-604	2SC 1815-0
V508	343-18150-604	2SC 1815-0
V362	343-18150-604	2SC 1815-0
CERAMIC CAPACITOR		
C649	459-2047H-102	CC45-CH1H470JYR
C814	459-2051H-102	CC1-08-CH-63V-51pF-J
C813	459-2051H-102	CC1-08-CH-63V-51pF-J
C648	459-2056H-102	CC1-08-CH-63V-56pF-J
C815	459-2110H-102	CC45-CH1H101JYR
C812	459-2110H-102	CC45-CH1H101JYR
C647	459-2118H-102	CC45-CH1H181JYR

SYMBOL	PART NO.	DESCRIPTION
C807	459-2118H-102	CC45-CH1H181JYR
C362	459-2118H-102	CC45-CH1H181JYR
C519	459-2147H-902	CC1-12-SL-63V-471J
C525	459-2210K-002	CK45-B1H102KYR
C222	459-2210K-002	CK45-B1H102KYR
C608	459-2210K-002	CK45-B1H102KYR
C609	459-2210K-002	CK45-B1H102KYR
C611	459-2210K-002	CK45-B1H102KYR
C622	459-2210K-002	CK45-B1H102KYR
C605	459-2210K-002	CK45-B1H102KYR
C218	459-2310R-002	CK45-F1H103ZYR
C223	459-2310R-002	CK45-F1H103ZYR
C225	459-2310R-002	CK45-F1H103ZYR
C538	459-2310R-002	CK45-F1H103ZYR
C539	459-2310R-002	CK45-F1H103ZYR
C618	459-2310R-002	CK45-F1H103ZYR
C216	459-2310R-002	CK45-F1H103ZYR
C806	459-2310R-002	CK45-F1H103ZYR
C819	459-2310R-002	CK45-F1H103ZYR
C108	459-2310R-002	CK45-F1H103ZYR
C105	459-2310R-002	CK45-F1H103ZYR
C139	459-2310R-002	CK45-F1H103ZYR
C604	459-2310R-002	CK45-F1H103ZYR
C632	459-2310R-002	CK45-F1H103ZYR
C228	459-2410R-002	DD308-63F104Z50
C227	459-2410R-002	DD308-63F104Z50
C207	459-2410R-002	DD308-63F104Z50
C811	459-2410R-002	DD308-63F104Z50
C214	459-2410R-002	DD308-63F104Z50
C639	459-2410R-002	DD308-63F104Z50
C329	459-2410R-002	DD308-63F104Z50
C522	459-2410R-002	DD308-63F104Z50
C817	459-2410R-002	DD308-63F104Z50
C234	459-2410R-002	DD308-63F104Z50
C235	459-2410R-002	DD308-63F104Z50
C119	459-2410R-002	DD308-63F104Z50
C233	459-2410R-002	DD308-63F104Z50
C653	459-2410R-002	DD308-63F104Z50
C516	459-2410R-002	DD308-63F104Z50
C308	459-5133K-002	RQC05B331K-H46CA
C316	459-5133K-002	RQC05B331K-H46CA
C334	459-5139K-002	CK45-B2H391KYR
C529	459-5147K-002	RQC05B471K-H46CA
C528	459-5147K-002	RQC05B471K-H46CA

SYMBOL	PART NO.	DESCRIPTION
C527	459-5147K-002	RQC05B471K-H46CA
C822	459-5147K-002	RQC05B471K-H46CA
C335	459-5182K-002	DD06-999B812K500
C547	459-5210K-002	CK45-B2H102KYR
C127	459-2410R-002	DD308-63F104Z50
C501	459-B147M-20	ECK-DNS471MBX !
C504	459-B147M-20	ECK-DNS471MBX !
C520	459-B222M-20	ECK-DNS222MEX !
C507	459-B247R-00	DE0807F472ZAC250V !
C503	459-B247R-00	DE0807F472ZAC250V !
C508	459-B247R-00	DE0807F472ZAC250V !
C506	459-B247R-00	DE0807F472ZAC250V !
C303	459-D210M-00	MSC46-01A
C313	459-5133K-00	RQC05B331K-H46CA
C524	459-6147K-00	DE0705B471K1k
C309	459-6147K-00	DE0705B471K1k
C521	459-6215K-00	DE0905B152K1K
C328	459-8147K-00	DE0707B471K2K
C512	459-8215K-00	DE1007B152K2K
C304	459-9118K-00	CT81-11C-Bn-3KV-181K
THIN-FILM CAPACITOR		
C339	462-B0410-H0	CL21X-50V-0.1uF-J
C202	462-B0447-H0	CL21X-50V-0.47uF-J
C804	462-00215-K0	CL11-100V-1500PF-K
C803	462-00227-K0	CL11-100V-2700PF-K
C203	462-00282-H0	CL11-100V-8200pF-J
C122	462-00282-H0	CL11-100V-8200pF-J
C134	462-00282-H0	CL11-100V-8200pF-J
C502	462-2B410-M0V	250VAC-0.1uF-M !
C505	462-2B410-M0V	250VAC-0.1uF-M !
C509	462-2B410-M0V	250VAC-0.1uF-M !
C500	462-2B410-M0V	250VAC-0.1uF-M !
C821	462-26310-K0	CL21-630V-0.01uF-K
C319	462-8E282-H0	CBB81-2KV-8200PF-J
C324	462-8E282-H0	CBB81-2KV-8200PF-J
C301	462-83356-H0	CBB21-200V-0.056uF-J
C323	462-83433-H0	CBB21-200V-0.33uF-J
C333	462-85318-H0	CBB21-400V-0.018uF-J
C325	462-85322-H0	CBB21-400V-0.022uF-J
C360	462-85333-H0	CBB21-400V-0.033uF-J
C327	462-85356-H0	CBB21-400V-0.056uF-J
C332	462-85433-H0	CBB21-400V-0.33uF-J
C226	462-B0410-H02	CL21X-50V-0.1uF-J
C361	462-B0410-H02	CL21X-50V-0.1uF-J

SYMBOL	PART NO.	DESCRIPTION
C104	462-B0410-H02	CL21X-50V-0.1uF-J
C115	462-B0410-H02	CL21X-50V-0.1uF-J
C513	462-B0410-H02	CL21X-50V-0.1uF-J
C114	462-B0410-H02	CL21X-50V-0.1uF-J
C306	462-B0422-H02	CL21X-50V-0.22uF-J
C651	462-00210-H02	CL11-100V-1000PF-J
C517	462-00210-H02	CL11-100V-1000PF-J
C338	462-00222-H02	CL11-100V-2200PF-J
C112	462-00222-H02	CL11-100V-2200PF-J
C322	462-00222-K02	CL11-100V-2200PF-K
C311	462-00247-K02	CL11-100V-4700PF-K
C364	462-00256-H02	CL11-100V-5600PF-J
C526	462-00256-H02	CL11-100V-5600PF-J
C646	462-00310-H02	CL11-100V-0.01uF-J
C636	462-00310-H02	CL11-100V-0.01uF-J
C637	462-00310-H02	CL11-100V-0.01uF-J
C638	462-00310-H02	CL11-100V-0.01uF-J
C641	462-00310-H02	CL11-100V-0.01uF-J
C642	462-00310-H02	CL11-100V-0.01uF-J
C643	462-00310-H02	CL11-100V-0.01uF-J
C644	462-00310-H02	CL11-100V-0.01uF-J
C650	462-00310-H02	CL11-100V-0.01uF-J
C236	462-00310-H02	CL11-100V-0.01uF-J
C237	462-00310-H02	CL11-100V-0.01uF-J
C126	462-00322-H02	CL11-100V-0.022uF-J
C123	462-00327-H02	CL11-100V-0.027uF-J
C116	462-00333-H02	CL11-100V-0.033uF-J
C118	462-00333-H02	CL11-100V-0.033uF-J
C109	462-00333-H02	CL11-100V-0.033uF-J
C124	462-00333-H02	CL11-100V-0.033uF-J
C363	462-00333-H02	CL11-100V-0.033uF-J
C125	462-00347-H02	CL11-100V-0.047uF-J
ELECTROLYTIC CAPACITOR		
C336	464-V1610-T0	CD111HR-100V-10uF-T
C530	464-04747-M0R	200USP470MA35
C514	464-07733-M0N	CD293X-400V-330uF-M
C337	464-3D610-M0	CD11W-16V-10uF-M
C217	464-3D610-M0	CD11W-16V-10uF-M
C206	464-6D710-M0	CD110-16V-100uF-M
C212	464-6D722-M0	CD110-16V-220uF-M
C230	464-6D722-M0	CD110-16V-220uF-M
C629	464-6D747-M0	CD110-16V-470uF-M
C110	464-6D747-M0	CD110-16V-470uF-M
C535	464-6D810-M0	CD110-16V-1000uF-M

SYMBOL	PART NO.	DESCRIPTION
C534	464-6D810-M0	CD110-16V-1000uF-M
C532	464-6F710-M0	CD110-35V-100uF-M
C103	464-6F747-M0	CD110-35V-470uF-M
C102	464-6F747-M0	CD110-35V-470uF-M
C302	464-6F810-M0	CD110-35V-1000uF-M
C138	464-6F810-M0	CD110-35V-1000uF-M
C321	464-6F810-M0	CD110-35V-1000uF-M
C531	464-6F810-M0	CD110-35V-1000uF-M
C208	464-60510-M0	CD110-50V-1uF-M
C209	464-60510-M0	CD110-50V-1uF-M
C210	464-60510-M0	CD110-50V-1uF-M
C211	464-60510-M0	CD110-50V-1uF-M
C331	464-65547-M0	CD288-250V-4.7uF-M
C315	464-65633-M0	CD288-250V-33uF-M
C312	464-65633-M0	CD288-250V-33uF-M
C129	464-6D547-M02	CD110-16V-4.7uF-M
C232	464-6D547-M02	CD110-16V-4.7uF-M
C820	464-6D610-M02	CD110-16V-10uF-M
C634	464-6D647-M02	CD110-16V-47uF-M
C610	464-6D710-M02	CD110-16V-100uF-M
C549	464-6D710-M02	CD110-16V-100uF-M
C220	464-6D710-M02	CD110-16V-100uF-M
C117	464-6D710-M02	CD110-16V-100uF-M
C633	464-6D710-M02	CD110-16V-100uF-M
C219	464-6D710-M02	CD110-16V-100uF-M
C540	464-6D710-M02	CD110-16V-100uF-M
C546	464-6D710-M02	CD110-16V-100uF-M
C818	464-6D710-M02	CD110-16V-100uF-M
C810	464-6D710-M02	CD110-16V-100uF-M
C231	464-6D722-M02	CD110-16V-220uF-M
C205	464-6D733-M02	CD110-16V-330uF-M
C550	464-6D747-M02	CD110-16V-470uF-M
C602	464-6E610-M02	CD110-25V-10uF-M
C623	464-6E610-M02	CD110-25V-10uF-M
C625	464-6E610-M02	CD110-25V-10uF-M
C802	464-6E610-M02	CD110-25V-10uF-M
C626	464-6E610-M02	CD110-25V-10uF-M
C631	464-6E610-M02	CD110-25V-10uF-M
C630	464-6E610-M02	CD110-25V-10uF-M
C654	464-6E647-M02	CD110-25V-47uF-M
C365	464-6E710-M02	CD110-25V-100uF-M
C314	464-6E722-M02	CD110-25V-220uF-M
C120	464-6F610-M02	CD110-35V-10uF-M
C133	464-6F610-M02	CD110-35V-10uF-M

SYMBOL	PART NO.	DESCRIPTION
C121	464-6F610-M02	CD110-35V-10uF-M
C132	464-6F610-M02	CD110-35V-10uF-M
C130	464-6F610-M02	CD110-35V-10uF-M
C131	464-6F610-M02	CD110-35V-10uF-M
C310	464-6F710-M02	CD110-35V-100uF-M
C536	464-6F710-M02	CD110-35V-100uF-M
C640	464-60447-M02	CD110-50V-0.47uF-M
C204	464-60447-M02	CD110-50V-0.47uF-M
C224	464-60447-M02	CD110-50V-0.47uF-M
C601	464-60510-M02	CD110-50V-1uF-M
C213	464-60510-M02	CD110-50V-1uF-M
C111	464-60510-M02	CD110-50V-1uF-M
C113	464-60510-M02	CD110-50V-1uF-M
C620	464-60510-M02	CD110-50V-1uF-M
C616	464-60510-M02	CD110-50V-1uF-M
C613	464-60510-M02	CD110-50V-1uF-M
C624	464-60510-M02	CD110-50V-1uF-M
C801	464-60510-M02	CD110-50V-1uF-M
C128	464-60533-M02	CD110-50V-3.3uF-M
C305	464-60547-M02	CD110-50V-4.7uF-M
C635	464-60610-M02	CD110-50V-10uF-M
C645	464-60610-M02	CD110-50V-10uF-M
C652	464-60610-M02	CD110-50V-10uF-M
C612	464-60610-M02	CD110-50V-10uF-M
C614	464-60610-M02	CD110-50V-10uF-M
C615	464-60610-M02	CD110-50V-10uF-M
C617	464-60610-M02	CD110-50V-10uF-M
C619	464-60610-M02	CD110-50V-10uF-M
C621	464-60610-M02	CD110-50V-10uF-M
C221	464-60610-M02	CD110-50V-10uF-M
C541	464-60610-M02	CD110-50V-10uF-M
C307	464-60610-M02	CD110-50V-10uF-M
C320	464-60610-M02	CD110-50V-10uF-M
C366	464-60610-M02	CD110-50V-10uF-M
C229	464-60647-M02	CD110-50V-47uF-M
C101	464-60710-M02	CD110-50V-100uF-M
C542	464-60710-M02	CD110-50V-100uF-M
C330	464-62510-M02	CD288-160V-1uF-M
C515	464-YG710-M0	CD110LZ-63V-100uF-M
INDUCTANCE WITH COLOUR CODES		
L203	471-1056K-00	EL0606SKI-560K
L616	471-1110H-00	EL0606SKI-101J
L802	471-1110H-00	EL0606SKI-101J
L201	471-1110H-00	EL0606SKI-101J

SYMBOL	PART NO.	DESCRIPTION
L609	471-1110H-00	EL0606SKI-101J
L613	471-1110H-00	EL0606SKI-101J
L612	471-2012K-A0	SP0203-12uH-K
L614	471-2015K-A0	SP0203-15uH-K
L615	471-2027K-A0	SP0203-27uH-K
L202	471-2056H-60	LGA0307-56uH-J
L101	471-2056H-60	LGA0307-56uH-J
L801	471-2056H-60	LGA0307-56uH-J
L204	471-2056H-60	LGA0307-56uH-J
L206	471-2056H-60	LGA0307-56uH-J
L601	471-2056H-60	LGA0307-56uH-J
L208	471-2B56K-003	SPT0305-R56K-5
L205	471-2B56K-003	SPT0305-R56K-5
L603	471-2010K-003	SPT0305-100K-5
L604	471-2010K-003	SPT0305-100K-5
L607	471-2010K-003	SPT0305-100K-5
L608	471-2010K-003	SPT0305-100K-5
L207	471-2068K-003	SPT0305-680K-5
L606	471-2110K-003	SPT0305-101K-5
L611	471-2110K-003	SPT0305-101K-5
IC		
D209	352-05740-00	uPC574
N502	352-06210-70	TLP621-GB(UL)
N102	352-13040-90	TA1304N
N801	352-24080-50	M24C08BN6
N603	352-40530-00	TC4053BP
N601	352-52797-20	M52797SP
N101	352-75820-10	AN7582
N301	352-78041-00	LA78041
N503	352-78050-00	KA7805
N201	352-88070-00	TMPA8807PSAN
N602	352-90450-50	TC90A45P
N501	352-96560-00	STR-G9656
RELAY		
RY1	457-12003-9G	JQX-14FF-012-1HS !
SAW FILTER		
Z201	458-07008-00	M1962M
WIRE-ROUND RESISTOR		
R302	467-AF001-H0	RX21F-1W-1Ω-JL
METAL RESISTOR		
R525	467-2D239-H0	1/4W-3.9K-J
R303	467-2D310-H0	1/4W-10K-J
R306	467-2D311-H0	1/4W-11K-J

SYMBOL	PART NO.	DESCRIPTION
R524	467-2D415-H0	1/4W-150K-J
R305	467-2EB82-H0	1/2W-0.82Ω-JL
R304	467-2E001-H0	1/2W-1Ω-JL
R532	467-2E136-H0	1/2W-360Ω-JL
R533	467-2E182-H0	1/2W-820Ω-JL
R361	467-2E333-H0	1/2W-33K-JL
R522	467-2F012-H0	1W-12Ω-JL
R324	467-2F210-H0	1W-1KΩ-JL
R317	467-2F310-H0	1W-10kΩ-JL
R511	467-2F333-H0	1W-33kΩ-JL
R509	467-2F347-H0A	1W-47kΩ-J
R339	467-2F351-H0	1W-51kΩ-JL
R508	467-2F351-H0A	1W-51kΩ-J
R526	467-2F382-H0	1W-82kΩ-JL
R506	467-2GA01-H2	RY21-2W-0.1Ω-JL
R341	467-2GA56-H0	2W-5.6Ω-JL
R527	467-2H115-H0D	3W-150Ω-JL
R301	467-2G127-H0	2W-270Ω-JL
R332	467-2G291-H0	2W-9.1kΩ-JL
R535	467-2G320-H0	2W-20K-JL
R333	467-20239-HB	RYG2-5W-3.9K-J-A
MELTABLE RESISTOR		
R313	467-4FA24-H0	1W-2.4Ω-JL
R519	467-4FB33-H0	1W-0.33Ω-JL
R322	467-4F001-H0	1W-1Ω-JL
R315	467-4F001-H0	1W-1Ω-JL
R308	467-4F010-H0	1W-10Ω-JL
R312	467-4F001-H0	1W-1Ω-JL
R517	467-4F001-H0	1W-1Ω-JL
CEMENT RESISTOR		
R377	467-50A56-HD	RX27-3-5-5.6Ω-J
CARBON RESISTOR		
R345	467-8E227-H1A	1/2W-2.7KΩ-J !
R502	467-8E522-H0A	1/2W-2.2M-J !
R515	467-8E582-H0A	1/2W-8.2MΩ-J !
POTENTIOMETER		
RP501	468-02101-00	WI02A-2-1KB
THERMISTOR		
R503	469-10023-00	96708 (9Ω)
R501	469-40004-00	5D2-14LC
SWITCH TRANSFORMER		
T502	470-00256-00	SD4917 !

SYMBOL	PART NO.	DESCRIPTION
H-DRIVE TRANSFORMER		
T303	472-10001-00	XR0961
DYNAMIC FOCUS TRANSFORMER		
T301	472-60001-00	EI28
CERAMIC FILTER		
Z202	475-15451-00	LT4.5MH
CERAMIC TRAP FILTER		
Z601	475-25451-00	XT4.5MB
H-LINEARITY COIL		
L303	477-00040-00	TLN3745
POWER FILTER		
T500	477-20005-00	LF21061 !
T501	477-20031-00	LCL-21 !
INDUCTANCE		
L301	477-30011-00	TLN2110
FIXED INDUCTANCE		
L307	477-40057-00	1735
L306	477-40073-00	TLN3197D
L305	477-40128-00	LE1940
FBT		
T302	472-27122-00	BSC29-3914C !
OTHER		
TUNER	590-40713-00	TDQ-3B8G/134X !
POWER CORD	491-7521C-02	UL !
FU501	569-18101-00	51S 5A/125V !
DEGAUSSING COIL	477-12904-00	DX-29!
CRT	335-29327-00	A68LTF-356X01(Y)(UL) !

CRT BOARD

SYMBOL	PART NO.	DESCRIPTION
	782-W2935-020	CRT PCB
DIODE		
D401	340-00001-00	1N4148
D402	340-00001-00	1N4148
D403	340-00001-00	1N4148
D404	340-00001-00	1N4148
D405	340-00001-00	1N4148
D407	340-00001-00	1N4148
D408	340-00001-00	1N4148
D409	340-00001-00	1N4148
D410	340-00001-00	1N4148

SYMBOL	PART NO.	DESCRIPTION
TRANSISTOR		
V411	343-05620-10	2SA562TM-Y
V415	343-10150-10	2SA1015Y
V422	343-10150-10	2SA1015Y
V401	343-18150-11	2SC1815-Y
V402	343-18150-11	2SC1815-Y
V404	343-18150-11	2SC1815-Y
V406	343-18150-11	2SC1815-Y
V408	343-18150-11	2SC1815-Y
V409	343-18150-11	2SC1815-Y
V410	343-18150-11	2SC1815-Y
V413	343-18150-11	2SC1815-Y
V414	343-18150-11	2SC1815-Y
V416	343-19640-30	2SA1964E
V403	343-26880-60	2SC2688M
V405	343-26880-60	2SC2688M
V407	343-26880-60	2SC2688M
V417	343-52480-30	2SC5248E
CRT SOCKET		
X404	364-58210-00	GZS10-2-102G !
CERAMIC CAPACITOR		
C446	459-2082H-10	CC1-08-63V-82pF-J
C447	459-2082H-10	CC1-08-63V-82pF-J
C448	459-2082H-10	CC1-08-63V-82pF-J
C419	459-2110H-10D	CC1-08-CH-63V-101J
C420	459-2110H-10D	CC1-08-CH-63V-101J
C403	459-2127H-90	CC1-08-SL-63V-271J
C405	459-2127H-90	CC1-08-SL-63V-271J
C406	459-2127H-90	CC1-08-SL-63V-271J
C409	459-2147H-90	CC1-12-SL-63V-471J
C410	459-2147H-90	CC1-12-SL-63V-471J
C411	459-2147H-90	CC1-12-SL-63V-471J
C414	459-2156H-90	CC1-12-SL-63V-561J
C417	459-2210K-00	CT1-06-2B4-63V-102K
C421	459-2247R-00	CT1-08-2E4-63V-472Z
C422	459-2247R-00	CT1-08-2E4-63V-472Z
C404	459-2310R-00	CT1-08-2F4-63V-103Z
C412	459-2310R-00	CT1-08-2F4-63V-103Z
C426	459-5056H-90	CC45SL2H560JYJ
C424	459-8222K-00	DE1005B222K2K
THIN-FILM CAPACITOR		
C402	462-00282-H0	CL11-100V-8200pF-J

SYMBOL	PART NO.	DESCRIPTION
ELECTROLYTIC CAPACITOR		
C423	464-6D647-M0	CD110-16V-47uF-M
C425	464-6D647-M0	CD110-16V-47uF-M
C415	464-6D722-M0	CD110-16V-220uF-M
C401	464-6E610-M0	CD110-25V-10uF-M
C407	464-6E710-M0	CD110-25V-100uF-M
C418	464-62610-M0	CD288-160V-10uF-M
C427	464-62610-M0	CD288-160V-10uF-M
C416	464-65633-M0	CD288-250V-33uF-M
METAL RESISTOR		
R443	467-2E010-H0	1/2W-10Ω-JL
R401	467-2E047-H0	1/2W-47Ω-JL
R444	467-2E133-H0	1/2W-330Ω-JL
R458	467-2F122-H0	1W-220Ω-JL
R432	467-2G312-H0	2W-12kΩ-JL
R434	467-2G312-H0	2W-12kΩ-JL
R437	467-2G312-H0	2W-12kΩ-JL
MELTABLE RESISTOR		
R442	467-4FA15-H0	1W-1.5Ω-JL
CARBON RESISTOR		
R433	467-8E227-H1A	1/2W-2.7KΩ-J !
R435	467-8E227-H1A	1/2W-2.7KΩ-J !
R436	467-8E227-H1A	1/2W-2.7KΩ-J !
INDUCTANCE WITH COLOUR CODES		
L401	471-1056H-00	EL0606SKI-560J
L402	471-2110K-00	SPT0305-101K-5

BUTTON BOARD

SYMBOL	PART NO.	DESCRIPTION
	782-Q2735-0500	BUTTON PCB
LIGHT-EMITTING DIODE		
VD902	340-10055-90	HFT505M
VD901	340-10021-50	2EF565 (GREEN)
TRANSISTOR		
V901	343-10150-10	2SA1015Y
IC		
RC901	352-00380-00	HS0038 (D)

SIDE AV PCB

SYMBOL	PART NO.	DESCRIPTION
	782-Q2735-2900	SIDE AV PCB
METAL RESISTOR		
RAA8	467-2F133-H0	1W-330Ω-JL
RAA9	467-2F133-H0	1W-330Ω-JL
INDUCTANCE WITH COLOUR CODES		
LAA1	471-2001K-00	SPT0305-1R0K-5
LAA2	471-2001K-00	SPT0305-1R0K-5

STEREO BOARD

SYMBOL	PART NO.	DESCRIPTION
	782-Q2735-310A	STEREO PCB
TRANSISTOR		
VS01	343-18150-104	2SC1815-Y
VS02	343-18150-104	2SC1815-Y
INDUCTANCE WITH COLOUR CODES		
LS01	471-2068K-103	LGA0410-68uH-K
IC		
NS01	352-58320-50	AN5832SA (D)