

COLOR TELEVISION

SERVICE MANUAL

SERVICE MANUAL



IS-TVHD30

CONTENTS

Safety precautions.....	1
Alignment instructions.	3
Working principle analysis of the unit.....	10
Block diagram.....	11
IC block diagram.....	12
Wiring diagram	18
Troubleshooting.....	19
Schematic diagram.	21

Attention: This service manual is only for service personnel to take reference with. Before servicing please read the following points carefully.

Safety precautions

After the original service problem has been corrected, a check should be made of the following:

FIRE & SHOCK HAZARD

1. Be sure that all components are positioned in such a way as to avoid possibility of adjacent component shorts. This is especially important on those chassis, which are transported to and from the repair shop.
2. Never release a repair unless all protective devices such as insulators, barriers, covers, shields, strain reliefs, and other hardware have been reinstalled per original design.
3. Soldering must be inspected to discover possible cold solder joints, frayed leads, damaged insulation (including A.C. cord), solder splashes or sharp solder points. Be certain to remove all loose foreign particles.
4. Check for physical evidence of damage or deterioration to parts and components, and replace if necessary follow original layout, lead length and dress.
5. No leads or components should touch a receiving tube or a resistor rated at 1 watt or more. Lead tension around protruding metal surfaces must be avoided.
6. All critical components such as fuses, flameproof resistors, capacitors, etc. must be replaced with exact factory types. Do not use replacement components other than those specified or make unrecompensed circuit modifications.
7. After re-assembly of the set always perform an A.C. leakage test on all exposed metallic parts of the cabinet, (the channel selector knob, antenna terminals, handle and screws) to be sure the set is safe to operate without danger of electrical shock. **Do not use a line isolation transformer during this test.** Use an A.C. voltmeter, having 5000 ohms per volt or more sensitivity, in the following manner: connect a 1500ohm 10watt resistor, paralleled by a 0.15uF. 150V A.C. type capacitor between a known good earth ground (water pipe, conduit, etc. and the exposed metallic parts, one at a time. Measure the A.C. voltage across the combination of 1500ohm resistor and 0.15uF capacitor. Reverse the A.C. plug and repeat A.C. voltage measurements for each exposed metallic part. Voltage measured must not exceed 0.75 volts R.M.S. This corresponds to 0.5 milliamp A.C. Any value exceeding this limit constitutes a potential shock hazard and must be corrected immediately.

GRAPHIC SYMBOLS:



It is intended to alert the service personnel to the presence of uninsulated dangerous voltage that may be of sufficiently magnitude to constitute a risk of electric shock.



It is intended to alert the service personnel to the presence of important safety information in service literature.

X-RADIATION

Too excessive voltage will cause harmful X-ray. To avoid this radiation hazard, the high voltage should fall within the limitation. The appliance works at AC 120V, 60Hz. The high voltage of zero

beam current should be within 35KV on condition that the main power(B+) voltage is DC140V. And it should not exceed 36KV in any condition.

1. Be sure procedures and instructions to all service personnel cover the subject of X-rays in current TV is the picture tube. However, this tube does not emit X-rays when the high voltage is at the factory specified level. The proper value is given in the applicable schematic. Operation at higher voltages may cause a failure of the picture tube or high voltage supply and, under certain circumstances, may produce radiation in excess of desirable levels.
2. Only factory specified C.R.T. anode connectors must be used. Degaussing shields also serve as X-ray shield in color sets. Always re-install them.
3. It is essential that the serviceman has available an accurate and reliable high voltage meter. The calibration of the meter should be checked periodically against a reference standard. Such as the one available at your distributor.
4. When the high voltage circuitry is operating properly there is no possibility of an X-radiation problem. Every time a color chassis is serviced, the brightness should be run up and down while monitoring the high voltage with a meter to be certain that the high voltage does not exceed the specified value and that it is regulating correctly. We suggest that you and your service organization review test procedures so that voltage regulation is always checked as a standard servicing procedure. And that the high voltage reading be recorded on each customer s invoice.
5. When troubleshooting and making test measurements in a receiver with a problem of excessive high voltage, avoid being unnecessarily close to the picture tube and the high voltage compartment. Do not operate the chassis longer than is necessary to locate the cause of excessive voltage.
6. Refer to HV, B+ and Shutdown adjustment procedures described in the appropriate schematic and diagrams. Too excessive voltage will cause harmful X-ray.

IMPLOSION

1. All direct viewed picture tubes are equipped with an integral implosion protection system, but care should be taken to avoid damage during installation. Avoid scratching the tube. If scratched, replace it.
2. Use only recommended factory replacement tubes.

TIPS ON PROPER INSTALLATION

1. Never install any receiver in closed-in recess, cubbyhole or closely fitting shelf space over, or close to heat duct, or in the path of heated airflow.
2. Avoid conditions of high humidity such as: Outdoor patio installations where dew is a factor. Near steam radiators where steam leakage is a factor, etc.
3. Avoid placement where draperies may obstruct rear venting. The customer should also avoid the use of decorative scarves or other coverings which might obstruct ventilation.
4. Wall and shelf mounted installations using a commercial mounting kit, must follow the factory approved mounting instructions. A receiver mounted to a shelf or platform must retain its original feet(or the equivalent thickness in spacers) to provide adequate air flow across the bottom, bolts or screws used for fasteners must not touch and parts or wiring. Perform leakage test on customized installations.
5. Caution customers against the mounting of a receiver on sloping shelf or a tilted position, unless the receiver is properly secured.
6. A receiver on a roll-about cart should be stable on its mounting to the cart. Caution the customer on the hazards of trying to roll a cart with small casters across thresholds or deep pile carpets.

Alignment instructions

1. General instructions

1.1 The program data should be copied into the EEPROM (N802 M24C16) in this set according to Standard Sample program data, then execute "Factory Adjustment". If adopt empty EEPROM, please preset I2C datum before any debugging.

1.2 If there is no special notice, the unit adjustment should be done on the following conditions:

a. AC power 120V/60Hz.

b. Pre-heat the set for above 30 minutes.

1.3 There is a auto-degaussing circuit inside which could degauss the set automatically within one second after turn on the power. The auto-degaussing circuit effects on condition that every interval of turning on the set is longer than 30 minutes at least.

1.4 The magnetized CRT will influence the colour purity and focus. When the inside degaussing circuit can't degauss thoroughly then an outside degausser is necessary. Colour purity and focus adjustment should be executed according to the colour purity and focus adjusts procedures if the colour purity and focus is not good.

2. Alignment items and procedure

a) B+ voltage check

b) OSD character center adjustment

c) AFT and RFAGC voltage adjustment

d) Focus adjustment

e) Screen-grid voltage adjustment

f) White balance adjustment

g) Horizontal and vertical scanning centre and amplitude adjustment

h) Raster correction adjustment

i) HDTV white balance adjustment

j) HDTV Horizontal and vertical scanning centre and amplitude adjustment

k) HDTV raster correction adjustment

Adjustment flow-chart is shown as Fig-1

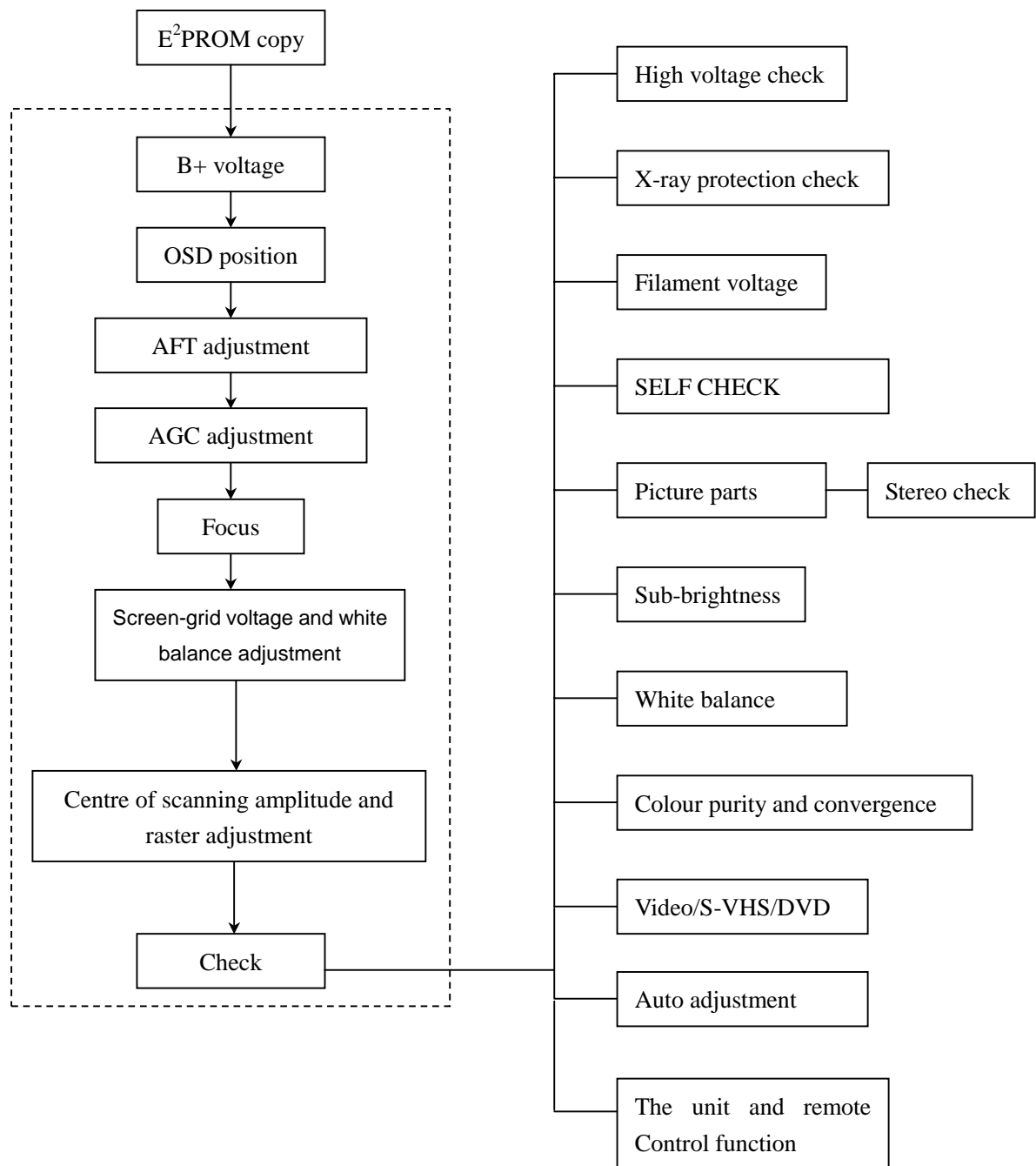

Fig-1 Adjustment flow-chart

3. Factory mode adjustment

3.1 Enter factory mode adjustment

Press the “factory menu” button on the remote control, the screen display the factory menu.

3.2 factory menu operation method

Press the channel +/- button to selection the sub menu of factory menu, and press the vol+/- to enter the sub menu or setting the value.

3.3 exit the factory menu

Press the MENU button again and again; it can exit the factory menu.

4. Adjustment methods

4.1 B+ voltage adjustment

- a. Be sure the voltage AC 120V/60Hz.
- b. Connect the digital voltmeter to TP3 and GND of B+ test point, input the US-7 signal, set the picture control to "standard", adjust RP501 to let the B+(test point) voltage 140V \pm 0.3V
- c. In the STAND BY turn off, B+ voltage about 20V

4.2 OSD position adjustment

In the factory menu, select SYS SETTING sub menu, adjust OSD H-POS item, let the character position to screen display center.

4.3 AFT adjustment

- a. IF of tuner (TUNER101) output and TP6 are separate.
- b. Input 45.75MHz of frequency and 90db of amplitude signals to TP6
- c. Adjust the tunable inductance L110, and measure between the TP4 and GND voltage, until the TP4 voltage to be 2.5V.
- d. Output pin IF of TUNER101 and TP6 bonding pad is normal.

4.4 AGC voltage adjustment

- a. Receive 60db split field signal
- b. Adjust the potentiometer RP101, and measure the TP5 to GND voltage, until the voltage of TP5 to be 3.5V, then noise wave of the picture point disappears.

4.5 focus adjustment

- a. Receive A28 signal, set the picture mode to standard.
- b. Adjust focus potentiometer of FBT, until the B area display best.

4.6 Screen-grid voltage and white balance adjustment

- a. Receive US-7 split field signal, the picture mode to "warm".
- b. In the factory menu, select the WHITE BALANCE SETTING menu, fixed the CUT OFF R and adjust the CUT OFF G and the CUT OFF B, until the white balance is normal.
- c. Select the color and contrast to 0, select the brightness to 50 in the user menu. In the factory menu, select the LUMINANCE SETTING menu; adjust the Brightness min, until the back level voltage about 180V. Adjust the SCREEN potentiometer, until rightmost of gray of the US-7 picture up and down separate.
- d. Select the color to 0, the brightness to 50 and the contrast to 100 in the user menu, adjust the Contrast max, until the eight level gray amplitude Vp-p to 100V.
- e. Select the color to 0, the brightness and the contrast to 100 in the user menu, adjust the BRIGHTNESS max, until low right back color of the D-8 picture does not white.
- f. In the factory menu, select the WHITE BALANCE SETTING sub menu; adjust the white balance (color temperature to 12000K \pm 8MPCD, the color coordinate to 0.270 \pm 0.008, 0.283 \pm 0.008).

4.7 Horizontal and vertical scanning centre adjustment of TV

4.7.1 Horizontal center adjustment

Receive A6 signal, the picture mode to "STANDARD" in the factory menu, select Horizontal setting menu, adjust the H POS, until the picture H-center and screen center accord.

4.7.2 Vertical center adjustment

Receive A6 signal, the picture mode to "STANDARD" in the factory menu, select Vertical setting menu, adjust the V POS, until the picture V-center and screen center accord.

4.8 Vertical scanning adjustment

Receive A12 signal, the picture mode to "STANDARD" in the factory menu, select Vertical setting

menu, adjust the V SIZE, until up and down over scanning of the picture to 8% of the all screen.

4.9 Raster correction and horizontal amplitude adjustment of TV

Receive white grid of NTSC signal, the picture mode to "STANDARD" in the factory menu, select horizontal setting menu, adjust the PCC, until the raster distort least, adjust the H SIZE, until right and left over scanning of the picture to 8% of the all screen.

4.10 If the scanning line distortion and raster geometric distortion dissatisfy condition, you can adjust the factory menu item

SCOR	S-Correction
CCOR	C-Correction
PCAC	Pin Cushion Asymmetry Correction
PCC	Pin Cushion Correction
KEYST	Keystone Correction
PARAL	Parallelogram Correction
TCC	Top Corner Correction
BCC	Bottom Corner Correction

4.11 Output the max sound of power

Receive the US-7 signal; adjust the volume to max, check the sound power output no less than 2 x 6W.

4.12 White balance and Horizontal and vertical scanning centre and amplitude adjustment of HDTV

The unit has the YPBPR terminal; it can display the HDTV signal

Support the HDTV and TIMING of the VG848 format.

Support input signal of YPbPr	
Signal format	TIMING of the VG848 format
480I	950
480P	978
576I	969
576P	979
1080I/60Hz	972
720P/60Hz	976
1080P/60Hz	970

When the white balance adjustment, the picture mode to STANDARD in the user mode. When The H-V scanning adjustment, set the H-CENTER, H-amplitude, V-CENTER and V-amplitude to 0 in the user menu.

4.12.1 YPbPr input (480p signal)

a. White balance adjustment

Input eight level gray of 480p format signal to HDTV YPbPr terminal, the picture mode to STANDARD.

In the factory menu, select the WHITE BALANCE SETTING menu; adjust the white balance (color temperature to 12000K+/-8MPCD, the color coordinate to 0.270+/-0.008, 0.283+/-0.008).

b. H-CENTER adjustment

Input white grid of 480p format signal to HDTV YPbPr terminal, the picture mode to STANDARD.

In the factory menu, select Horizontal setting menu, adjust the H POS, until the picture H-center and screen center accord.

c. V-CENTER adjustment

In the factory menu, select Vertical setting menu, adjust the V POS, until the picture V-center and screen center accord.

d. V-SCANNING adjustment

In the factory menu, select Vertical setting menu, adjust the V SIZE, until up and down over scanning of the picture to 8% of the all screen.

e. Raster correction and horizontal amplitude adjustment

Receive white grid of NTSC signal, the picture mode to "STANDARD" in the factory menu, select horizontal setting menu, adjust the PCC, until the raster distort least, adjust the H SIZE, until right and left over scanning of the picture to 8% of the all screen.

f. If the scanning line distortion and raster geometric distortion dissatisfy condition, you can adjust the factory menu item

SCOR	S-Correction
CCOR	C-Correction
PCAC	Pin Cushion Asymmetry Correction
PCC	Pin Cushion Correction
KEYST	Keystone Correction
PARAL	Parallelogram Correction
TCC	Top Corner Correction
BCC	Bottom Corner Correction

4.12.2 YPbPr input (1080I/60Hz format signal)

Adjustment mode to 4.12.1

5. Check point

5.1 check the high voltage

- Check the second anode and GND connect to the high voltmeter
- Receive US-7 signal, the picture mode to STANDARD, measure the high voltage to 30.0KV+/-1KV.
- The brightness and contrast to min value, while measure the high voltage no more than 35KV.

5.2 check the CRT Filament voltage

Receive the US-7 signal, the picture mode to STANDARD item, measure the CRT filament voltage to be 6.3+/-0.2Vrms.

5.3 Check the X-ray protection

- Receive the US-7 signal, the picture to STANDARD item.
- Connect TP1 to TP2 point of short circuit; X-ray protection circuit must be operation.

5.4 Check the picture part

5.5 Check the sub-brightness

5.6 Check chromatic purity and converge

5.7 Check the VIDEO and audio input/output

5.8 Check the unit and the remote control function

6. Ex-factory pre-setting

7. Check the supply power (AC 100V-140V/60Hz)

APPX: horizontal and vertical scanning adjustment diagram

Function	Sad	Pin	Byte	Waveform	Effect on Screen
Vertical Size	07	VOut	x0000000		
			x1111111		
Vertical Position	08	VOut	x0000000		
			x1000000		
			x1111111		
S-correction	09	VOut	x0000000: Null		
			x1111111: Max.		
C-correction	0A	VOut	x0000000		
			x1000000: Null		
			x1111111		
Vertical moiré amplitude	0B	VOut	x0000000: Null		
			x1111111: Max.		

Function	Sad	Pin	Byte	Waveform	Effect on Screen
Horizontal size	10h	EWOuT	0000000x		
			1111111x		
Keystone correction	0D	EWOuT	x0000000		
			x1111111		
Pin cushion correction	0C	EWOuT	x0000000		
			x1111111		
Top corner correction	0E	EWOuT	x1111111		
			x0000000		
Bottom corner correction	0F	EWOuT	x1111111		
			x0000000		
Parallelogram correction	12h	Internal	x0000000		
			x1111111		
Pin cushion asymmetry correction	11h	Internal	x0000000		
			x1111111		

Working principle analysis of the unit

The unit is digital frequency conversion processing of 16bit bus control color television, it adopt high integrity digital processing chip EX-11 of TRIDENT, this chip has a A/D conversion, decoder and scaler. The MCU is 16bit parallel processor M16C of RENESAS.

The unit adopt frequency composition tuner, it can direct display frequency point of every channel. The decoder chip have digital comb filter, Y/C processing clean separation, chroma signal and non-crosstalk brightness signal. It adopts three 10bit A/D and D/A conversion to reality of the picture. The unit working a singles horizontal frequency, it has two YPBPR terminal inputs and support multi-high definition format (1080i60, 720p, 1080p and so on), it have picture freeze, dynamic digital code noise reduction, picture edge enhance, PULL-DOWN, 16:9 mode, timing turn off, rotate, CCD and V-CHIP functions and so on,

The audio processing adopt application specific IC M61519 of MITSUBISHI, it supports stereo, treble-bass volume control, volume balance, surround sound and over-bass sound functions and so on. The unit has two AV inputs, an S terminal input, two YCRCB/YPBPR terminal inputs and a video output.

The RF signal send to compose tuner TUNER101, its pin11 output 38M of IF signal. After the signal via pre-intermediate frequency amplifier circuit V101, it sends to the picture SAWF Z102 and sound SAWF Z101, their are contain two filter of single PAL and NTSC, it be controlled high-low level of the pin 75 of MCU output (the pin59 of main board X701). The Z101 output sends to the pin8 of N101(LA7566) and Z102 output sends to the pin5 and pin6 of N101. The N101 supports PAL and NTSC system, it be controlled high-low level of MCU (N707, M16C/30620SPGP) output. The level define as follow:

System	X701-pin55	X701-pin53	X701-pin51	X701-pin49
DK (6.5M)	0	1	1	0
I (6M)	1	0	0	1
BG (5.5M)	1	1	0	1
M(4.5M)	0	0	0	0

Note: 1-high level, 0-low level

The pin13 of tuner output video, the video send to the digital chip N700(EX-11). It have VIDEO, two AV input, S terminal input and two YCRCB/YPBPR input, it through matching circuit to N700. After it via bus control and digital processing to pin37, pin39 and pin41 of X701 socket output R, G and B signal (peak value to 0.8V) and the pin 48 and pin48 output V-SYNC and H-SYNC. The V-SYNC and H-SYNC send to deflection chip N302(STV9118), the pin26 of N302 output H-signal drive the V301(2SC5422) and H-deflection coil of picture tube. The pin24 of N302 output EW signal for raster geometry adjustment. After the R, G and B signal of digital board send to the pin1, pin3 and pin5 of pre-video amplifier N801(STV9211) form pin14, pin16 and pin18 output to CRT board. The N401 of CRT board to R,G,B signal amplify to peak value(about 100V), it send to cathode of the picture tube. The SIF of the SAWF output send to stereo decoder NS01(LA72700), then it output L/R of audio. The L/R audio of TV, AV/S input and YCRCB/YPBPR input send to sound processor N601(M61519). Through BUS control of N707 to select processing of N601 signal channel, the pin25 and pin18 of N601 output L/R audio send to N602 (TA8256BH), the pin8 and pin12 of N602 output L/R audio drive speaker. In the mute state, the N707 send high level to the pin5 of N602, but the power amplifier without signal.

Block diagram

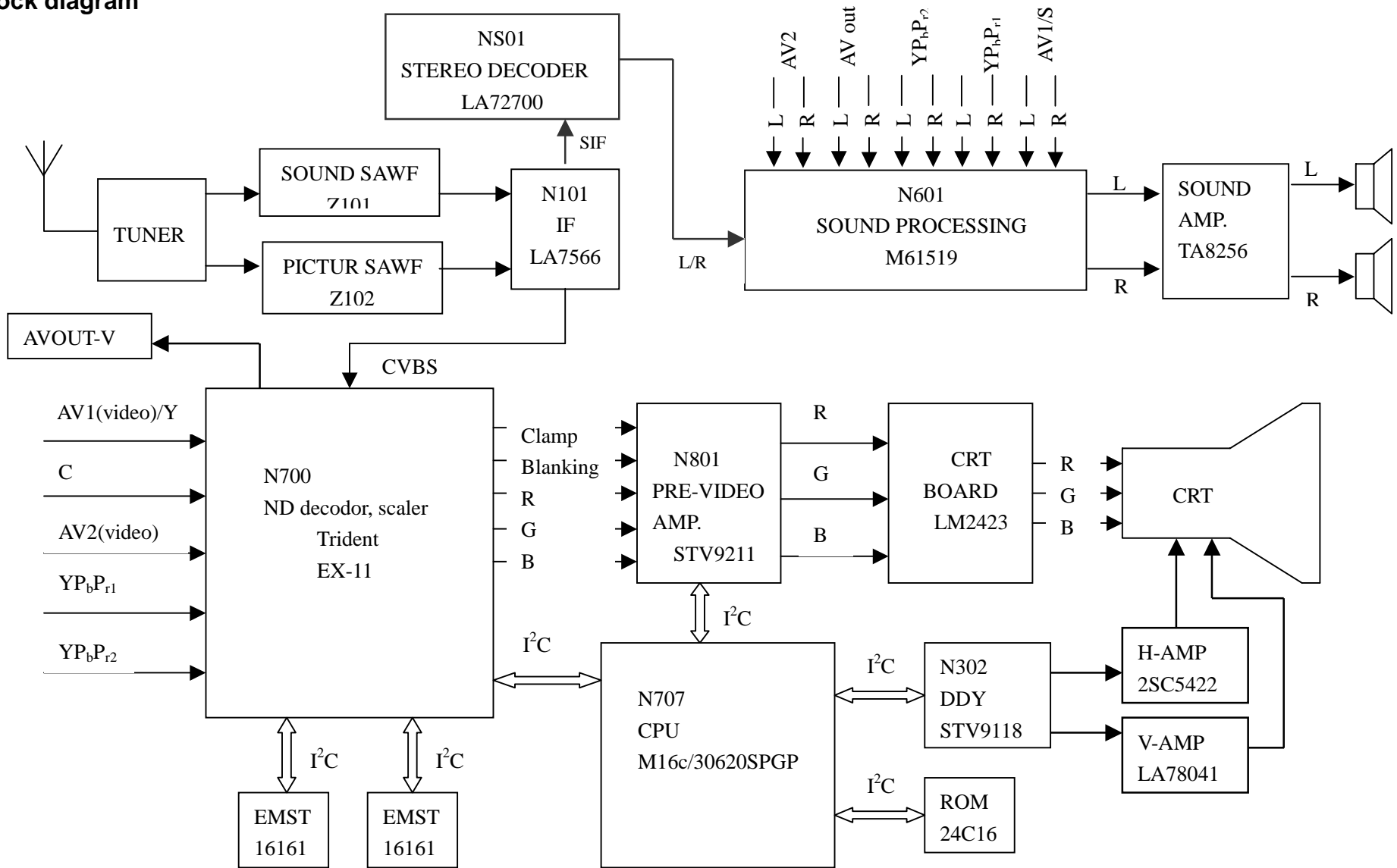

IC block diagram

1. LA7566

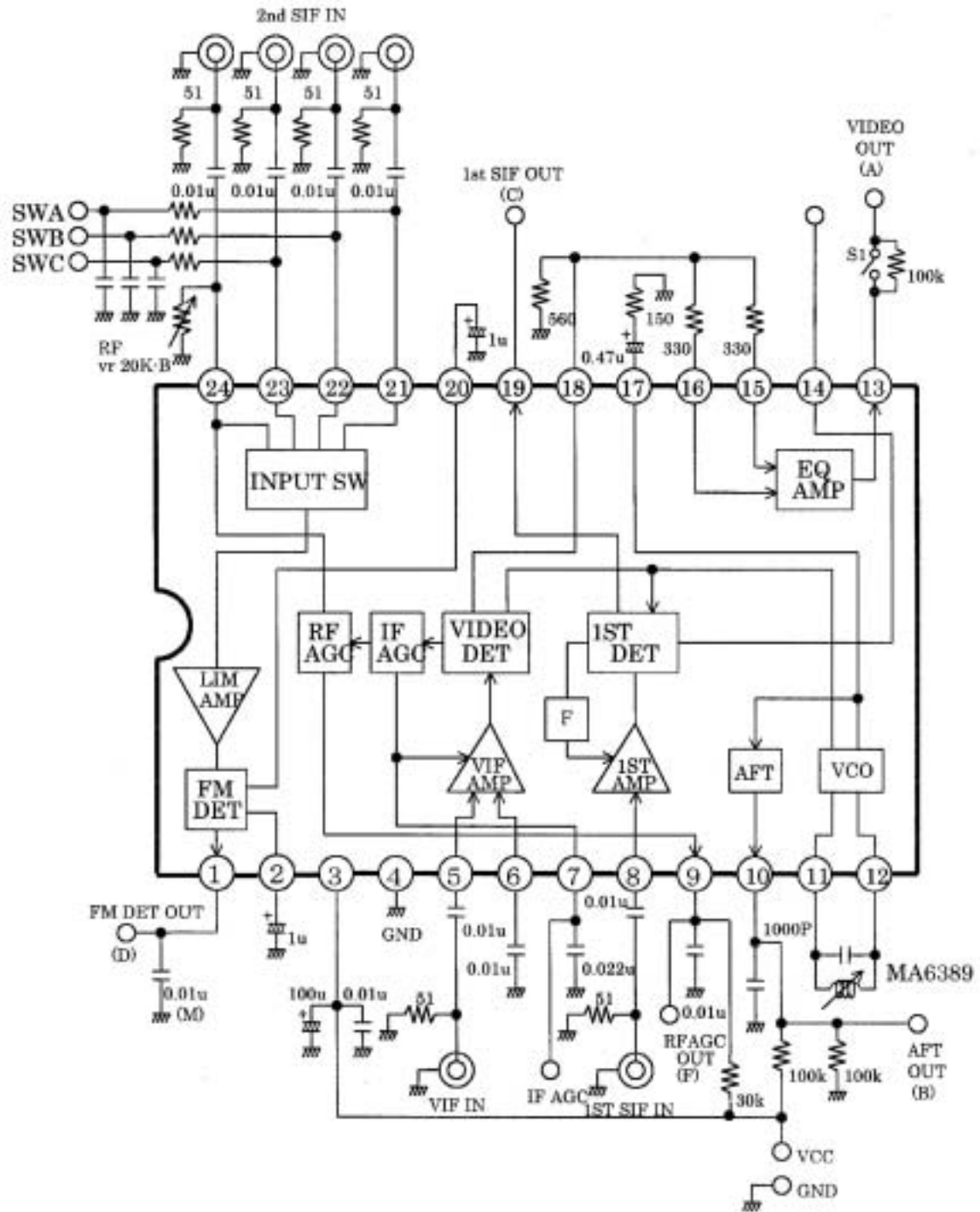

10: AFT output	19: SIF output
9: AGC output	1: TV audio output
5, 6: picture IF input	13: TV video output
8: sound IF input	3: 9V

2. EX-11

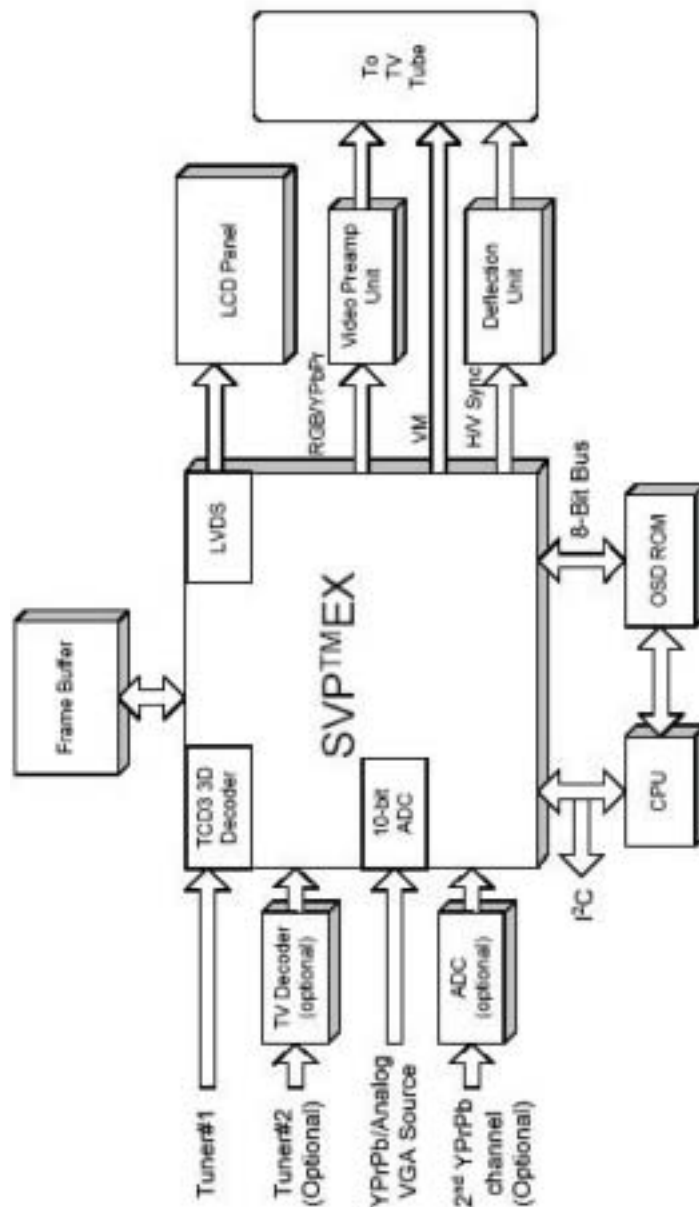

185: S-C input	187: Pb2 input
196: AV1-V/S-Y input	180: Pr2 input
197: AV2-V input	14: SCL
198: TV-V input	16: SDA
200: Y1(PbPr) input	190, 191: AVOUT-V output
186: Pb1 input	28: B output
179: Pr1 input	29: G output
202: Y2(PbPr) input	30: R output
34: H-SYNC output	31: VM output
37: V-SYNC output	9, 168 and so on: 1.8V
36: CLAMP output	15: 5V-1

3. M61519FP

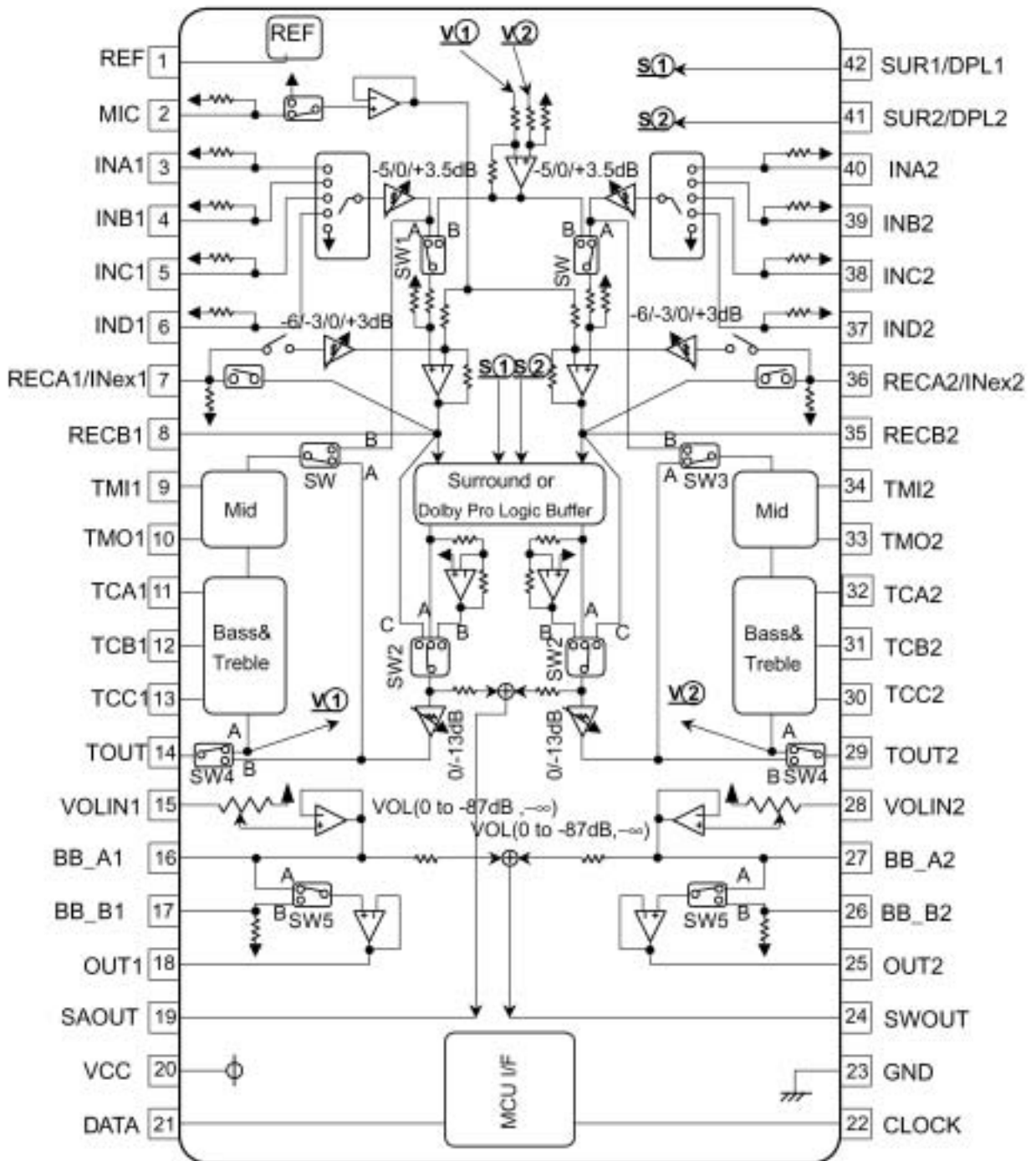

39: AV2 audio-L input	7: AV1/Saudio-R input
4: AV2aduion-R input	35: AVOUT audio-L output
6, 37: TV audio input	8: AVOUT audio-R output
38: YPbPr1audio-L input	11: audio-L output
5: YPbPr1audio-R input	19: audio-R output
40: YPbPr2audio-L input	22: CLOCK
3: YPbPr2audio-R input	21: DATA
36: AV1/Saudio-L input	20: 9V

4. STV9118

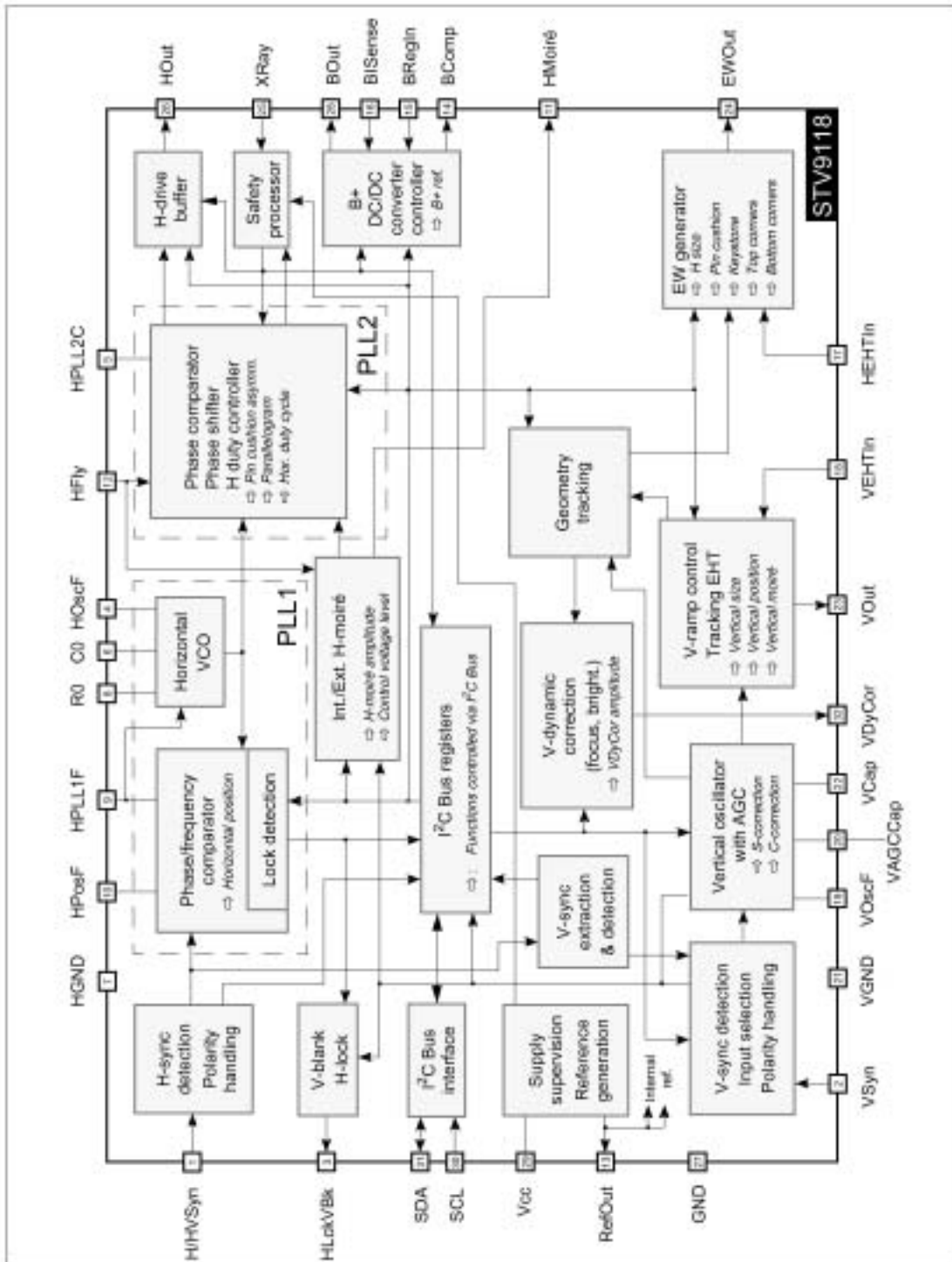

2: V-SYNC input	24: pincushion correction output
1 ; V-SYNC input	25: X-ray protection input
18: Vertical high voltage compensation input	31: SDA
17: Horizontal high voltage compensation input	30: SCL
26: horizontal signal output	29: 12V
23: vertical signal output	

5. STV9211

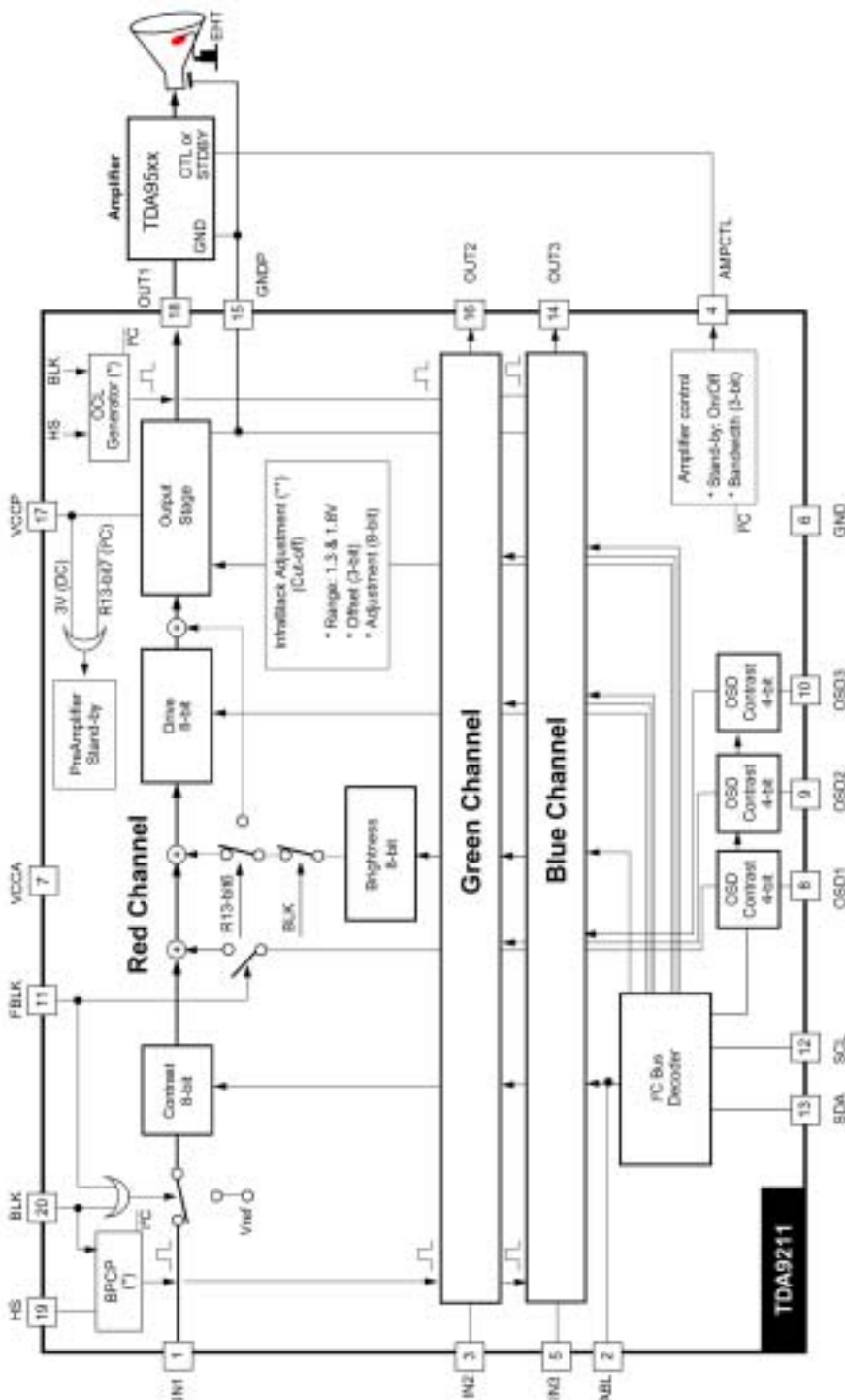

(*) See RGB Input section for complete BPCP and OCL description
 (***) See Cut-off adjustment section for complete Cut-off register description

1: R input	1: ABL
3: G input	5: B input
13: SDA	16: G output
19: CLAMP	14: B output
20: BLANK	7, 17: 5V
18: R output	12: SCL

6. LA72700V

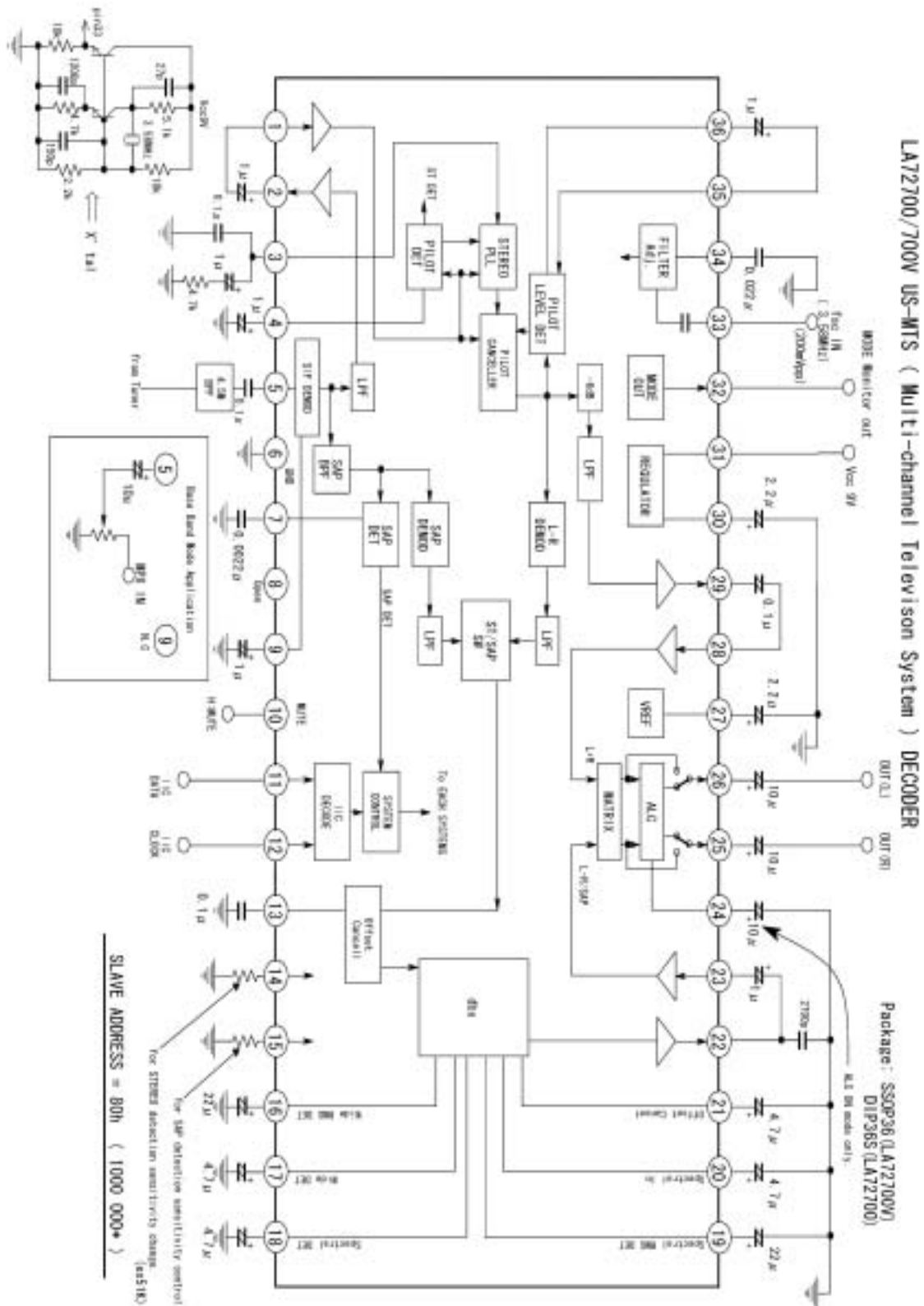

5: SIF input	25: R output
11: SDA	26: L output
12: SCL	31: 9V

Wiring diagram

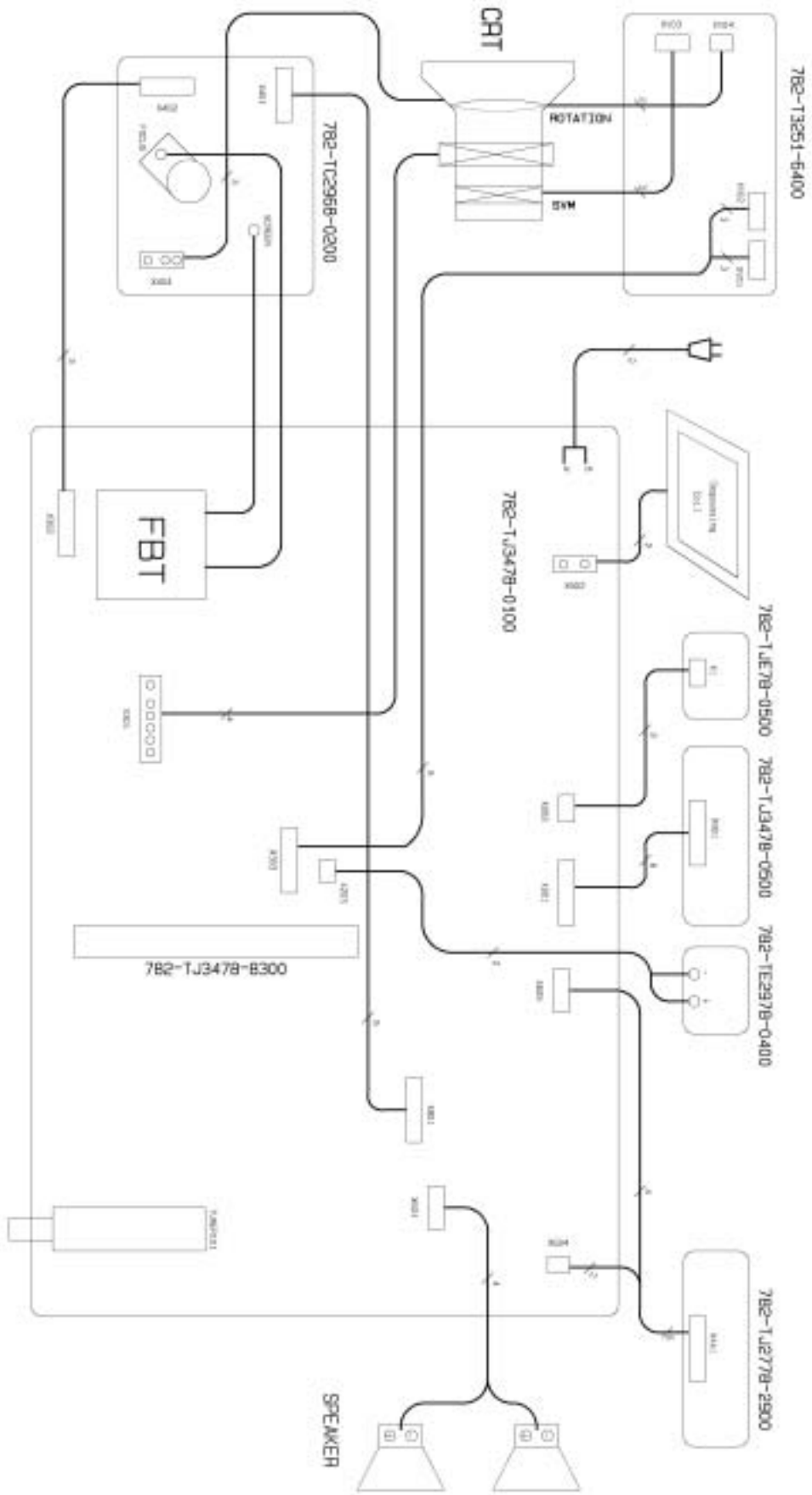

Trouble shooting

1. No raster, No picture and No sound

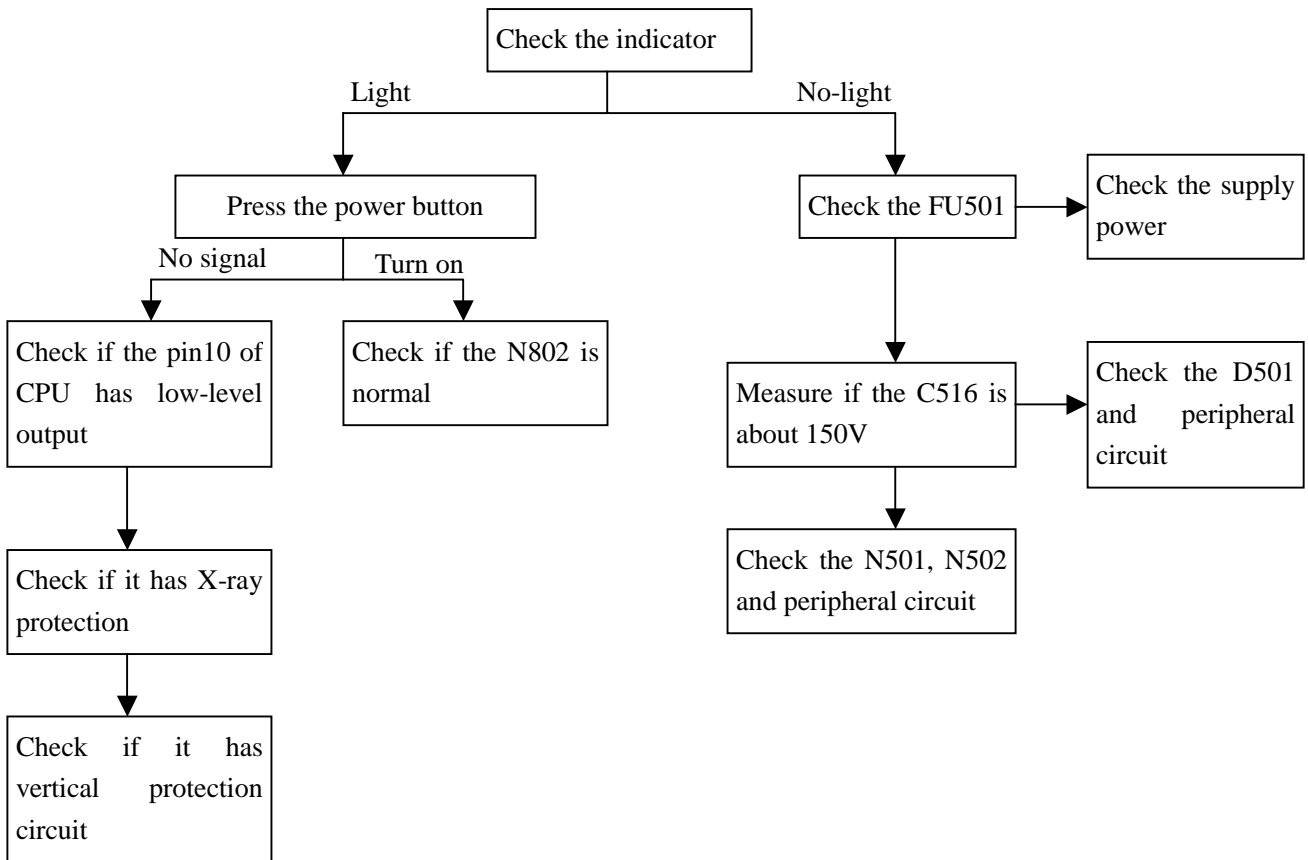

2. Picture, but without sound

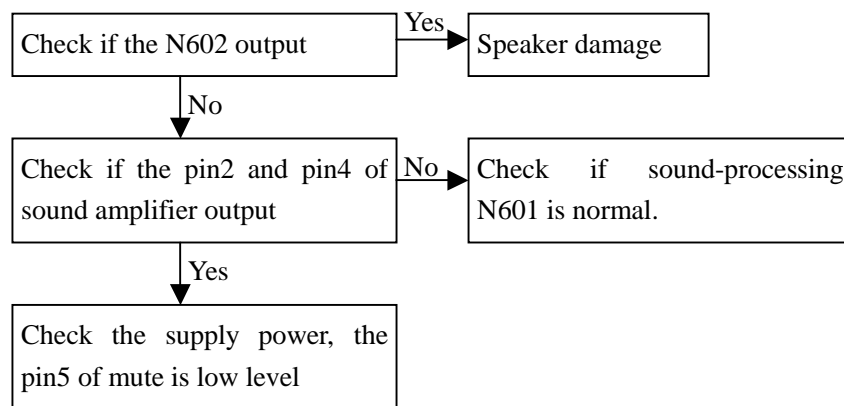

3. Sound, but without picture

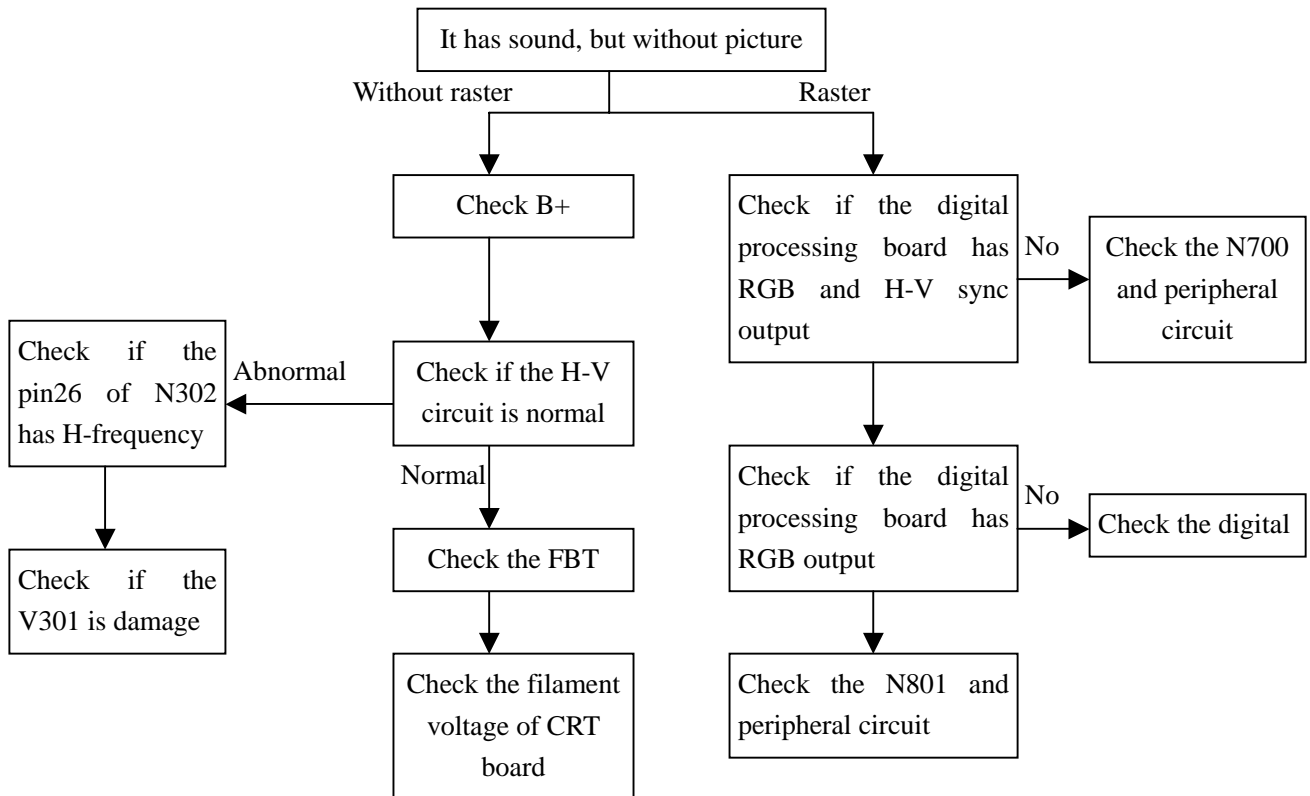

Schematic diagram

1

2

3

4

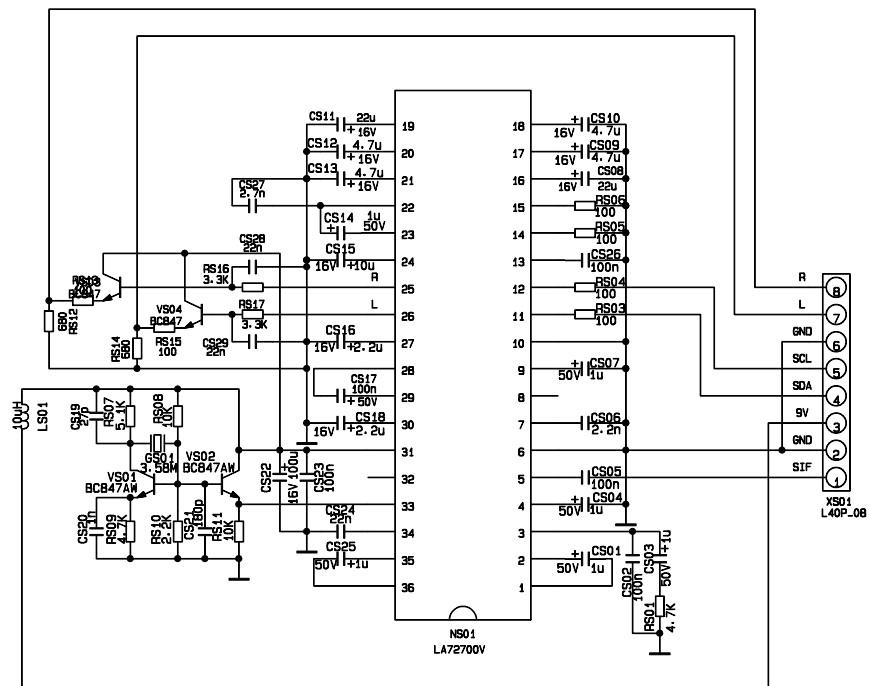

		名称	编号	
版次	更改单号		203-XX-01DL	
	更改记录	XX板电路图	版次	A1.0
拟制			第 1 页 共 1 页	
审核			厦门华侨电子股份有限公司	
标准化				
工艺				
批准				

版次	更改单号	名称	编号
更改记录		主板电路图	203-TJ27780-01DL
拟制			版次 A1.0
审核			第 1 页 共 1 页
标准化			厦门华侨电子股份有限公司
工艺			
批准			

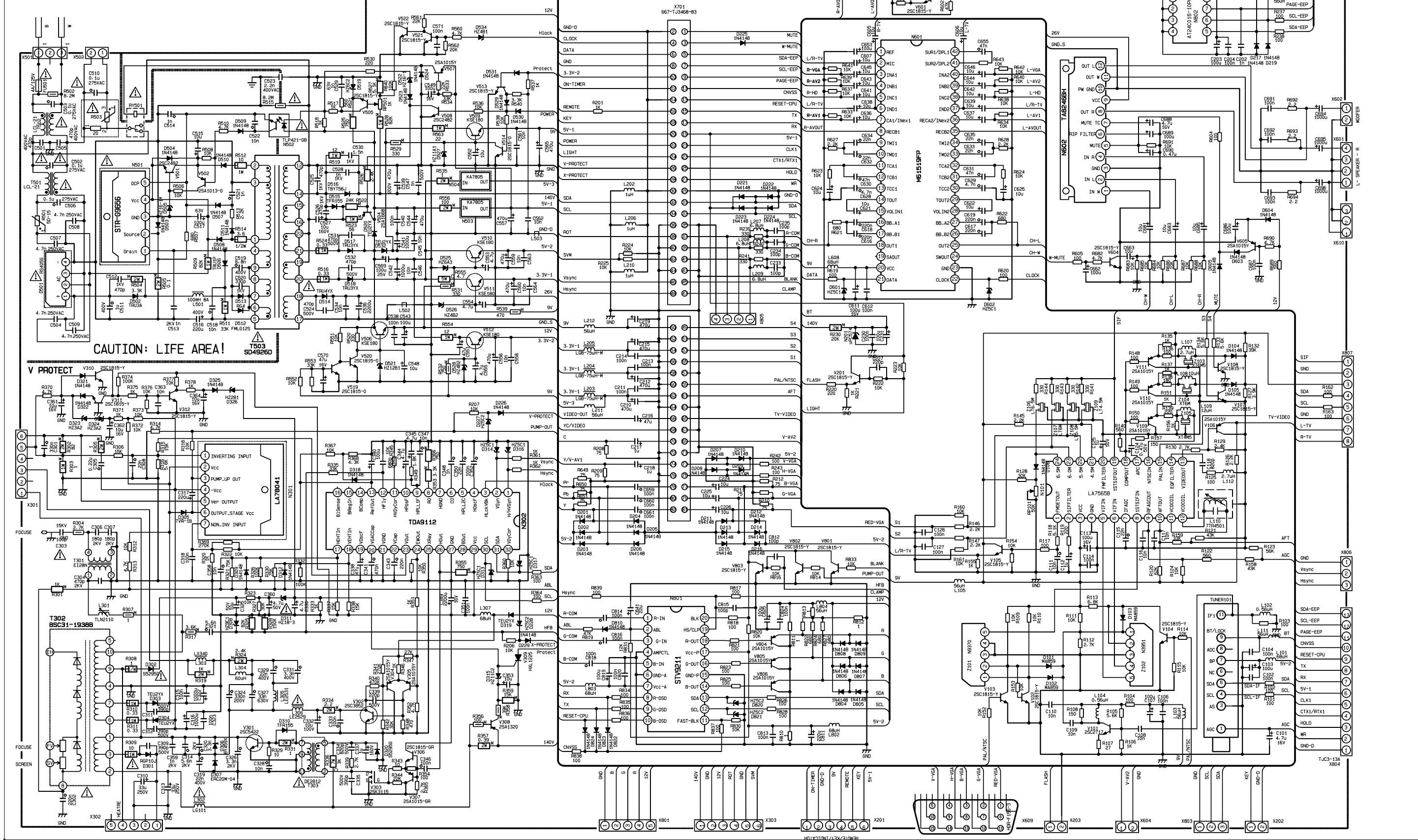

CAUTION: LIFE AREA!

TJ27780-01DL

SVP-EX [208]

(1 of 2)

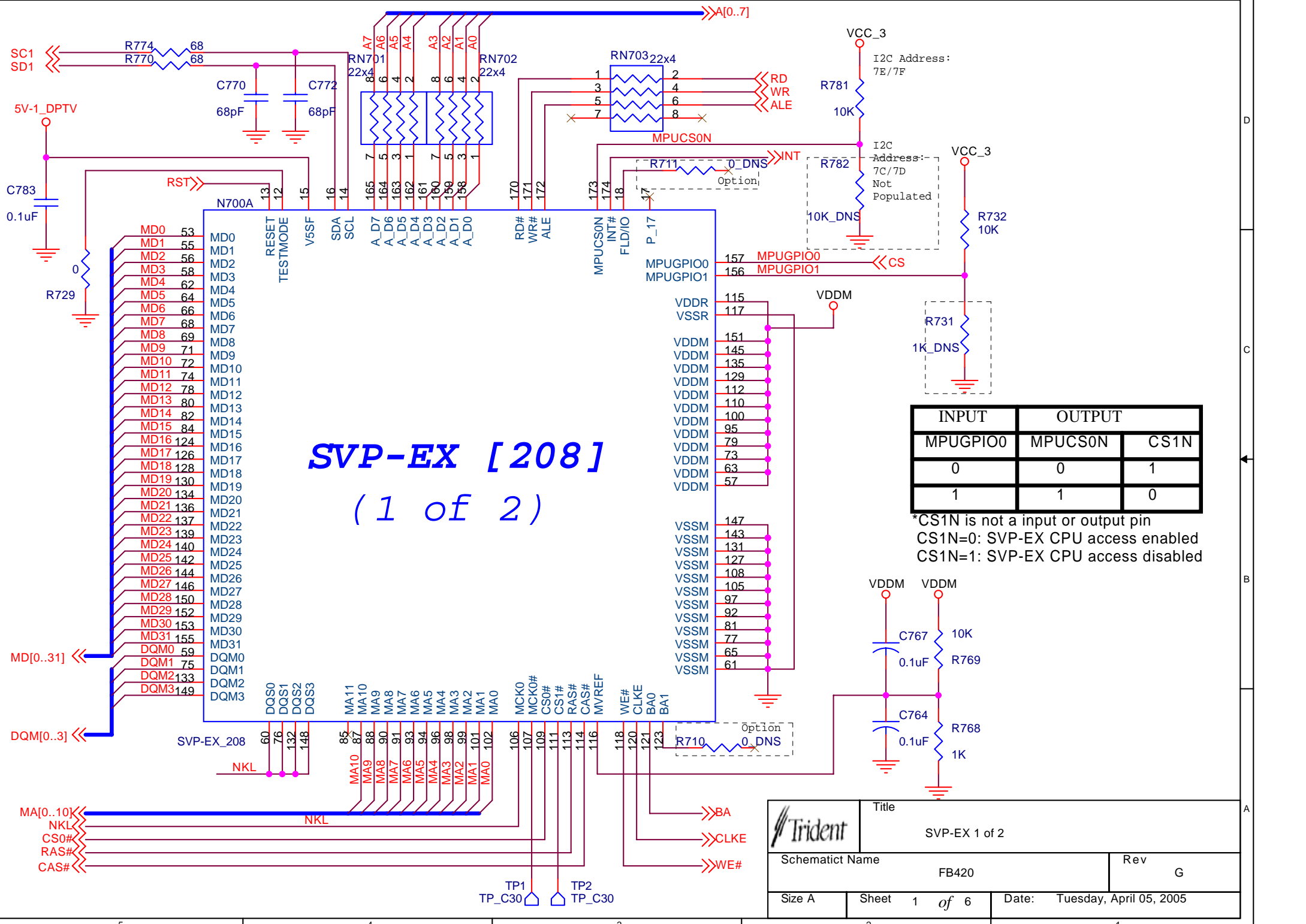

INPUT	OUTPUT	
MPUGPIO0	MPUCS0N	CS1N
0	0	1
1	1	0

*CS1N is not a input or output pin
 CS1N=0: SVP-EX CPU access enabled
 CS1N=1: SVP-EX CPU access disabled

	Title	
	SVP-EX 1 of 2	
Schematic Name	FB420	Rev
Size A	Sheet 1 of 6	G
Date: Tuesday, April 05, 2005		

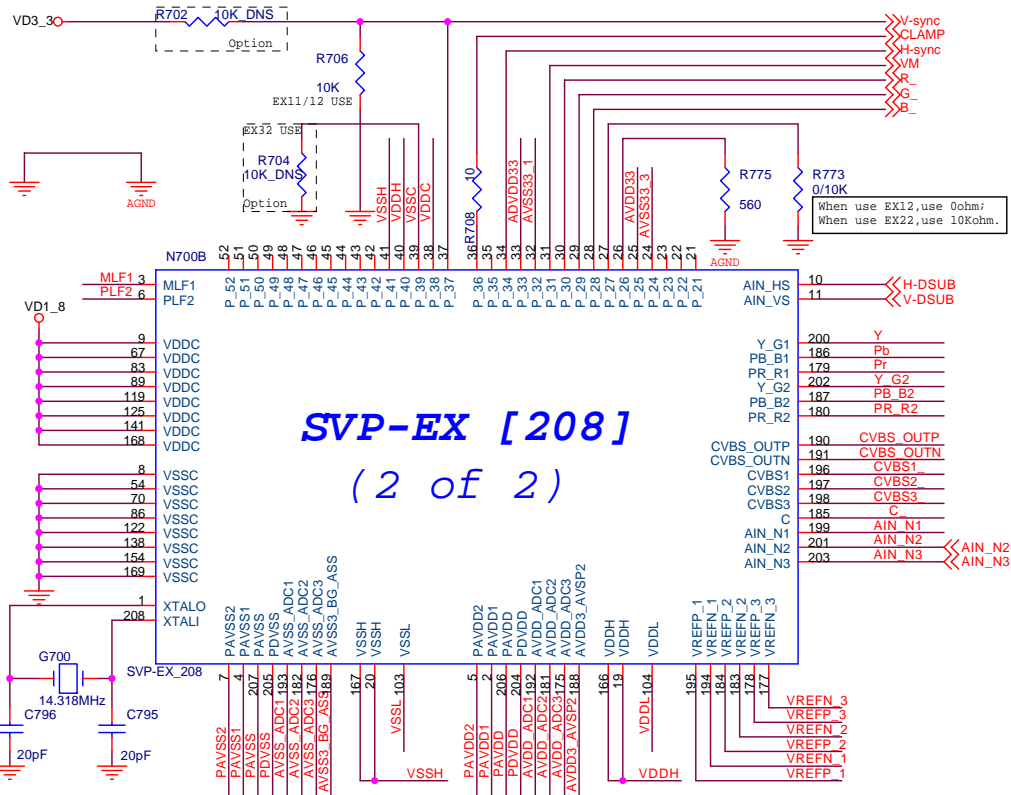

SVP-EX [208]
(2 of 2)

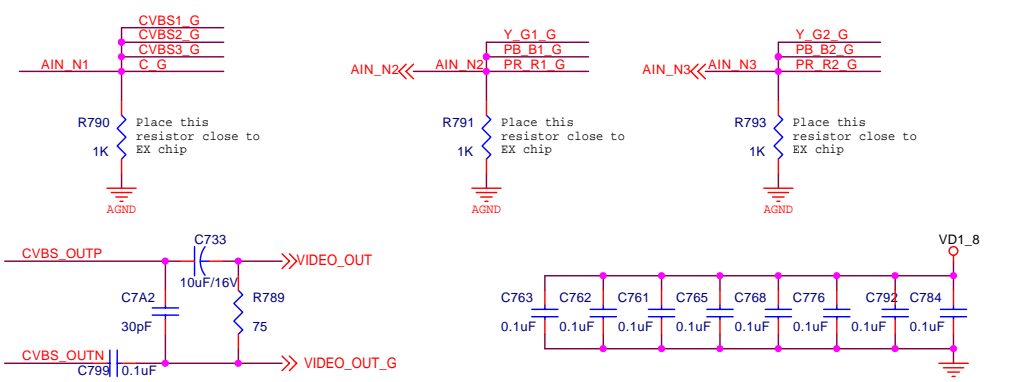
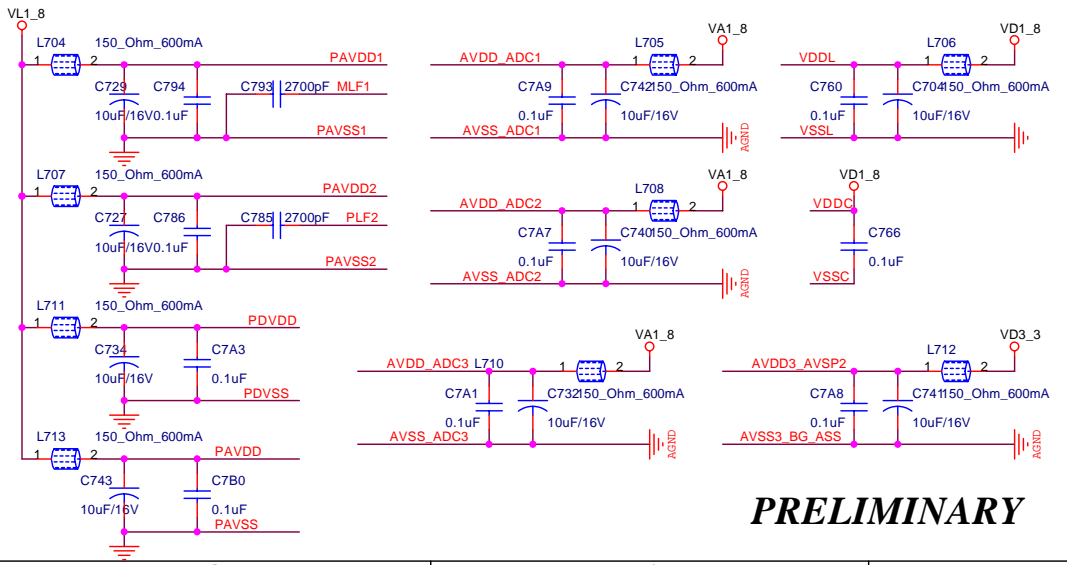
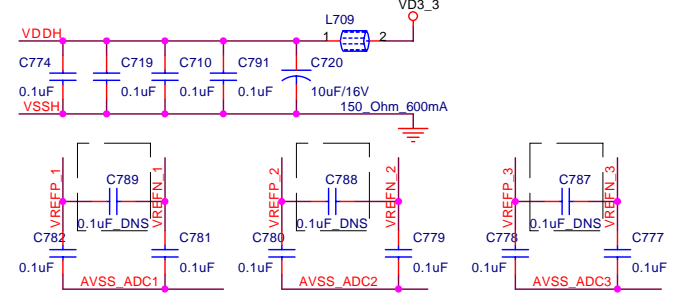
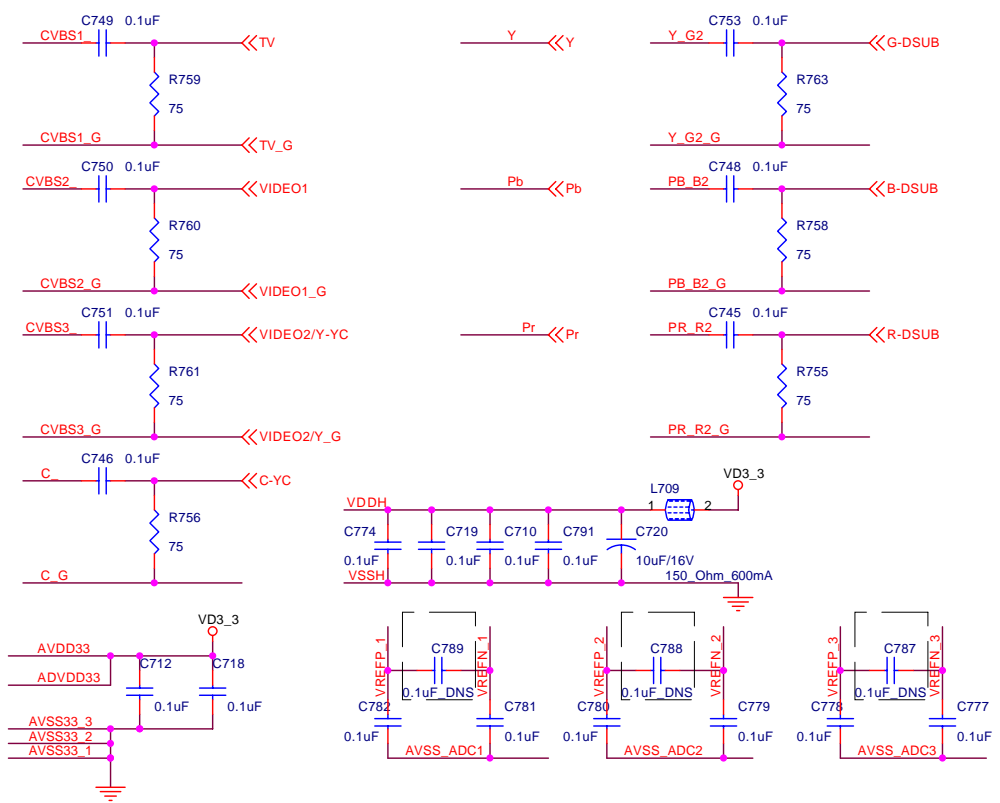

PRELIMINARY

		Title	
		SVP-EX 2 of 2	
Schematic Name		FB420	Rev G
Size B	Sheet 2 of 6	Date:	Tuesday, April 05, 2005

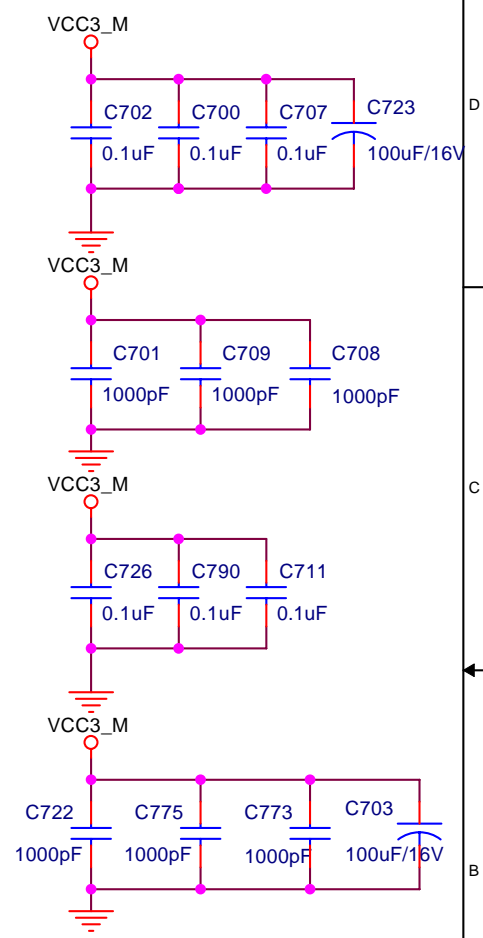
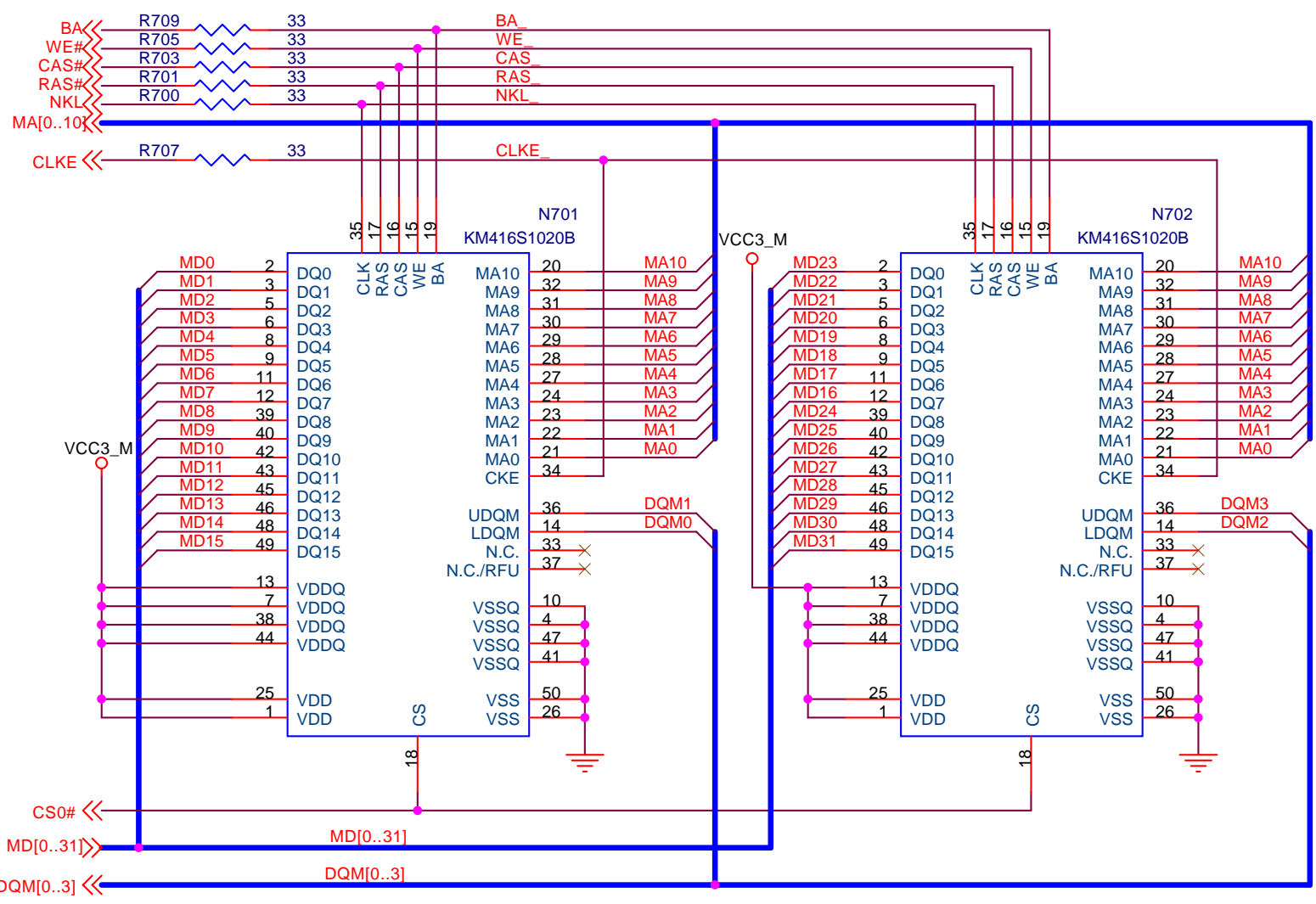

SDRAM
DECOUPLING
CAPACITORS

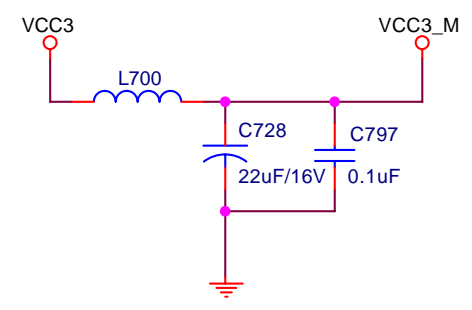

	Title	
	SDRAM 1MX16	
	Schematic Name	Rev
	FB420	G
Size A	Sheet 3 of 6	Date: Thursday, March 31, 2005

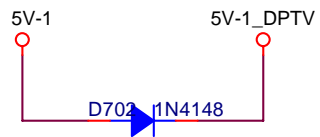
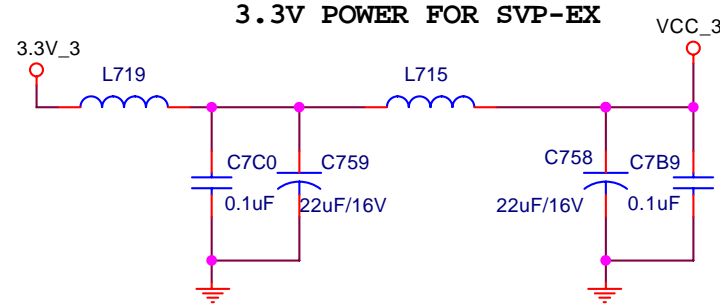
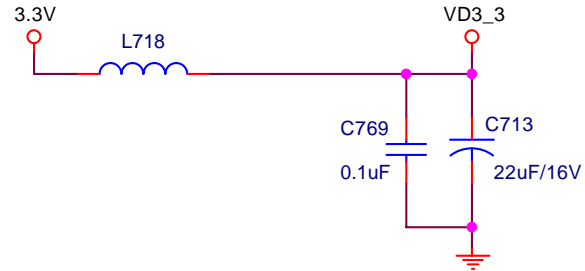
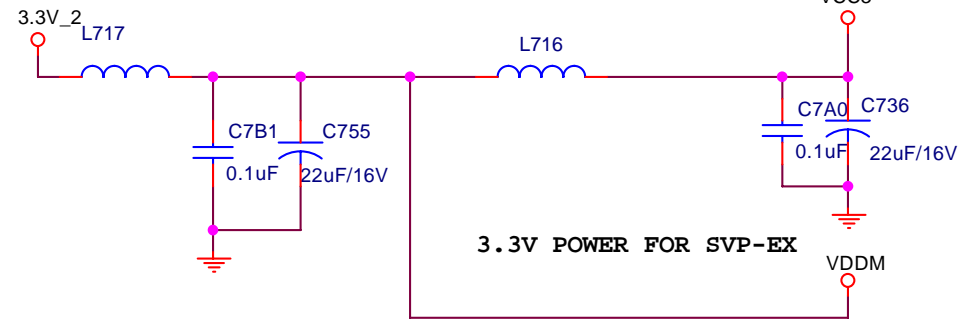
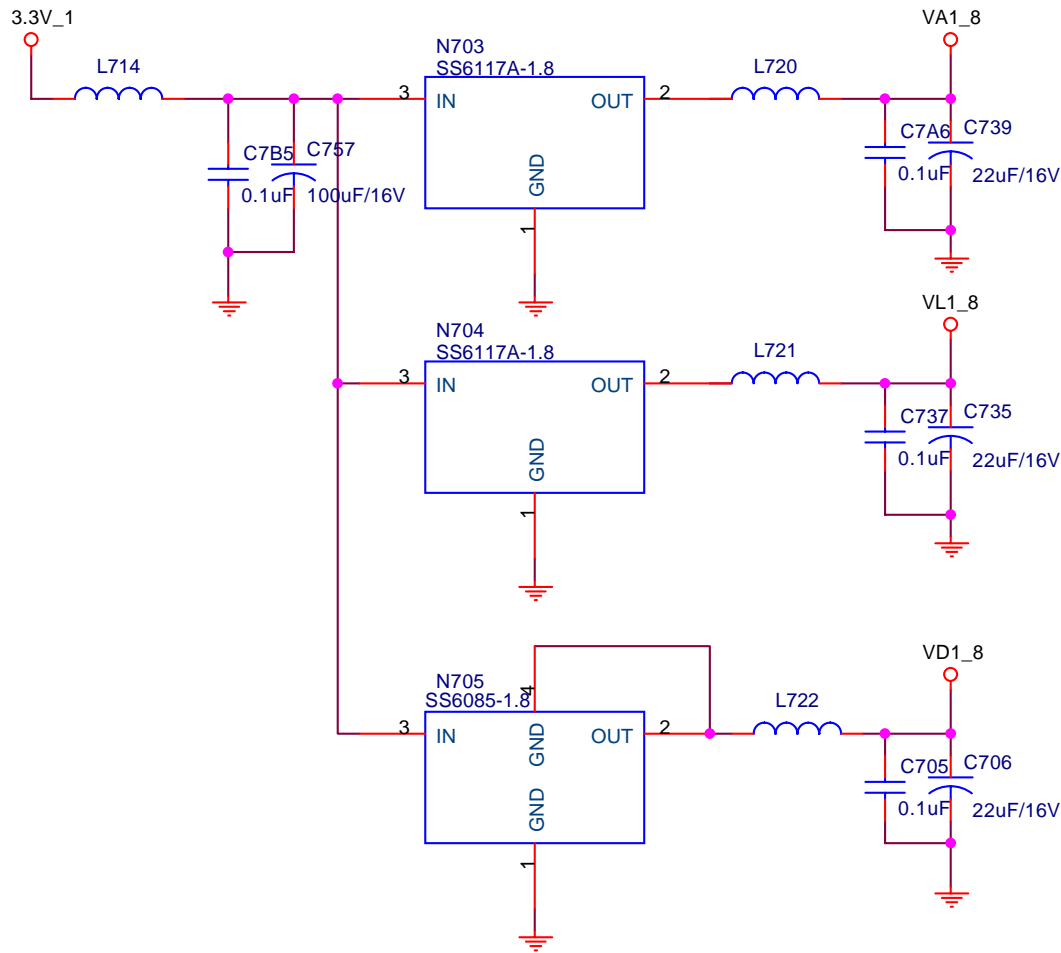

	Title POWER	
	Schematic Name FB420	Rev G
	Size A	Sheet 4 of 6
Date: Tuesday, April 05, 2005		

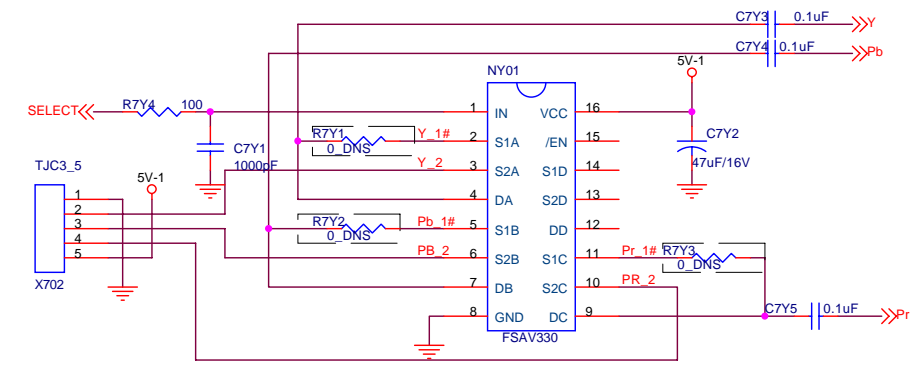
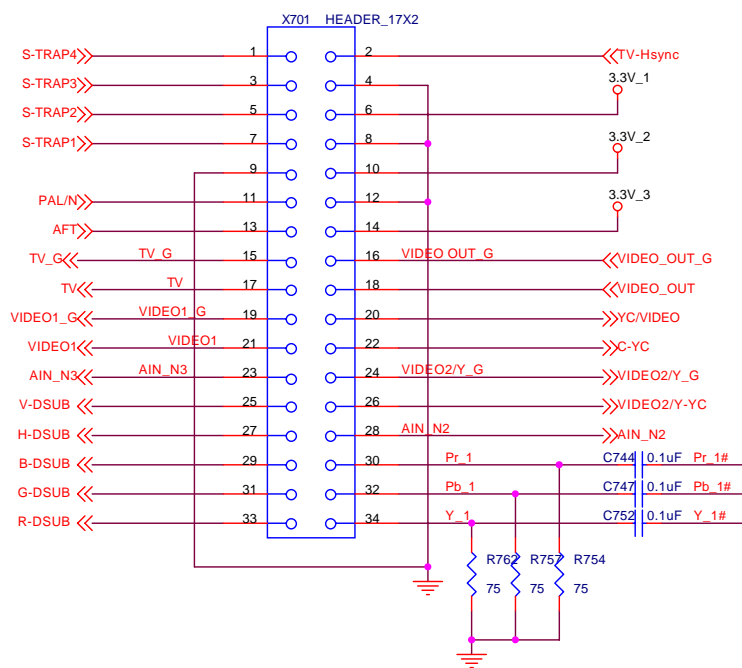
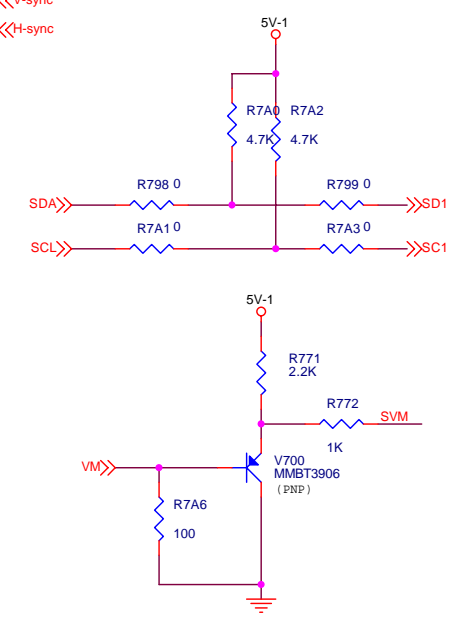
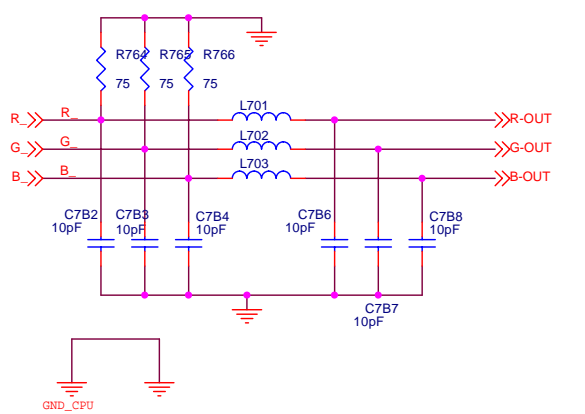
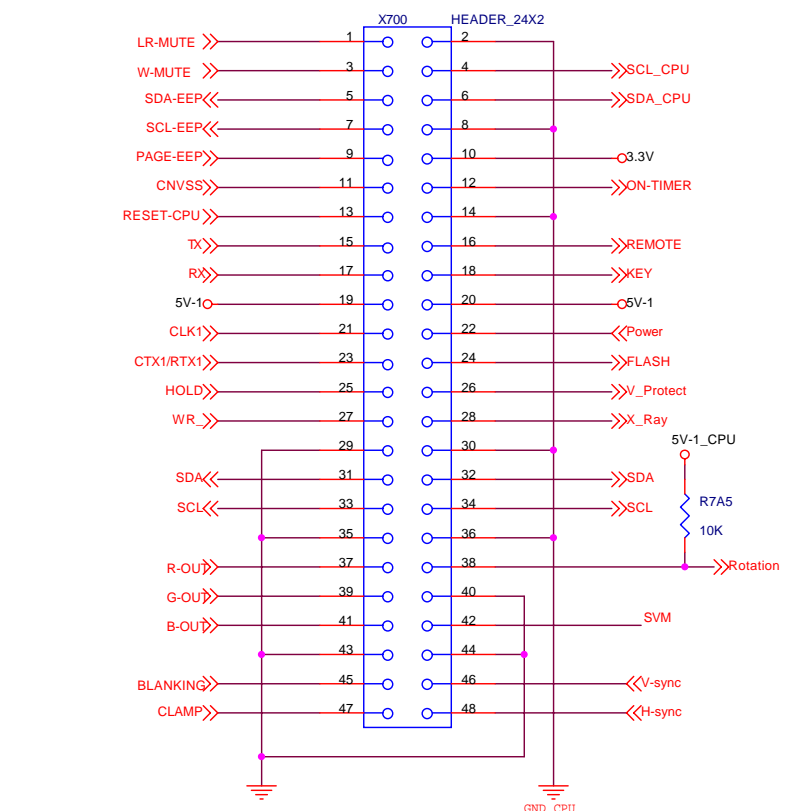

		Title	
Schematic Name		INTERFACE CONNECTOR	
FB420		Rev G	
Size B	Sheet 5 of 6	Date: Wednesday, April 06, 2005	

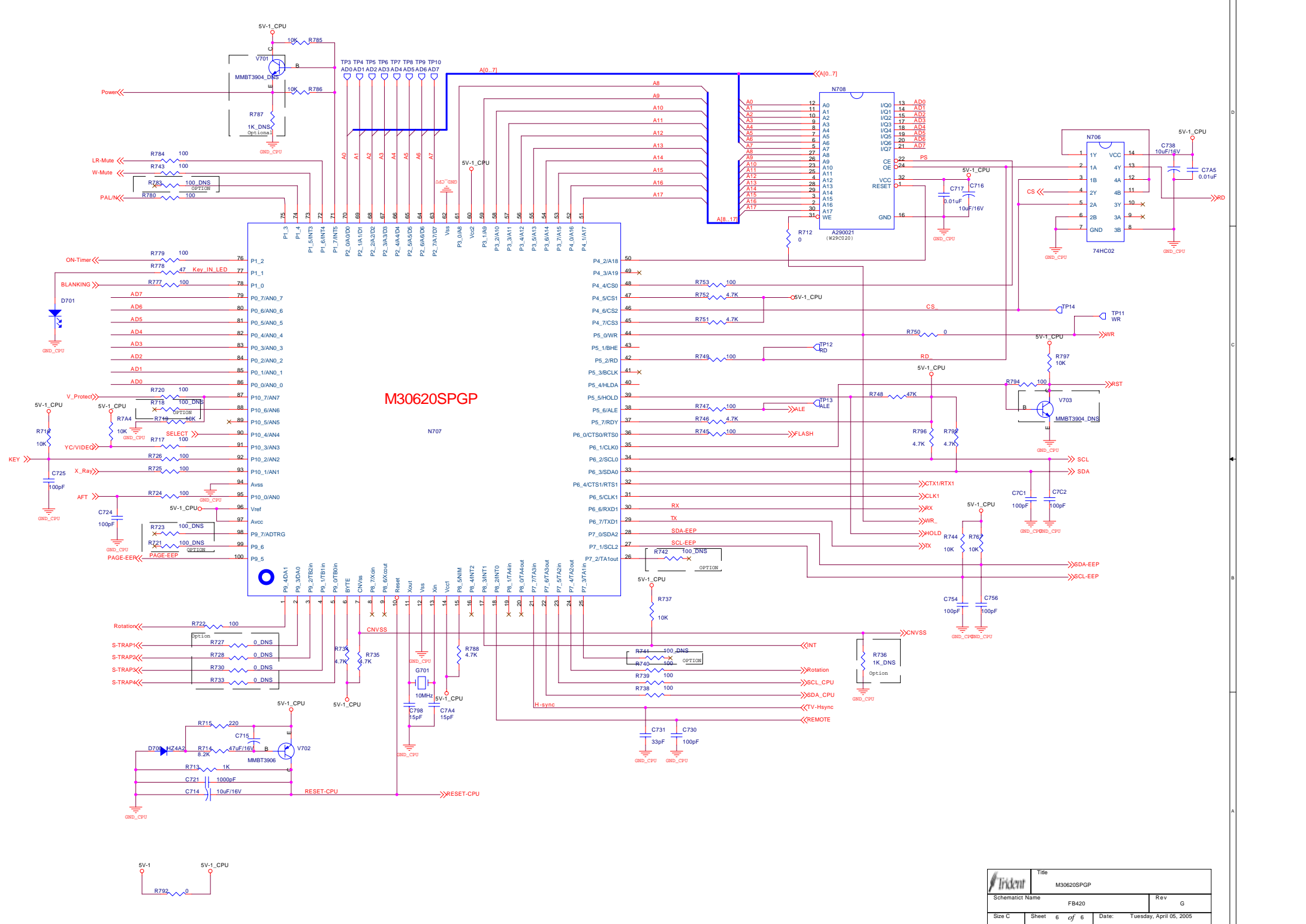

M30620SPGP

Title		M30620SPGP	
Schematic Name		FB420	
Rev		G	
Size C	Sheet 6 of 6	Date:	Tuesday, April 06, 2005

603-TJ27680-01
603-TJ27780-01
603-TJ3060-01
Ver.1.0