

Thermal switch circuit

Design Goals

Temperature Switching Point	Output		Supply		
	$V_o = \text{HIGH}$	$V_o = \text{LOW}$	V_{cc}	V_{ee}	V_{pu}
T_{sp}	$V_o = \text{HIGH}$	$V_o = \text{LOW}$	V_{cc}	V_{ee}	V_{pu}
100 °C	$T_A < T_{sp}$	$T_A > T_{sp}$	5V	0V	3.3V

Design Description

This thermal switch solution will signal low (to a GPIO pin) when a certain temperature is exceeded thus alerting when conditions are no longer optimal or device-safe. This circuit incorporates an NTC thermistor with a comparator configured in a non-inverting fashion.

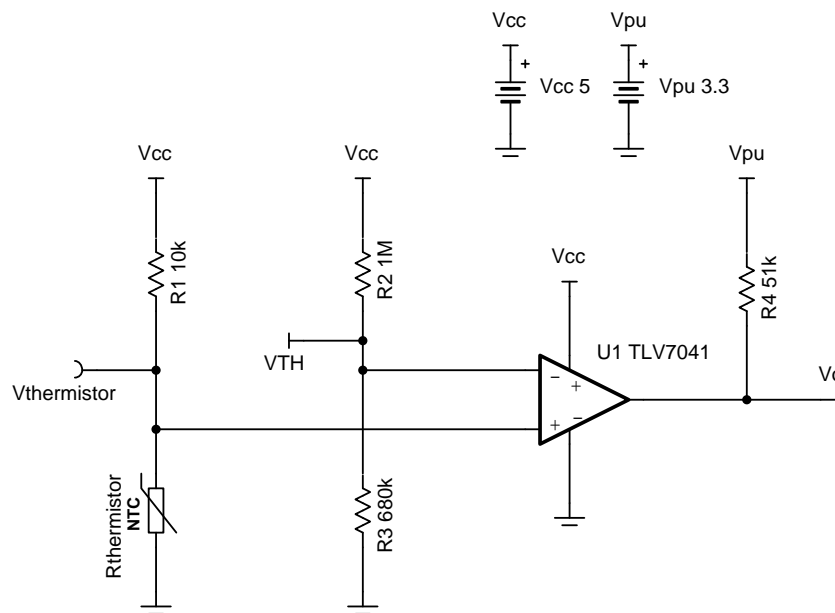

Design Notes

1. The resistance of an NTC thermistor drops as temperature increases.
2. The TLV7041 has an open drain output, so a pull-up resistor is required.
3. Configurations where the thermistor is placed near the high side of the divider can be done; however, the comparator will have to be used in an inverting fashion to still have the output switch low.
4. To exercise good practice, a positive feedback resistor should be placed to add external hysteresis (for simplicity, it is not done in this example).

Design Steps

1. Select an NTC thermistor, preferably one with a high nominal resistance, R_0 , (resistance value when ambient temperature, T_A , is 25 °C) since the TLV7041 has a very low input bias current. This will help lower power consumption, thus reducing the likelihood of reading a slightly higher temperature due to thermal dissipation in the thermistor. The thermistor chosen has its R_0 and its material constant, β , listed below.

$$R_0 = 100\text{k}\Omega$$

$$\beta = 3977\text{K}$$

2. Select R_1 . For high temperature switching points, R_1 should be 10 times smaller than the nominal resistance of the thermistor. This causes a larger voltage difference per temperature change around the temperature switching point, which helps guarantee the output will switch at the desired temperature value.

$$R_1 = \frac{R_0}{10}$$

$$R_1 = \frac{100\text{k}\Omega}{10} = 10\text{k}\Omega \quad (\text{Standard Value})$$

3. Select R_2 . Again, this can be a high resistance value.

$$R_2 = 1\text{M}\Omega \quad (\text{Standard Value})$$

4. Solve for the resistance of the thermistor, $R_{\text{thermistor}}$, at the desired temperature switching point. Using the β formula is an effective approximation for thermistor resistance across the temperature range of -20 °C to 120 °C. Alternatively, the Steinhart-Hart equation can be used, but several device-specific constants must be provided by the thermistor vendor. Note that temperature values are in Kelvin. Here $T_0 = 25 \text{ °C} = 298.15\text{K}$.

$$R_{\text{thermistor}}(T_{\text{sp}}) = R_0 \times e^{\beta \times \left(\frac{1}{T_{\text{sp}}} - \frac{1}{T_0} \right)}$$

$$R_{\text{thermistor}}(100\text{°C}) = 100\text{k}\Omega \times e^{3977\text{K} \times \left(\frac{1}{373.15\text{K}} - \frac{1}{298.15\text{K}} \right)}$$

$$R_{\text{thermistor}}(100\text{°C}) = 6.85 \text{ k}\Omega$$

5. Solve for $V_{\text{thermistor}}$ at T_{sp} .

$$V_{\text{thermistor}}(T_{\text{sp}}) = V_{\text{CC}} \times \frac{R_{\text{thermistor}}(T_{\text{sp}})}{R_1 + R_{\text{thermistor}}(T_{\text{sp}})}$$

$$V_{\text{thermistor}}(100\text{°C}) = 5\text{V} \times \frac{6.85\text{k}\Omega}{10\text{k}\Omega + 6.85\text{k}\Omega} = 2.03\text{V}$$

6. Solve for R_3 with the threshold voltage, V_{TH} , equal to $V_{\text{thermistor}}$. This ensures that $V_{\text{thermistor}}$ will always be larger than V_{TH} until the temperature switching point is exceeded.

$$R_3 = \frac{R_2 \times V_{\text{TH}}}{V_{\text{CC}} - V_{\text{TH}}}$$

$$R_3 = \frac{1\text{M}\Omega \times 2.03\text{V}}{5\text{V} - 2.03\text{V}} = 685\text{k}\Omega$$

$$R_3 = 680\text{k}\Omega \quad (\text{Standard Value})$$

7. Select an appropriate pull up resistor, R_4 . Here, $V_{\text{pu}} = 3.3\text{V}$ (digital high for a microcontroller).

$$R_4 = 51\text{k}\Omega \quad (\text{Standard Value})$$

Design Simulations

DC Temperature Simulation Results

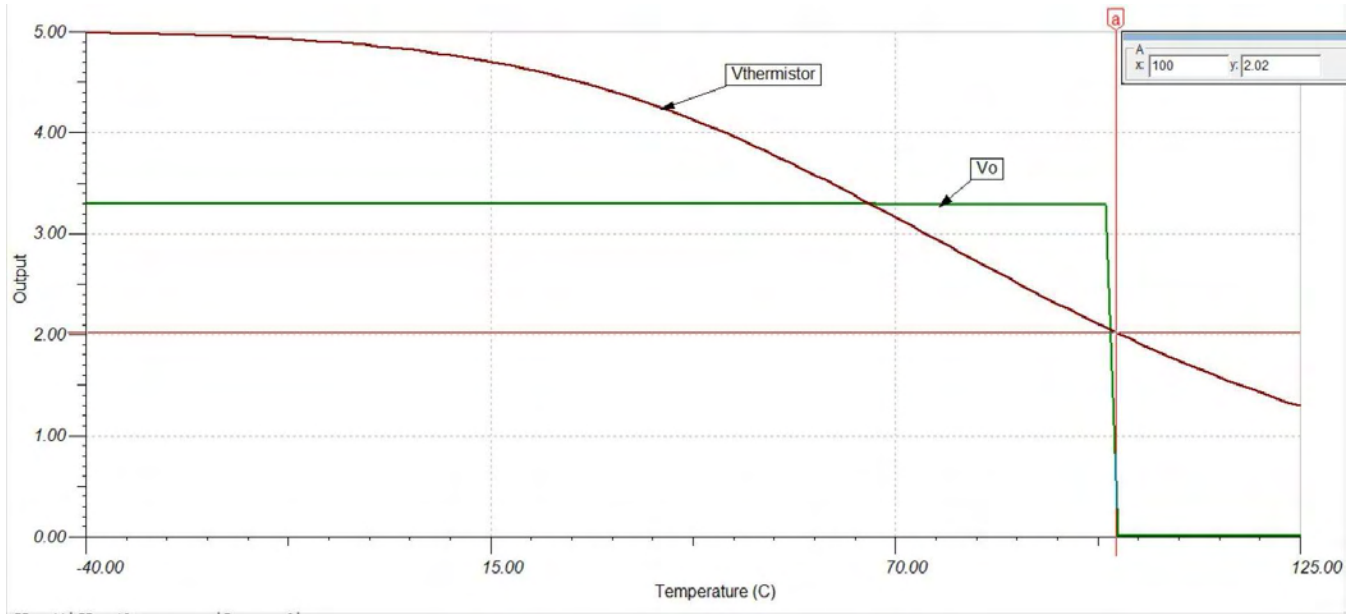

Design References

See [Analog Engineer's Circuit Cookbooks](#) for TI's comprehensive circuit library.

See Circuit SPICE Simulation File SLVMCS1, www.ti.com/lit/zip/slvms1.

Design Featured Comparator

TLV7041	
Output Type	Open-Drain
V_{cc}	1.6V to 6.5V
V_{inCM}	Rail-to-rail
V_{os}	$\pm 100\mu V$
V_{HYS}	7mV
I_q	335nA/Ch
t_{pd}	3 μs
#Channels	1
www.ti.com/product/tlv7041	

Design Alternate Comparator

TLV1701	
Output Type	Open-Collector
V_{cc}	2.2V to 36V
V_{inCM}	Rail-to-rail
V_{os}	$\pm 500\mu V$
V_{HYS}	N/A
I_q	55 μA /Ch
t_{pd}	560ns
#Channels	1, 2, 4
www.ti.com/product/tlv1701	
www.ti.com/product/tlv1701-q1	