

# Compact 160 Meter Transmitting Loop Antenna

*You don't need to move to a new QTH!*

by Richard Q. Marris G2BZQ

The 160 meter band (1800-2000 kHz) is beyond the reach of a high percentage of transmitting amateurs. Yet, this band can be most enjoyable, usually with a very high standard of operating. But—there are problems!

The fact is that most TXers have near-impossible antenna problems. These are: 1) a lack of sufficiently large real estate to erect an antenna; 2) local antenna restrictions regarding putting up a large antenna; 3) the impossibility of installing the necessary efficient ground system; 4) the apartment dweller's lack of antenna space; or 5) the "no TX antennas here" syndrome. Probably over half of the licensed amateurs live in apartments, or have very restricted space for a large outdoor antenna, or face "rules and regulations," or other restrictions.

The answer to "getting on the air" on 160 is a small indoor vertical multi-turn tuned loop which, though small in size, is difficult to load and match to the TX. If a balanced configuration is used, it will operate without a ground connection. Properly designed, such a loop will give yeoman service. It obviously will not compete with a 160 meter dipole or a Beverage, however, which few have space for.

The size of the loop will be dictated by the domestic space available, the amount of wire required (in turns!), and the absolute necessity to finish up with a design with *an exact number of complete turns*, i.e. no half turns, quarter turns or other part turns. Strangely enough, the proximity effect is far less critical than on 80 meter or higher band loops.

The circuit is simple but novel (see Figure 1), and shows six square loop turns resonated by variable capacitor C1 (with C2 in

series), and loaded with coil L2, with a 50-ohm impedance matching tapping point. An optional ground connection is shown but, unless a really good radial ground is available, it is better not to use one at all at the loop. I use a water pipe as a ground, connected to the TX/RX input socket, and not the loop. The loop has been used

could stand the loop on the floor of a loft, with a conventional remote control turning mechanism.

C1 is a robust 150 pF variable capacitor, which was available, with a 150 pF high voltage (2KV) capacitor (C2) in series. Depending on availability, C1 and C2 could be replaced with a single 75 pF variable.

## Construction

The main frame (Figure 3) is made of 1-1/4" x 3/8"-thick seasoned timber. This is assembled, as shown, to give a 36" x 36" square frame, reinforced with wood corner blocks and glued together. The whole frame is rubbed down with fine glass paper, and finished with teak wood stain. Onto this frame are wound six turns of 16/0.2mm PVC-covered wire (o/d = 1.8mm). This wire is rated as 3 amps at 1000 volts RMS. The wire turns are equi-spaced to approximately 1/4" apart, from center conductor to center conductor. The loop turns are terminated as shown in Figures 3 and 4C.

The tuning/matching unit (C1 + C2 + L2) is built into a gray (see the safety note at the end of the Parts List) plastic box 7-1/4" x 3/8" x 2-3/8" (see Figures 4A and B). The box is bolted (with the lid to the rear) to a solid wood base 12" x 8" x 1/2".

L2 is a self-supporting coil consisting of 30 slightly-spaced 1" diameter turns of 16-gauge tinned copper wire. The top end of L2 is soldered to a thin brass bolt through the box top, and hangs down, so that the bottom end is soldered to a thin brass strip used to connect the frame of C1 to the outer of the coaxial socket. The socket center conductor is tapped, via a short lead, to L2 (described later in this article).

The loop frame/winding (see Figure 3) is bolted to the top of the plastic box, using nylon bolts/nuts/washers (see Figure 4C) which

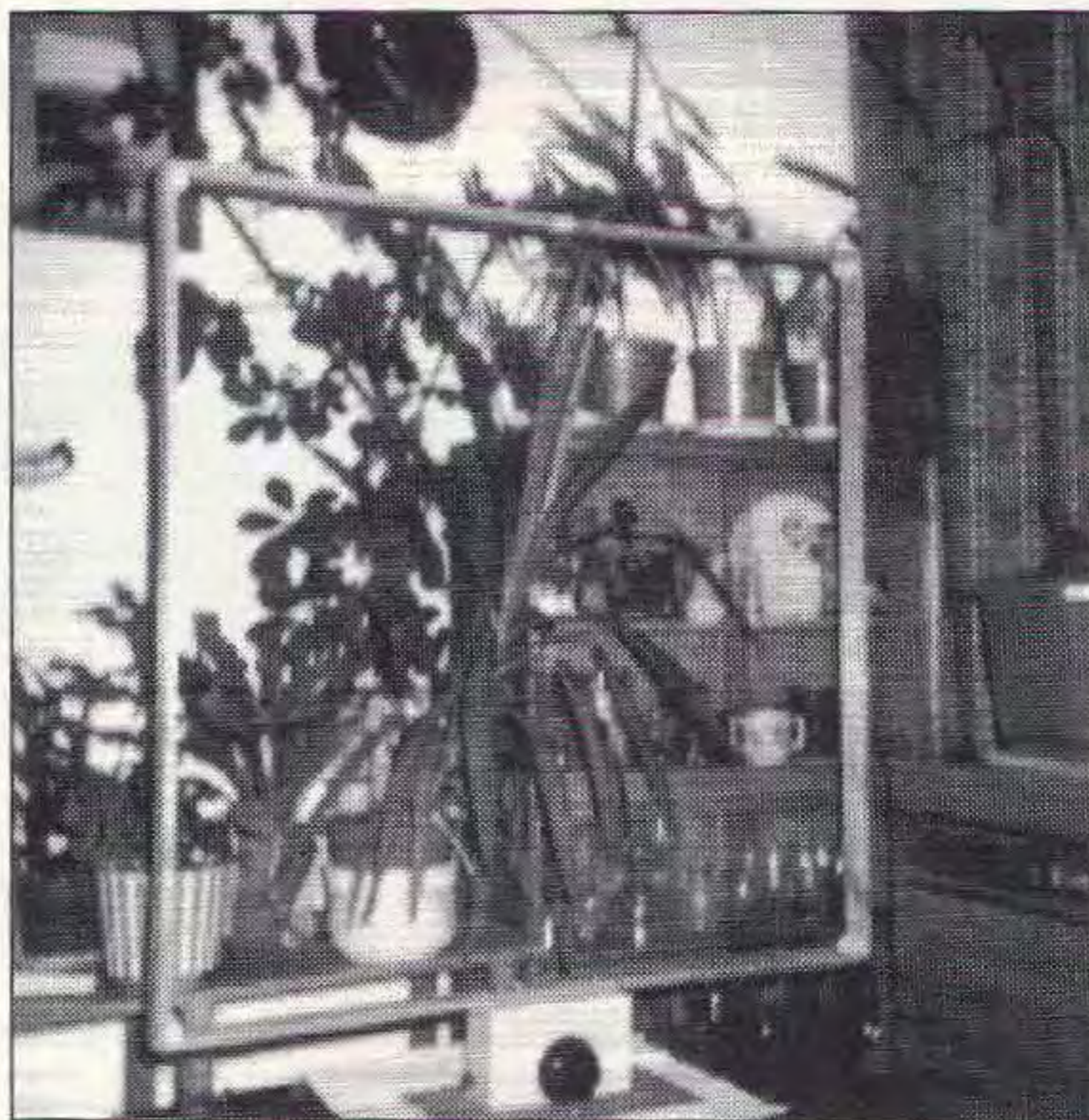

Photo A. The finished 160 meter loop.

with about 7 watts CW.

Figure 2 shows the neat profile of the loop. It consists of six wire turns wound around a 36" x 36" timber frame, mounted on a plastic box containing the resonating/loading/matching circuitry.

At this QTH the loop stands on a table alongside the operating position, with the tuning knob (C1) within easy reach. Operating is made easier with a large instrument knob. The room is about 20 feet above ground level. No doubt the more ingenious

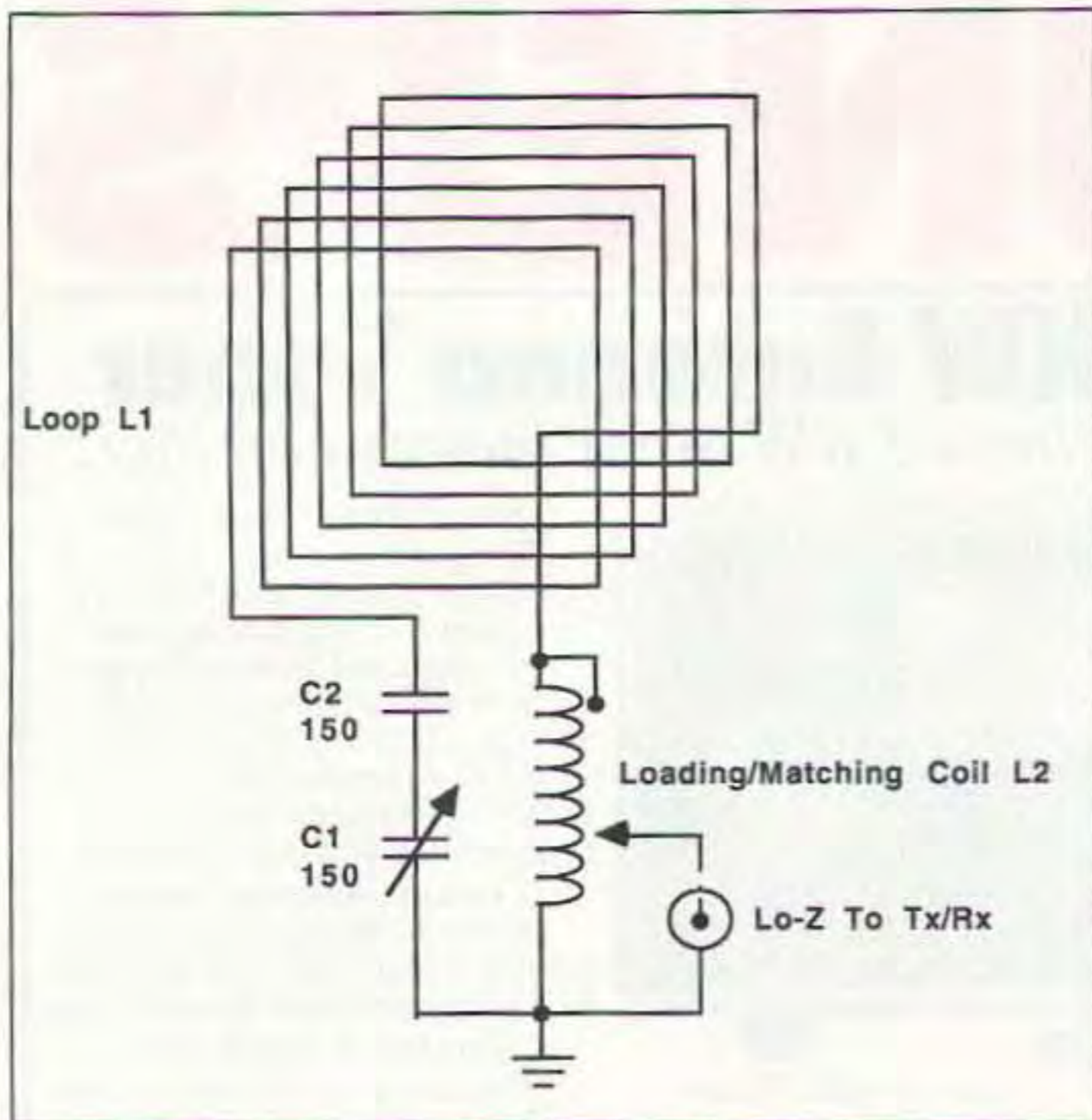

Figure 1. The circuit.

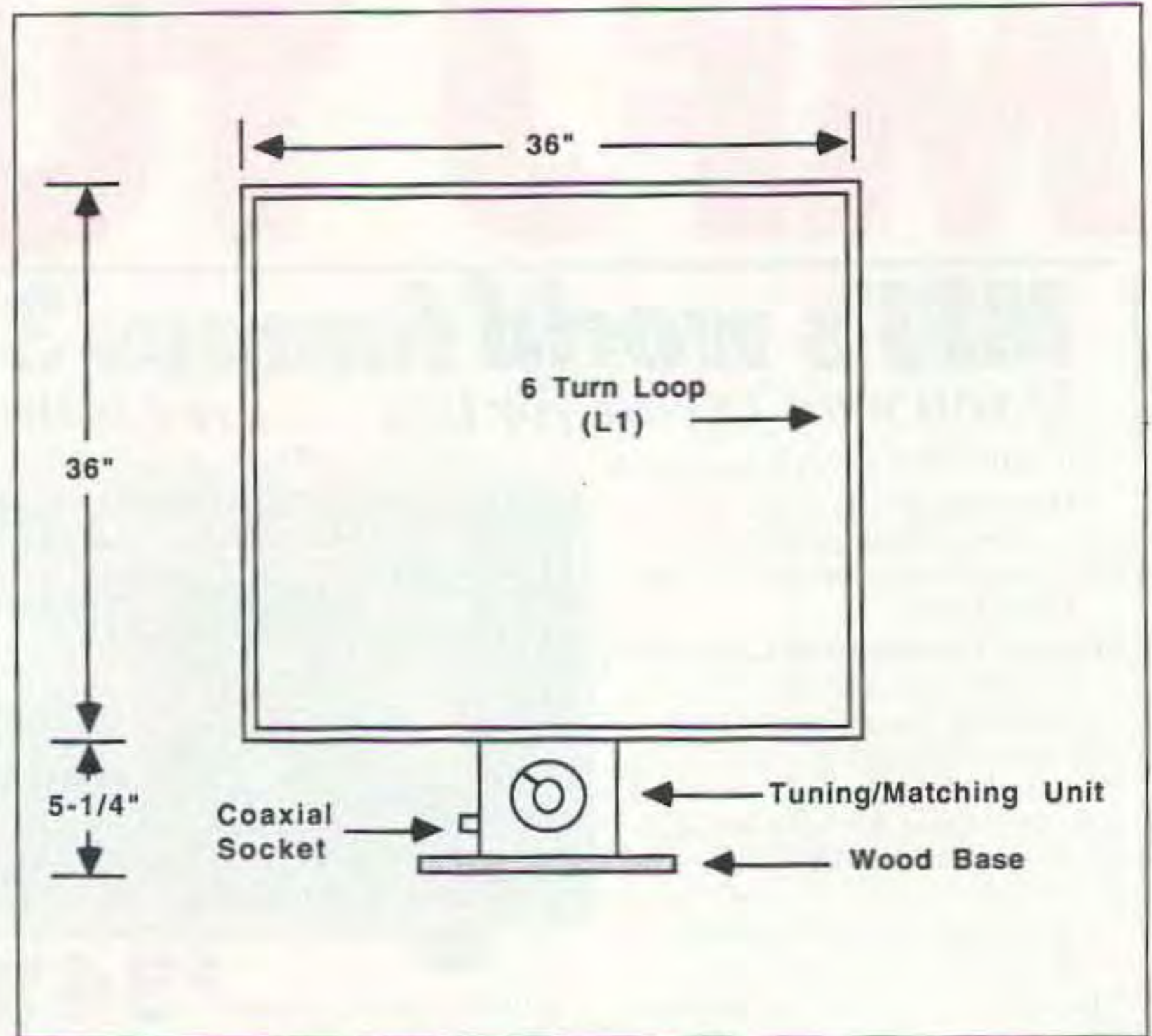

Figure 2. Loop profile.

pass through between turns three and four of the winding. Do not use metal bolts as these may partially RF short adjacent turns.

The loop is connected to the TX/RX with a short length (5 feet) of RG58 feedline.

#### Getting On The Air

The top tap on L2 (from end of L1) will

determine the frequency range. For maximum efficiency, C1 should be set as near zero pF capacity as possible, at the HF end of the band (i.e. 2000 kHz).

The impedance matching tap from the coaxial socket is connected for the best impedance matching for 50 ohms. On the prototype this was at 19 turns up from the

bottom of L2, and this should be used initially while the loop frequency range is adjusted.

Checking the frequency range on a receiver turned to 2030 kHz, try shorting out turns, from the top of L2. On the prototype it was necessary to short out the top two turns, to resonate the loop, on the RX, at 2030 kHz

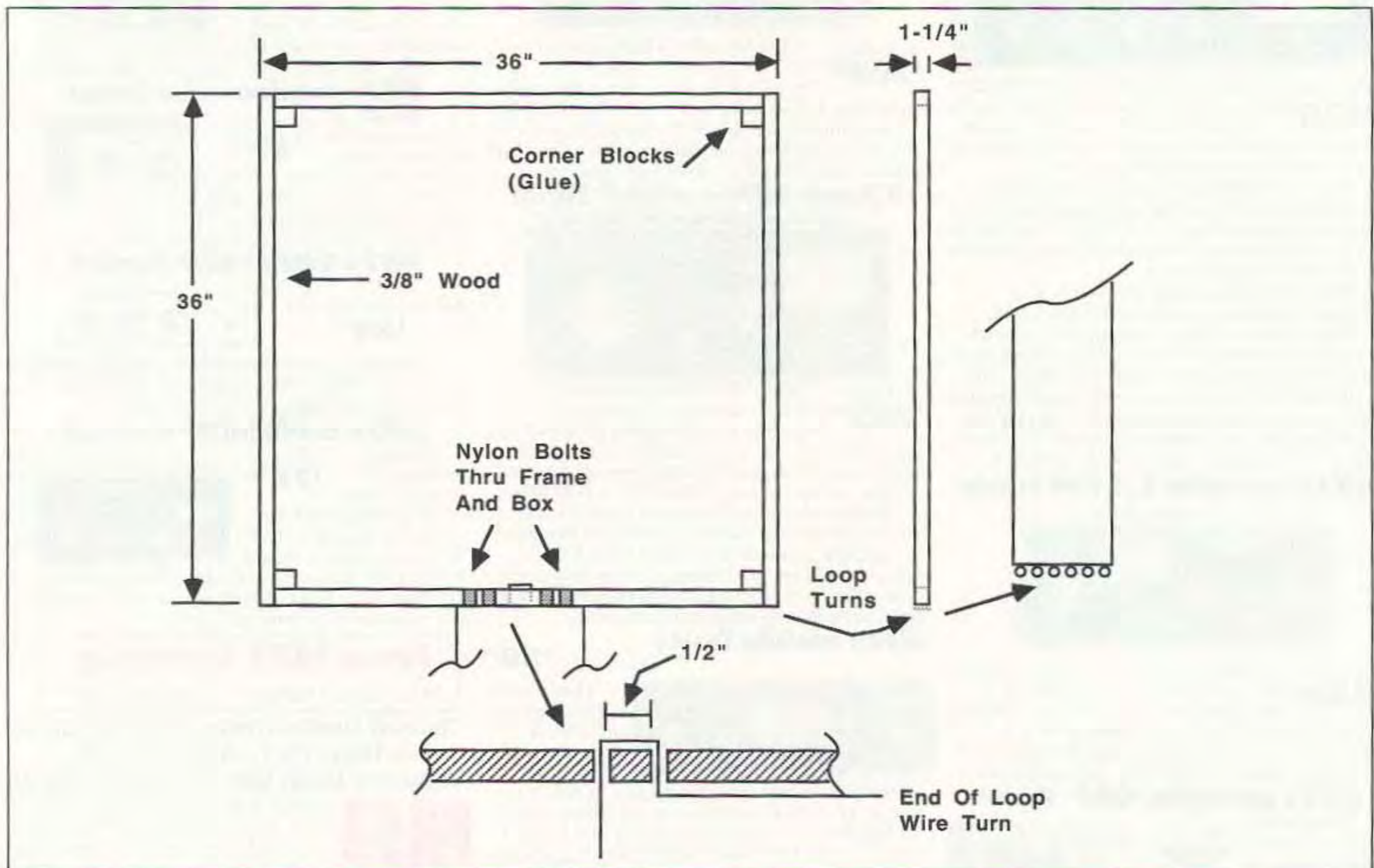

Figure 3. Main frame and loop winding.

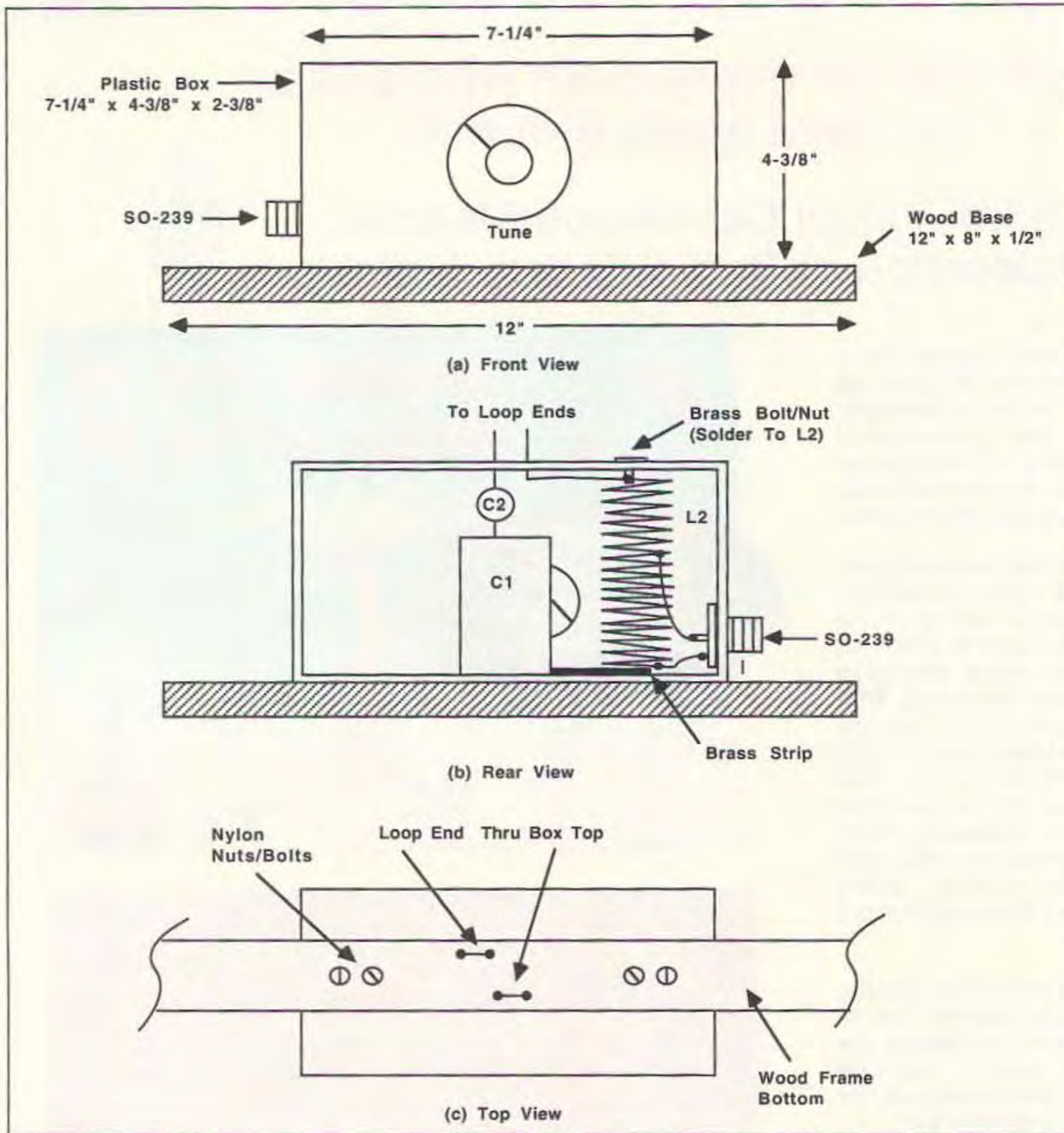

Figure 4. Tuning/matching unit.

with zero capacity on C1. It follows that to resonate at the 2000 kHz HF band edge, it will require a small amount of capacity on C1. The loop will now resonate throughout the band by adjusting C1, with no further coil adjustment necessary.

Apply a few watts to the loop and it should load quite easily at the TX frequency. Due to the possibility of minor differences in individual construction, the impedance matching tap, on L2, should be tried +/- a little to obtain best matching.

The loop is now ready to try "on-the-air." The usable bandwidth, on a fixed setting of C1, is about 11 kHz on the prototype. The advantage of this narrow bandwidth is twofold: The loop acts as a comparatively narrow bandwidth band-pass filter eliminating harmonics and TVI; it also reduces ambient noise and general man-made interference on the receiver. The loop has been used with about 7 watts CW with the TX having a Pi-output circuit.

Remember: TX frequency = loop resonant frequency = RX frequency. Have fun! 73

#### Parts List

Qty.	Part
1	Variable capacitor (C1) 150 pF wide space receiving type (see text)
1	Capacitor (C2) 150 pF silver mica or ceramic disc (2 kV)
1	2 oz. reel of 16 gauge tinned copper wire.
1	Coaxial socket
Loop wire	16/0.2mm high temperature PVC wire (o.d.= 1.8mm), 3 amps at 1000 volts RMS
1	Plastic box ("not black) 7-1/4" x 4-3/8" x 2-3/8" minimum
2	Lengths of dry seasoned timber 6'0" x 1-1/4" x 3/8"
1	Small tin of teak wood dye and glue
1	Baseboard 12" x 8" x 1/2" timber

\*Safety—Plastic Boxes: It has been suggested that some *black* molded plastic boxes are made using recycled plastic, and that carbon black is used for black coloring (obviously not good at RF). It has been impossible to check this as many boxes are molded in Taiwan, etc., so: **Safety First.**

**TigerTail™**

Range Extender for 2 meter Handhelds

- Boosts Signal from Flex & 1/4 wave Antennas
- Lowers Radiation Angle
- Improves both Receive and Transmit Performance
- Raises Low Power Performance
- Saves your Battery Pack

- Easy to Use
- Unobtrusive
- Easily Concealed
- Snaps on Handheld
- Weighs only 1.3 oz.
- Adds No Bulk or Height

AntennasWest  
Box 30062-S, Provo, UT 84605 1-800-926-7373

Order Hotline **7<sup>95</sup>**

See and Hear the Difference

CIRCLE 107 ON READER SERVICE CARD

THIS MONTH'S GOODIE FROM THE CANDY STORE

RDC YAESU FT-416/25B Under \$256.00 less applicable coupon

Similar Savings on AEA, Icom, Astron, Yaesu, Cushcraft, Alinco, Etc. All L.T.O.

Yaesu FT-73RTT \$240.00

Over 9039 Ham Items in Stock, all Prices, Cash FOB Preston. More Specials in HAM-ADS. Looking For Something Not Listed?? Call or Write. To save time and money, have the model number ready.

Call Today (208) 852-0830

ROSS DISTRIBUTING COMPANY  
78 S. State Street, Preston, Id. 83263  
Hours Tue.-Fri. 9-6 - 9-2 Mondays. Closed Sat. & Sun.

CIRCLE 254 ON READER SERVICE CARD

**HamWindows**

Your gateway to the world.

Software that combines the amateur radio with a personal computer.

HamWindows, Inc., 2121 E. Pacific Coast Hwy., Suite 120C  
Corona del Mar, CA 92625  
(714)729-4222 FAX (714)644-6277

CIRCLE 345 ON READER SERVICE CARD