

BUILD THE POOR MAN'S STROBE

Inexpensive circuitry allows timed, sequential flashes for multiple photographic exposures of moving subjects

BY IMRE GORGENYI*

STROBOSCOPIC photography, which exposes a single frame with light from a sequence of timed flashes, is an interesting way to capture a moving subject on film. The result is a series of still images that catch the subject in successive positions along its path, clearly suggesting motion. Stroboscopic photographs of a gymnast working out appear on the cover of this issue.

Unfortunately for shutterbugs, commercial equipment for stroboscopic photography is high in price. There are, however, circuits designed around readily available, inexpensive components that are easily built and will enable amateur photographers to experiment with the technique.

*Motorola Semiconductor Group

The Basic Poor Man's Strobe.

The circuit (Fig. 1) triggers a flash unit at a predetermined time after the receipt of a light pulse from another flash unit actuated by the camera's flash-sync output. A portion of the light from the camera-triggered flash falls on the window of phototransistor *Q1*, which briefly conducts. The resulting negative voltage pulse at the collector of *Q1* triggers the timing circuit comprising *C1*, *R2* through *R6*, and *Q2*.

At the end of the timing interval, whose duration is adjustable by means of potentiometer *R3*, *Q3* and its associated passive components generate a positive voltage pulse and couple it to the gate of *SCR1*. The SCR breaks into conduction and triggers

the flash unit whose sync contacts are connected to jack *J1*. Simultaneously, the timing circuit resets itself by means of *R6* to prepare for the next triggering light pulse. Power for the circuit is provided by a 9-volt alkaline battery via switch *S1*. Quiescent current drain is approximately 1 mA, so long battery life can be expected.

The delay between the arrival of the triggering light pulse and the actuation of the secondary flash can be varied from approximately 0.1 to 1 second. For shorter delays, the value of *C1* can be reduced to 0.1 μ F. If this is done and *R3* is set for minimum resistance, the delay is so short that the attached flash unit can be used as a simple slave. Light from the slave will reinforce that from the camera-triggered unit and will yield brighter or more diffuse lighting of the subject. Of course, a number of basic Poor Man's Strobes can be built and each one adjusted for a different delay time to produce multiple images on a single emulsion.

Other Circuits. The slave-trigger circuit in Fig. 2 has practically no delay at all. It is therefore suitable for situations in which the slight delay introduced by the timing circuit of the PMS would cause an undesirable second image or smearing. This circuit has two unusual characteristics—it is not triggered by steady-state ambient light, and it derives its modest operating power from the flash to which it is connected.

Although ambient light would tend to cause phototransistor *Q1* to conduct, inductor *L1* prevents this from happening. Upon receipt of a light pulse, however, a voltage is set up across the inductor and the base-emitter junction of the phototransistor, and the device briefly conducts. This in turn forward-biases the base-emitter junction of switching transistor *Q2*, and a positive voltage appears across *R12*. The SCR breaks into conduction and triggers the flash unit whose sync contacts are connected to jack *J1*. A manual trigger switch (*S1*) is wired in parallel with *SCR1*. Power for *Q1* and *Q2* is derived from the flash unit by means of voltage divider *R3R4* and storage capacitor *C1*, which is wired in parallel with the *R3* leg of the voltage divider. The circuit's power requirements are so modest that almost any flash unit can easily satisfy them.

The circuit shown in Fig. 3 is a sequential flash trigger that can ac-



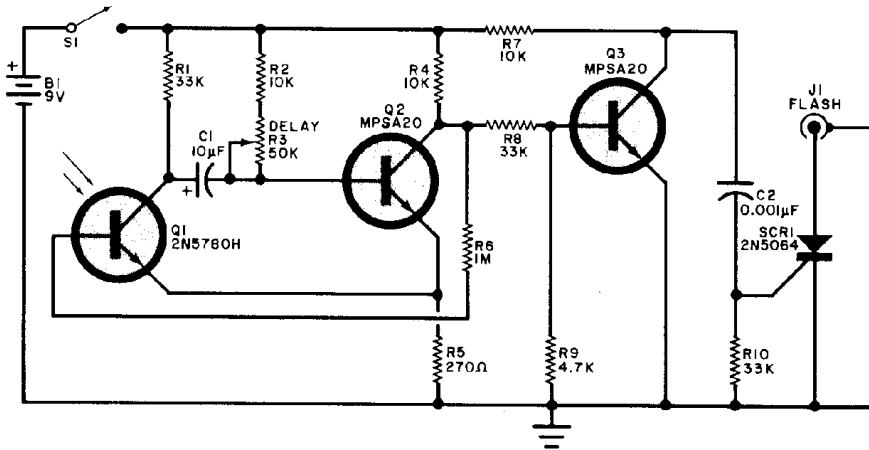
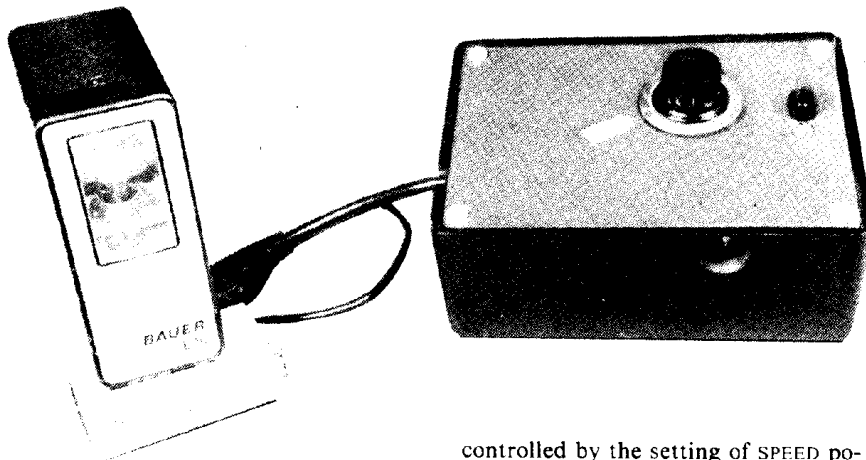

Fig. 1. Schematic diagram (above) of the basic Poor Man's Strobe. Below, a photograph of the author's prototype. The large control knob determines delay between trigger pulse and actuation of flash.



tuates as many as five flash units. These units will be triggered at equal intervals after the camera's sync contacts close. The circuit functions as follows: when the sync contacts close, transistor *Q3* cuts off and capacitor *C2* begins to receive charging current from the constant-current source comprising *Q4*, *Q5*, and their associated passive components. The ramp voltage that appears across the capacitor is coupled to position 1 of switch *S2* by Darlington emitter follower *Q6*. If *S2* is in position 1, the ramp voltage is applied to the gates of *SCR2*, *SCR3*, *SCR4*, and *SCR5* through a series of voltage dividers. The gate of *SCR1* receives a separate voltage pulse via a different circuit path almost immediately after the camera's sync contacts close.

As the ramp voltage at the pole of *S2* increases in amplitude, *SCR2*, *SCR3*, *SCR4*, and *SCR5* successively break into conduction and trigger the flash units to whose sync contacts they are connected. The rate at which the SCRs fire is determined by the slope of the ramp, which is ultimately

controlled by the setting of SPEED potentiometer *R9*. The lower the resistance of *R9*, the greater the output of the constant-current source. Thus, more current will flow through

LED1, and the LED will glow more brightly to indicate that the slope of the ramp will be steep and the flash sequence rapid. The total duration of the flash sequence can be adjusted from approximately 50 milliseconds to 3 seconds.

The monostable multivibrator comprising *Q1*, *Q2* and associated passive components performs two functions. First, it triggers *SCR1* when the camera's sync contacts close. Then, after three seconds, it resets the rest of the circuit to prepare for the next flash sequence. When switch *S2* is in position 2, the initial pulse across *R1* is simultaneously applied to the gates of *SCR1* through *SCR5*, triggering all the flash units simultaneously. Power

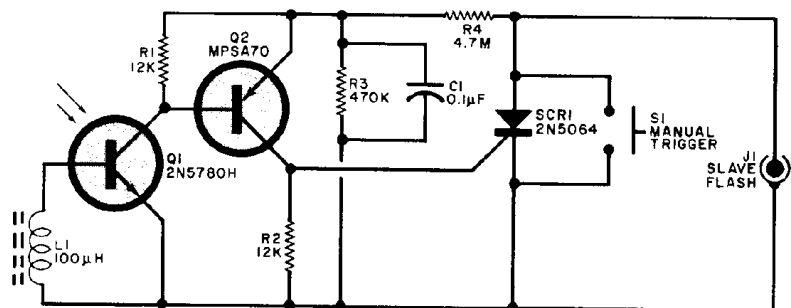

Fig. 2. Circuit for a slave-flash trigger that is not affected by steady-state ambient light.

PARTS LIST

- C1—0.1-µF, 250-V Mylar capacitor
- J1—Suitable jack (chosen to match the plug of the slave flash unit's sync extension cord)
- L1—100-µH choke
- Q1—2N5780H npn silicon phototransistor
- Q2—MPSA70 pnp silicon transistor

- R1,R2—12-kΩ, ¼-W, 10% resistor
- R3—470-kΩ, ¼-W, 10% resistor
- R4—4.7-MΩ, ¼-W, 10% resistor
- S1—Normally open, momentary-contact pushbutton switch
- SCR1—2N5064 or similar silicon controlled rectifier (minimum 200-volt rating)
- Misc.—Perforated board, sync extension cord, suitable enclosure, hookup wire, solder, hardware, etc.

PARTS LIST

- B1—9-volt alkaline battery
- C1—10-µF, 16-V tantalum capacitor
- C2—0.001-µF, 50-V disc ceramic capacitor
- J1—Suitable jack (chosen to match the plug of the flash unit's sync extension cord)
- Q1—2N5780H npn silicon phototransistor
- Q2,Q3—MPSA20 npn silicon transistor
- R1,R8,R10—33-kΩ, ¼-W, 10% resistor
- R2,R4,R7—10-kΩ, ¼-W, 10% resistor
- R3—50-kΩ, linear-taper potentiometer
- S1—Spst switch
- SCR1—2N5064 or similar silicon controlled rectifier (minimum voltage rating, 200 volts)
- Misc.—Perforated board, battery holder, battery clips, sync extension cord, control knob, suitable enclosure, hookup wire, solder, hardware, etc.

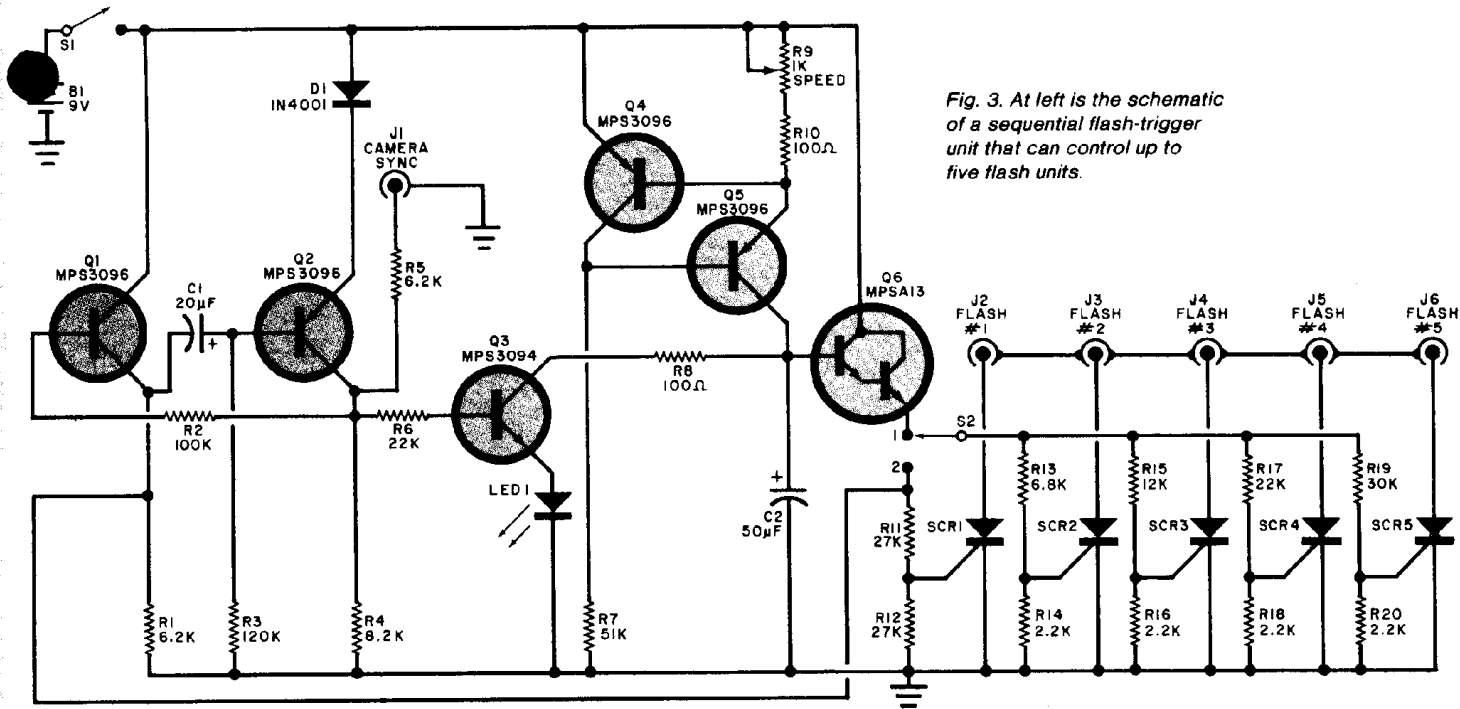

Fig. 3. At left is the schematic of a sequential flash-trigger unit that can control up to five flash units.

PARTS LIST

- B1—9-volt alkaline battery
- C1—20- μ F, 25-V aluminum electrolytic
- C2—50- μ F, 25-V aluminum electrolytic
- D1—1N4001 rectifier
- J1—Suitable jack (to match the plug of the camera's sync extension cord)
- J2 through J6—Suitable jacks to match the plugs of the sync extension cords for Flash #1 through Flash #5)
- LED1—Light-emitting diode
- Q1,Q2,Q4,Q5—MPS3096 pnp silicon switching transistor
- Q3—MPS3094 npn silicon transistor
- Q6—MPSA13 npn silicon transistor

- The following, unless otherwise specified, are $\frac{1}{4}$ -W, 10% tolerance, carbon-composition fixed resistors
- R1,R5—6.2 k Ω
 - R2—100 k Ω
 - R3—120 k Ω
 - R4—8.2 k Ω
 - R6,R17—22 k Ω
 - R7—51 k Ω
 - R8,R10—100 Ω , $\frac{1}{2}$ -watt
 - R9—1-k Ω , linear-taper potentiometer
 - R11,R12—27 k Ω
 - R13—6.8 k Ω

- R14,R16,R18,R20—2.2 k Ω
- R15—12 k Ω
- R19—30 k Ω
- S1—Spst switch
- S2—Spdt switch
- SCR1 through SCR5—2N5064 or similar silicon controlled rectifier (minimum voltage rating, 200 volts)
- Misc.—Perforated board, sync extension cords, suitable enclosure, battery holder, battery clips, control knob, hookup wire, LED mounting collar, solder, hardware, etc.

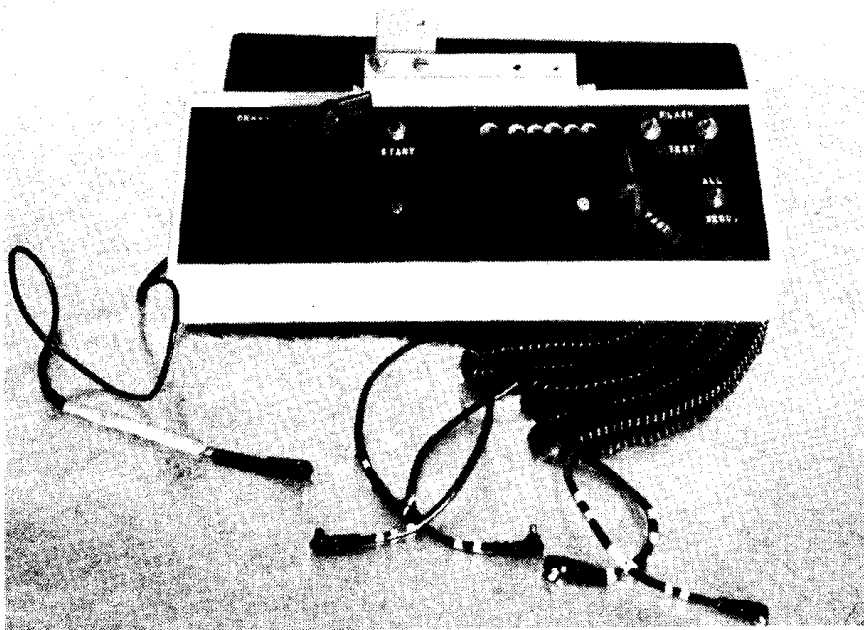

Photo of the prototype sequential flash-trigger unit.

for the circuit is supplied by 9-volt alkaline battery B1 via switch S1.

Another sequential flash trigger circuit is shown schematically in Fig. 4. Here, the trigger pulse from the camera's sync contacts enables unijunction transistor Q1 to generate clock pulses that drive CMOS decade counter/decoder IC1. The rate at which clock pulses are generated is determined by the position of rotary switch S3, which selects one of five RC timing networks (R22C3 through R26C7). The gate of SCR1 is driven by the output pulses of the UJT, but the gates of the other SCRs are driven by various of the counter's decoded output lines. Switch S1 allows the user to determine whether the gate of SCR5 will be driven by the Q4 or Q6 output line of the counter—that is, whether the flash unit connected to

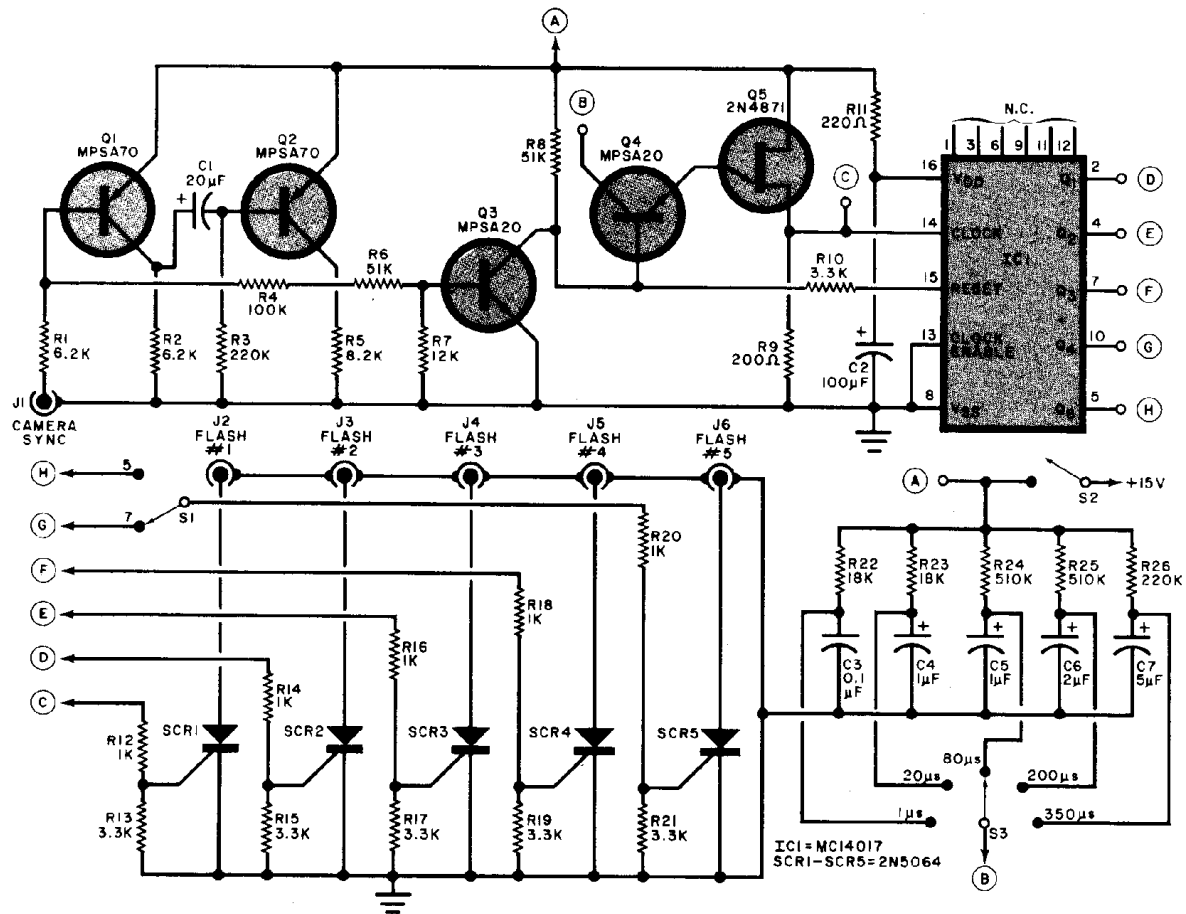

Fig. 4. Another sequential flash-trigger unit. This circuit employs a UJT clock and a CMOS decade counter/decoder.

PARTS LIST

C1—20- μ F, 25-V aluminum electrolytic
 C2—100- μ F, 25-V aluminum electrolytic
 C3—0.1- μ F, 50-V Mylar capacitor
 C4,C5—1- μ F, 25-V tantalum capacitor
 C6—2- μ F, 25-V tantalum capacitor
 C7—5- μ F, 25-V tantalum capacitor
 IC1—MC14017 decade counter/decoder
 J1—Suitable jack (to match the plug of the camera's sync extension cord)
 J2 through J6—Suitable jacks (to match the plugs of the sync extension cords for Flash #1 through Flash #5)
 Q1,Q2—MPSA70 pnp silicon transistor
 Q3,Q4—MPSA20 npn silicon transistor

Q5—2N4871 unijunction transistor
 The following, unless otherwise specified, are 1/4-W, 10% tolerance, carbon-composition fixed resistors.
 R1,R2—6.2 k Ω
 R3,R26—220 k Ω
 R4—100 k Ω
 R5—8.2 k Ω
 R6,R8—51 k Ω
 R7—12 k Ω
 R9—200 Ω
 R10,R13,R15,R17,R19,R21—3.3 k Ω
 R11—220 Ω
 R12,R14,R16,R18,R20—1 k Ω

R22,R23—18 k Ω
 R24,R25—510 k Ω
 R26—220 k Ω
 S1—Spdt switch
 S2—Spst switch
 S3—Single pole, 5-position nonshorting rotary switch
 SCR1 through SCR5—2N5064 or similar silicon controlled rectifier (minimum 200-volt rating)
 Misc.—+15-volt power supply or battery, perforated board, sync extension cords, suitable enclosure, IC socket, control knob, hookup wire, solder, hardware, etc.

jack J6 will fire at the fifth or seventh clock pulse. As in the circuit of Fig.3, a monostable multivibrator built around Q1 and Q2 resets the circuit to prepare for the next flash sequence. Power for the circuit is provided by a +15-volt supply (not shown) via switch S2.

Construction. The prototype Poor Man's Strobes were assembled using

perforated board and point-to-point wiring. However, printed-circuit construction can also be used. Type 2N5064 silicon controlled rectifiers are specified for each of the circuits that have been described. These devices have TO-92 plastic packages and are rated at 200 volts peak blocking voltage, 200 μ A gate trigger current, and 6 amperes peak forward surge current. They are compatible

with most flash units on the market. However, if you intend to use a flash unit that impresses more than 150 volts or so across its sync terminals, an SCR with a greater peak blocking voltage rating will have to be used.

Circuit layout is not critical, and the projects can be housed in any convenient enclosures. The various input and output jacks should be selected to match the plugs of the sync extension

cords that your photographic gear employs. Photographs of the prototypes whose circuits are shown in Figs. 1 and 3 appear with the respective diagrams. In the circuits of Figs. 1, 3 and 4, the use of alkaline cells will extend battery life. Be sure to observe standard CMOS handling procedures for *IC1* of Fig. 4 and to use an IC socket to mount it.

Using the Poor Man's Strobes.

As with any photographic hardware, a good deal of experimentation is required to learn how to use the Poor Man's Strobes for the best results.

Start with two flash units in an unlit room with dark walls or wall coverings. If you are using the circuit shown in Fig. 1, connect one flash to the camera's sync contacts and the other to jack *J1*. If you are using one of the circuits shown in Figs. 3 and 4, connect one flash unit to *J2* and the other to *J3*. Run a sync extension cord from the camera to input jack *J1*. Place your camera in its "B" (bulb) exposure mode and either set the object to be photographed in motion or direct your model to move around the room. Trip the shutter and hold it open. One flash will fire immediately, and the other will be triggered after a delay. Release the shutter after the second flash has fired.

This first trial should be a "dry run" with no film in the camera. Your eyes will register the strobed images. Repeat the experiment several times, varying the delay between the triggering of the two flash units and the rate at which the object or model is moving. If you have built several of the basic Poor Man's Strobes or one of the sequential trigger circuits shown in Figs. 3 and 4, add more flash units to see how multiple-flash stroboscopic photographs will look.

Next, determine a sequence of connecting the flash units to the output jacks and applying power that does not result in inadvertent triggering of the units. The proper procedure might be as follows: apply power to the Poor Man's Strobe; connect the flash units to it; and finally apply power to the flash units.

Once you have acquired a feel for the Poor Man's Strobe, you can take real pictures. Here again experimentation is needed. Vary the positions of the flash units, use different levels of light output, and for color work place different color filters on each flash unit. With a bit of experience, you'll be able to turn out interesting and unusual photographs that are as much fun to display as they are to take. ◇