

# ADD A "KEY-DOWN" AUDIBLE SIGNAL TO YOUR COMPUTER KEYBOARD

BY ROY AUER, Jr.

Simple circuit provides audible confirmation  
that a key has been struck properly

**T**HE action of some modern computer keyboards is extremely "light." As a result, even an attentive user may press a key but not cause generation of the desired character. Presented here is a simple circuit that produces a brief audible tone every time a key contact is actuated and a character is generated. It gives the user audible reassurance that the selected key has been properly pressed, and thus improves his efficiency. The circuit can be assembled on a compact circuit board and tucked into a small, free space inside the keyboard enclosure. Its modest power requirement can be easily satisfied by the host keyboard's power supply.

**About the Circuit.** The tone generator is shown schematically in the Figure. It employs the two timer circuits contained in the readily available NE555 dual timer chip. One section is used as a monostable multivibrator, the other as an astable multivibrator.

The monostable generates a 100-mil-

lisecond pulse upon the receipt of a "keystroke" pulse from the keyboard. Such a pulse is generated every time a key contact is actuated and the corresponding character is generated. Duration of the monostable multivibrator's output pulse, which appears at pin 5, is determined by the values of  $R1$  and  $C1$ . When pin 5 switches from ground potential to  $+V$ , the astable multivibrator begins to oscillate and produces an audio-frequency pulse train at pin 9. The frequency of the pulse train is determined by the values of  $R3$ ,  $R4$ , and  $C4$ , and the duty cycle by the relative values of  $R3$  and  $R4$ . For the values specified, the frequency of the pulse train is about 1 kHz with 67% duty cycle.

Note that three CMOS NOR gates are employed in the circuit. Actually, either  $IC1A$  and  $IC1B$  or  $IC1C$  will be used. If the keyboard with which the circuit will be used generates a positive keystroke pulse,  $IC1C$  must be employed to invert it into the negative pulse that the monostable multivibrator re-

quires for triggering. In that case, pins 8 and 9 of  $IC1C$  should be connected to the keyboard's keystroke pulse line and pin 10 of  $IC1C$  to pin 6 of  $IC2$ . Pins 1 and 2 of  $IC1A$  should be connected to either  $+V$  or ground and pin 4 of  $IC1B$  should be left unconnected.

If the keyboard generates a negative keystroke pulse, no inversion is necessary. In this case, however,  $IC1A$  and  $IC1B$  should be used as a noninverting buffer between the keystroke pulse line and the trigger input of the monostable multivibrator. Pins 1 and 2 of  $IC1A$  should be connected to the keystroke pulse line, pin 4 of  $IC1B$  to pin 6 of  $IC2$ , pins 8 and 9 of  $IC1C$  to either  $+V$  or ground, and pin 10 of  $IC1C$  should be left unconnected.

Three possible output configurations are shown in the Figure. At the top is a high-impedance crystal transducer. This transducer ( $TR1$ ) can be driven directly by the circuit and can be either a conventional crystal earphone or one of the recently developed piezoelectric "wafer"

Schematic diagram of the gated tone generator. Three possible output configurations are at right.

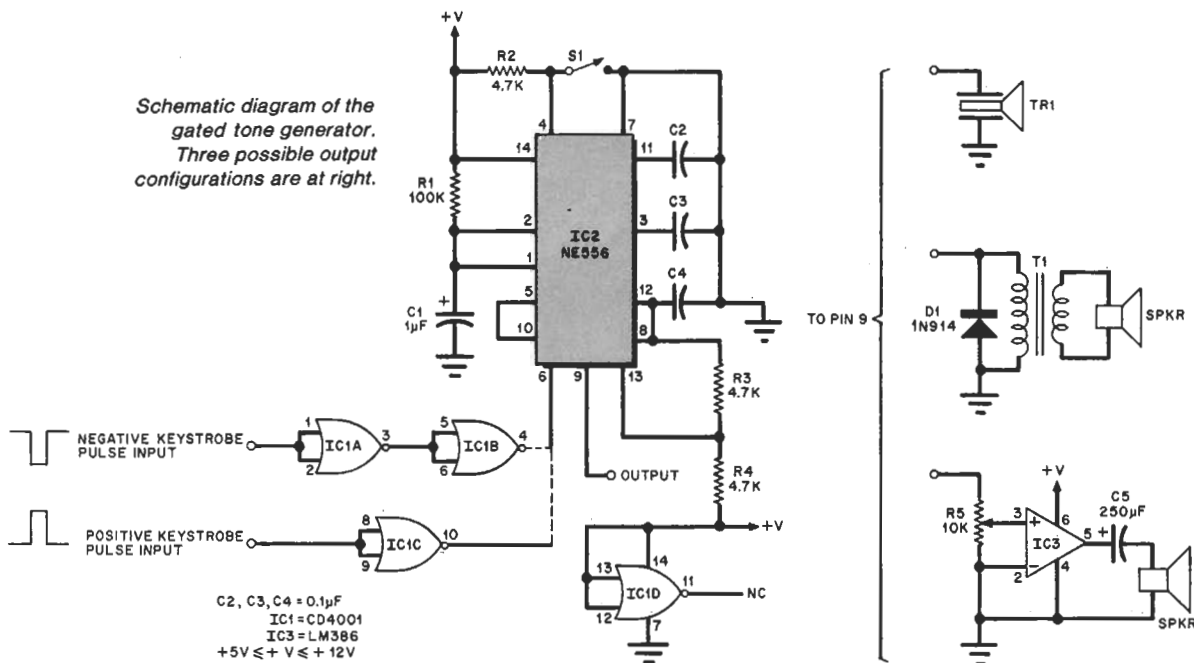

C2, C3, C4 = 0.1µF  
 IC1 = CD4001  
 IC2 = NE556  
 IC3 = LM386  
 +5V ≤ V ≤ +12V

**PARTS LIST**

- C1—1-µF, 25-volt electrolytic
- C2, C3, C4—0.1-µF disc ceramic capacitor
- C5—250-µF, 25-volt electrolytic
- D1\*—1N914 signal diode
- IC1—CD4001 quad NOR gate
- IC2—NE556 dual timer
- IC3\*—LM386 audio amplifier

- The following, unless otherwise specified, are 1/4-watt, 10% tolerance fixed carbon-composition resistors.
- R1—100 kΩ
  - R2, R3, R4—4.7 kΩ
  - R5—10-kΩ logarithmic-taper trimmer potentiometer
  - S1—Spst switch

- SPKR\*—8-Ω dynamic speaker
- T1\*—10-kΩ to 8-Ω audio transformer
- TR1\*—High-impedance crystal transducer
- Misc.—Printed circuit or perforated board, IC sockets or Molex Soldercons, suitable power source and enclosure, hookup wire, solder, hardware, etc.
- \*—Optional; see text.

transducers. If an earphone with a screw-in earplug is employed, best results will be obtained with the earplug removed. The author reports that a suitable crystal earphone can generate sound levels audible at distances of up to ten feet.

The middle alternative is to have the circuit drive a low-impedance dynamic loudspeaker. Here, a small audio output transformer (T1) couples the output of the astable multivibrator to the speaker. Diode D1 protects the astable multivibrator's output transistor from inductive spikes that can appear across the transformer primary.

The output configuration appearing at the lower right can provide a considerable sound pressure level. The output signal at pin 9 of IC2 is applied to potentiometer R5, which functions as a level control. Audio amplifier chip IC3 boosts the signal present at its noninverting input and drives a low-impedance dynamic loudspeaker via coupling capacitor C5. As shown, IC3 has a voltage gain of 20. This is adequate for most applications but can be increased to 200 by connecting a 10-µF electrolytic capacitor

between pins 1 and 8 of IC3. The IC can be powered from the same source as the rest of the circuit because its current demand is modest.

Toggle switch S1 controls the action of the monostable timer section of IC2. When the switch is open, the positive supply voltage is applied to the monostable multivibrator's RESET input (pin 4). This allows the timer to function normally. However, when the switch is closed, the monostable's RESET input is grounded and that timer's output (pin 5) is frozen at ground potential. When this happens, the astable multivibrator is disabled and no tone can be produced. Therefore, if the user does not want a tone to be generated each time a key contact is actuated, S1 should be closed.

**Construction.** Because the project is relatively simple, it can be assembled on a small perforated or printed-circuit board. The use of IC sockets or Molex Soldercons is recommended. Be sure to observe the polarities of power supply leads, semiconductors, and electrolytic capacitors. Employ the minimum amount of heat and solder consistent

with the formation of good solder joints. The project can be connected to the keyboard by suitable lengths of insulated, stranded hookup wire. If space permits, the project can be mounted inside the keyboard enclosure. Alternatively, it can be installed in a small enclosure of its own.

**In Conclusion.** Auditory confirmation of a proper key-contact actuation can speed and simplify the use of an ASCII or similar keyboard. The circuit that has been presented here will provide such confirmation and make the time spent at a keyboard more productive and enjoyable. If desired, the values of the resistors and capacitors associated with the two timer sections of IC2 can be changed to suit the taste of an individual user. Increasing the time constant of R1C1 will result in a longer "beep." Decreasing it will shorten the time that the astable multivibrator oscillates. The frequency and duty cycle of the audio output can be modified by appropriate changes in the values of R3, R4, and C4. Consult a 556 data sheet for the appropriate design equations. ◇