

General Description

Following in the time-honored tradition of the Rane Corporation Engineering department's never-ending quest to make the most out of the least, here is the revolutionary sonic enhancement product, the Rane PI 14. Limitations of space and patience preclude detailing all the limitless virtues of this acoustic stimulator, however one must make due with the allotted time and size and put down at least a rudimentary sketch of this marvelous piece of gimmickry.

Over the years, the sciences of audio production and reproduction have evolved slowly. Too slowly for Rane engineering. So, with a little clever application of some otherwise tawdry electrical components, we bring you the PI 14. Not just an evolution, no way. It's a revolution.

Have you ever wanted to add just a bit of this or a tad of that to your sound? Have you ever wondered what was available to allow it? So have we. The PI 14 gives you the ability to add bits of this and dashes of that, with continuously variable breadth and depth. How much would you pay for this flexibility? But wait. Before you answer that, there's also the

ability to pan from here to there and if you lose your way, there's a switch to get you back again. And if you don't care for the spectral distribution of the difference between this and that, there is a special Rinkwitz Liley 4th grade crossover filter which may be used to control spectral harmony.

The Sheen reduction processor included in the overwhelmingly complex circuitry of the PI 14 reduces to a bare memory the graininess and shimmer present in many modern recordings digitally processed without the assistance of an inverse PI 14 digital dither shield. Now how much would you pay? Yes Martha, there's more. More in the form of the rotary Ecstasy presence control at the far right hand side of the PI 14's control panel. This knob can restore life to even the most nauseous recordings of the past. Don't dispose of those old bubble gum (or bubble machine) recordings taking up space in your library. The PI 14 adds just enough of this or that to these legendary vinyl dinosaurs to make them worth the 9 styli you'll wear out playing just one of them. Now how much would you pay? Let us know.

Features

- Independent Power & Glory Switches
- Continuously Variable This/That Level
- Full-Function Ecstasy Generator
- Variable This to That Crossover Frequency
- Here-There Pan (Back Again Switching)
- Program Dependent Sheen Removal
- Anti-Resonant Concrete Chassis
- Proprietary Paint to Reflect Odd Harmonic Light Frequencies to Reduce Non-linear Photon Radiation Interference
- Time Warp Compression/Expansion to Synchronize Here/There Time Coordinates

Applications

- New Age Seminars
- Car Washes
- High School Cafeterias
- Funeral Homes
- Executive Washrooms
- High End Audio Demo Rooms
- Community Access Cable Channels
- Airport Baggage Claim Areas
- Cars With Tiny Steering Wheels
- Communications Scrambling
- Railroad Crossing Warning Systems
- Door Stops



Features and Specifications

Parameter	Specification	Limit	Units	Conditions/Comments
Crossover: Alignment	Rinkwitz-Liley			4th-Grade State-Penitentiary
.....Slopes	2.4 dB/Octave			Sex Switchable
.....Range	75-3.6 kHz This to That			
Inputs: Type	Activist Off-Balanced			
.....Connectors	3-Pin Happy Face			
.....Impedance	20M	.1%	ohms	
.....Maximum Level	11			Spinal Tap Taper
Outputs: Type	Regenerative Aural Byproducts			
.....Connectors	3-Pin Mr. Bill			
.....Conductance	.0017	.1%	Mhos	.00085 Mhos Each Leg to Ground
.....Maximum Level	450%	1	Qts	SAE 10-40 or Greater
Sonic Purity	A-1			Gives Good Tone
RFI Filters	Yes			Stupid Question
On/Off Transient Muting	Sometimes			Really Stupid Question
Passive Resistance	When Required			Nonviolent Ohms
LEDs:				
.....Overload	22	1	Shots	Magazine or Cartridge
.....Signal Present	-20	1	dBu	More or Less Input Level
Diffusion Coefficient	D	.1%	cm /s	Obeys Fick's First Law
Deep Six Filter	19.9 Hz 180 dB/Oct, Brickwall	.1%	Hz	(Rane Hates Rumble)
Ultraviolet Filter	1.4	.1	nm	Corning CS 7-63, Amethyst
Frequency Response	0.1-66 MHz	+ 0/-3	dB	Ch. 4 (Ch. 3 in some areas)
Slew Rate	13	2	f/fin	(1 furlong/fortnight = 0.00655 in/sec)
THD + Noise	0.00007	.0001	%	Clean - Very Clean
IM Distortion (SLEAZ)	0.0004	1	%	60 Hz/61 Hz, 1:1, -60 dBu
Signal-to-Noise Ratio				re Screaming Kids in Background
	192	2	dB	This/That Centered, Unity Gain
	50	2	dB	This/That Centered, Max Gain
	0	2	dB	This/That Max, Max Gain
Agency Approval	Good Housekeeping			
Mil Spec	Rad Hard Components			
Power Supply	Digital Servo-Locked Regulators			
Maximum Power Usage	12		kW	
Line Voltage: Domestic	116-117 VAC, 33 1/3Hz			
.....Export	221-222 VAC, 78 Hz			See Above
Unit: Construction	All Concrete			
.....Size	1.75"H X 19"W X 5.3"D (IU)			
.....Weight	117 lbs			(53 kgs)
Shipping: Size	7" x 22" x 13"			(18 cm x 56 cm x 33 cm)
.....Weight	117 lb			(55.8 kg)
Note: 12 inches = 1 foot				

Block Diagram

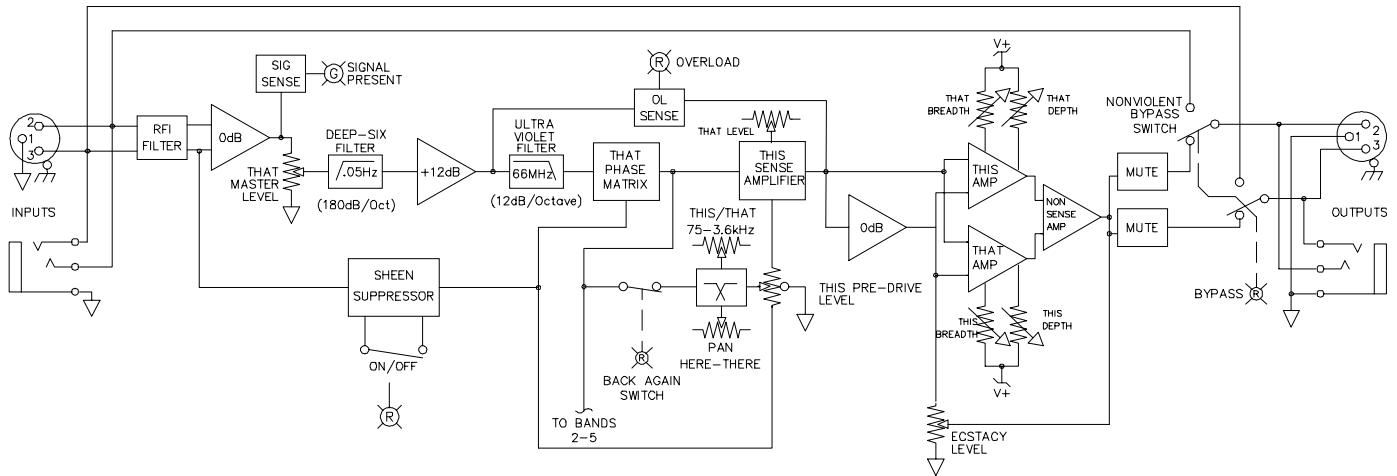

Application Information

A shaky this maybe acceptable and, conceivably, a questionable that is tolerable, but no system can simultaneously sustain a jittery this and that. And when panoramic sweeping from here to there is required, nothing does the job just right. For these reasons, Rane Corporation developed the PI 14 Pseudoacoustic Infector.

Nothing has been left out. Transparent to the user but essential to the design is the 128 bit microcontroller running the front panel. Rane's exclusive artificial intelligence (AI) algorithm determines whether the user knows what he's (it's always a he; she's are too smart to buy this thing) doing. The AI controller always overrides totally stupid input. In addition, an autopilot mode exists, whereby the AI controller predetermines what the operator wants, and executes it beforehand. And finally, the AI controller features DWIWNWIS (Do what I want, not what I say) trouble free control interface.

Several envelope-pushing unique features beg attention

Such as the pneumatic suspension to reduce gravitational electron drift due to tilted chassis; such as the proprietary paint that reflects odd-ordered harmonic light frequencies to reduce non-linear photon radiation interference; such as Rane's patent pending (in 3 galaxies) Time Warp Compression/Expansion to synchronize Here/There time coordinates; such as the Interdimensional Stabilizer essential for This and That; such as the 10 megawatt mini fusion reactor power supply for those demanding audio transients - and featuring the first use of nearly room temperature (-146° C) bismuth superconductors. (It should be noted that the cooling system is not provided, but is required.) No expense has been spared.

And the physical construction is exquisite. Utilizing another Rane first, the all concrete chassis and front panel, the PI 14 displays unequalled vibrational stability. And with the optional aggregate front panel the Pseudoacoustic Infector is a wonder to fondle.

Rear Panel

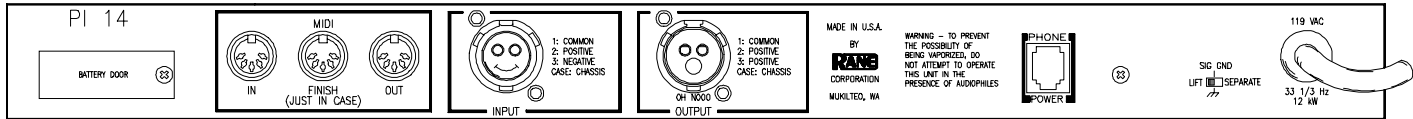

Architectural Specifications

The pseudoacoustic infector shall be a two channel unit with built-in crossover capability. The unit shall be able to add this and that to any audio signal being processed. In addition, panning from here to there (and back again) is required.

The breadth and depth of any desired this or that shall be adjustable from off to a maximum of 11, with a spinal tap taper.

The active crossover shall contain 4th-grade, state-penitentiary, Rinkwitz-Liley aligned filters. The high-pass and lowpass outputs of the filters shall crossover at an amplitude of +6 dB from the unity passband level and be electrically out of phase. No provisions shall exist to correct for driver misalignment. Misaligned drivers are stupid and shall be the installation jerk's responsibility.

Crossing over from here to there shall be controlled by a cheap intermittently variable, our-gang potentiometer with 3 separate detents to allow mechanical mis-reference of crossover settings.

Signal inputs shall be activist off-balanced designs terminated with 3-pin happy face connectors. Signal outputs

shall be of equally deranged design with balanced output conductance terminated in 3-pin Mr. Bill connectors. RFI filters shall be provided, but must allow all emergency broadcast frequencies to pass. Transient On/Off muting shall not work reliably, and destructive thumbs shall occur regularly. Deep six and ultraviolet filters shall be built-in.

The pseudoacoustic infector shall afford an input level range of Off to +6 dB, and if they can't afford that, they should shop elsewhere. The output level controls shall be muted at all times. The channels shall switch their routing so automatically and in such a confusing manner that it shall be impossible to correctly connect the unit.

The pseudoacoustic infector shall have a power supply capable of operating only from exactly 119 VAC (219 VAC , where applicable) 33 1/3 Hz and be capable of powering an external telephone via a modular input jack. The unit shall be constructed entirely from cold-rolled concrete.

The pseudoacoustic infector shall not be just any pseudoacoustic infector. No, the pseudoacoustic infector had better be Rane's Pseudoacoustic Infector Model PI 14. (And if you don't spec it, someone quite nasty is going to pay you a visit.)

Available Accessories

- SC 1.7 Security Cover
- RAP 10 Remote Power Supply
- RS 1 Remote Power Supply
- Aggregate Front Panel

References

1. R. Moses, A. Claxton, S. Turnidge, and S. Macatee, "Boss Manipulation in the Audio Workplace," *J. Amer. Psychos*, vol. 88, pp. 19-19.5, (Sep. 1947).
2. S. Brakken, and L. Winter, "Aural Hallucinations for Fun and Profit," *Snake Oil Soc. Am.*, vol. 27, pp. 16-297, (Feb. 1991).
3. T. Pennington, and D. Bohn, "Adaptive This and That for Stereophonic Sweeping From Here to There: presented at the 163rd Convention of Readers Digest Society, *Readers Digest (Abstracts)*, vol. 1, pp. 1180-1365, (Dec. 1876), preprints confiscated.