



Reference Series 1600a

1 CHANNEL POWER AMPLIFIER

SERVICE MANUAL



Infinity Systems, Inc.
250 Crossways Park Dr.

Woodbury, New York 11797

Rev1 3/2008

Released 2007

Discontinued XXXX

- CONTENTS -

BASIC SPECIFICATIONS	1
DETAILED SPECIFICATIONS	2
PACKING.....	3
APPLICATIONS.....	4
INSTALLATION/SETUP.....	5
BASIC TROUBLESHOOTING.....	5
EXPLODED VIEW/PARTS LIST.....	6
NOTE ON TOP COVER.....	7
AMPLIFIER BLOCK DIAGRAM.....	8
P.C.B. DRAWINGS.....	9
ELECTRICAL PARTS LIST	18
IC/TRANSISTOR PINOUTS.....	23
SCHEMATICS.....	26

Reference 1600a Basic Specifications

Output Power:	400W RMS x 1 @ 4 ohms; ≤1% THD + N
(14.4 VDC)	600W RMS x 1 @ 2 ohms; ≤1% THD + N
Signal-to-noise ratio:	80dBA (reference 1W into 4 ohms)
Dynamic power:	894W channels @ 2 ohms
Effective damping factor:	6.3 @ 4 ohms
Frequency response:	11Hz – 330Hz (-3dB)
Maximum input signal:	6.0V
Maximum sensitivity:	100mV
Output regulation:	.12dB @ 4 ohms
Dimensions (L x W x D):	14-3/16" x 9" x 2-11/16" (361mm x 229mm x 69mm)
Fuse:	3 x 25A

Infinity continually strives to update and improve existing products, as well as create new ones. The specifications and details in this and related JBL publications are therefore subject to change without notice.

INFINITY REFERENCE 1600a AMPLIFIER SPECIFICATIONS

TEST VOLTAGE 14.4 +0.1V			
Specification	Rating	Unit	Remarks
Power Output 4ohm loads @50Hz (stereo mode) for each ch @<1.0%THD (Unit:W)(LPF=22K)	≥400W x 1	Watts	
Power Output 2ohm loads @50Hz (stereo mode) for each ch @<1.0%THD (Unit:W)(LPF=22K)	≥600W x 1	Watts	
THD Power 4 ohm loads and 1MD@Reference (Unit:%) LPF=22K	≤0.1% @ 50Hz	%	
THD Power 2 ohm loads and 1MD@Reference (Unit:%) LPF=22K	≤0.1% @ 50Hz	%	
Full rated power Distortion 1KHz LPF=22KHz	≤0.1%	%	
Signal/Noise Ratio a: 1 watt into 4 ohms b: full rated power (dB)	80 >105	dB	1 watt into 4 ohms 1V signal input
Input Sensitivity Low Level Input(v) @:full rated power	100mV-6V	Volts	±20%
Frequency response (Unit:-3dB)	11Hz~330Hz	Hz	-3dB
Bass Boost:(Unit:dB) @45HZ (±5Hz)	0~6dB	dB	±1dB
Idle Current (@ 2ohm)	1.2A	A	±0.15A
MAX current : rated power (All channel 2 ohm loads)	≤58A	A	
DC Offset:	≤30mV	mV	
Damping Factor (4ohm):	> 200		
Effective damping factor (4ohm):	6.364		
Dynamic Power @ 2 ohms	894W	Watts	
Output Regulation @ 4 ohms	0.12dB	dB	
Remote Operating Voltages:	5V OFF 3.5V	Volts	±1V
Turn on delay time	2 to 3	Sec	
Circuit Protection a. Temperature b. Speaker Short Circuit c. Operating Voltage Range	80 ±5 deg C Yes 8~16V		
Dimensions (L x W x H):	14-3/16" x 9" x 2-11/16" (361mm x 229mm x69mm)	Inches mm	
Fuses	25A x 3	A	

PACKAGING

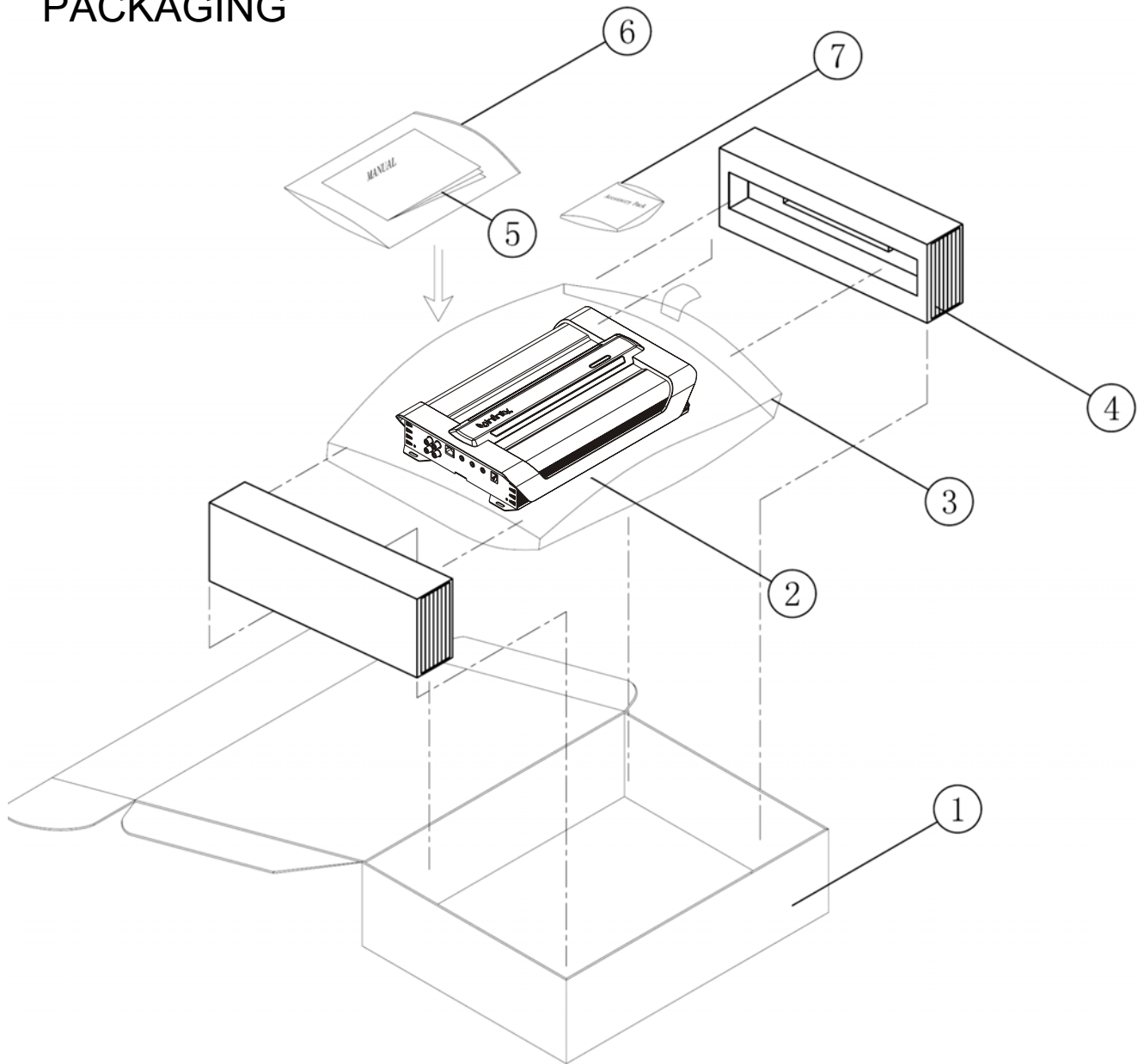

Item	Part Number	Description	Qty
1	CH4482901202	Outer Carton	1
2	REF1600a	REF1600a Amplifier	1
3		Plastic Bag	1
4	BZL279112001	Packing Foam	1
5	Visit Infinitysystems.com	Owner's manual	1
6		Plastic Bag	1
7		Accessory kit consisting of:	1
	LS1CJ0402507	Mounting Screws	4
	1601-253G-00	SPARE 25A FUSES	3
	REMOTE REF AMP	Remote Level Control	1
	2100-0009-04	(RJ11) control cable	1

APPLICATIONS – 1300a AND 1600a

The Reference subwoofer amplifiers are single-channel amplifiers. There are two sets of terminals to make it easy to connect multiple woofers. Either set of (+/-) terminals may be used when connecting woofers.

To the right are four application diagrams to help plan your subwoofer system installation.

NOTE: For simplicity, Figures 3 and 4 do not show power, remote and input connections.

Subwoofers or voice coils connected in series.

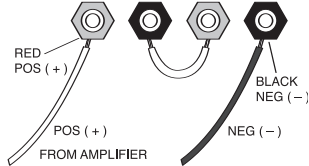

Subwoofers or voice coils connected in parallel.

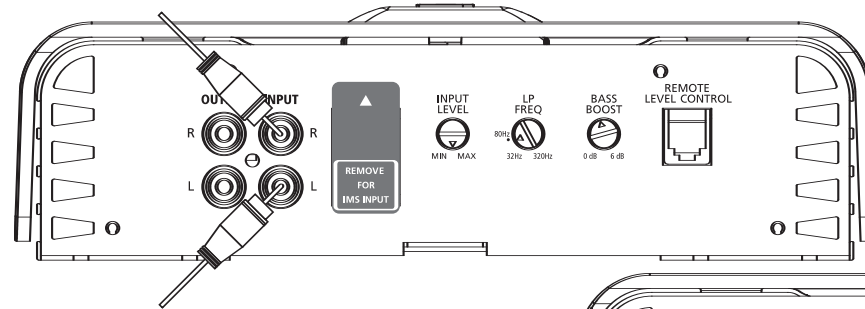
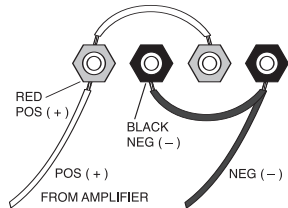
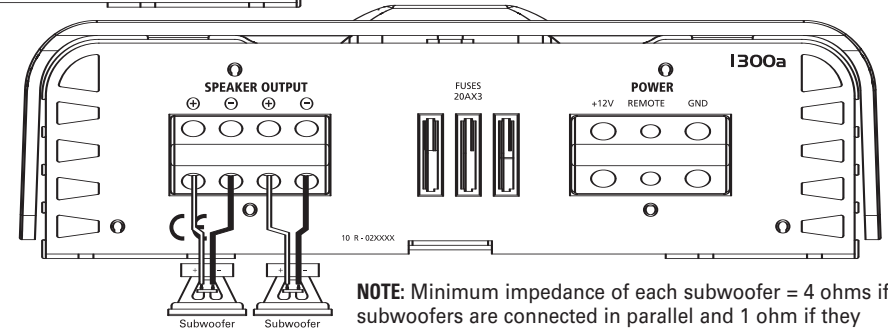

Figure 3. Reference 1300a or 1600a amplifier with two woofer connections.



NOTE: Minimum impedance of each subwoofer = 4 ohms if subwoofers are connected in parallel and 1 ohm if they are connected in series.

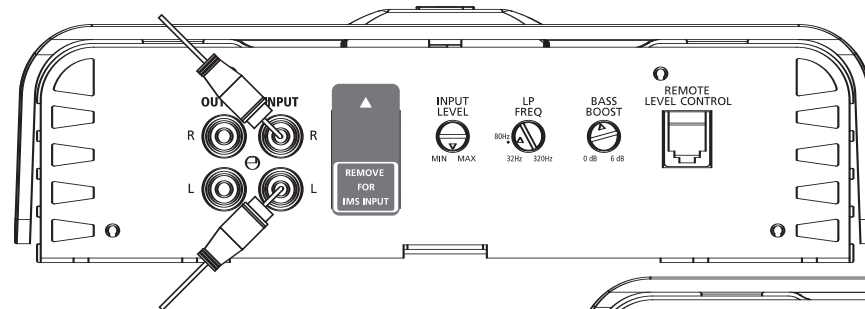
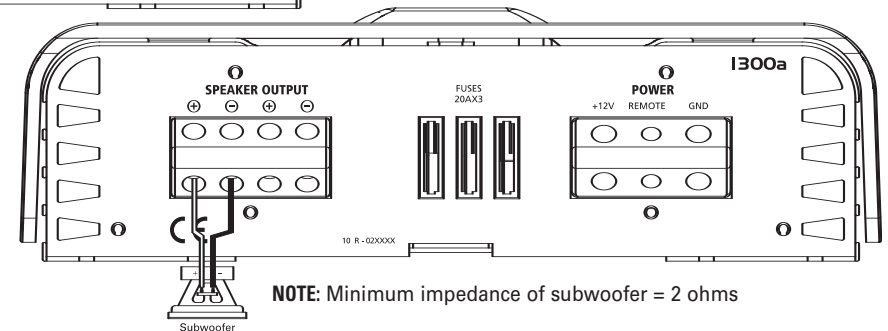

Figure 4. Reference 1300a or 1600a amplifier with one woofer connection.



NOTE: Minimum impedance of subwoofer = 2 ohms

INSTALLATION AND SETUP

Refer to the illustrations on the previous pages for control location.

Reconnect the (-) negative lead to the vehicle's battery. Apply power to the audio system and play a dynamic music track.

SETTING THE CROSSOVER(S)

Determine your system plans and set the crossover-mode switch accordingly. If your system design does not include a subwoofer, set the crossover mode to FULL and skip to "Setting Input Sensitivity."

If your system includes a subwoofer, set the crossover mode to HP (high-pass) for your full-range speakers. Adjust the crossover frequency to limit bass, and provide increased system volume with less distortion.

Mode Switch:

Full: Allows a full-range signal through to the speakers; can be used with larger full-range speakers such as 6" x 9"s.

HP: Allows a high-pass signal through to the speakers; should be used with most loudspeakers (can protect your full-range speakers from being overdriven with low frequencies, one cause of speaker damage).

LP: Allows only bass to pass through to the speakers; should be selected when powering subwoofers.

High-Pass Filters: Initially set the crossover-frequency control midway. While listening to music, adjust the crossover for the least perceived distortion from the speakers, allowing them to reproduce as much bass as possible.

Low-Pass Filters: For subwoofers, choose the highest frequency that removes vocal information from the sound of the subwoofer.

If using the 475a to drive a subwoofer(s), set the crossover mode to LP (low-pass) on the channels connected to the subwoofer.

NOTE: The 1300a, 1600a and the subwoofer output of the 5350a are low-pass only and do not have a crossover-mode switch.

SETTING INPUT SENSITIVITY

- Initially turn the INPUT LEVEL control(s) to the minimum (counterclockwise) position.
- On the source unit, increase the volume control to 3/4 volume. Slowly increase the INPUT LEVEL control(s) toward three o'clock until you hear slight distortion in the music. Then reduce the INPUT LEVEL slightly until distortion is no longer heard.

NOTE: After the source unit is on, blue LEDs (on the top panel) will light, indicating the amplifier is on. If not, check the wiring, especially the remote connection from the source unit. Also refer to "Troubleshooting."

REMOTE LEVEL CONTROL

The 1300a, 1600a and 5350a include a remote level control. This will allow the subwoofer level to be adjusted from the listening position. Connect the remote level control using the RJ11 jack on the side of the amplifier. Install the control module in the front of the vehicle within easy reach of the driver. Both the underside of the dash and the center console are suitable locations.

UNDER-DASH MOUNTING

Select a mounting location that allows easy access to the control while driving. Using the REMOTE LEVEL control as a template, mark and drill holes in the mounting surface. Attach the REMOTE LEVEL control using the mounting screws provided (Figure 11).

Figure 11. Under-dash mounting of the REMOTE LEVEL control.

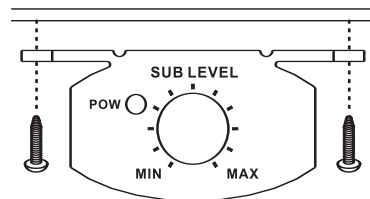

Route the cable behind the dash or other interior panels and under the carpet. Do not route the cable outside the vehicle. Connect the RJ11 cable between the RJ11 receptacle on the amp and the receptacle on the REMOTE LEVEL control (Figure 12).

Figure 12. REMOTE LEVEL control electrical connection.

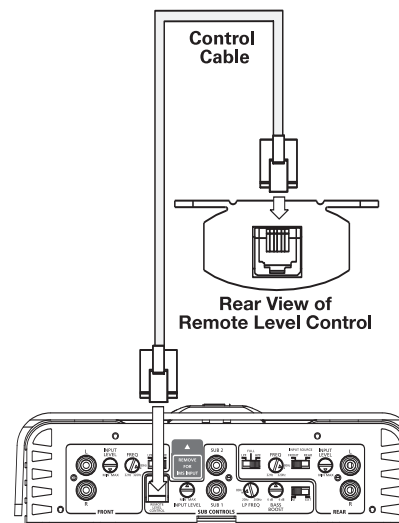

SETTING THE BASS BOOST

The Bass Boost control will allow you to enhance the bass output of your system at 50Hz up to 6dB.

AUX OUTPUT

Reference amplifiers (except 5350a) are equipped with full-range outputs that can be used to connect additional amplifiers.

STATUS LEDs

Power: Indicates the amplifier is on.

Protection: Refer to "Troubleshooting" for specific indications.

Figure 13. LED status.

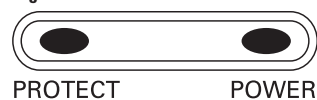

TROUBLESHOOTING

- PROBLEM:** No audio (POWER LED is off).
CAUSE and SOLUTION: No voltage at BATT+ and/or REM terminals, or bad or no ground connection. Check voltages at amplifier terminals with VOM.
- PROBLEM:** No audio (PROTECT LED glows red).
CAUSE and SOLUTION: DC voltage on amplifier output. Amplifier may need service; see enclosed warranty card for service information.
- PROBLEM:** No audio (PROTECT LED glows red).
CAUSE and SOLUTION: Amplifier is overheated. Make sure amplifier cooling is not blocked at mounting location; verify that speaker-system impedance is within specified limits.
- PROBLEM:** No audio (PROTECT LED glows red).
CAUSE and SOLUTION: Voltage less than 9V on BATT+ connection. Check vehicle charging system.
- PROBLEM:** No audio (PROTECT LED glows red).
CAUSE and SOLUTION: Voltage greater than 16V or less than 8.5V on BATT+ connection. Check vehicle charging system.
- PROBLEM:** Distorted audio.
CAUSE and SOLUTION: Input sensitivity is not set properly, or amplifier or source unit is defective. Check INPUT LEVEL setting, or check speaker wires for shorts or grounds.
- PROBLEM:** Distorted audio (PROTECT LED glows intermittently).
CAUSE and SOLUTION: Short circuit in speaker or wire. Remove speaker leads one at a time to locate shorted speaker or wire, then repair.
- PROBLEM:** Music lacks "punch."
CAUSE and SOLUTION: Speakers are not connected properly. Check speaker connections for proper polarity.

1600A EXPLODED VIEW

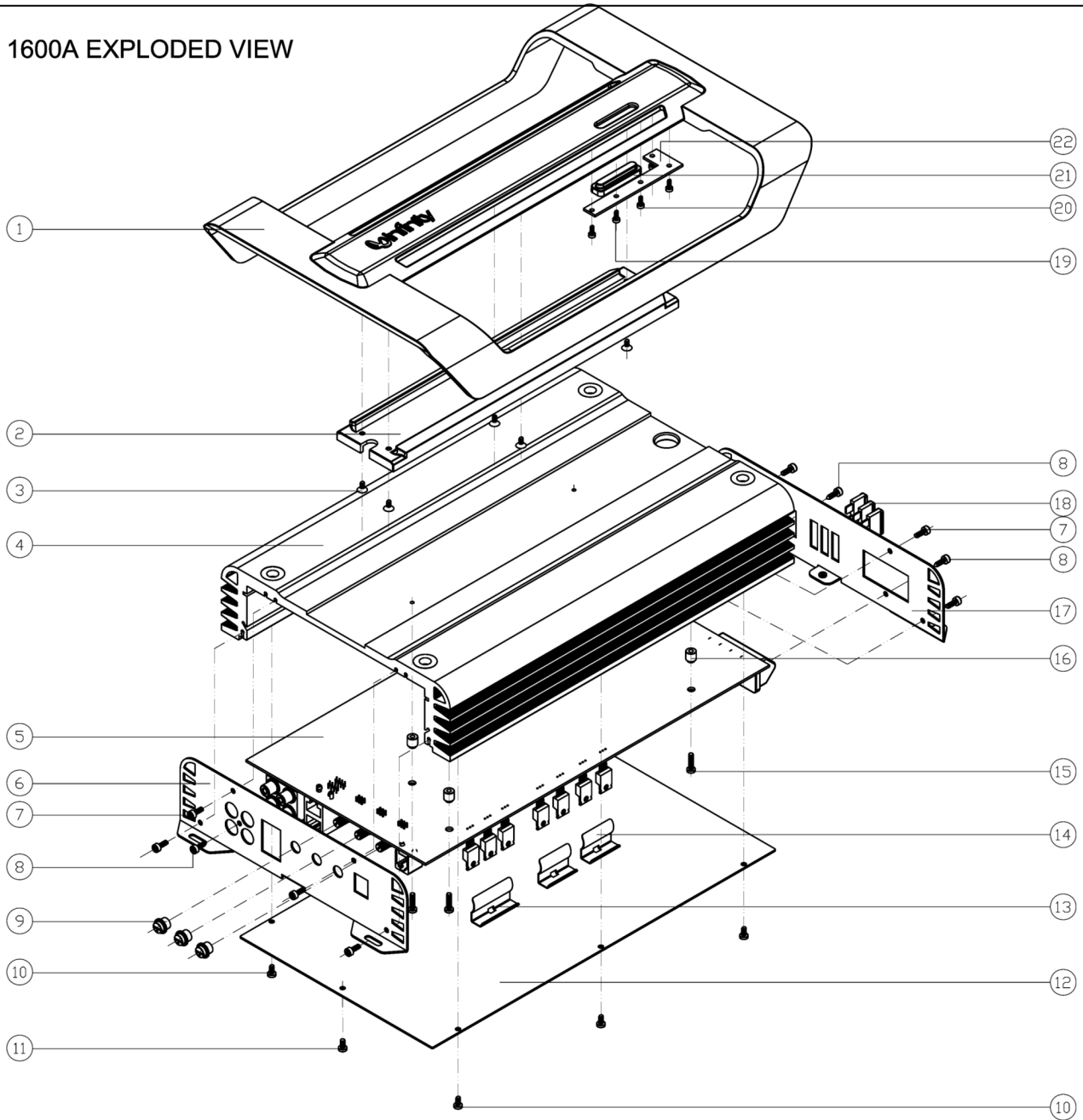

Item#	Part Number	Description	Qty
1	SG-0016-2601	Top cover	1
2	GD-600011400	Light panel	1
3	LSIFM0300011	Screw	5
4	SR-1300-0117	Main heat sink	1
5		Main PCB	1
6	MK-0004-2601	Front panel	1
7	LS5KP0300807	Screw for F/RP	8
8	LS5KJ0301007	Screw for terminal, RCA jacks	3
9	XN-10500-012	Knob	3
10	LSIAP0300607	Screw	6
11	LSIAM0300607	Screw	2
12	XG-0017-2601	Bottom plate	1
13	PL-L0007-000	Transistor spring clip (2)	1
14	PL-L0006-000	Transistor spring clip (1)	10
15	LSIAY0301201	Screw	4
16	ZL-10037A-15	Space Pole	4
17	HG-0005-2601	Rear panel	1
18	1601-253E-00	Fuse 25A ATC	3
19	LSIAA0200501	Screw	1
20	LS1AM0250401	Screw	4
21	CP-B00011400	LED lens	1
22		LED PCB	1

NOTE ON TOP COVER FOR INFINITY REFERENCE MODELS REF475A, REF1300A, REF1600A

- There was a revision in the top cover design starting with the serial number range(s) noted below, or identified by the brace design in the supplied images.
- Note the Rev1 Top cover will not fit properly on the original heatsink.

Top Cover Part Numbers

MODEL	PART NUMBER	SERIAL NUMBER
REF475A	SG-0016-2601	EV0001-01000 to EV0001-09138
REF475A	SG-0001-2607	EV0001-09139 And above
REF1300A	SG-0016-2601	EV0003-01000 to EV0003-08606
REF1300A	SG-0001-2607	EV0003-08607 And above
REF1600A	SG-0016-2601	EV0004-01000 to EV0004-11811
REF1600A	SG-0001-2607	EV0004-11812 And above

PART# SG-0016-2601 ORIGINAL TOP COVER



NEW TOP COVER PART # SG-0001-2607



Block Diagram REF1600

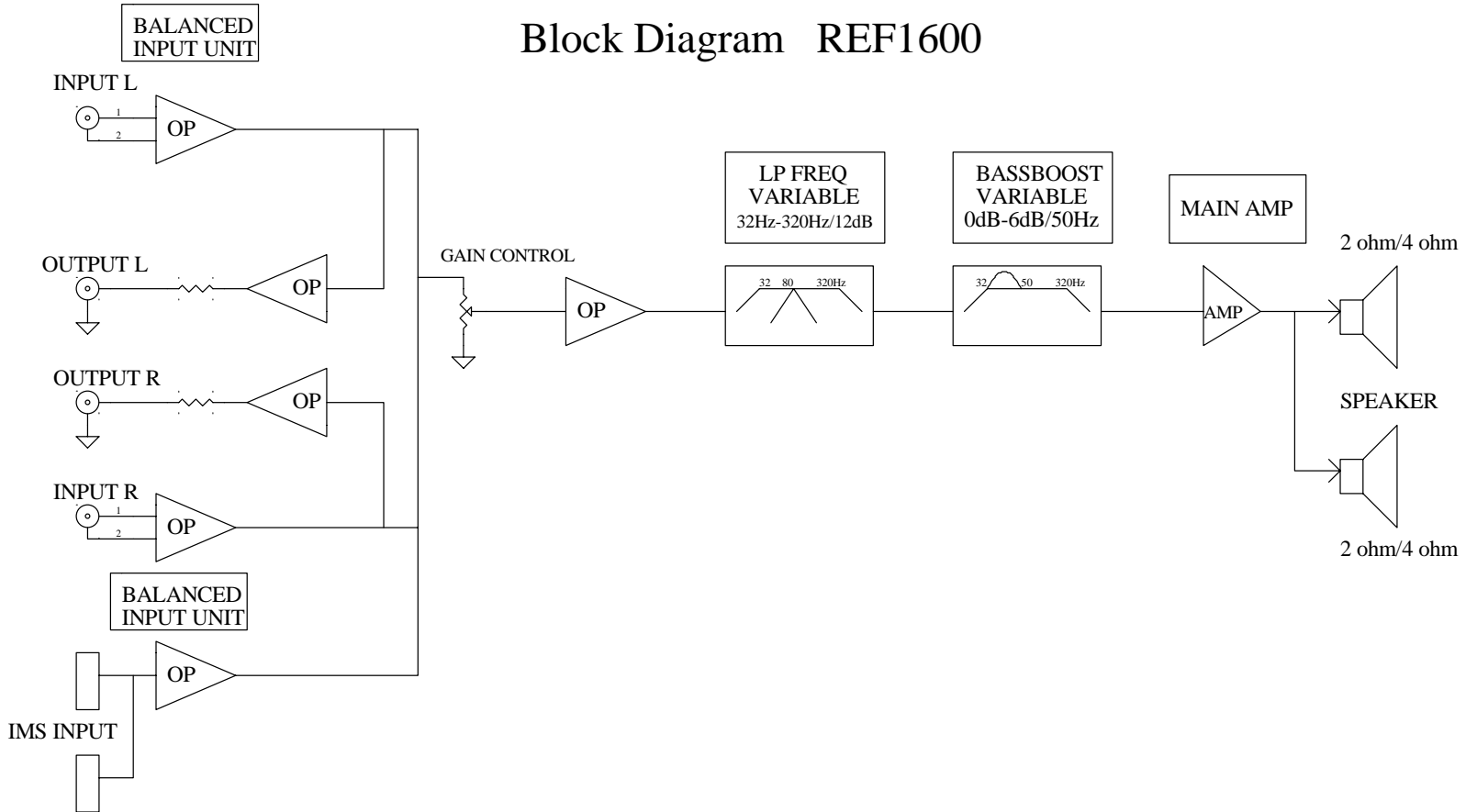

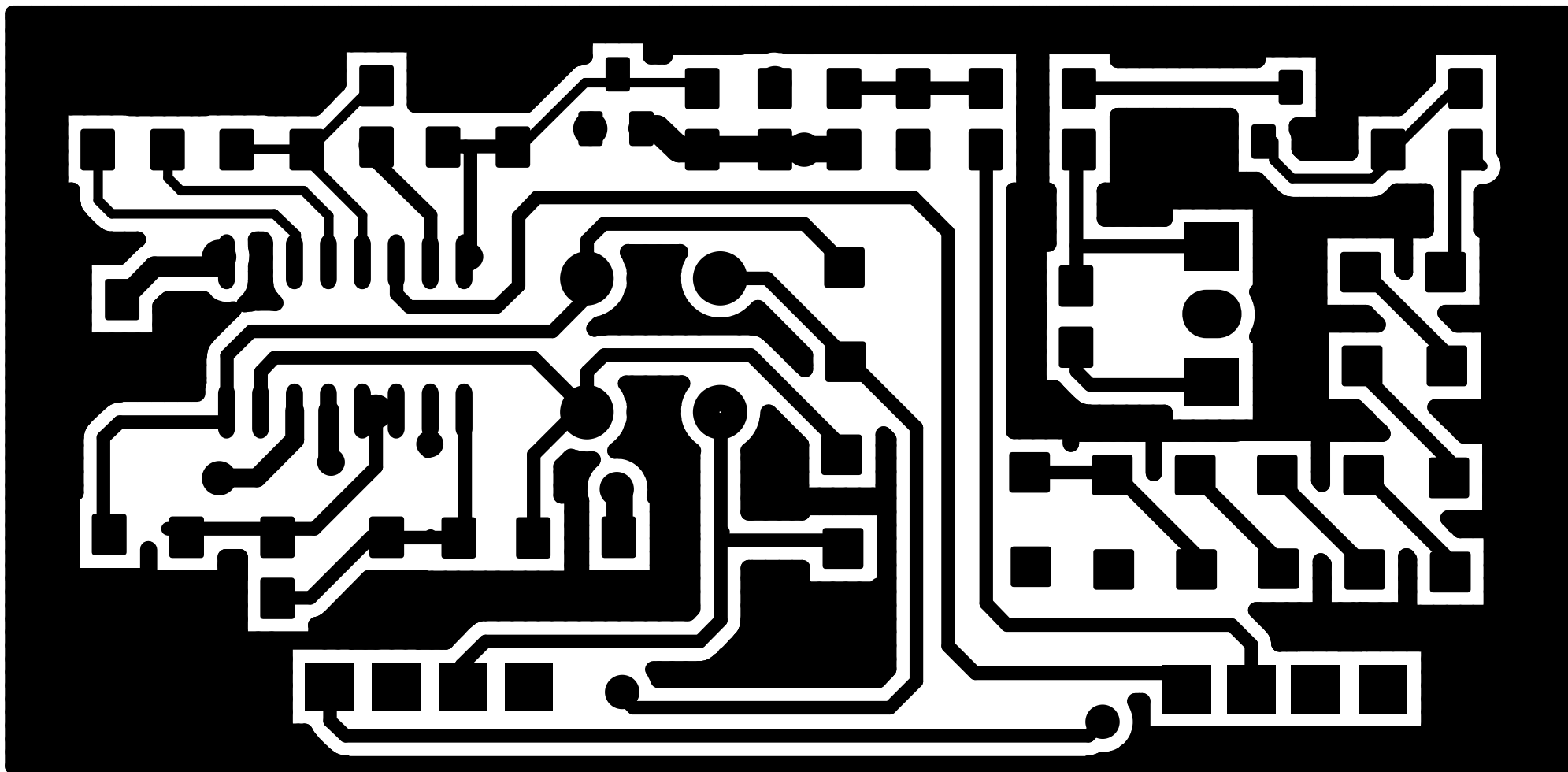

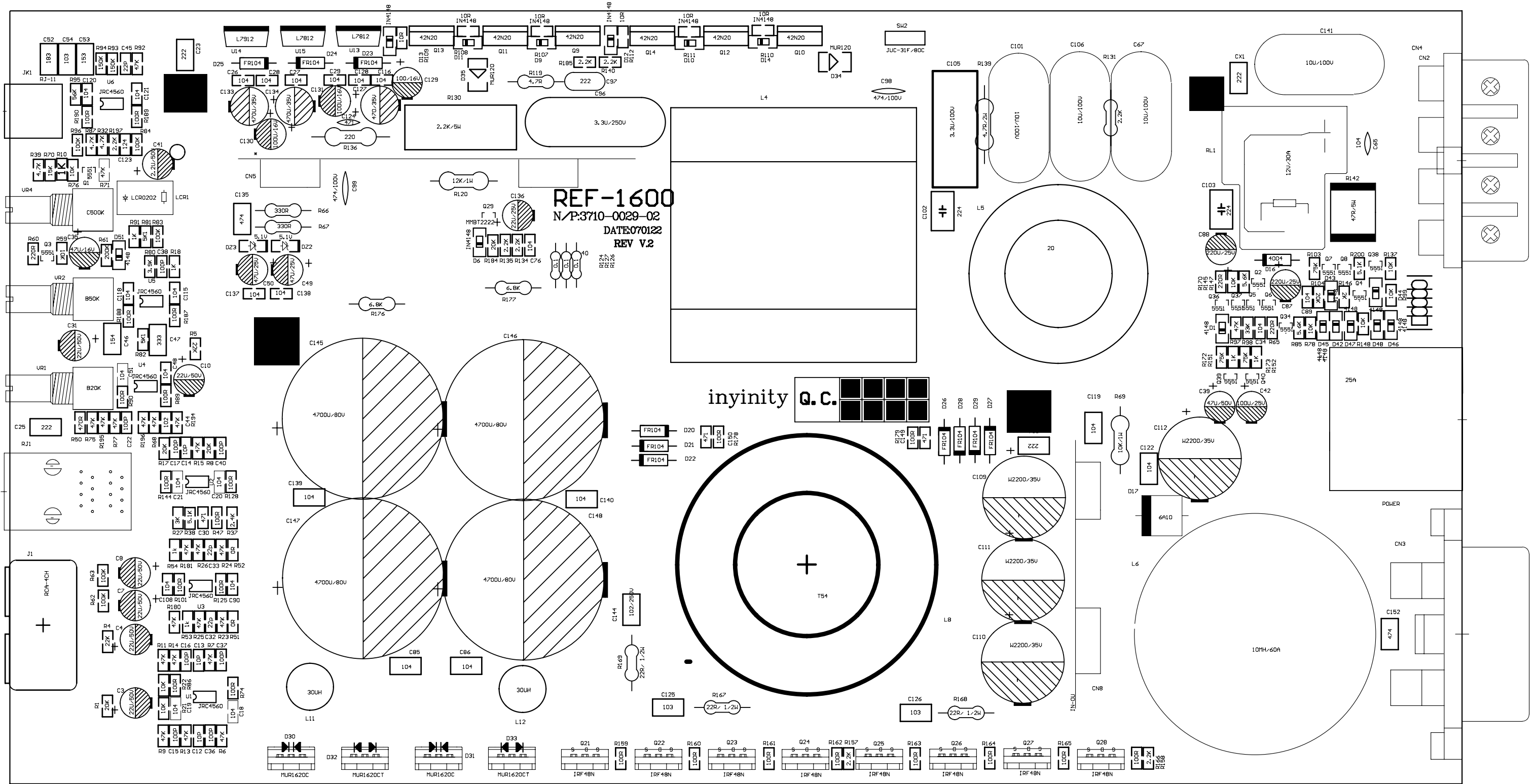

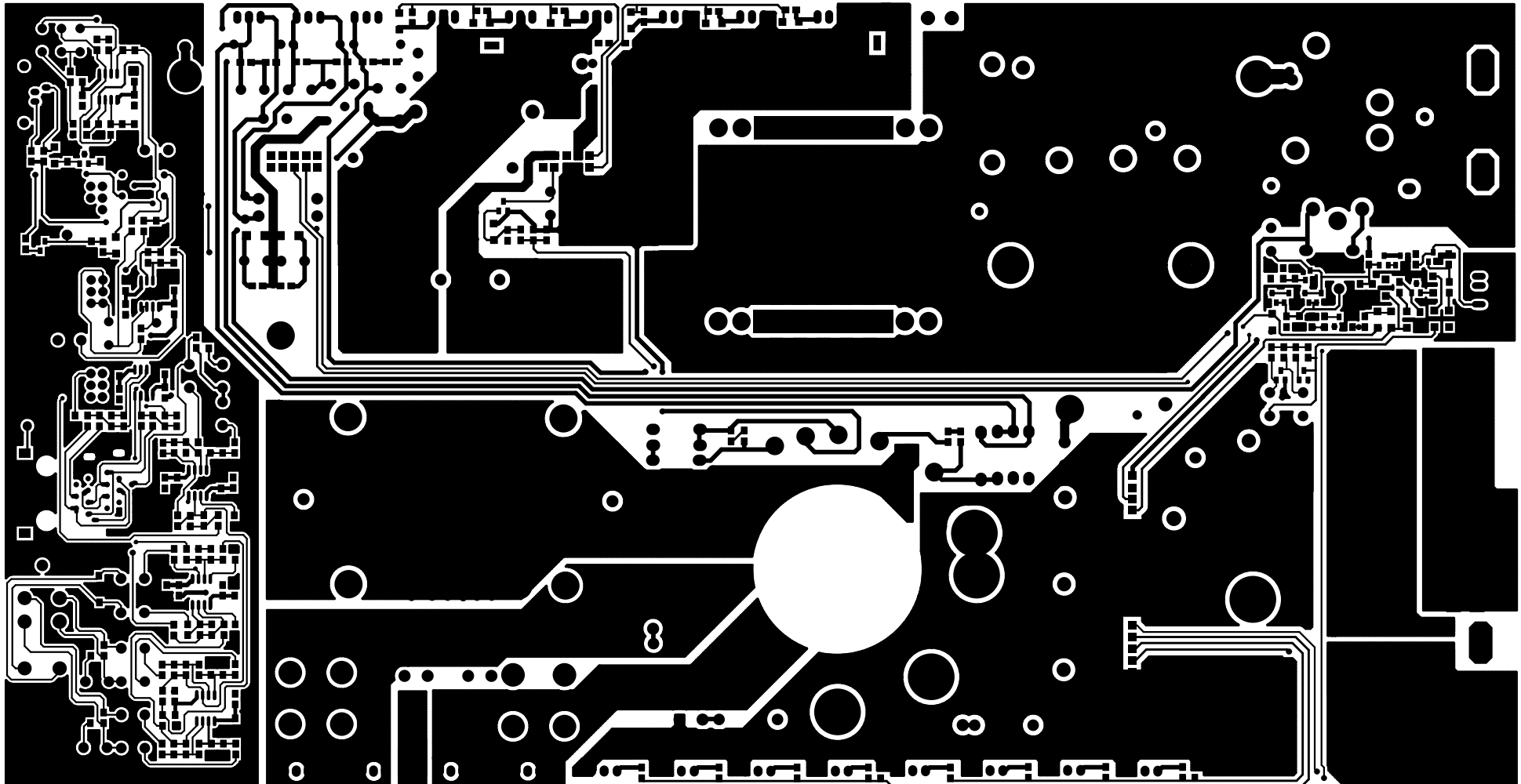

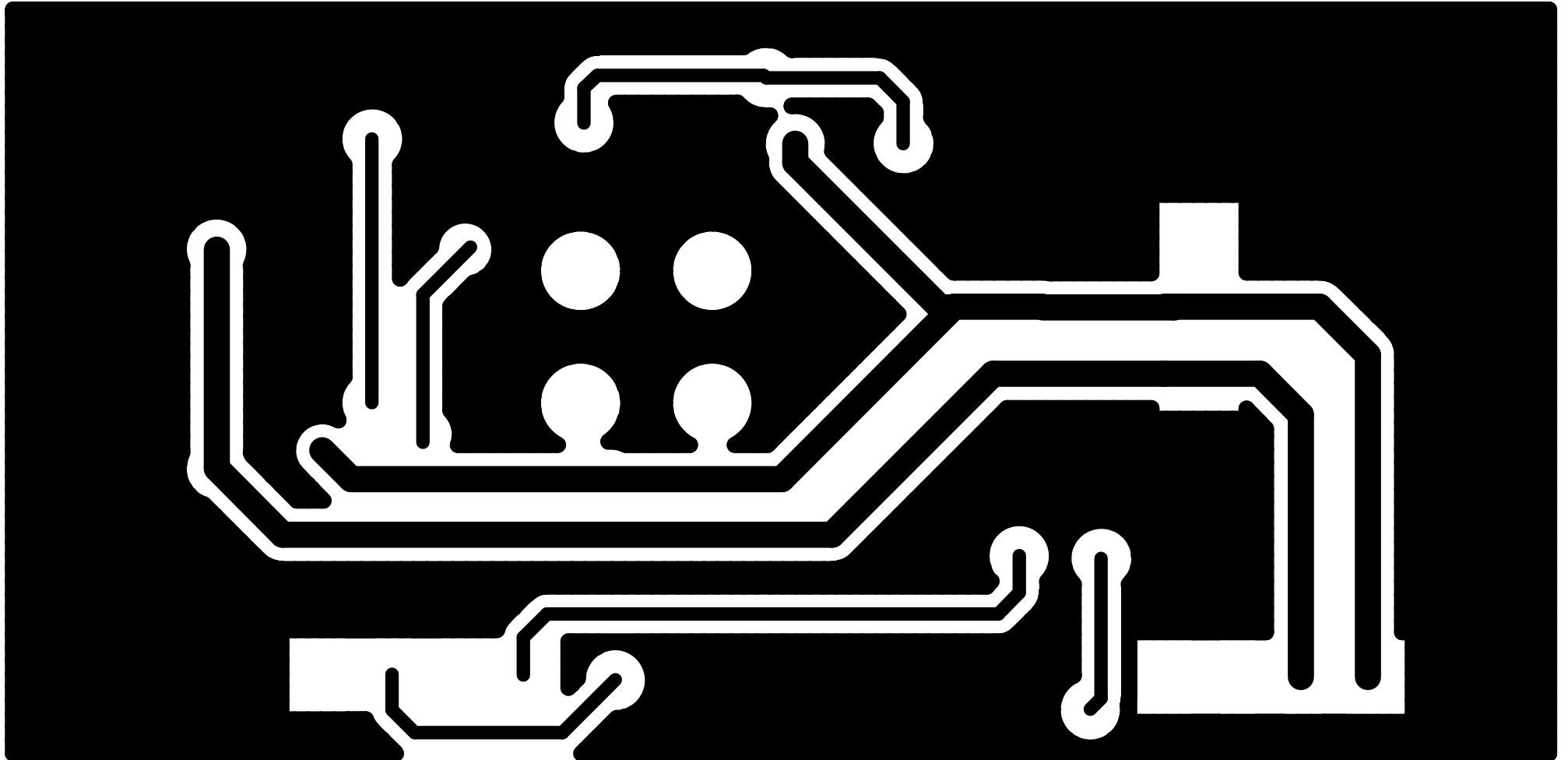

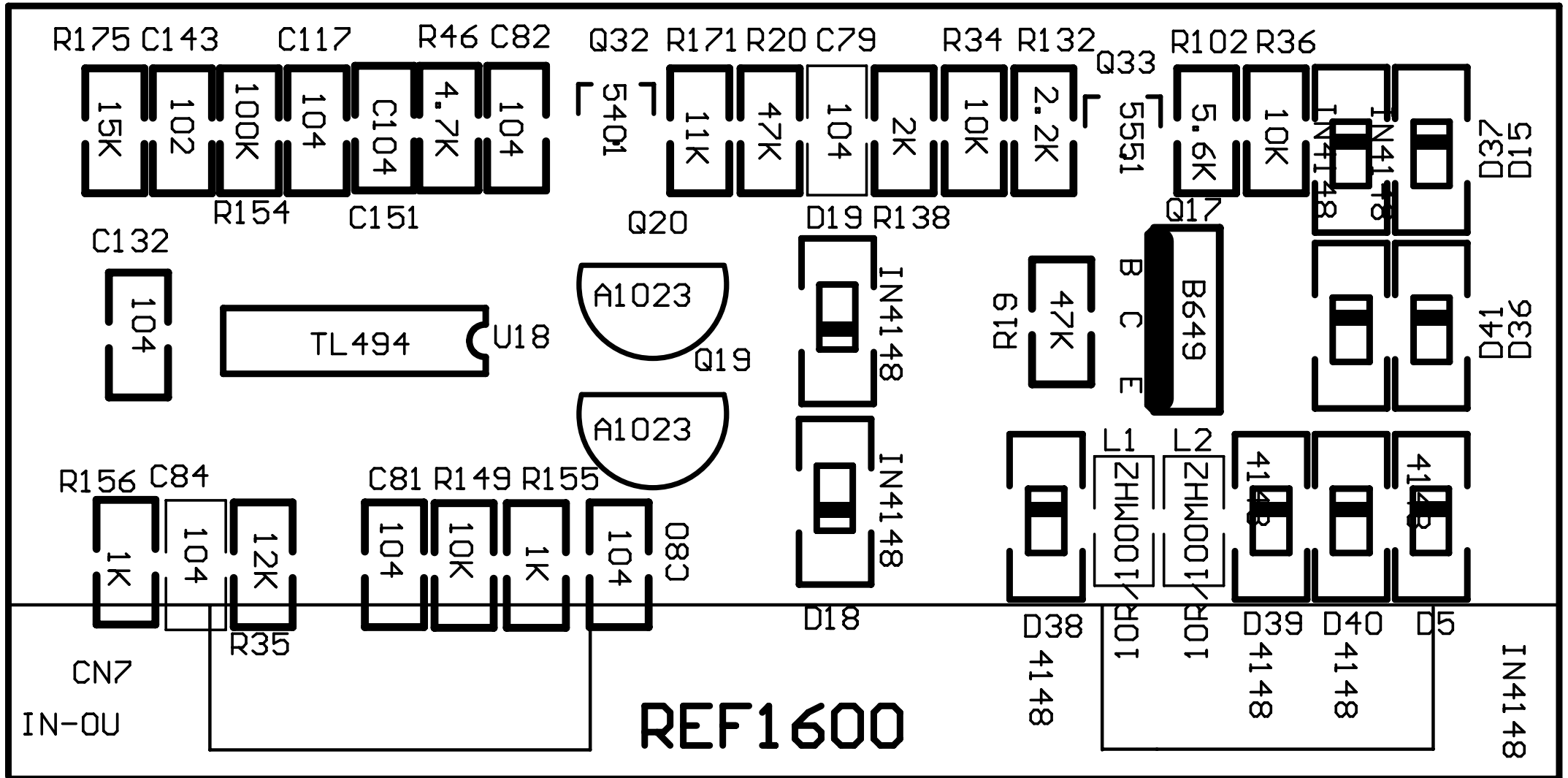

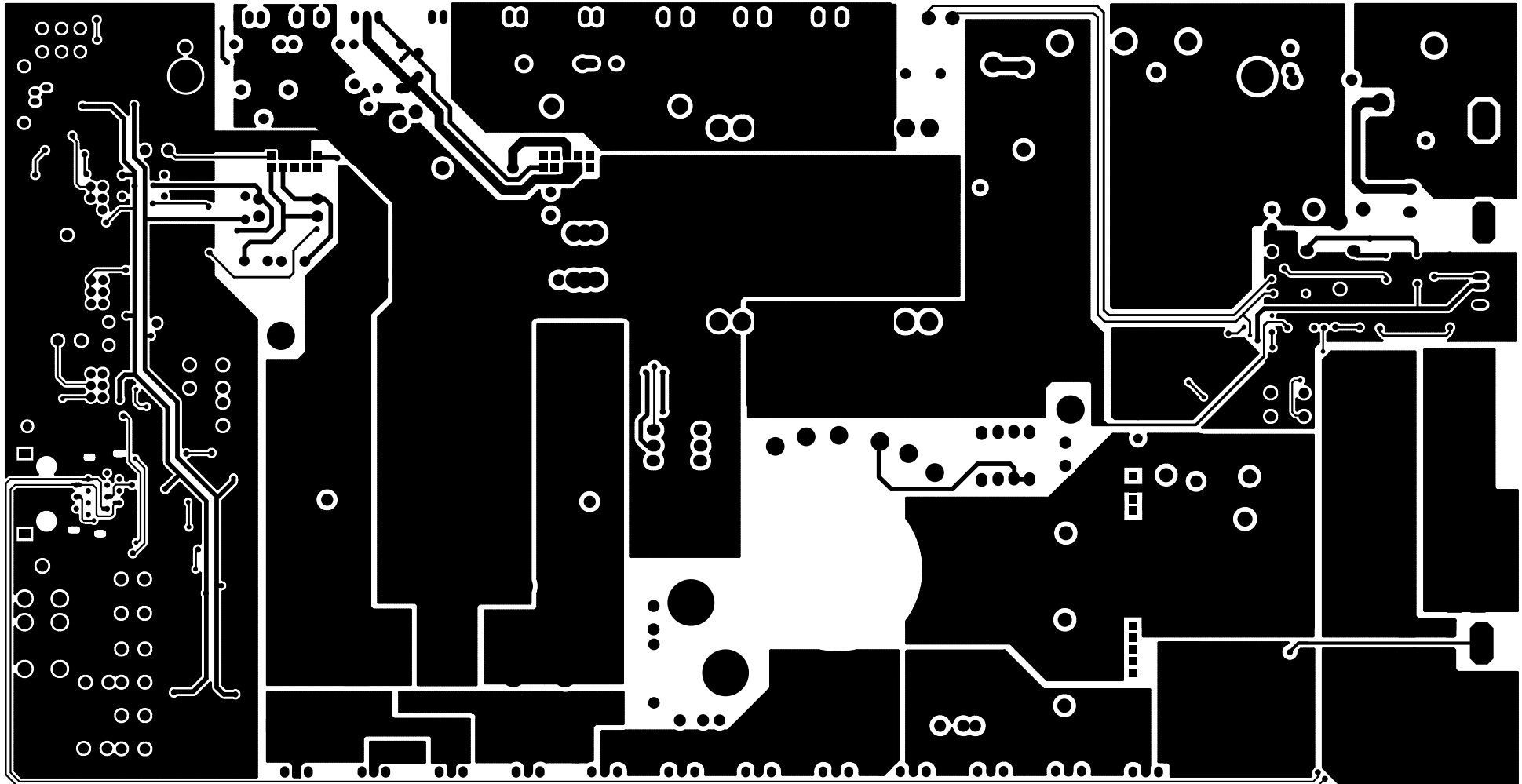

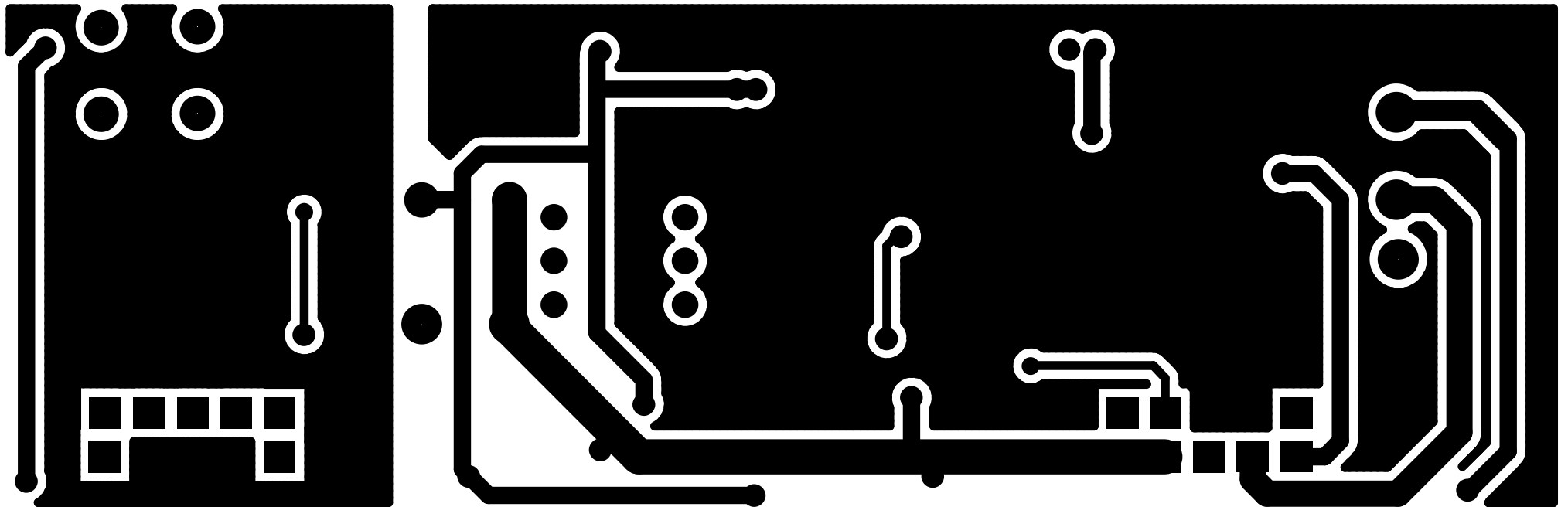

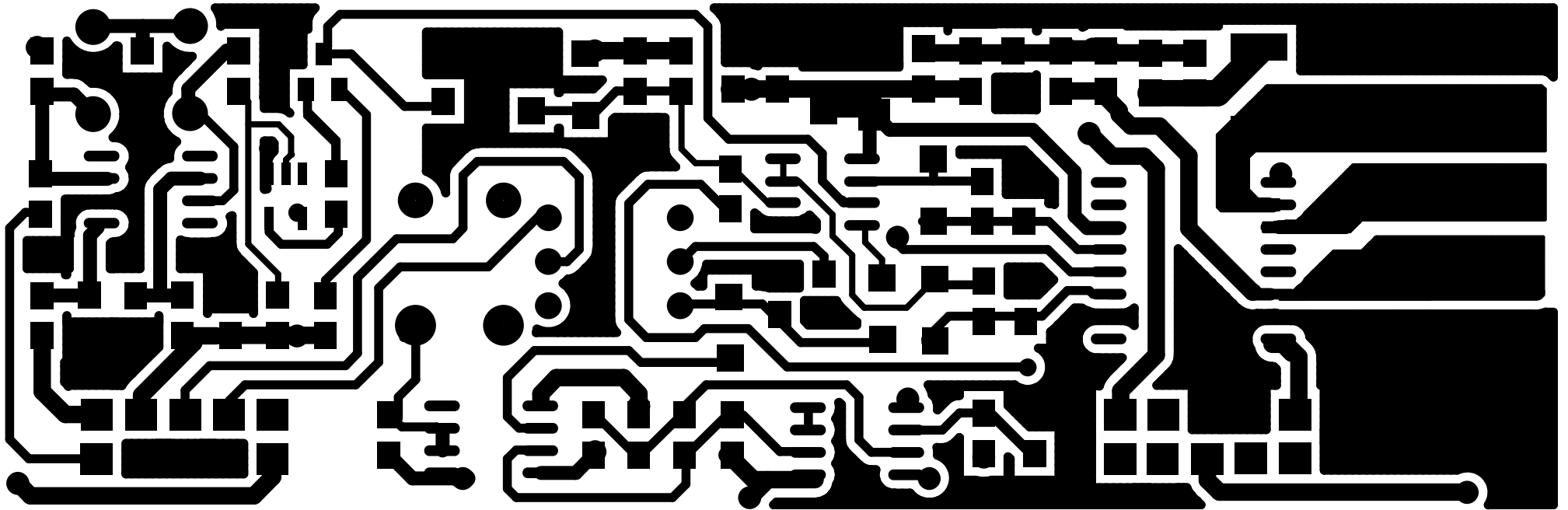

REFERENCE 1600a Electrical Parts List				
Part Number	Description	Qty	Reference Designator	
MAIN BOARD				
<i>Resistors</i>				
0702-0106-03	Resistor	10mΩ ±1% manganin resistor 1.5 0.5MM 16.5MM	3	R127 R126 R124
0701-2000-02	Resistor	SMD 0Ω 1/8W ±5% 0805	2	R52 R51
0702-4103-02	Carbon resistor	1W 10KΩ ±5% TR 15MM	1	R69
0701-2100-02	Resistor	SMD 10Ω 1/8W ±5% 0805	6	R111 R112 R110 R109 R108 R107
0701-2101-02	Resistor	SMD 100Ω 1/8W ±5% 0805	23	R165 R164 R163 R162 R161 R160 R159 R144 R128 R125 R101 R90 R89 R86 R74 R47
0701-2221-02	Resistor	SMD 220Ω ±1/8W 5% 0805	3	R60 R170 R65
0701-2102-02	Resistor	SMD 1KΩ 1/8W ±5% 0805	7	R18 R151 R152 R91 R54 R53 R10
0701-2202-02	Resistor	SMD R0805 2KΩ 1/8W ±5% TR	1	R146
0701-2222-02	Resistor	SMD 2.2KΩ 1/8W ±5% 0805	7	R197 R185 R140 R135 R134 R157 R158
0701-2472-02	Resistor	SMD 4.7KΩ 1/8W ±5% 0805	3	R32 R39 R87
0701-2512-02	Resistor	SMD 5.1KΩ 1/8W ±5% 0805	4	R38 R200 R82 R81
0701-2562-02	Resistor	SMD 5.6KΩ 1/8W ±5% 0805	2	R147 R85
0701-2103-02	Resistor	SMD 10KΩ 1/8W ±5% 0805	9	R76
0701-2153-02	Resistor	SMD 15KΩ 1/8W ±5% 0805	1	R70
0701-2203-02	Resistor	SMD R0805 20KΩ 1/8W ±5% TR	5	R1 R8 R17 R184 R104
0701-2223-02	Resistor	SMD 22KΩ 1/8W ±5% 0805	2	R5 R4
0701-2333-02	Resistor	SMD 33KΩ 1/8W ±5% 0805	1	R98
0701-2473-02	Resistor	SMD 47KΩ 1/8W ±5% 0805	22	R181 R180 R97 R92 R26 R25 R14 R23 R15 R11 R9 R13 R77 R68 R6 R7 R75 R24 R195 R194 R196 R71
0701-2563-02	Resistor	SMD 56KΩ 1/8W ±5% 0805	1	R95
0701-2104-02	Resistor	SMD 100KΩ 1/8W ±5% 0805	5	R63 R62 R84 R83 R96
0701-2154-02	Resistor	SMD 150KΩ 1/8W ±5% 0805	2	R94 R93
0702-3220-02	Carbon resistor	1/2W 22Ω ±5% TR 12.5MM	3	R169 R168 R167
0702-4682-02	Carbon resistor	1W 6.8K ±5% 15mm	2	R176 R177
0702-4123-02	Carbon resistor	1W 12K ±5% 15mm	1	R120
0712-64R7-02	Metalfilm resistor	2W 4.7Ω ±5% 10MM	1	R139
0702-6221-02	Carbon resistor	2W 220Ω ±5% TR 17.5MM	1	R136
0705-5470-02	Resistor	5W 47Ω ±5%	1	R142
0701-2204-02	Resistor	SMD 200KΩ 1/8W ±5% 0805	1	R61
0701-2753-02	Resistor	SMD 75K ±5% 1/8W 0805	1	R103
0702-3331-02	Carbon resistor	1/2W 330Ω ±5% TR 12.5MM	2	R66 R67
0701-2392-02	Resistor	SMD 3.9KΩ 1/8W ±5% 0805	1	R80
0702-34R7-02	Carbon resistor	1/2W 4.7Ω ±5% TR 12.5MM	1	R119
06D1C106C001	Metalfilm resistor	10UF/250V ±10% 13.5*24 25.5mm	4	C141 C67 C106 C101
0703-3222-03	Metalfilm resistor	1/2W 2.2KΩ ±1% TR	1	R131
0702-5222-02	Cement Resistor	5W 2.2K ±5% =25mm	1	R130
0701-2242-02	Resistor	SMD 2.4KΩ 1/8W ±5% 0805	1	R37
0701-2272-02	Resistor	SMD 2.7KΩ 1/8W ±5% 0805	1	R27
0701-2471-02	Resistor	SMD 470Ω 1/8W ±5% 0805	1	R50
0701-1753-02	Resistor	SMD 75KΩ 1/10W ±5% 0603	2	R172 R173
1204-5041-05	Potentiometer	9MM R0971G C500K KQL=15MM T=7.5MM M=1MM ±10% BASS BOOST	1	VR4
1204-5031-30	Potentiometer	B50K ±10% KQ LP FREQ.	1	VR2
1201-2031-02	Potentiometer	A20K KQ L=15mm LEVEL	1	VR1
<i>Capacitors</i>				
06S121046000	Capacitor	SMD 0.1uF/50V 0805 X7R ±10%	23	C138 C137 C121 C120 C118 C115 C108 C90 C89 C76 C51 C48 C34 C29 C28 C27 C26 C21 C20 C19 C18 C116 C128
06S124716000	Capacitor	SMD 470pF/50V 0805 X7R ±10%	3	C150 C149 C30
06S321026000	Capacitor	SMD 1000pF/50V 0805 NPO ±5%	1	C44
06S321016000	Capacitor	SMD 100pF/50V 0805 NPO ±5%	8	C17 C40 C22 C16 C36 C37 C15 C38

Part Number	Description		Qty	Reference Designator
MAIN BOARD				
06S322206000	Capacitor	SMD 22pF/50V 0805 NPO ±5%	3	C45 C33 C32
06S321006000	Capacitor	SMD 10pF/50V 0805 NPO ±5%	3	C12 C13 C14
06D342227400	MET capacitor	(BOX)222/100V ±5% Yellow TR	5	C25 CX1 C97 C23 C24
06D374717400	Tan capacitor	470pF/100V ±5% 5.5mm TR	1	C124
06D241546000	MET capacitor	0.15UF/50V ±20% TR 5mm	1	C46
06D324747700	metallized Capacitor	474J/100V 5*11MM ±5% Brown TR 5MM	2	C135 C152
06D1C4747701	Metafilm resistor	474/100V ±10% Brown TR 7.5mm	2	C98 C99
06D321047200	Terylene capacitor	104/100V ±5% Green TR 5MM	7	C122 C65 C119 C85 C86 C139 C140
06D341537400	MET capacitor	153/100V ±5% 5MM TR	1	C53
06D22102C000	MET capacitor	102/250V TR 5mm ±20%	1	C144
06D342247400	MET capacitor	224/100V ±5% TR 5MM	2	C103 C102
06D341839400	MET capacitor	183/63V ±5% Yellow 5MM	1	C52
06D343339400	MET capacitor	333/63V ±5% TR 5MM	1	C47
06D341039000	MET capacitor	103/63V ±5% TR 5mm	3	C54 C125 C126
06D2C3357700	Metafilm resistor	3.3UF/100V ±20% 105°C Brown 20.5mm	1	C105
06D2C335C700	Metafilm resistor	3.3UF/250V ±20% 105°C Brown 27mm	1	C96
06D212264102	E-capacitor	22uF/25V ±20% 5*11 105°C Black 5MM TR	1	C136
06D211074100	E-capacitor	100uF/25V ±20% 6.3*11 105°C Black 5MM TR	4	C129 C131 C130 C42
06D212264103	E-capacitor	220uF/25V ±20% 8*12 105°C Black 5MM TR	2	C88 C87
06D214764102	E-capacitor	47uF/25V ±20% 5*11 105°C Black 5MM TR	3	C50 C49 C35
06D214775101	E-capacitor	470UF/35V ±20% Φ8*20MM 105°C Black	3	C134 C133 C127
06D212285101	E-capacitor	2200UF/35V Φ16*26MM ±20% 105°C 7.5MM	4	C112 C111 C110 C109
06S121244000	Capacitor	SMD 0.12UF/25V 0805 X7R ±10%	1	C123
06D212256301	E-capacitor	2.2UF/50V ±20% 5*11 105°C Orange 5mm TR	1	C41
06D21478H001	E-capacitor	4700UF/80V ±20% 105°C 35*30mm 10.5mm	4	C145 C146 C147 C148
06D212266010	E-capacitor	22uF/50V ±20% 5*11 105°C TR 5.0MM	6	C3 C4 C7 C8 C10 C31
06D214766001	E-capacitor	47uF/50V ±20% 6.3*11 105°C TR 5MM	1	C39
<i>Semiconductors</i>				
04GS-R104-00	High speed diode	FR104 1A 400V 52MM TR	10	D29 D28 D27 D26 D25 D24 D23 D22 D21
04ZL-4004-03	Diode	IN4004 DO-41 TR	1	D16
04WY-51AV101	Zener diode	SMD 5.1V DO-213AA 0.5W	2	DZ3 DZ2
04PT-4148-01	Diode	SMD 1N4148 DO-213AA	16	D43 D51 D44 D46 D45 D48 D47 D6 D1 D14 D13 D12 D11 D10 D9 D42
04ZL-2512-00	Diode	SMD MUR120 1A 2512	2	D35 D34
04ZL-6A10-00	Diode	6A10 1000V	1	D17
03T1-Z48N-02	MOS FET	IRFZ48N TO-220	8	Q28 Q27 Q26 Q25 Q24 Q23 Q22 Q21
03N1-5551-04	Transistor	SMD MMBT5551LT1 NPN SOT-23	14	Q38 Q40 Q1 Q4 Q39 Q37 Q36 Q8 Q7 Q6 Q5 Q2 Q3 Q34
03N1-2222-04	Transistor	SMD BT2222 NPN SOT-23	1	Q29
03D1-38N2-02	MOS FET	IRFB 38N20D TO-220	6	Q14 Q13 Q12 Q11 Q10 Q9
01FA-7912-04	Regulator	KA7912 TO-220 FAIRCHILD	1	U14
01JR-4560-08	IC	DIP NJM4560D Dual Op-amp DIP-8	6	U6 U5 U4 U3 U2 U1
2601-0202-00	Optocoupler	LCR-0202	1	LCR1
2202-1620-05	Rectifier	MUR1620CTA KAD 16A/200V TO-220	2	D33 D32
2202-1602-05	Rectifier	UF1602CT AKA 16/200V TO-220	2	D31 D30
01FA-7812-04	Regulator	KA7812E TO-220 FAIRCHILD	2	U13 U15
<i>Miscellaneous</i>				
1400-0001-16	RJ45 Jack	16PIN RJ45 2*10P16C	1	RJ1
3000-INIT-03	HF transformer	φ47 4:19:8:6 L1=L2=φ1.0*8*4TS S1=S2=φ0.8*6*19TS S3=S4=φ1.0*1*8TS S5=S6=φ1.0*1*6TS	1	L8
1380-0209-00	Temperature switch	80°C±5°C TO-220 PIN 2PCS	1	SW2
1500-0400-01	Terminal	Golden crosshead screw	1	
1500-0300-01	Terminal	Golden crosshead screw	1	
2901-224C-00	Relay	DC12V 30A	1	RL1
1004-3000-10	HF bead	30UH φ12 φ5 11.5mm	2	L12 L11
1502-0504-00	Jack	Pitch 2.0MM 5PIN Bend 90degree	1	CN1

Part Number	Description		Qty	Reference Designator
MAIN BOARD				
1001-1015-10	Common mode choke	5MU 60A ϕ 47 22mm*18mm	1	L6
1001-4000-10	Inductor	40UH 40A core:ETD-49 ϕ 0.1*80*14TS	1	L4
1001-3001-10	HF inductor	35UH ϕ 25 ϕ 0.3*20*2	1	L4
1413-0001-00	Phone Jack	6P4C RJ11 Black	1	JK1
1404-0004-00	RCA Jack	4 Jacks white red golden	1	J1
1401-0001-03	Fuse holder	3PIN	1	for F1
1601-253G-00	Fuse	25A/32V	6	F1
POWER BOARD				
0701-2104-02	Resistor	SMD 100K Ω 1/8W \pm 5% 0805	1	R154
0701-2113-02	Resistor	SMD 11K Ω 1/8W \pm 5% 0805	1	R171
0701-2153-02	Resistor	SMD 15K Ω 1/8W \pm 5% 0805	1	R175
0701-2222-02	Resistor	SMD 2.2K Ω 1/8W \pm 5% 0805	1	R132
0701-2472-02	Resistor	SMD 4.7K Ω 1/8W \pm 5% 0805	1	R46
0701-2432-02	Resistor	SMD 4.3K Ω 1/8W \pm 5% 0805	1	R102
0701-2103-02	Resistor	SMD 10K Ω 1/8W \pm 5% 0805	3	R149 R36 R34
0701-2123-02	Resistor	SMD 12K Ω 1/8W \pm 5% 0805	1	R35
0701-2102-02	Resistor	SMD 1K Ω 1/8W \pm 5% 0805	2	R155 R156
0701-2202-02	Resistor	SMD R0805 2K Ω 1/8W \pm 5% TR	1	R138
0701-2473-02	Resistor	SMD 47K Ω 1/8W \pm 5% 0805	2	R19 R20
0701-2623-02	Resistor	SMD 62K Ω 1/8W \pm 5% 0805	1	R12
06S321046000	E-capacitor	SMD 0.1 μ F/50V 0805 NPO \pm 5%	1	C1
06S321026000	Capacitor	SMD 1000pF/50V 0805 NPO \pm 5%	1	C143
06S321046000	Capacitor	SMD 0.1 μ F/50V 0805 NPO \pm 5%	8	C79 C81 C82 C84 C117 C132 C80 C151
1003-1010-08	Inductor	SMD 100MH 100MHZ 4A	2	L1 L2
04PT-4148-01	Diode	SMD 1N4148 DO-213AA	10	D18
03N1-5551-04	Transistor	SMD MMBT5551LT1 NPN SOT-23	1	Q33
03P1-5401-04	Transistor	SMD MMBT5401LT1 PNP SOT-23	1	Q32
03P1-1023-01	Transistor	DIP 2SA1023 TO-92 PNP TR	2	Q19 Q20
03P1-B649-07	Transistor	DIP 2SB649A 1.5A 180V 20W PNP TO-126	1	Q17
01TI-L494-09	IC PWM	SMD TL494C SO-16	1	U18
1501-0509-04	Clubfoot pin	DIP PITCH 2.54mm 5PIN Bend 90 degree	1	CN7
1501-0409-02	Clubfoot pin	DIP PITCH 2.54mm 4PIN Bend 90 degree	1	
LED BOARD				
2004-0017-00	LED	ϕ 3 White with blue light	8	
2100-0035-05	FFC	5PIN 2.0 UL1007 28AWG L=100mm 2.0 105 $^{\circ}$ C	1	
2000-0017-00	LED	DIP Red with red lighth Φ 3MM 2P	1	LED101
2004-0014-00	LED	DIP Φ 3.0MM Blue with blue light	1	LED100
0701-6102-02	Resistor	SMD 1K Ω 1/2W \pm 5% 2010	2	
2102-0153-02	FFC	2PIN UL1007 red black 28AWG L=320mm 5mm	1	
2102-0154-02	FFC	2PIN UL1007 red black 28AWG L=40mm 5mm	1	
1502-0504-00	Jack	DIP Pitch 2.0MM 5PIN Bend 90 degree	1	
06S121046000	Capacitor	SMD 0.1 μ F/50V 0805 X7R \pm 10%	2	C1 C2
04PT-4148-01	Diode	SMD 1N4148 DO-213AA	2	D1 D2
SIGNAL BOARD				
<i>Resistors</i>				
0701-2104-02	Resistor	SMD 100K Ω 1/8W \pm 5% 0805	1	R64
0701-2103-02	Resistor	SMD 10K Ω 1/8W \pm 5% 0805	4	R3 R33 R30 R31
0701-2100-02	Resistor	SMD 10 Ω 1/8W \pm 5% 0805	4	R117 R118 R193 R198
0701-2102-02	Resistor	SMD 1K Ω 1/8W \pm 5% 0805	2	R55 R58
0701-2222-02	Resistor	SMD 2.2K Ω 1/8W \pm 5% 0805	2	R105 R106
0701-2203-02	Resistor	SMD R0805 20K Ω 1/8W \pm 5% TR	1	R2
0701-2472-02	Resistor	SMD 4.7K Ω 1/8W \pm 5% 0805	5	R40 R41 R42 R43 R44
0701-2431-02	Resistor	SMD 430 Ω \pm 5% 1/8W 0805	1	R45

Part Number	Description		Qty	Reference Designator
SIGNAL BOARD				
0701-2681-02	Resistor	SMD 680Ω 1/8W ±5% 0805	2	R116 R199
0701-2152-02	Resistor	SMD 1.5KΩ 1/8W ±5% 0805	1	R56
0701-2101-02	Resistor	SMD 100Ω 1/8W ±5% 0805	3	R49 R191 R192
0701-2303-03	Resistor	SMD 30K 1/8W ±1% 0805	1	R29
0701-2221-02	Resistor	SMD 220Ω ±1/8W 5% 0805	1	R113
0701-2331-02	Resistor	SMD 330Ω 1/8W ±5% 0805	1	R48
0701-2473-02	Resistor	SMD 47KΩ 1/8W ±5% 0805	1	R57
<i>Capacitors</i>				
06D211076100	E-capacitor	DIP 100uF/50V ±20% 6.3*11 105°C BIK 5MM	2	C93 C94
06S321026000	Capacitor	SMD 1000pF/50V 0805 NPO ±5%	1	C100
06S321016000	Capacitor	SMD 100pF/50V 0805 NPO ±5%	2	C61 C62
06S321046000	Capacitor	SMD 0.1uF/50V 0805 NPO ±5%	8	C57 C59 C60 C63 C75 C77 C91 C92
06S132253000	ceramic capacitor	SMD 2.2uF/16V 1206 X7R ±10%	2	C104 E1
06D344727400	MET Capacitor	DIP 472/100V ±5% TR 5MM	2	C55 C56
06S123326000	Capacitor	SMD 332/50V ±10% X7R 0805	1	C64
06D214764102	E-capacitor	DIP 47uF/25V ±20% 5*11 105°C Black 5MM TR	1	C43
06D211074100	E-capacitor	DIP 100uF/25V ±20% 6.3*11 105°C BIK 5MM	1	C58
<i>Semiconductors</i>				
0100-C081-08	IC	TLC081 SOP-8 Op-Amp	1	U8
2601-4N35-00	Optocoupler	4N35 DIP6	1	U17
01LM-M555-08	IC	SMD LM555 Timer SOP-8	1	U7
0100-74AH-00	IC	74AHC1G04 Inverter SOT-235	1	U16
0100-2010-00	IC	IR2010S High/Low side driver SOL-16	1	U10
03P1-5401-04	Transistor	SMD MMBT5401LT1 PNP SOT-23	1	Q30
01TC-WH04-00	IC	TC7WH04F Triple Inverter	1	U9
04ZL-2512-00	Diode	SMD MUR120 1A 2512	1	D8
01LM-M311-08	IC	SMD LM311 Comparator SOP-8	1	U11
04PT-4148-01	Diode	SMD 1N4148 DO-213AA	5	D2 D3 D4 D7 D49
04WY-51AV101	Zener diode	SMD 5.1V DO-213AA 0.5W	1	DZ1
<i>Miscellaneous</i>				
1505-1009-04	Clubfoot pin	DIP PITCH 2.54mm 10PIN Bend 90 degree	2	CN6
MECHANICAL				
ZL-A0001A-15	6.5PC Pole	φ7.5*φ3.0*6.4mm LASK-5	2	
PL-L0007-000	Cliper	30*36*0.8mm	1	
PL-L0006-000	Cliper	30*28*0.8mm	10	
JY222A18A01X	Mica	22*18*0.1MM	1	
JY233A22A001	Mica	33*22*0.1mm	1	
JY297A22A001	Mica	97*22*0.1mm	1	
JY264A22A001	Mica	64*22*0.1mm	1	
JY242A22A001	Mica	42*22*0.1mm	1	
ZA-H00040100	Snap button	φ7.5 M3.5*4	4	
LS1AM0250401	Screw	Plating black zinc 2.5*4	4	
JY217A12A10A	ceramic plate	17*12*1.0mm white	6	
LS1AA0301501	Screw	PA3*15 plating black zinc	2	
LS1FJ0200801	Screw	KA2*8 plating black zinc	2	
LS5KJ0301007	Screw	3*10MM Plating nickel	3	
LS5KP0300807	Screw	3*8MM Plating nickel	8	
LS1AP0300607	Screw	3*6MM Plating nickel	6	
LS1AM0300607	Screw	PM3*6 Plating nickel	2	
KT-200012200	CAP	White PVC for RCA	2	
KT-200021300	CAP	Red PVC for RCA	2	
LS1AY0301201	Screw	PM3*12MM plating zinc	4	
XG-0017-2601	Bottom plate	325*182*1.2mm, H1-144 silver painting	1	

Part Number	Description		Qty	Reference Designator
MECHANICAL				
HG-0005-2601	Rear plate	214*70*1.2mm, H1-144 silver painting with silkscreen	1	
MK-0004-2601	Front plate	214*70*1.2mm, H1-144 silver painting with silkscreen	1	
KG-100100500	Snap button	T07-003-01 ϕ 11* ϕ 14*10.8 Black ABS	4	
LS1AA0200501	Screw	PA2*5 Black zinc	1	
LS1FM0300011	Screw	KM 3*6MM Black zinc	5	
CP-B00011400	Lens	40*10.8*5.7mm PC plastic cold grey10C	1	
GD-600011400	Reflector board	270*53.5*13mm clear blue PC plastic	1	
SG-0016-2601	Top plate	360*227*62mm dia- casting aluminum alloy, H1-144 silver painting with silkscreen	1	
SR-1600-0117	Heatsink	325*216*59mm Alum. Hair with painting	1	
BA-20001-000	wire harness	Φ 3*100MM White	1	
DQ8069032084	Washer	Φ 6.9* Φ 3.2*0.8MM	3	
JD-A01970515	Round mat	Φ 5.0*2.0 Black EVA One side with glue	6	

Semiconductor Pinouts

NJM4560 Op-Amp
U1-U6

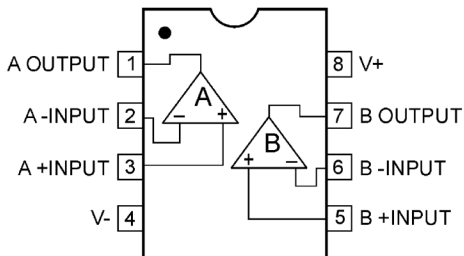

TL494 PWM
U18

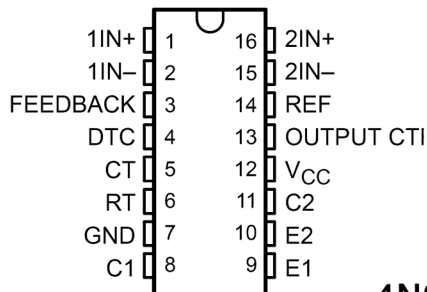

LCR0202
LCR1

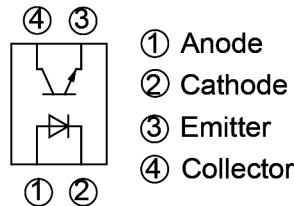

UF1602CT
Rectifier
D31,31



IRFB42N20D MOSFET
IRFZ48N MOSFET
Q9-Q14
Q21-28

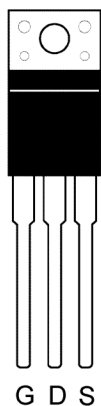

TLC081
Op-Amp U8

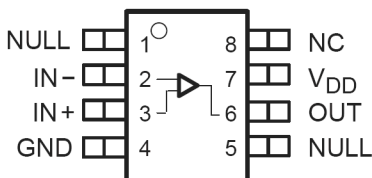

4N35 U17

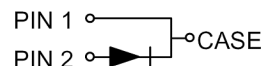
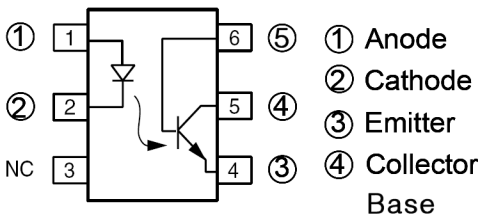

MUR1620CT
Rectifier
D32,33

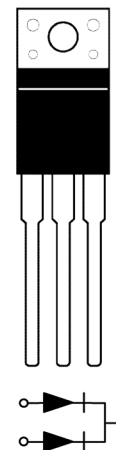

LM311 Comparator
U11

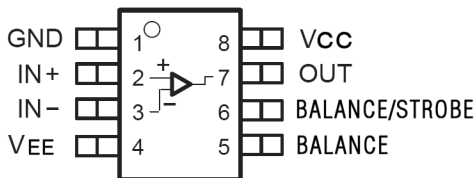

TC7WH04F
Triple Inverter U9

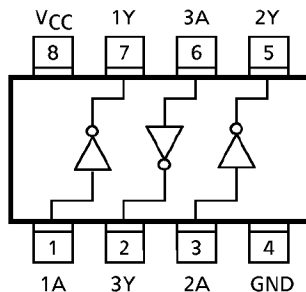

LM555 TIMER
U7

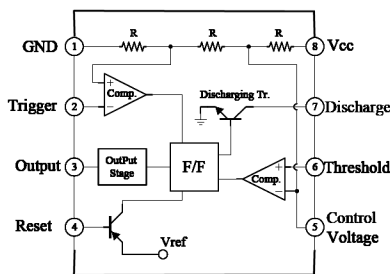

MMBT5401 SOT23,
MMBT5551 SOT23,
MMBT2222 SOT23,

Q1-Q8, Q29,
Q30, Q32-Q34,
Q36-Q40

- 1) Emitter
- 2) Base
- 3) Collector

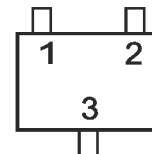

KA7812
+12 REG
U13,15

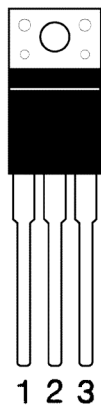

- 1. IN
- 2. GROUND
- 3. OUT

KA7912
-12 REG
U14

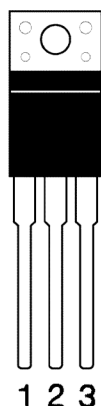

- 1. GROUND
- 2. IN
- 3. OUT

2SB649A
Q17



- 1. Emitter
- 2. Collector
- 3. Base

74AHC1G04 SOT-235
INVERTER U16

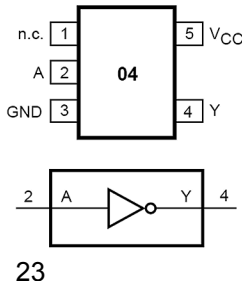

2SA1023 PNP
Q19,20

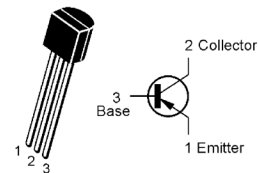

International IR Rectifier

Data Sheet No. PD60195-D

IR2010(S) & (PbF)

HIGH AND LOW SIDE DRIVER

Features

- Floating channel designed for bootstrap operation
Fully operational to 200V
Tolerant to negative transient voltage, dV/dt immune
- Gate drive supply range from 10 to 20V
- Undervoltage lockout for both channels
- 3.3V logic compatible
Separate logic supply range from 3.3V to 20V
Logic and power ground $\pm 5V$ offset
- CMOS Schmitt-triggered inputs with pull-down
- Shut down input turns off both channels
- Matched propagation delay for both channels
- Outputs in phase with inputs
- Also available LEAD-FREE

Product Summary

V_{OFFSET}	200V max.
$I_{O+/-}$	3.0A / 3.0A typ.
V_{OUT}	10 - 20V
$t_{on/off}$	95 & 65 ns typ.
Delay Matching	15 ns max.

Applications

- Audio Class D amplifiers
- High power DC-DC SMPS converters
- Other high frequency applications

Description

The IR2010 is a high power, high voltage, high speed power MOSFET and IGBT drivers with independent high and low side referenced output channels, ideal for Audio Class D and DC-DC converter applications. Logic inputs are compatible with standard CMOS or LSTTL output, down to 3.0V logic. The output drivers feature a high pulse current buffer stage designed for minimum driver cross-conduction. Propagation delays are matched to simplify use in high frequency applications. The floating channel can be used to drive an N-channel power MOSFET or IGBT in the high side configuration which operates up to 200 volts. Proprietary HVIC and latch immune CMOS technologies enable ruggedized monolithic construction.

Packages

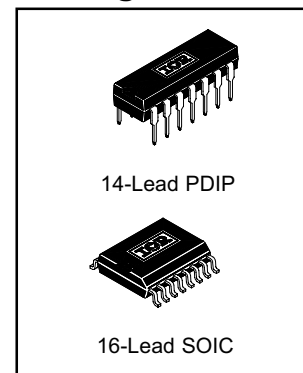

Typical Connection

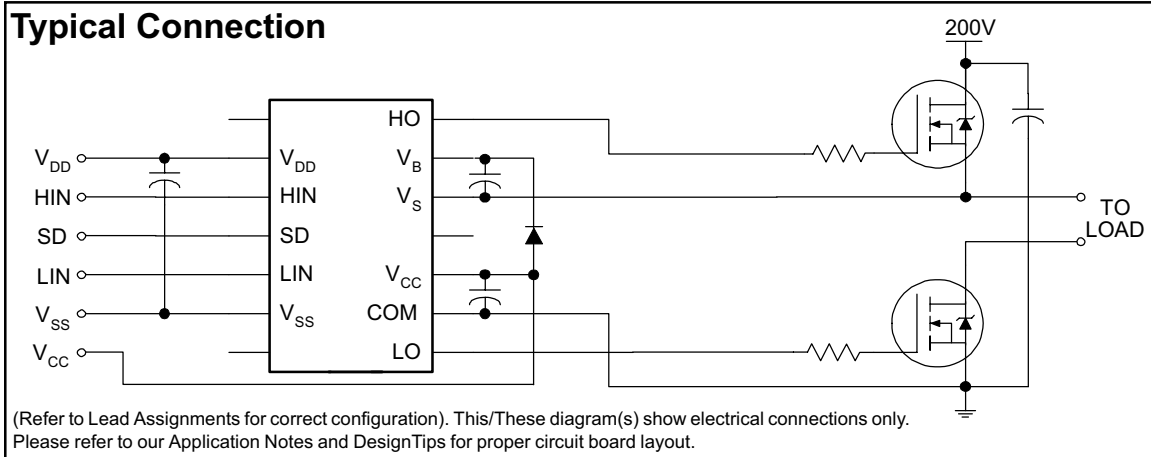

IR2010(S) & (PbF)

International
IR Rectifier

Functional Block Diagram

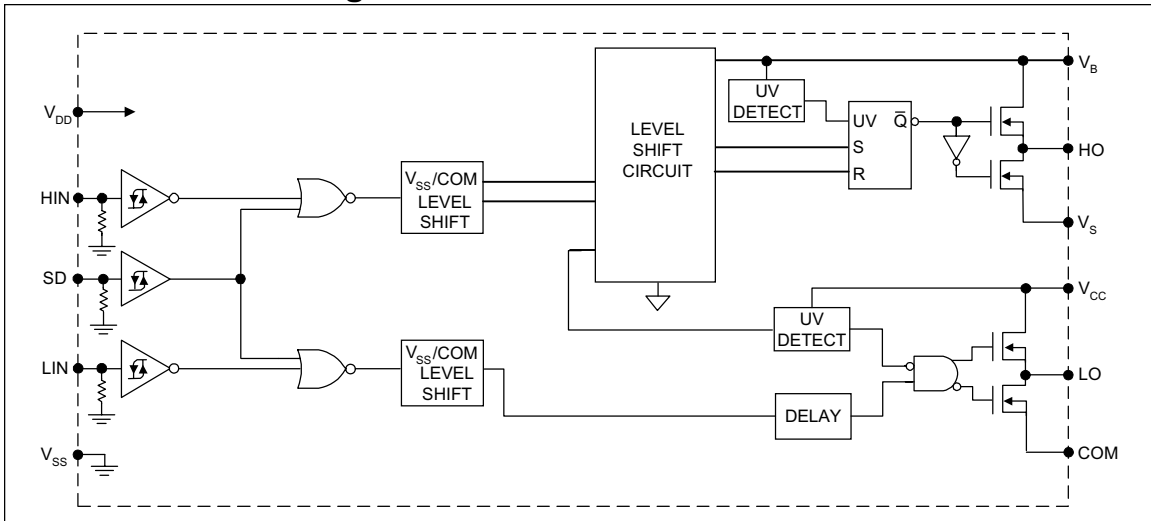

Lead Definitions

Symbol	Description
V _{DD}	Logic supply
HIN	Logic input for high side gate driver output (HO), in phase
SD	Logic input for shutdown
LIN	Logic input for low side gate driver output (LO), in phase
V _{SS}	Logic ground
V _B	High side floating supply
HO	High side gate drive output
V _S	High side floating supply return
V _{CC}	Low side supply
LO	Low side gate drive output
COM	Low side return

Lead Assignments

<p>14 Lead PDIP</p>	<p>16 Lead SOIC (Wide Body)</p>
IR2010	IR2010S
Part Number	

1600a Reference Series

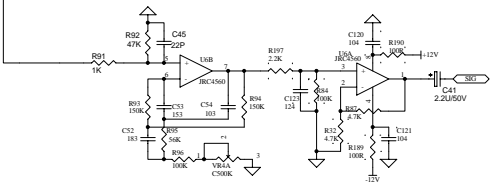
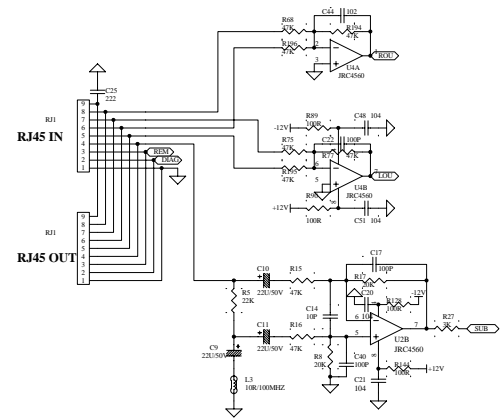
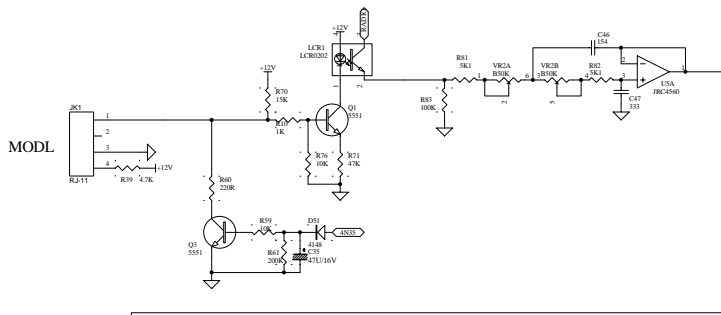
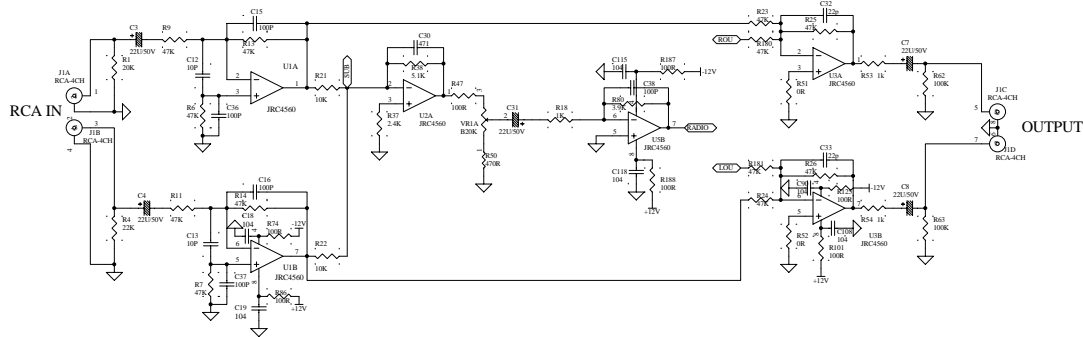

ECN NO	DESCRIPTION	APPROVED	DATA	DW GNS	
				PART NAME:	SCALE: 1:1
				UNIT: MM	DRAWN BY:
				PRODUCT MGR:	CHECKED BY:
				INFINITY REF: 1600	REV: 20
				DATE:	DATE:

1600a Reference Series

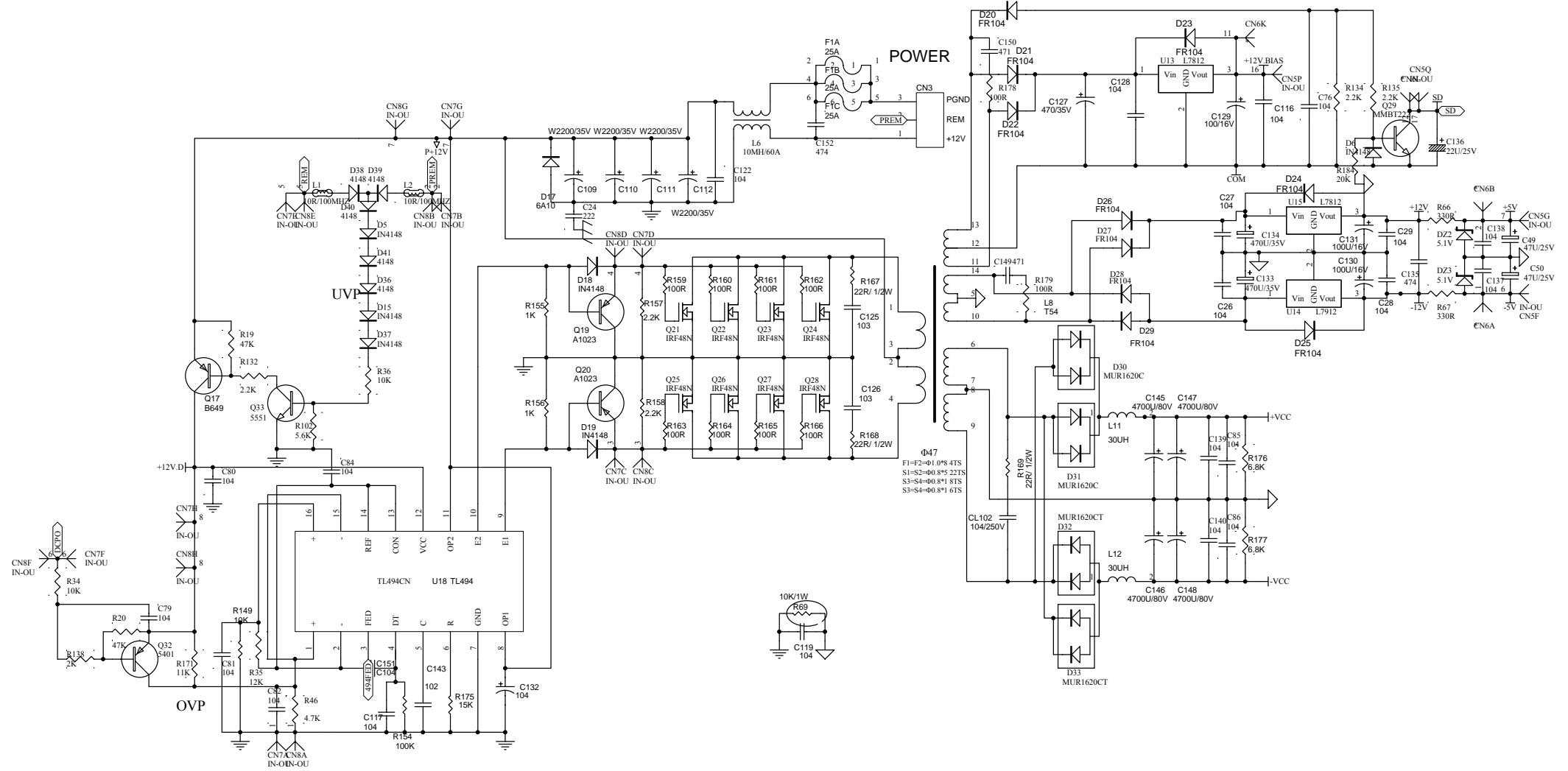

ECN NO	DESCRIPTION	APPROVED	DATA	DWG NO:
				PART NO:
				PART NAME:
				SCALE: 1:1
				DRAWN BY:
				CHECKED BY:
				UNIT: MM
				SIZE: A4
				APPROVED BY:
				DATA:
				REV: 2.0
				SHEET: 24

1600a Reference Series

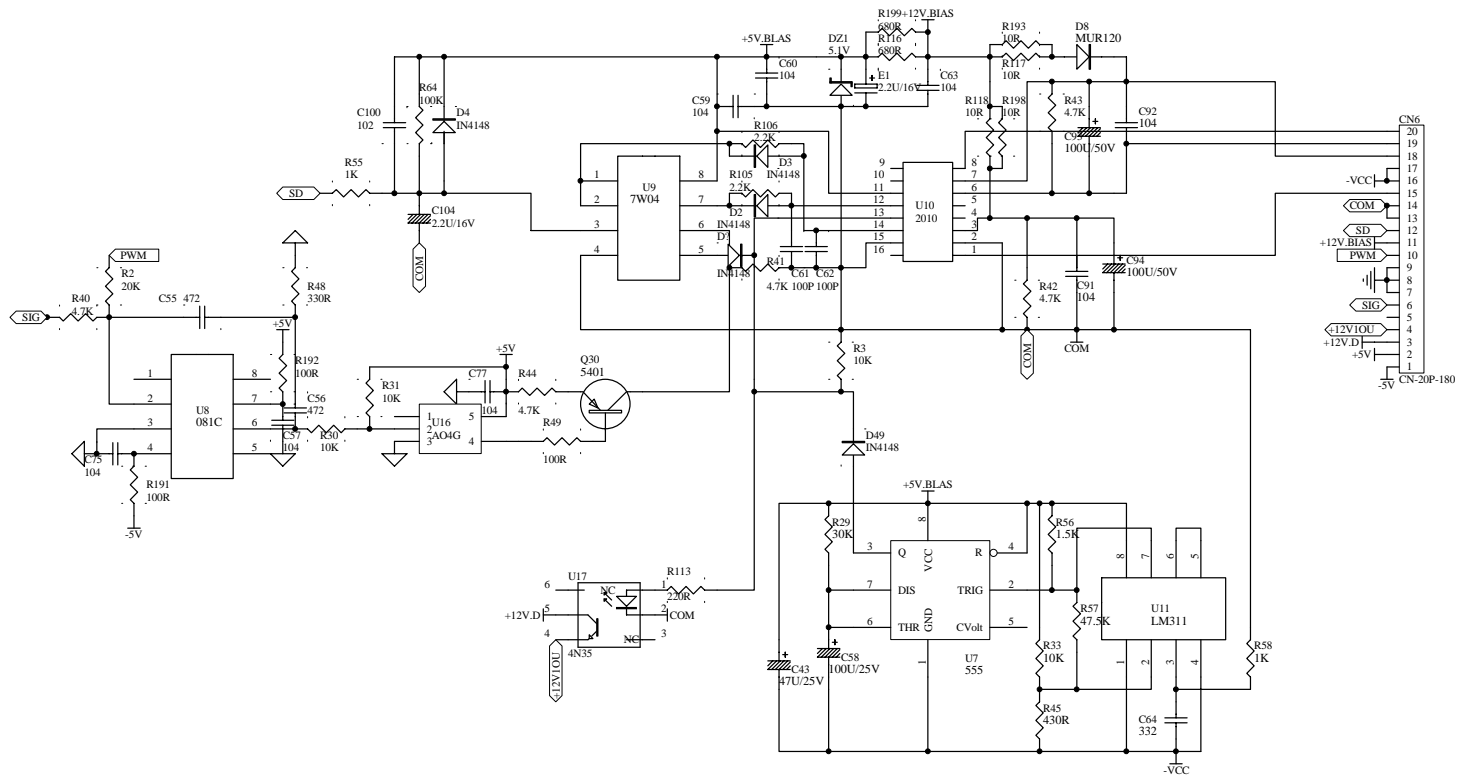

ECN NO	DESCRIPTION	APPROVED	DATA	EVR			DW GNO:
				PART NAME:	SCALE: 1:1	DRAWN BY:	PART NO:
				AMP	UNITS: MM	CHECKED BY:	DATA:
				PRODUCT MODE:	SIZE: A4	APPROVED BY:	DATA:
				infinity REF-1600	REV: 2.0		

