

# **INSTRUCTION MANUAL**

**MICRO TECH™ 1000**  
**PROFESSIONAL POWER AMPLIFIER**

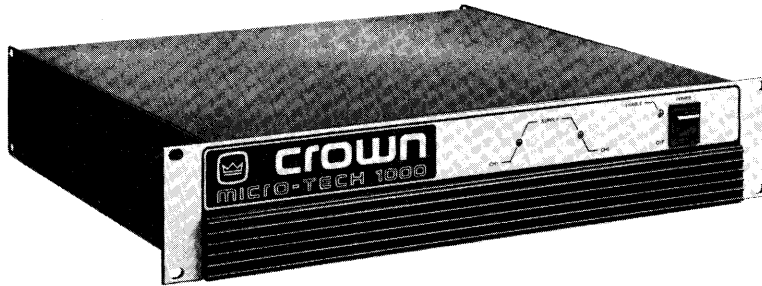
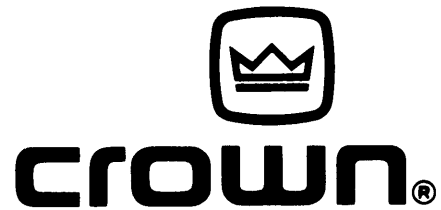

# INSTRUCTION MANUAL

## MICRO TECH™ 1000 PROFESSIONAL POWER AMPLIFIER

Micro-Tech™ is a trademark of Crown International, Inc., 1718 W. Mishawaka Road, Elkhart, Indiana 46517.

The information furnished in this manual does not include all of the details of design, production, or variations of the equipment. It does not cover all the possible contingencies which may arise during operation, installation, or maintenance. Should special problems arise, or further information be desired, please contact the Crown International Customer Services Department.

Crown International  
1718 W. Mishawaka Rd.  
Elkhart, Indiana 46517  
Ph: (219) 294-8000

## WARNING

**TO PREVENT SHOCK OR FIRE HAZARD DO NOT EXPOSE TO RAIN  
OR MOISTURE!**

## CAUTION

**TO PREVENT ELECTRIC SHOCK DO NOT USE THIS (POLARIZED)  
PLUG WITH AN EXTENSION CORD, RECEPTACLE OR OTHER  
OUTLET UNLESS THE BLADES CAN BE FULLY INSERTED TO  
PREVENT BLADE EXPOSURE.**

## ATTENTION

**POUR PREVENIR LES CHOCS ELECTRIQUES NE PAS UTILISER  
CETTE FICHE POLARISEE AVEC UN PROLONGATEUR. UNE PRISE  
DE COURANT OU UNE AUTRIE SORTIE DE COURANT, SAUF SI LES  
LAMES PEUVENT ETRE INSEREES A FOND SANS EN LAISSER  
AUCUNE PARTIE A DECOUVERT.**

### FULL THREE-YEAR WARRANTY

#### SUMMARY OF WARRANTY

We, CROWN INTERNATIONAL, INC., 1718 West Mishawaka Road, Elkhart, Indiana 46517 (Warrantor) warrant to you, the ORIGINAL PURCHASER AND ANY SUBSEQUENT OWNER of each NEW Crown product, for a period of three (3) years from the date of purchase by the original purchaser (warranty period) that the product is free of defects in materials or workmanship and will meet or exceed all advertised specifications for such a product.

#### ITEMS EXCLUDED FROM WARRANTY

We are not responsible for product failure caused by misuse, accident or neglect. This warranty does not extend to any product on which the serial number has been defaced, altered, or removed. It does not cover damage to speakers or any other products resulting from Crown product failure. It does not cover defects or damage caused by your use of unauthorized modifications, parts, or service. It also excludes batteries, and damage caused by leaky or defective batteries.

#### WHAT WE WILL DO

We will remedy any defect in materials or workmanship by repair, replacement, or refund. We may not elect refund unless you agree, or unless we are unable to provide replacement, and repair is not practical or cannot be timely made. If a refund is elected, then you must make the defective or malfunctioning component available to Crown free and clear of all liens or other encumbrances. The refund will be equal to the actual purchase price, not including interest, insurance, closing costs, and other finance charges less a reasonable depreciation on the product from the date of original purchase. Warranty work can only be performed at our authorized service centers or at the Crown factory. We will remedy the defect and ship the product from the service center or Crown factory within a reasonable time after receipt of the defective product at the authorized service center or the Crown factory. All expenses in remedying the defect, including shipping costs in the United States, will be borne by Crown. (Purchaser must bear the expense of shipping the product between any foreign country and the port of entry in the United States and all taxes, duties, and other custom's fee for such foreign shipments).

#### HOW TO OBTAIN WARRANTY SERVICE

You must notify us of your need for warranty service not later than ninety (90) days after expiration of the warranty period. We will give you written notice of the dealer service centers to whom you may deliver the product, or we will give you an authorization to return it for factory service. All components must be shipped in a factory pack, which, if needed, may be obtained from Crown free of charge. Corrective action will be taken within a reasonable time of the date of receipt of the defective product by us or our service center. If the repairs made by Crown or the authorized service center are not satisfactory, notify Crown or the authorized service center immediately.

#### DISCLAIMER OF CONSEQUENTIAL AND INCIDENTAL DAMAGES

YOU ARE NOT ENTITLED TO RECOVER FROM US ANY CONSEQUENTIAL OR INCIDENTAL DAMAGES RESULTING FROM ANY DEFECT IN OUR PRODUCT. THIS INCLUDES ANY DAMAGE TO ANOTHER PRODUCT OR PRODUCTS RESULTING FROM SUCH A DEFECT. SOME STATES DO NOT ALLOW THE EXCLUSION OR LIMITATIONS OF INCIDENTAL OR CONSEQUENTIAL DAMAGES, SO THE ABOVE LIMITATION OR EXCLUSION MAY NOT APPLY TO YOU.

#### WARRANTY ALTERATIONS

NO PERSON HAS THE AUTHORITY TO ENLARGE, AMEND, OR MODIFY THIS WARRANTY. THE WARRANTY IS NOT EXTENDED BY THE LENGTH OF TIME WHICH YOU ARE DEPRIVED OF THE USE OF THE PRODUCT. REPAIRS AND REPLACEMENT PARTS PROVIDED UNDER THE TERMS OF THIS WARRANTY SHALL CARRY ONLY THE UNEXPIRED PORTION OF THIS WARRANTY.

#### DESIGN CHANGES

We reserve the right to change the design of any product from time to time without notice and with no obligation to make corresponding changes in products previously manufactured.

#### LEGAL REMEDIES OF PURCHASER

THIS WARRANTY GIVES YOU SPECIFIC LEGAL RIGHTS, AND YOU MAY ALSO HAVE OTHER RIGHTS WHICH VARY FROM STATE TO STATE. No action to enforce this Warranty shall be commenced later than ninety (90) days after expiration of the warranty period.

CROWN INTERNATIONAL, INC.  
1718 West Mishawaka Road, Elkhart, Indiana 46517

THIS STATEMENT OF WARRANTY SUPERSEDES ALL OTHERS CONTAINED IN THIS MANUAL.

11/81



## TABLE OF CONTENTS

<b>Section 1</b>	<b>General Information</b>	
1.1	Introduction .....	1-1
<b>Section 2</b>	<b>Specifications and Performance</b>	
2.1	General Specifications .....	2-1
2.2	Stereo Specifications .....	2-1
2.3	Parallel Monophonic Specifications .....	2-2
2.4	Bridge Mono Specifications .....	2-2
2.5	Performance Graphs .....	2-3
<b>Section 3</b>	<b>Installation and Operation</b>	
3.1	Unpacking .....	3-1
3.2	Mounting .....	3-1
3.3	Operating Precautions .....	3-1
3.4	Connecting Output Lines .....	3-1
3.5	Monophonic Operation .....	3-3
3.6	Connecting Input Lines .....	3-5
3.7	Connecting Power .....	3-5
3.8	Control Adjustments .....	3-5
3.9	The Protection Mechanisms .....	3-5
3.10	Load Protection Methods .....	3-6
3.11	Cleaning .....	3-6
<b>Section 4</b>	<b>Theory of Operation</b>	
4.1	General Information .....	4-1
4.2	Block Diagram Circuit Theory .....	4-1
<b>Section 5</b>	<b>Accessories/Options</b>	
5.1	Input Sensitivity Option .....	5-1
5.2	Cooling Fan Option .....	5-1



## LIST OF ILLUSTRATIONS

Fig. 1.1	Micro-Tech 1000 Front Panel.....	1-1
Fig. 2.1	Typical Frequency Response .....	2-3
Fig. 2.2	Typical Phase Response .....	2-3
Fig. 2.3	Typical Power Output, Stereo Mode; 8, 4 and 2 Ohms .....	2-4
Fig. 2.4	Typical Power Output, Bridged Mono Mode; 16, 8, and 4 Ohms.....	2-4
Fig. 2.5	Typical I.M. Distortion, Parallel Mono Mode; 8, 4 and 2 Ohms .....	2-5
Fig. 2.6	Typical I.M. Distortion; Stereo Mode; 8, 4 and 2 Ohms .....	2-5
Fig. 2.7	Typical Damping Factor .....	2-6
Fig. 2.8	Typical Crosstalk .....	2-6
Fig. 2.9	Typical Output Impedance .....	2-7
Fig. 2.10	Typical Phase Angle .....	2-7
Fig. 3.1	Micro-Tech 1000 Mounting Dimensions.....	3-1
Fig. 3.2	Micro-Tech 1000 Rear Panel .....	3-2
Fig. 3.3	Banana (MDP) Plug.....	3-2
Fig. 3.4	Typical System Hookup .....	3-2
Fig. 3.5	Wire-Size Nomograph .....	3-3
Fig. 3.6	Jumper-Wire Location for Bridge-Mono Operation.....	3-4
Fig. 3.7	Parallel Mono Hookup .....	3-4
Fig. 3.8	Effect of Input-Capacitor Value on Frequency Response .....	3-5
Fig. 3.9	RFI Filters.....	3-5
Fig. 3.10	Fuse Selector Nomograph for Loudspeaker Protection .....	3-6
Fig. 3.11	Relay-Controlled Protector with Overload Indicator.....	3-6
Fig. 3.12	Dust Filter .....	3-7
Fig. 4.1	Block Diagram .....	4-2



## SECTION 1 GENERAL INFORMATION

### 1.1 Introduction

The Crown Micro-Tech™ 1000 is a miniaturized yet high-technology stereo power amplifier for professional sound reinforcement and recording. This amplifier provides enormous power within a low-profile package. It took Crown technology to improve performance while reducing size and cost.

The Micro-Tech can deliver 1000 watts RMS in mono mode at less than 1 percent THD, into 1 or 4 ohms. A "parallel mono" switch combines the outputs of both channels to make a monophonic amplifier capable of 1000 watts into 1 ohm. By adding an internal jumper for the "bridge mono" configuration, the user can obtain 1000 watts into 4 ohms.

In stereo mode, at 1 kHz, the Micro-Tech provides 500 watts continuous average power per channel into 2 ohms, 400 watts into 4 ohms, and 280 watts into 8 ohms with no more than 0.25% THD. From 20 Hz to 20 kHz, the unit delivers 250 watts per channel into 8 ohms at 0.1% THD.

The grounded-bridge circuitry has many advantages over conventional designs to offer a high value to our customers.

Patented Crown circuitry allows extreme voltage swings without putting output transistors in series; this

provides lower distortion and greater reliability. Reliability is further enhanced by a redundant power supply. The Micro-Tech uses an "Output Device Emulator Protection" (ODEP) circuit which simulates the output transistors. With this circuit, the amplifier can detect and compensate for overheating and overload. The unit is also protected against output shorts, open circuits, mismatched loads, overall overheating, and high-frequency overloads.

Efficient heat sinking and a self-contained forced-air cooling system prevent overheating and prolong component life. The direction of airflow may be reversed, if necessary, to work with the rack cooling system -- a feature unique to Crown. The dust filter located on the front of the unit is easily removed for cleaning or replacement.

Inputs are balanced 1/4" phone jacks with adjustable gain. Outputs are 5-way banana jacks for minimum power loss.

Chassis ground and signal ground are isolated to reduce hum from ground loops.

The design of the package permits stacking of several amplifiers atop each other. The Micro-Tech also is rack-mountable in a standard 19" rack, using the four mounting screws and four nylon washers included.

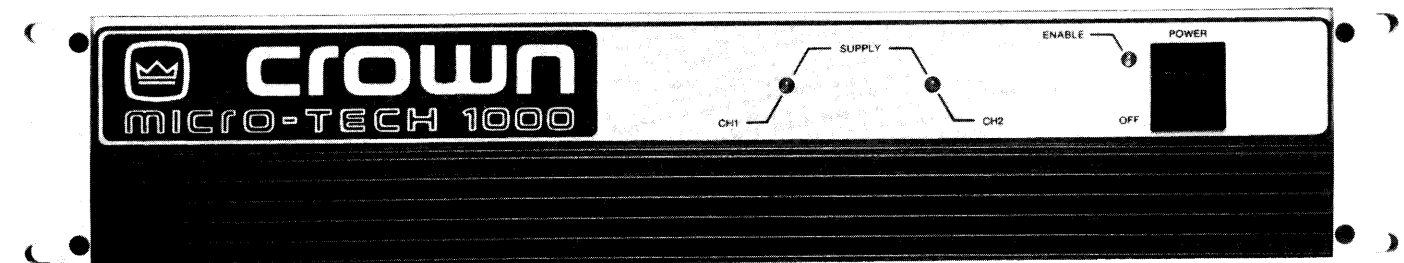

Fig. 1.1 Micro-Tech 1000 Front Panel



## SECTION 2 SPECIFICATIONS AND PERFORMANCE

### 2.1 General Specifications

**General Protection:** Protection circuitry limits the output level to protect the output transistor stage, even in the case of elevated temperature. Transformer overheating results in shutdown of that particular channel. Controlled slewing-rate voltage amplifiers protect the unit against RF burnouts. Input overload protection is furnished by a resistor at the amplifier input to limit current.

**DC Output Offset:** (Shorted input) +/-10 millivolts.

**Hum and Noise:** 2.2-volt sensitivity: 110 dB below rated output (A-weighted); 105 dB below rated output (20Hz-20kHz); 0.775-volt sensitivity: 105 dB below rated output (A-weighted).

**Phase Response:** + /-10 degrees 10Hz-20kHz at 1 watt.

**Input Impedance:** Nominally 20K ohms, balanced. Nominally 10K ohms, unbalanced.

**High Voltage Power Supply:** Two 900 VA transformers with computer-grade capacitors.

**Low Voltage Power Supply:** +/-15V DC supplies are provided by a fanformer (an added winding on the fan motor), regulated by three terminal regulators.

**Power Requirements:** 60Hz, 120V AC. Draws 60 watts or less on idle, 1100 W at 250 W/channel output into 8 ohms.

**Turn On:** No dangerous transients.

**Front Panel Control:** Two-position ON/OFF rocker switch.

**Rear Panel Controls:** Channel 1 and Channel 2 input level controls. Parallel-mono pushbutton switch.

**Display:** Amber LED pilot light driven by low-voltage power supply. Two amber LEDs to indicate the status of the high-voltage supplies: thermal shutdown or blown line fuse.

**Connectors:** Inputs - balanced 1/4" phone jacks. Outputs - color-coded dual binding posts on standard 3/4" centers; spaced 3/4" apart for bridge mono (balanced) output connection.

AC Line - Two-wire, 20 A, 120 V male connector with 5 ft. cable.

**Dimensions:** 19" standard rack mount (EIA Std. RS-310-B), 3 1/2" height, 16" behind mounting surface. Center of gravity is 6" behind the front panel.

**Weight:** 38 pounds (17.24Kg) net weight.

**Finish:** Black splatter-coat steel chassis.

**Construction:** Steel chassis, specially designed "flow-through" ventilation from front to side panels.

**Heat Sinking:** Forced-air cooling through internal heat spreaders.

### 2.2 Stereo Specifications

**Output Power (2 ohms):** 500 watts continuous average power per channel at 1kHz into 2 ohms with no more than 0.25% THD

**Output Power (4 ohms):** 400 watts continuous average power per channel at 1kHz into 4 ohms with no more than 0.25% THD. 350 watts +/-1 dB per channel, 20Hz - 20kHz into 4 ohms with no more than 1% THD (EIA Std. SE-101-A).

**Output Power:** 280 watts continuous average power per channel at 1kHz into 8 ohms with no more than 0.25% THD. 250 watts +/-1 dB per channel continuous average power (both channels operating into an 8 ohm load, 20Hz - 20kHz at a rated RMS sum total harmonic distortion of 0.1% of the fundamental output voltage (tested per FTC specifications). 265 watts +/-1 dB per channel, 20Hz - 20kHz into 8 ohms with no more than 1.0% THD (EIA Std. SE-101-A).

**Frequency Response:** +/-0.1 dB 20Hz - 20kHz at 1 watt into 8 ohms.

**Harmonic Distortion:** Less than 0.05% from 20Hz - 1kHz and increasing linearly to 0.1% at 20kHz delivering 250 watts into 8 ohms, per channel.

**IM Distortion:** Less than 0.05% from 25 milliwatts to 250 watts into 8 ohms, per channel.

**Slew Rate:** Greater than 13 volts per microsecond.

**Damping Factor:** Greater than 1000, 10Hz to 400Hz into 8 ohms.

**Load Impedance:** Rated for 8, 4, and 2 ohm usage, safe with all loads.

**Output Impedance:** Less than 63 milliohms in series with less than 0.75 microhenries.

**Voltage Gain:** 20 +/-2% or 26 dB +/- 0.5 dB at maximum gain.

**Input Sensitivity:** 2.2 volts unbalanced for 250 watts into 8 ohms; 0.775 volt unbalanced for rated output (see Section 5.1).

**Output Signal:** Unbalanced, dual channel.

### 2.3 Parallel Monophonic Specifications

**Output Power (1 ohm):** 1000 watts continuous average power at 1kHz with no more than 0.25% THD.

**Output Power (2 ohms):** 800 watts continuous average power at 1kHz with no more than 0.25% THD.

**Output Power (4 ohms):** 500 watts continuous average power +/-1 dB, 20Hz - 20kHz, with no more than 1.0% THD (EIA Std. SE-101-A).

**Output Power (8 ohms):** 300 watts continuous average power +/-1 dB, 20Hz - 20kHz, with no more than 1.0% THD (EIA Std. SE-101-A).

**Frequency Response:** +/-0.1 dB, 20Hz - 20kHz at 1 watt into 16 ohms.

**Harmonic Distortion:** Less than 0.01% from 20Hz to 1kHz and increasing linearly to 0.20% at 20kHz, 200 watts into 16 ohms. Less than 0.01% from 20Hz to 1kHz and increasing linearly to 0.20% at 20kHz, 300 watts into 8 ohms.

**IM Distortion:** Less than 0.03% from 0.6 watt to 600 watts into 4 ohms. Less than 0.1% from 60 milliwatts to 0.6 watt into 4 ohms.

**Slew Rate:** Greater than 13 volts per microsecond.

**Damping Factor:** Greater than 1000, 10Hz - 400Hz into 4 ohms.

**Output Impedance:** Less than 31 milliohms in series with less than .75 microhenries.

**Load Impedance:** Rated for 8, 4, 2 and 1 ohm usage, safe with all loads.

**Voltage Gain:** 20 +/-2 % or 26 dB +/-0.5 dB at maximum gain.

**Input Sensitivity:** 2.2 volts unbalanced for 500 watts into 4 ohms; 0.775 volt unbalanced for rated output (see Section 5.1).

**Output Signal:** Unbalanced, single channel. Channel 1 controls are active; Channel 2 inactive.

### 2.4 Bridge Mono Specifications

**Output Power (4 ohms):** 1000 watts continuous average power at 1kHz with no more than 0.25% THD.

**Output Power (8 ohms):** 800 watts continuous average power +/-1 dB, 20Hz - 20kHz, with no more than 1.0% THD (EIA Std. SE-101-A).

**Output Power (16 ohms):** 540 watts continuous average power +/-1 dB, 20Hz - 20kHz, with no more than 1.0% THD (EIA Std. SE-101-A).

**Frequency Response:** +/-0.1 dB, 20Hz - 20kHz at 1 watt into 16 ohms.

**Harmonic Distortion:** Less than 0.05% from 20Hz to 1kHz and increasing linearly to 0.15% at 20kHz, 500 watts into 16 ohms. Less than 0.05% from 20Hz to 1kHz and increasing linearly to 0.1% at 20kHz, 725 watts into 8 ohms.

**IM Distortion:** Less than 0.02% from 0.6 watt to 600 watts into 16 ohms. Less than 0.05% from 0.06 watt to 0.6 watt into 8 ohms.

**Slew Rate:** Greater than 26 volts per microsecond.

**Damping Factor:** Greater than 1000, 10-400Hz into 16 ohms.

**Output Impedance:** Less than 150 milliohms in series with less than 1.5 microhenries.

**Load Impedance:** Rated for 4, 8, and 16 ohm usage, safe with all loads.

**Voltage Gain:** 40 +/-2% or 32 dB +/- 0.6 dB at maximum gain.

**Input Sensitivity:** 2.2 volts unbalanced for 500 watts into 16 ohms; 0.775 volt unbalanced for rated output (see Section 5.1).

**Output Signal:** Balanced, single channel. Channel 1 controls are active; Channel 2 inactive but not removed from operation.

## 2.5 Performance Graphs

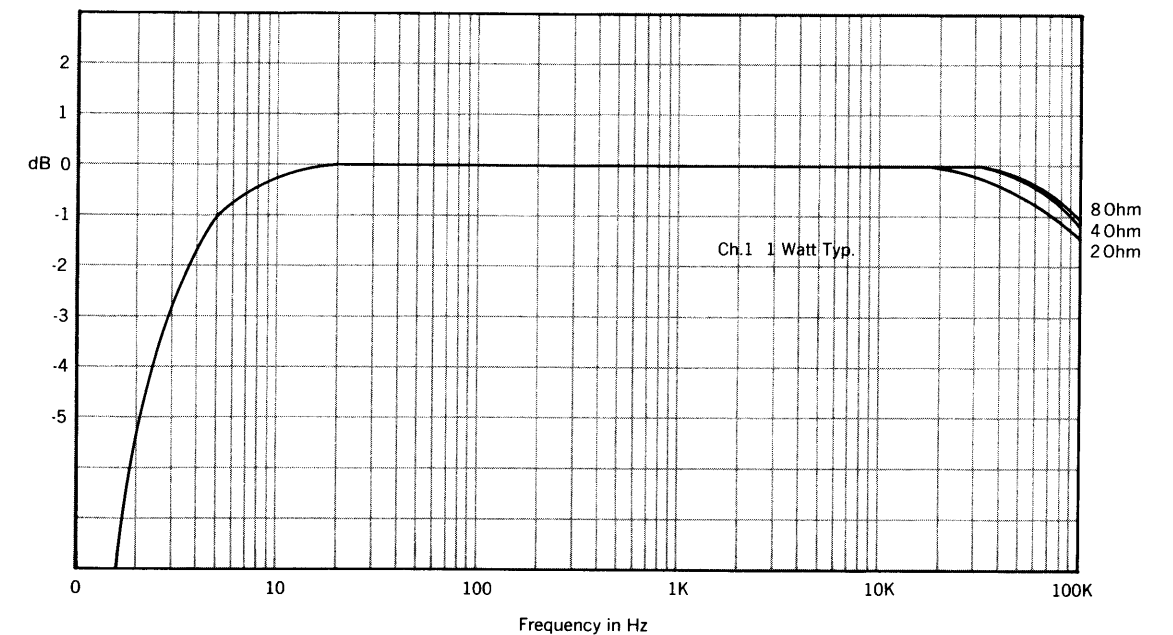

Fig. 2.1 Typical Frequency Response

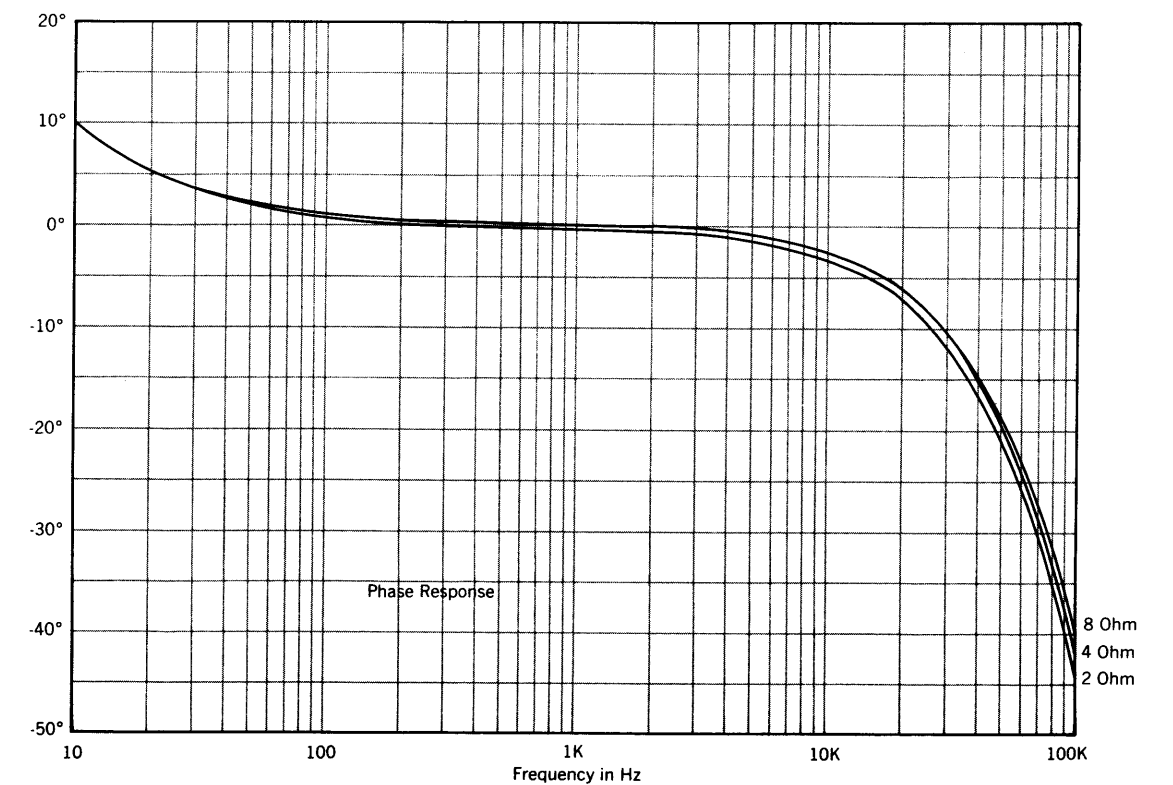

Fig. 2.2 Typical Phase Response

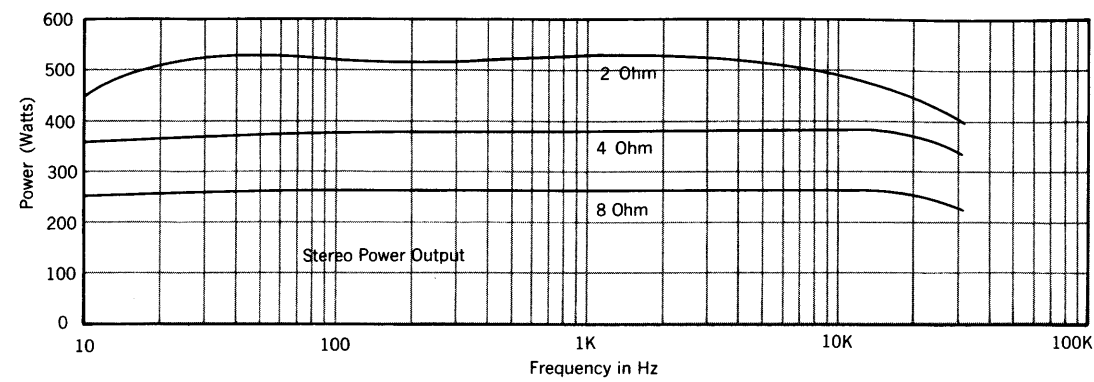

Fig. 2.3 Typical Power Output, Stereo Mode;  
8, 4 and 2 Ohms

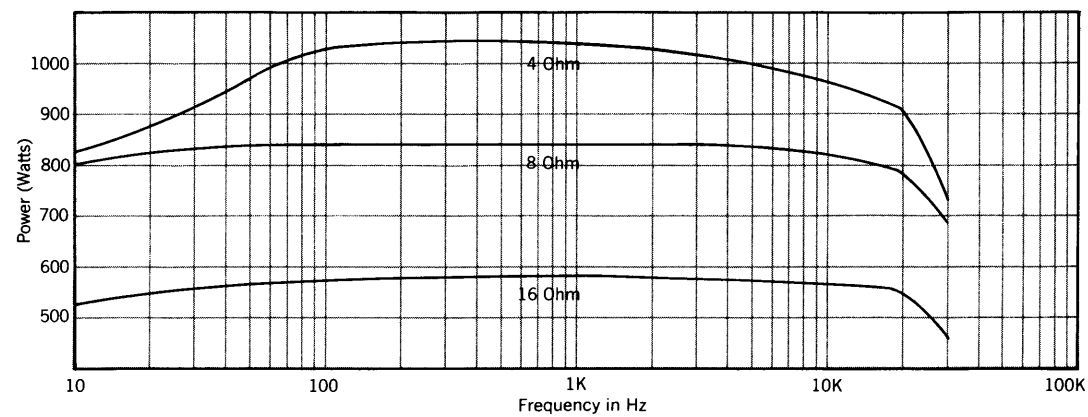

Fig. 2.4 Typical Power Output, Bridged Mono Mode;  
16, 8 and 4 Ohms

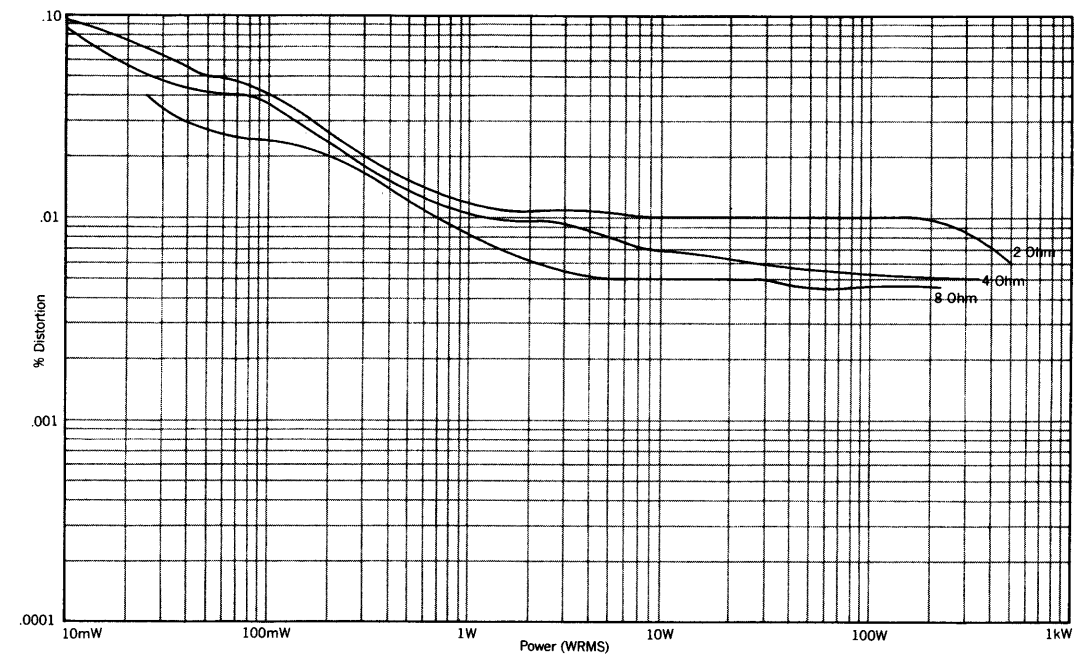

Fig. 2.5 Typical I.M. Distortion, Parallel Mono Mode;  
8, 4 and 2 Ohms

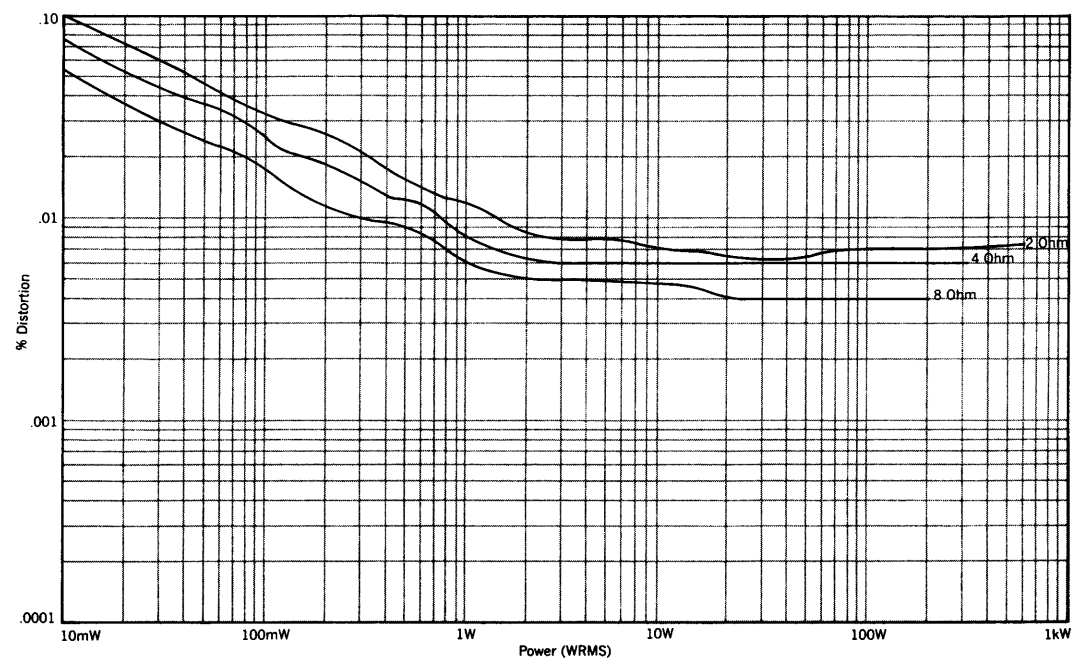

Fig. 2.6 Typical I.M. Distortion; Stereo Mode,  
8, 4 and 2 Ohms



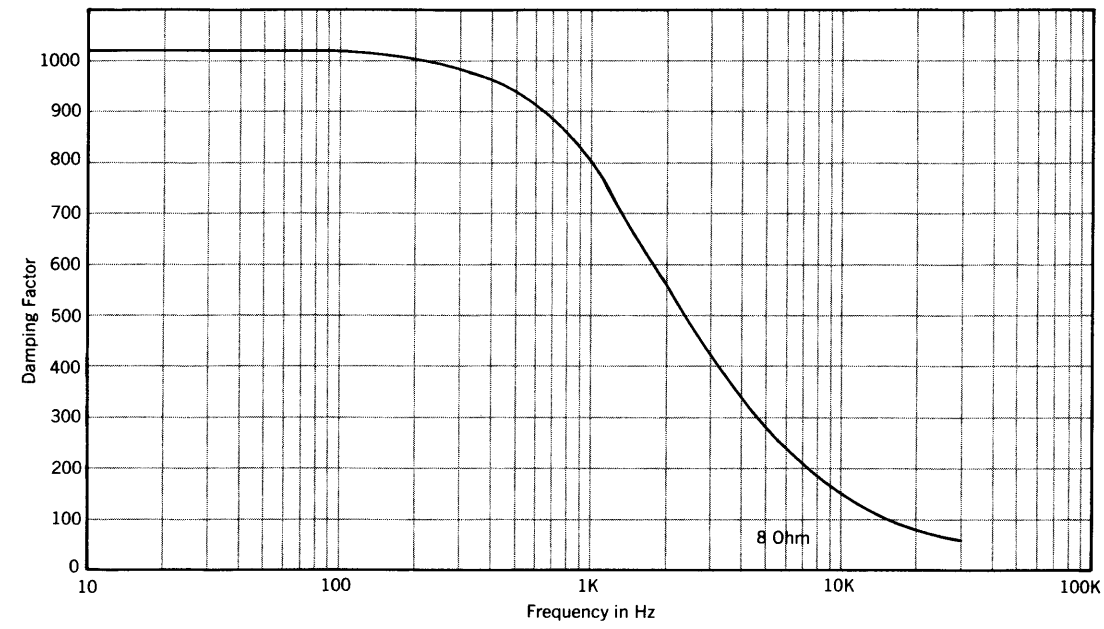

Fig. 2.7 Typical Damping Factor

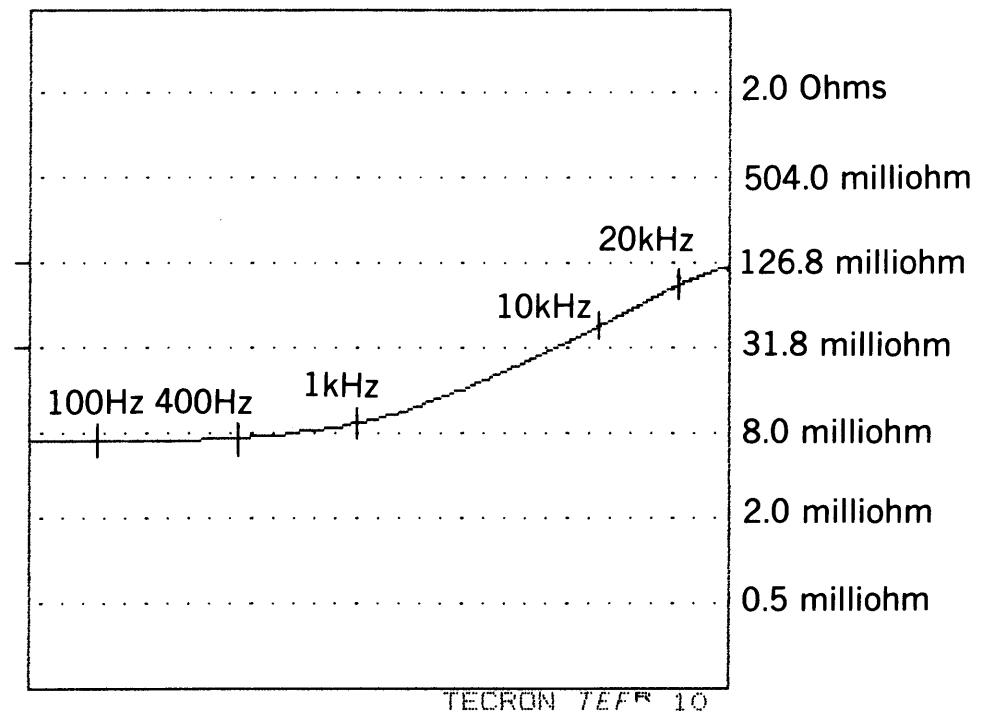

Fig. 2.9 Typical Output Impedance

Figs. 2.8, 2.9, and 2.10 were measured on a Tecron TEF® System 10 Audio Analyzer/Computer.

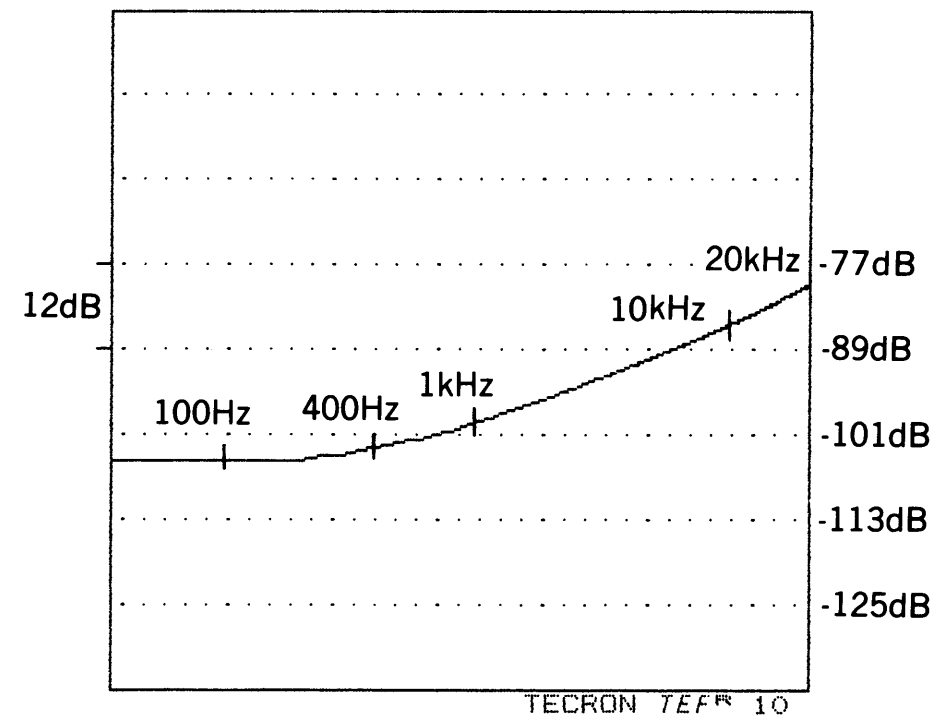

Fig. 2.8 Typical Crosstalk

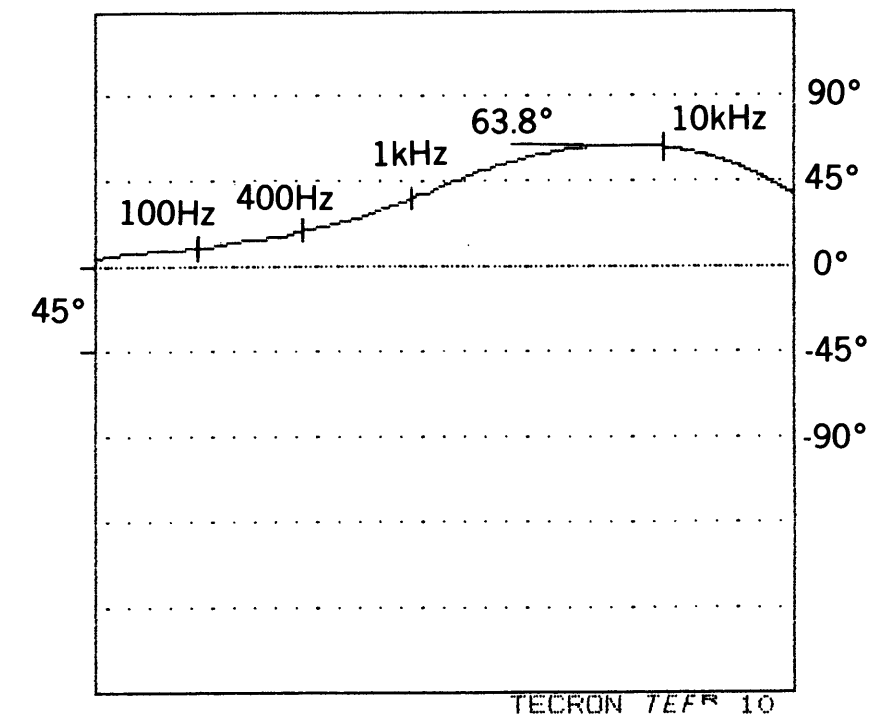

Fig. 2.10 Typical Phase Angle



## SECTION 3 INSTALLATION AND OPERATION

### 3.1 Unpacking

As soon as you receive the unit, please inspect for any damage incurred in transit. Since the unit was carefully inspected and tested at the factory, it left unmarred. If damage is found, notify the transportation company immediately. Only the consignee may institute a claim with the carrier for damage during shipment. However, Crown will cooperate fully in such an event. Be sure to save the carton as evidence of damage for the carrier's inspection.

Even if the unit arrived in perfect condition, as most do, it is advantageous to save the packing materials. They will help prevent damage if you ever need to transport or ship the unit. Note the carton and internal pack. Each is designed for protection during transit. **Do not ship the unit without this factory pack!**

### 3.2 Mounting

The Micro-Tech is designed for standard 19" rack mounting as well as "stack" mounting without a cabinet. The feet can be removed if necessary. Mounting dimensions are shown in Fig. 3.1.

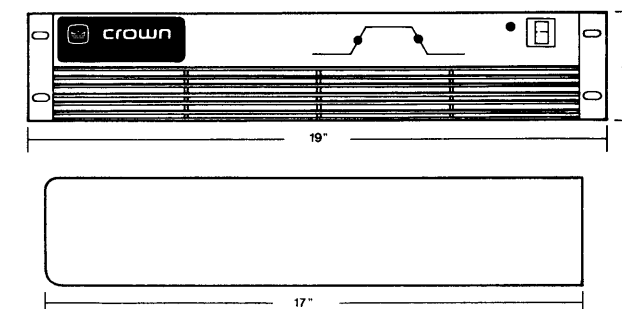

Fig. 3.1 Micro-Tech 1000 Mounting Dimensions

For mobile installations, screw the rear panel onto the rear of the rack cabinet.

If the air supply is unusually dusty, you may want to pre-filter the air supply using commercial furnace filters, etc., to prevent rapid loading of the unit's own air filter. If the unit's filter becomes plugged, it can be

cleaned with mild dish detergent and water; replacement is not necessary.

### 3.3 Operating Precautions

Although your Micro-Tech amplifier is well protected from any external faults, we recommend these precautions for safe operation:

1. There are two modes of mono operation (parallel mono and bridge mono). Read Section 3.5 to determine which mode you need.
2. After wiring the unit for PARALLEL MONO, do not operate the amplifier in stereo mode. Check the position of the parallel-mono switch on the back panel.
3. Use care in making connections, selecting signal sources, and controlling the output level. The load you save may be your own.
4. Do not short the ground lead of an output cable to the input signal ground. This may form a ground loop and cause oscillations.
5. Operate the amplifier from AC mains of not more than 10% above the selected line voltage, and only the line frequency specified. Failure to comply with these voltage and frequency limits will invalidate the warranty.
6. Never connect the output to a power-supply output, battery, or power main. Damage incurred by such a hookup is not covered by the warranty.
7. Tampering in the circuit by unqualified personnel, or making unauthorized circuit changes invalidates the warranty.

### 3.4 Connecting Output Lines

It is always wise to remove power from the unit and turn the input level controls off (CCW) while making connections, especially if the load is a loudspeaker system. This will eliminate any chance of loud blasts or damage to the loudspeaker.

The Micro-Tech output connectors are on the rear of the amplifier, as shown in Fig. 3.2. A preferred speaker-cable connector is a "dual banana" (MDP)

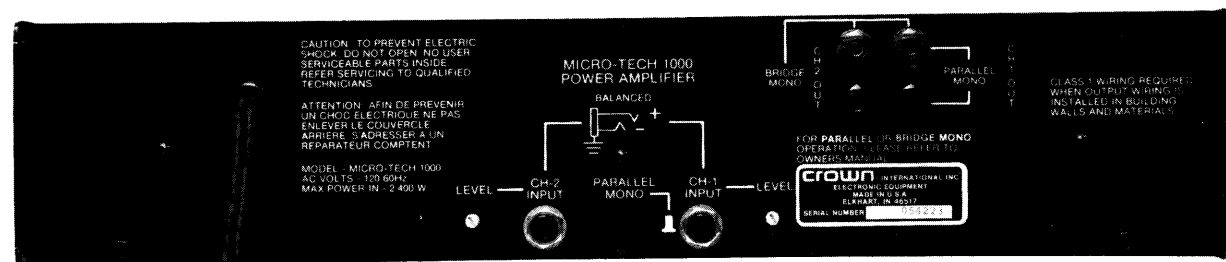

Fig. 3.2 Micro-Tech 1000 Rear Panel

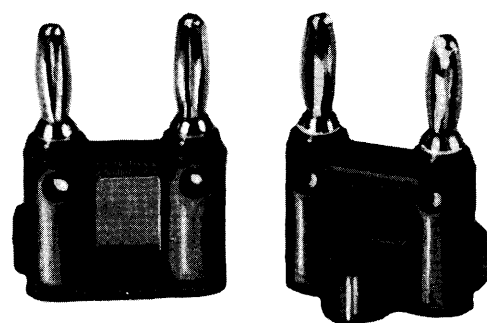

Fig. 3.3 Banana (MDP) Plug

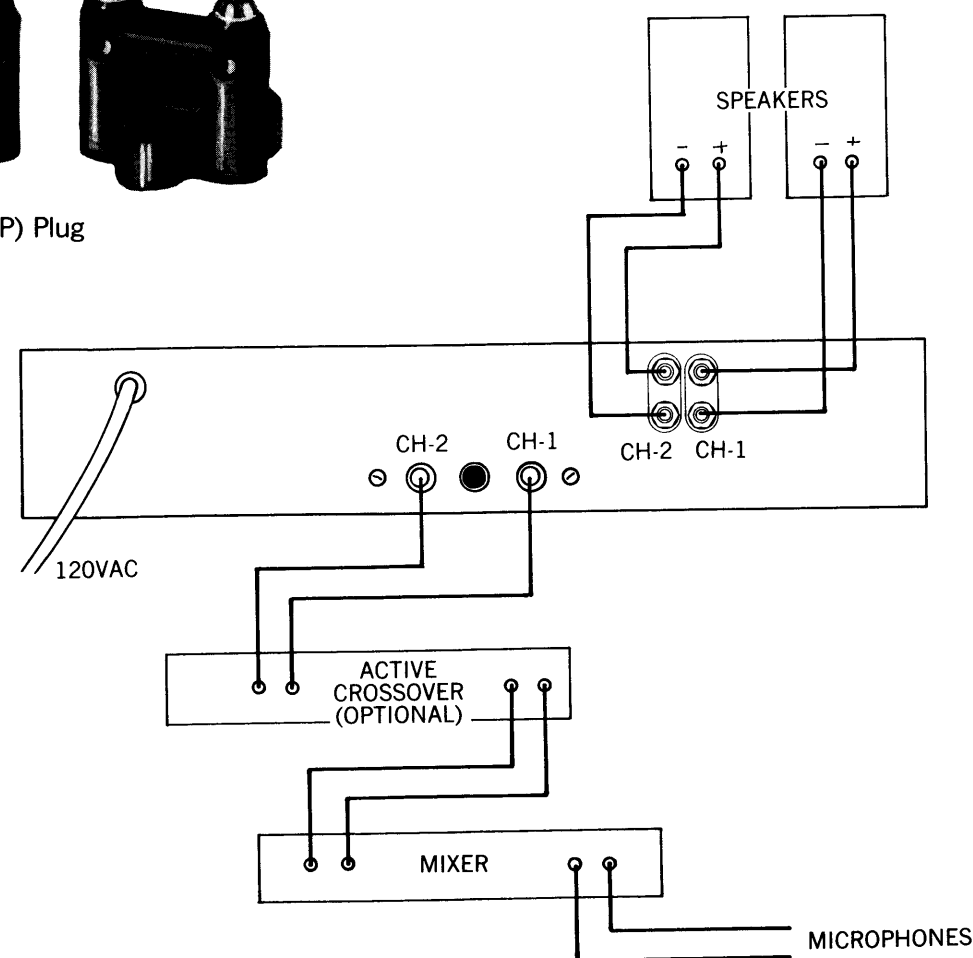

Fig. 3.4 Typical System Hookup

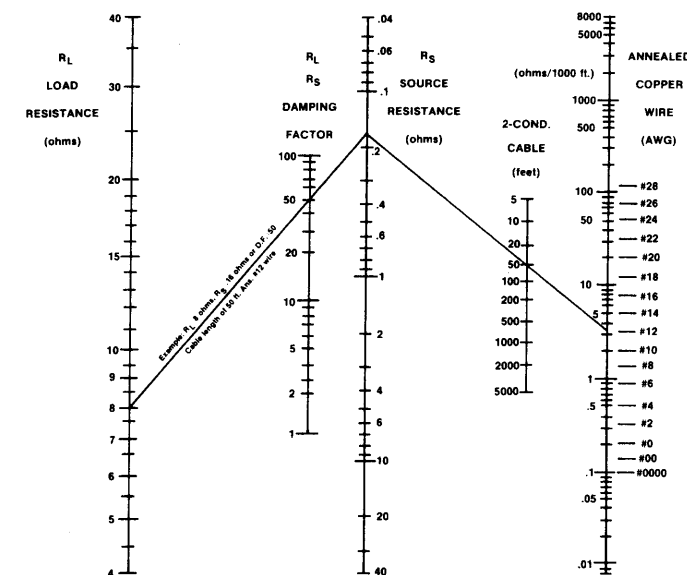

Fig. 3.5 Wire-Size Nomograph

plug (Fig. 3.3). Check for a snug fit because plugging and unplugging loosens these connections.

Figure 3.4 shows a typical system hookup.

Use speaker cables of sufficient gauge (thickness) for the length used. Otherwise power is lost through cable heating, and damping factor is decreased due to cable resistance. Refer to the nomograph (Fig. 3.5) for recommended wire sizes.

To prevent high-frequency oscillations:

1. Lace speaker cables together.
2. Keep speaker cables well separated from input cables.
3. Never connect the amplifier's input and output grounds together.
4. As a last resort, lowpass filter the input signal.

### 3.5 Monophonic Operation

Parallel mono mode is recommended for loads less than 4 ohms. Bridge mono mode is recommended for loads 4 ohms or greater.

#### Bridge Mono Operation - Method A

1. Remove the bottom cover.
2. Add a jumper wire as shown in Fig. 3.6.
3. Replace the cover.
4. Push in the "Parallel Mono" pushbutton switch on the rear of the amplifier.
5. Plug the input line into the Channel 1 input jack, and adjust the level with the Channel 1 input-level control only.
6. Do not use the Channel 2 input; otherwise distortion may result. Unplug the input to Channel 2 when operating in mono, and turn the Channel 2 level control fully CCW.

#### Bridge Mono Operation - Method B

This method is desirable for installations in which the amplifier is converted frequently between stereo and mono operation. With this method, the amplifier can be replaced without re-setting the parallel-mono switch, because switching is automatic.

For an unbalanced input signal, make a Y-adaptor using stereo phone plugs as follows:

1. Connect the signal cable HOT lead to Ch. 1 tip and Ch. 2 ring.
2. Connect the signal cable SHIELD to Ch. 1 sleeve (ground) and ring, and to Ch. 2 sleeve and tip.
3. Connect the speakers as shown in Fig. 3.6.

For a balanced input signal, make a Y-adaptor using stereo phone plugs as follows:

1. Connect the signal-cable POSITIVE lead to Ch. 1 tip and Ch. 2 ring.
2. Connect the signal-cable NEGATIVE lead to Ch. 1 ring and Ch. 2 tip.
3. Connect the signal-cable SHIELD to Ch. 1 and Ch. 2 sleeves (grounds).
4. Connect the loudspeakers as shown in Fig. 3.6.

**Caution: Be certain that all equipment (meters, switches, etc.) connected to the mono output lines is balanced. To prevent oscillations, both sides of the line must be totally isolated from the input grounds.**

The output from the Micro-Tech in BRIDGE MONO is BALANCED and is isolated from the chassis, and from the input grounds. Because of the panel-mounting configuration of the dual-banana output jack, it is possible to use only one banana plug. Connect both load leads to the red or "hot" connectors only.

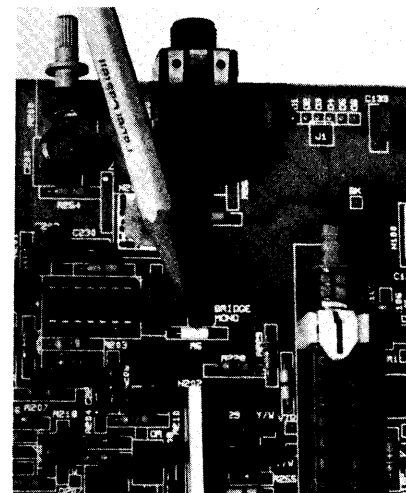
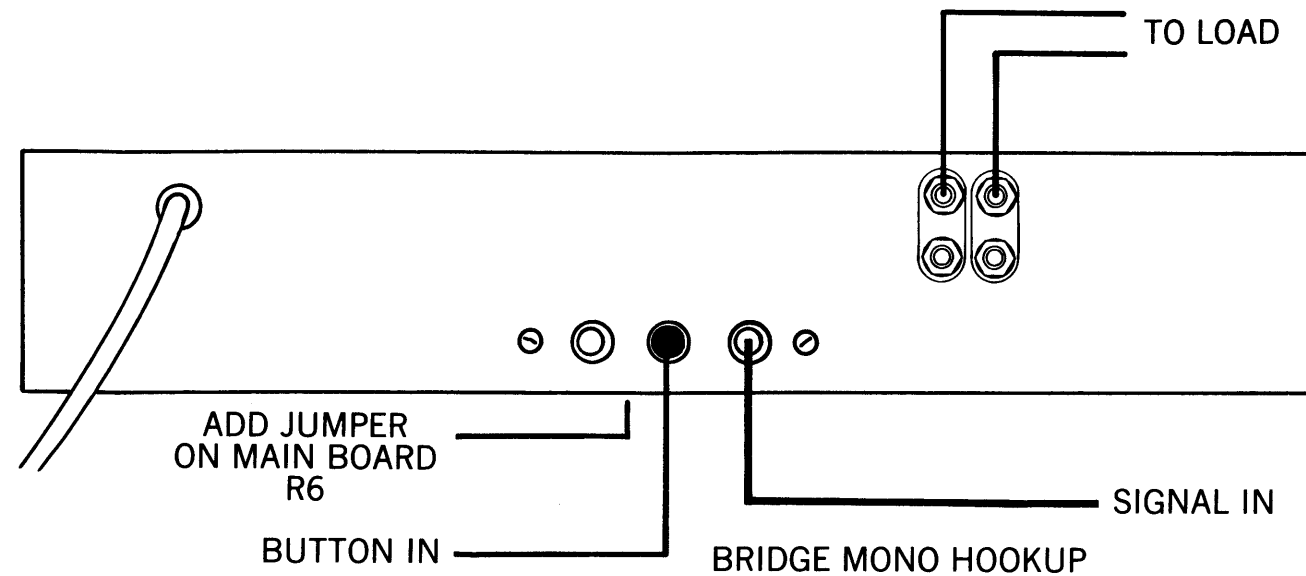

Fig. 3.6 Jumper-Wire Location for Bridge-Mono Operation

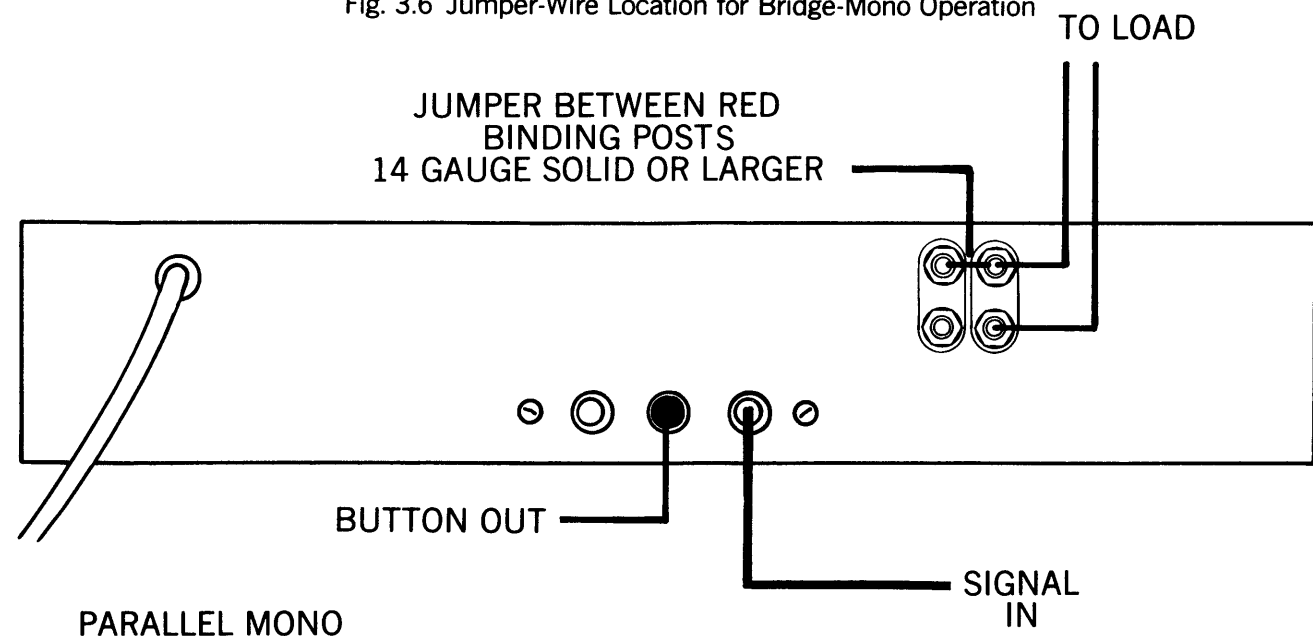

Fig. 3.7 Parallel Mono Hookup

### Parallel Mono Operation

This configuration parallels the two output channels. **Caution:** After wiring the unit for Parallel Mono, do not operate the amplifier in Stereo mode, or you may damage the amplifier.

1. On the rear panel, push out the "parallel mode" pushbutton switch.
2. Plug the input line into the Channel 1 input jack, and adjust the level with the Channel 1 input-level control only.
3. Do not use the Channel 2 input; otherwise distortion may result. Unplug the input to Channel 2 when operating in mono and turn the Channel-2 level control fully CCW.
4. Connect the output lines according to Fig. 3.7. Note the jumper between the red binding posts. Be sure to remove this jumper whenever you want to use the amplifier in 2-channel stereo mode; otherwise you may damage the amplifier.

### 3.6 Connecting Input Lines

The Micro-Tech's inputs are balanced 1/4" phone jacks. These inputs may be used either with balanced phone plugs (tip, ring, and sleeve) or with unbalanced phone plugs (tip and sleeve).

For loudspeaker-driving applications, the input should be free of large sub-sonic (low-frequency) signals, as they cause overheating and overloading of the loudspeaker. To remove such low frequencies, place a series capacitor in the input signal line. The graph of Fig. 3.8 shows how the value of the capacitor affects the frequency response. Use only a low-leakage paper, mylar, or tantalum capacitor.

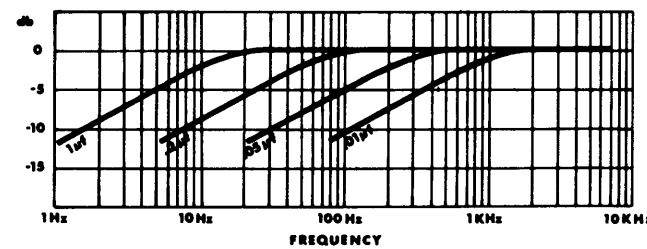

Fig. 3.8 Effect of Input-Capacitor Value on Frequency Response

If large amounts of ultrasonic or RF frequencies are found on the input, such as bias from tape recorders, etc., place a low-pass filter on the input. While practically obtainable RF input levels will not damage the amplifier, they can burn out tweeters or other sensitive loads, activate the amplifier's protective system, or overload the controlled-slewing-rate stage of the amp (which provides RF overload protection). The following filters are recommended for such applications (See Fig. 3.9).

Another problem to prevent is ground loops — undesirable currents flowing in a grounding system, possibly causing hum in the output. A common form of

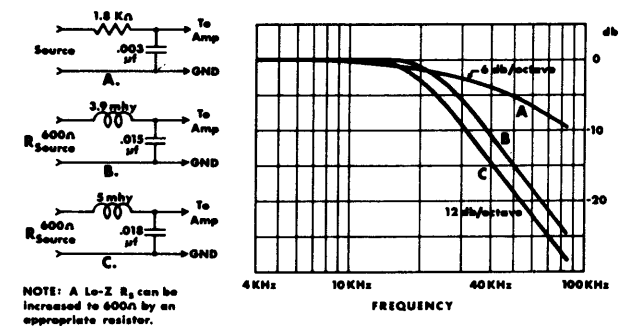

Fig. 3.9 RFI Filters

loop is a pair of input cables whose area is subjected to a magnetic hum field. To prevent ground loops caused by magnetic induction, lace both cables together along their length, and away from the power transformer. Do not connect the input and output grounds together.

A third problem (with input and output grounds tied together, as in testing or metering) is feedback oscillation from load current flowing in the loop. In industrial use, even the AC power line may provide this feedback path. Proper grounding, and isolation of inputs, of common AC-line devices is good practice.

### 3.7 Connecting Power

The Micro-Tech is furnished with a two-wire, 20A, 120V AC plug. Use a 20A wall outlet whenever possible.

Voltages above 132V may damage the +/- 15V regulator, filter capacitors and output transistors.

When testing the amplifier, the line voltage must be the RMS of the peak equivalent to a sinusoid of the indicated line voltage when at full load. Line regulation problems can reduce the available output power.

### 3.8 Control Adjustments

1. On the rear of the amplifier, turn down the input level controls (full CCW).
2. Turn on the front-panel power switch. An amber LED pilot light will come on, indicating that power has been applied. This pilot light is powered by the low-voltage power supply and is independent of the main power transformer. The pilot light will stay on even if the transformers overheat and shutdown (unless the low-voltage power supply has been damaged).
3. On the rear panel, turn the level controls all the way up (full clockwise), or for the desired loudness from your speakers.

### 3.9 The Protection Mechanisms

The Micro-Tech is protected against all common hazards that plague high-power amplifiers, including shorted, open, or mismatched loads; overloaded power supplies; excessive temperature, chain-destruction phenomena, input-overload damage, and high-frequency overload blowups. The unit protects loudspeakers from DC in the input signal.

The basic output-protection mechanism represents a dramatic departure from conventional designs. Computer analysis of transistor stress-test data, leading to the design of appropriate dynamic transistor environment analog circuits, forms the heart of the system.

A continuous flow of operating data produces an analog output proportional to the changing Safe Operating Area (SOA) of the transistor. This output controls the limits imposed by a current gain stage ahead of the output section. The output limits this change along with actual operating conditions. The maximum advantage may then be taken of the transistor's actual SOA, without the risk of destroying the device when conditions are less than ideal.

Fuses, in combination with the power transformer's thermal switch embedded in the windings, protect the power supplies against overload. If the transformers overheat, they shut off automatically, then reset after cooling to a safe temperature. To replace the AC line fuse, remove the top cover of the amplifier. The AC line fuse is 12A, 250V, type ABC.

The low-power supply and cooling fan are fused with a 1/2A, 35V type AGC fuse.

**The use of any other fuse sizes will invalidate the warranty.**

**CAUTION: NEVER CHANGE FUSES WITH THE POWER APPLIED!**

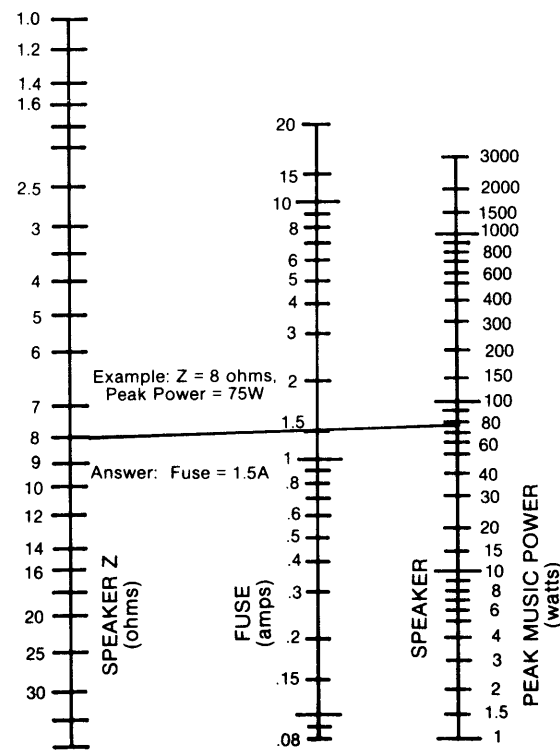

Fig. 3.10 Fuse Selector Nomograph for Loudspeaker Protection

### 3.10 Load Protection Methods

The most common way to protect loads is to put a fuse in series with the load. The fuse may be single, fusing the overall speaker system. Or it may be multiple with one fuse on each driver.

Fuses help prevent damage due to prolonged overload, but provide essentially no protection against damage from large transients. To minimize this problem, use high-speed instrument fuses such as Littlefuse 361000 series. Fig. 3.10 is a nomograph showing fuse size vs. loudspeaker ratings.

If a speaker is susceptible to damage only by overheating, the best protection scheme is a fuse or circuit breaker having the same slow thermal response as the speaker; i.e., a slow-blow fuse.

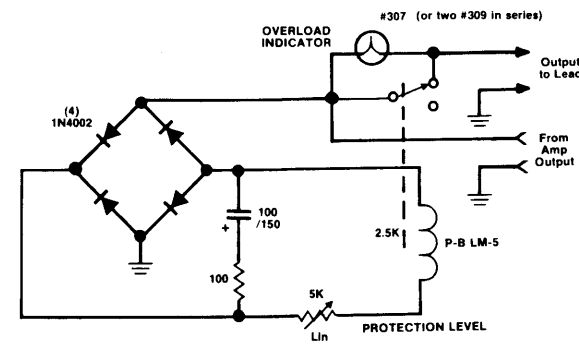

Fig. 3.11 Relay-Controlled Protector with Overload Indicator

Another form of load protector is shown schematically in Fig. 3.11. Whenever the load is overdriven, a relay switches a lamp in series with the load, smoothly relieving the overload. The lamp then doubles as an overdrive indicator as it glows. If overdrive is unreasonably severe, the lamp will serve as a fuse. By adjusting the relay tension adjustment and the protection level control, you can use this system from 20 to 200 watts for a typical 8-ohm load.

### 3.11 Cleaning

The Micro-Tech has a dust filter on the air intake to the cooling system (Fig. 3.12). If this filter becomes clogged, the unit will cool less efficiently and may produce lower-than-normal output levels due to high heat-sink temperature.

Remove the filter by pulling off the front grille. Use mild dishwashing detergent and warm water for best cleaning. Replacement filters may be ordered from the factory.

Dust filters are not 100% efficient, so you may need to clean the heat sinks eventually, especially if the

environment is dusty. The amplifier covers must be removed for adequate access. With the amplifier power off, clean the heat sinks with a vacuum cleaner or dry compressed air. Aim the compressed air directly into the heat sinks. Should the air stream strike the thin aluminum fins obliquely, they may be bent and damaged! **Use care!**



Fig. 3.12 Dust Filter



## SECTION 4 THEORY OF OPERATION

### 4.1 General Information

The Micro-Tech amplifier incorporates several new technological advancements including real-time computer simulation, a low-stress output stage, and an advanced heat-sink embodiment.

The Micro-Tech has extra circuitry to limit current and temperature to safe levels, making it highly reliable and tolerant of faults. Unlike many lesser amplifiers, it can operate at its voltage and current limits without self-destructing.

Real-time computer simulation is used to create an analog of the output devices' junction temperature, which is unmeasurable directly. Current is limited only when the device temperature becomes excessive -- and just by the minimum amount necessary. This patented approach maximizes the available output power and eliminates overheating -- the major cause of device failure.

The topology used in the Micro-Tech amplifier output stage is called "the full bridge," and makes full use of the power supply. This patented topology also provides peak-to-peak voltages available to the load that are twice the voltage the output devices are exposed to.

The full-bridge topology is ground-referenced. Composite devices are constructed to function as gigantic NPN and PNP devices, since the available currents exceed the limits of available devices. Each output stage has two of these composite NPN devices and two composite PNP devices.

The devices connected to the load are referred to as "high-side NPN and PNP" and the devices connected to ground are referred to as "low-side NPN and PNP." Positive current is delivered to the load by increasing conductance simultaneously in the high-side NPN and low-side PNP stage, while decreasing conductance of the high-side PNP and low-side NPN in synchrony.

The two channels may be used together to double the voltage or the current presented to the load. This feature gives the user flexibility in maximizing the power available to the load.

The Micro-Tech amplifier utilizes a wide-bandwidth multi-loop design that uses state-of-the-art compensation techniques. This produces ideal behavior and results in ultra-low distortion values.

Aluminum extrusions have been widely used for heat sinks in power amplifiers due to their low cost and reasonable performance. However, measured on a watts/pound basis or a watts/volume basis, the extrusion technology doesn't perform nearly as well as the heat-sink technology developed for the Micro-Tech power amplifier.

The Micro-Tech heat sinks are fabricated from custom convoluted fin stock that provides an extremely high ratio of area to volume, or area to weight. All power devices are mounted directly to massive heat spreaders that are electrically hot. Making the heat spreaders electrically hot allows improved thermal performance by eliminating the insulating interface underneath the power devices. The chassis itself is used as part of the thermal circuit, and this maximizes utilization of the available resources.

### 4.2 Block Diagram Circuit Theory

#### STEREO OPERATION

For simplicity, the discussion of stereo operation will refer to one channel only. Mono operations will be discussed later.

Please refer to the block diagram (Fig. 4.1) and the schematic.

The signal at the input jack passes into the balanced gain stage (U104-C,D) where balanced-to-single-ended conversion takes place using a difference amplifier. From there, gain can be controlled with a potentiometer. The error amp (U104-A) amplifies the difference between the output signal and the input signal from the gain pot, and drives the voltage-translator stage.

The voltage-translator stage channels the signal to the Last Voltage Amplifiers (LVA) depending on the signal

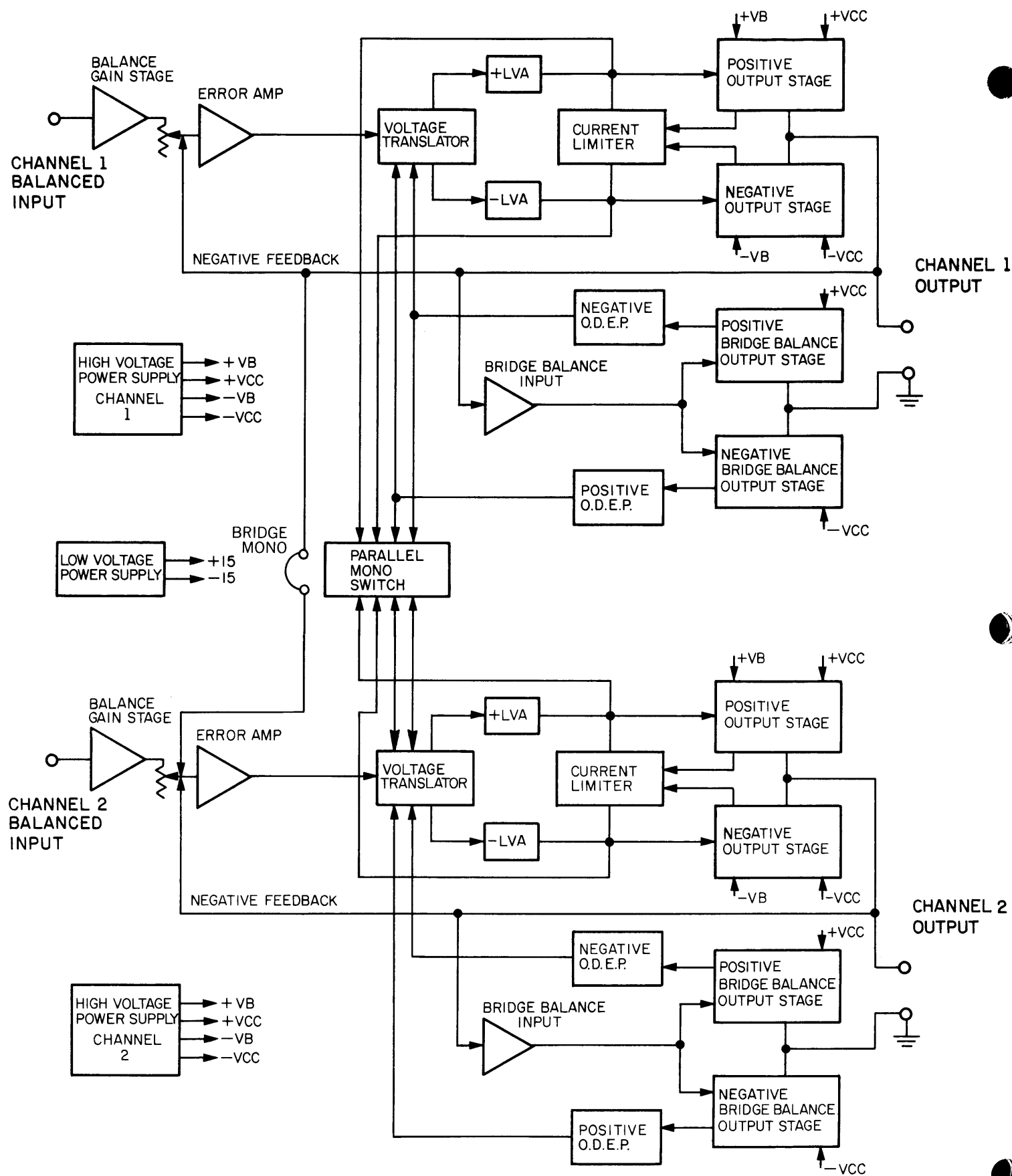

Fig. 4.1 Block Diagram

polarity from the error amp U104-A. The +LVA (Q104, Q105) and the -LVA (Q110, Q111), with their push-pull effect through the bias servo Q313, drive the fully complementary output stage.

The bias servo Q318 is thermally coupled to the heat sink, and sets the quiescent bias current in the output stage to lower the distortion in the crossover region of the output signal. D301, D302, D303, and D304 are used to remove the charge on the unused portion of the output stage, depending on the polarity of the output signal.

With the added voltage swing provided by the LVAs, the signal then gains current amplification through the three-deep Darlington emitter-follower output stage.

The bridge-balanced circuit (U104-B) receives a signal from the output of the amplifier, and differences it with the signal at the Vcc supply. The bridge-balanced circuit then develops a voltage to drive the bridge-balanced output stage. This results in the Vcc supply having exactly one half of the output voltage added to their quiescent voltage. D309, D310, D311 and a selected resistor set the quiescent current point for the bridge balanced output stage.

The protection mechanisms that affect the signal path are implemented to protect the amplifier under real-world conditions. These conditions are high instantaneous current, excessive temperature, and operation of the output devices outside safe conditions.

Q107 and Q108 act as a conventional current limiter, sensing current in the output stage. When current at any one instant exceeds the design criteria, the limiters remove the drive from the LVAs, thus limiting current in the output stage to a safe level.

To further protect the output stages, a specially developed "ODEP" circuit is used (Output Device Emulator Protection). It produces an analog output proportional to the always-changing safe-operating-area margin of the output transistor. This output controls the translator stage previously mentioned, removing any further drive that may exceed the safe-operating-area of the output stage.

Thermal sensor S100 gives the ODEP circuits vital information on the operating temperature of the heat sink on which the output devices are mounted.

### BRIDGE MONO OPERATION

By adding a jumper on the main board, the user can convert the Micro-Tech into a bridge-mono amplifier. With a signal applied to the Ch. 1 input jack, and the load between the red binding posts on the back panel, a double-voltage output occurs.

With the jumper added, the Ch. 1 output feeds the Ch. 2 error amp U204-A. Since there is a net inversion, Ch. 2 output is out-of-phase with Ch. 1. This produces twice as much voltage across the load. Each of the channels' protection mechanisms work independently if a fault occurs.

### PARALLEL MONO OPERATION

With the "parallel mono" mono button (S1) pressed out, the output of Ch. 2 is paralleled with that of Ch. 1. A suitable high-current-handling jumper must be connected across the red binding posts to gain the benefits of this mode of operation.

The signal path for Ch. 1 is the same as previously discussed, except that Ch. 1 also drives the output stage of Ch. 2. The balanced input, error amp, translators, and LVAs of Ch. 2 are disconnected and no longer control the Ch.-2 output stage. The Ch.-2 output stage and protection mechanisms are also coupled through S1 and function as one.

In PARALLEL MONO mode, twice the current of one channel alone can be obtained. Since the ODEP circuit of Ch. 2 is coupled through S1, this gives added protection if a fault occurs in the Ch. 2 output stage. The ODEP circuit of Ch. 2 will limit the output of both output stages by removing the drive from the Ch.-1 translator stages.

Each channel is powered by its own power transformer T100 or T200. Both channels share a common low-voltage transformer TF-1. The secondary output of T100 is full-wave rectified by D109 and is filtered by a large computer-grade capacitor. D104-107 provide a boosted voltage to power the LVAs and predrivers. A thermal switch embedded in each transformer protects it from overheating.

The low-voltage transformer TF-1 uses a separate winding on the fan motor. The TF-1 output, rectified by diodes D1-4, generates an unregulated 24 volts. Monolithic regulators U1-2 provide a regulated +/- 15 volts.



## SECTION 5 ACCESSORIES/OPTIONS

### 5.1 Input Sensitivity Option

The Micro-Tech is factory-set for a sensitivity of 0.775 volt in for rated power out. If desired, you can change the sensitivity to 2.2 volts in for rated power out.

The 0.775-volt sensitivity degrades the signal-to-noise specification slightly. But because of the low noise guaranteed in the Micro-Tech, the 3-5 dB of additional noise will most likely go unnoticed.

For 2.2-volt sensitivity, simply clip out R165, R166, R265 and R266. To do this, remove the bottom cover and locate the conveniently labeled parts on the main circuit board.

### 5.2 Cooling Fan Option

Your Micro-Tech comes with a built-in high-velocity fan for optimum cooling. Included in your accessory kit is a low-velocity fan that provides adequate cooling in most cases and produces less noise than the high-velocity fan.

Crown has made replacing the original fan quite simple. After removing the bottom cover, slip the original fan off the transmotor shaft and press on the low-velocity fan. The metal clip on the fan should be toward the motor. Replace the cover.

If you can hold your hand on the side of the amplifier while it's driving the desired load, it's cool enough. Otherwise, use the high-velocity fan; and, if necessary, augment the air flow with a rack-cabinet fan. If the rack fan blows air into the rack (rather than drawing air out), order a reverse-air-flow fan from Crown (Part No. C 6497-9) for your Micro-Tech. Filter the air entering the rack.



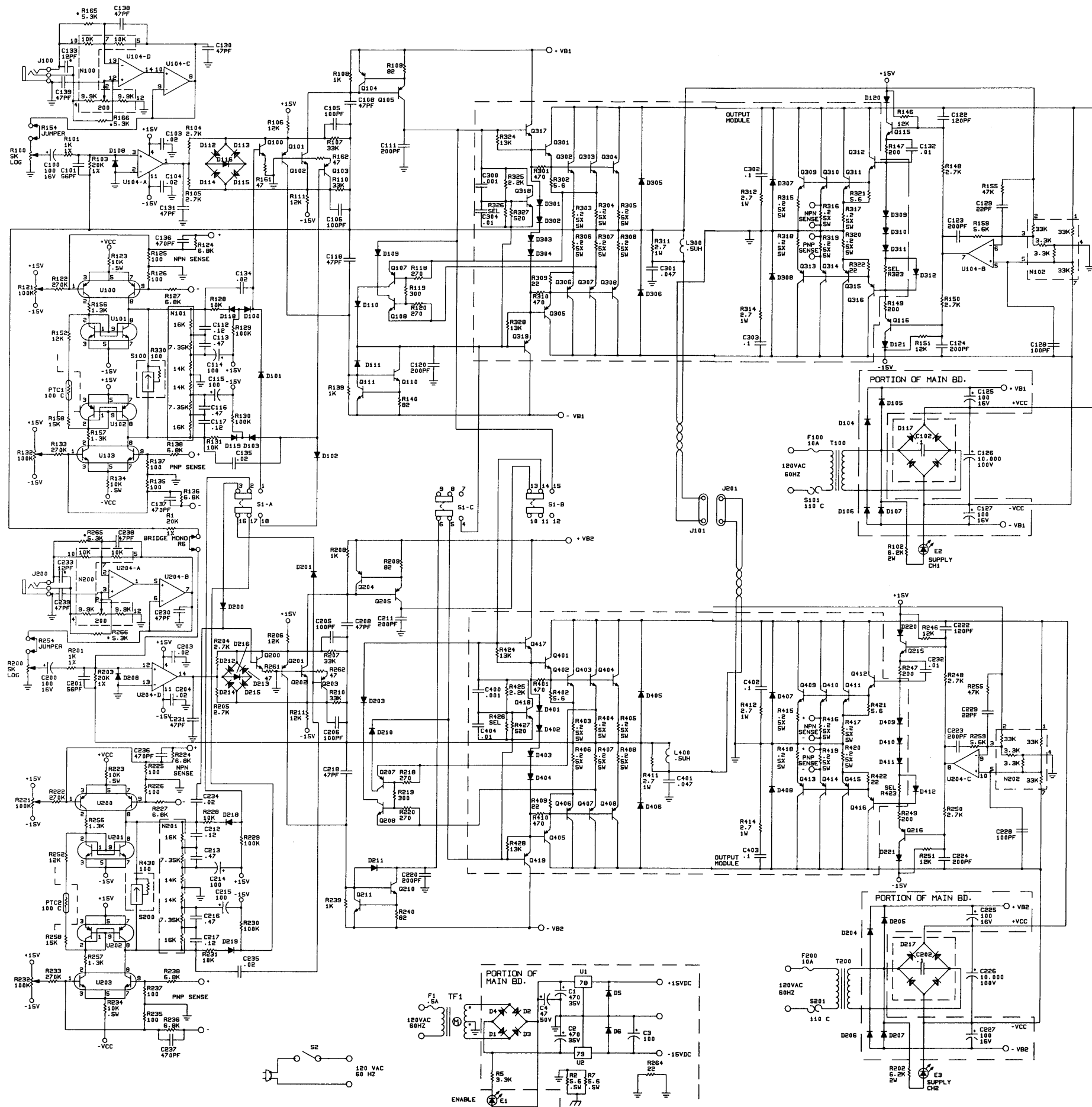

NOTES:  
 1 ALL RESISTORS ARE IN OHMS 1/4W UNLESS OTHERWISE NOTED  
 2 ALL CAPACITORS ARE IN MICROFARADS UNLESS OTHERWISE NOTED  
 \*3 USE 5.3K OHM 1% .25W MF RESISTOR FOR INPUT SENSITIVITY OF .770VRMS TO PRODUCE 250 WATTS INTO AN 8 OHM LOAD