

SERVICE MANUAL

COMPACT DISC STEREO
CASSETTE RECEIVER

BASIC TAPE MECHANISM : ZZM-2 YR1NFS
BASIC CD MECHANISM : AZG-1 ZA3RNDM

SYSTEM	CD CASSEIVER	SPEAKER	REMOTE CONTROLLER
NSX-DR4	CX-NDR4	SX-NBL11	RC-ZAS02

- This Service Manual is the "Revision Publishing" and replaces "Simple Manual" NSX-DR4(EZ), (S/M Code No. 09-007-428-8T6).
- If requiring information about the CD mechanism, see Service Manual of AZG-1 (S/M Code No. 09-001-335-3NC).

SPECIFICATIONS

<FM tuner section>

Tuning range	87.5 MHz to 108 MHz
Usable sensitivity (IHF)	16.8 dBf
Antenna terminals	75 ohms (unbalanced)

<MW tuner section>

Tuning range	530 kHz to 1710 kHz (10 kHz step) 531 kHz to 1602 kHz (9 kHz step)
Usable sensitivity	350 μ V/m
Antenna	Loop antenna

<LW tuner section>

Tuning range	144 kHz to 290 kHz
Usable sensitivity	1400 μ V/m
Antenna	Loop antenna

<Amplifier section>

Power output	Rated 12 W + 12 W (1 kHz/DIN 45500, T.H.D. 1%, 6 ohms) Reference: 15 W + 15 W (1 kHz/DIN 45324, T.H.D. 10%, 6 ohms) DIN MUSIC POWER: 30W + 30W 0.1% (6 W, 1 kHz, 6 ohms, DIN AUDIO)
Total harmonic distortion	0.1% (6 W, 1 kHz, 6 ohms, DIN AUDIO)
Inputs	VIDEO/AUX: 500 mV
Outputs	SPEAKERS: accept speakers of 6ohms or more PHONES (stereo jack) : accepts headphones of 32 ohms or more

<Cassette deck section>

Track format	4 tracks, 2 channels stereo
Frequency response	50 Hz - 8000 Hz
Recording system	AC bias
Heads	Deck 1 : Recording/Playback head x 1, erase head x 1 Deck 2 : Playback head x 1

<Compact disc player section>

Laser	Semiconductor laser (λ =780 nm)
D-A converter	1 bit dual
Signal-to-noise ratio	85 dB (1 kHz, 0 dB)
Harmonic distortion	0.05 % (1 kHz, 0 dB)

<Speaker system>SX-NBL11

Speaker System	2 way, bass reflex (magnetic shielded type)
Speaker units	Woofer: 120 mm cone type Tweeter: 20 mm ceramic type
Impedance	6 ohms
Sensitivity	87 dB/W/m
Dimensions (W x H x D)	220 x 324 x 211 mm
Weight	2.0 kg

<General>

Power requirements	230 V AC, 50 Hz
Power consumption	45 W
Power consumption in standby mode	With power-economizing mode off : 14 W With power-economizing mode on : 0.9 W
Dimensions of main unit (W x H x D)	260 x 324 x 348 mm
Weight of main unit	4.9 kg

• Design and specifications are subject to change without notice.

PROTECTION OF EYES FROM LASER BEAM DURING SERVICING

This set employs laser. Therefore, be sure to follow carefully the instructions below when servicing.

WARNING!!

WHEN SERVICING, DO NOT APPROACH THE LASER EXIT WITH THE EYE TOO CLOSELY. IN CASE IT IS NECESSARY TO CONFIRM LASER BEAM EMISSION. BE SURE TO OBSERVE FROM A DISTANCE OF MORE THAN 30cm FROM THE SURFACE OF THE OBJECTIVE LENS ON THE OPTICAL PICK-UP BLOCK.

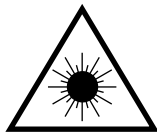

- Caution: Invisible laser radiation when open and interlocks defeated avoid exposure to beam.
- Advarsel: Usynlig laserstråling ved åbning, når sikkerhedsafbrydere er ude af funktion. Undgå udsættelse for stråling.

VAROITUS!

Laiteen Käyttäminen muulla kuin tässä käyttöohjeessa mainitulla tavalla saattaa altistaa käyt-täjän turvallisuusluokan 1 ylittävälle näkymättömälle lasersäteilylle.

WARNING!

Om apparaten används på annat sätt än vad som specificeras i denna bruksanvising, kan användaren utsättas för osynlig laserstrålning, som överskrider gränsen för laserklass 1.

CAUTION

Use of controls or adjustments or performance of procedures other than those specified herein may result in hazardous radiation exposure.

ATTENTION

L'utilisation de commandes, réglages ou procédures autres que ceux spécifiés peut entraîner une dangereuse exposition aux radiations.

ADVARSEL

Usynlig laserstråling ved åbning, når sikkerhedsafbrydere er ude af funktion. Undgå udsættelse for stråling.

This Compact Disc player is classified as a CLASS 1 LASER product.

The CLASS 1 LASER PRODUCT label is located on the rear exterior.

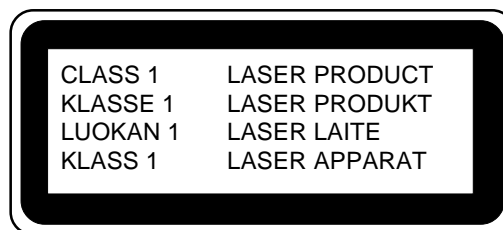

Precaution to replace Optical block

(KSS-213F)

Body or clothes electrostatic potential could ruin laser diode in the optical block. Be sure ground body and workbench, and use care the clothes do not touch the diode.

- 1) After the connection, remove solder shown in right figure.

PICK-UP ASSY
P.C.B

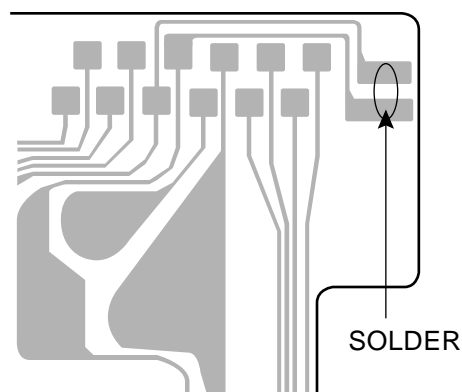

NOTE ON BEFORE STARTING REPAIR

1. Forced discharge of electrolytic capacitor of power supply block

When repair is going to be attempted in the set that uses relay circuit in the power supply block, electric potential is kept charged across the electrolytic capacitors (C101, 102) even though AC power cord is removed. If repair is attempted in this condition, secondary defect can occur.

In order to prevent the secondary trouble, perform the following measures before starting repair work.

Discharge procedure

- ① Remove the AC power cord.
- ② Connect a discharging resistor at an end of lead wire that has clips at both ends. Connect the other end of the lead wire to metal chassis.
- ③ Contact the other end of the discharging resistor to the positive (+) side (+VH) of C101. (For two seconds)
- ④ Contact the same end of the discharging resistor as step ③ to the negative (-) side (-VH) of C102 in the same way. (For two seconds)
- ⑤ Check that voltage across C101 and C102 has decreased to 1 V or less using a multimeter or an oscilloscope.

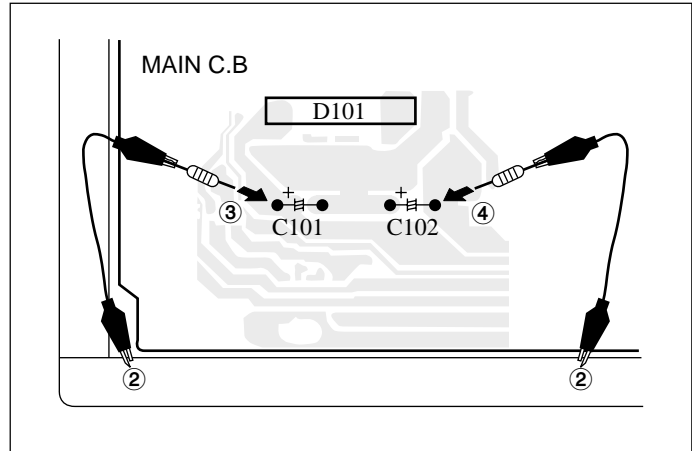

Fig-1

Select a discharging resistor referring to the following table.

Charging voltage (V) (C101, 102)	Discharging resistor (Ω)	Rated power (W)	Parts number
25-48	100	3	87-A00-247-090
49-140	220	5	87-A00-232-090

Note: The reference numbers (C101, C102) of the electrolytic capacitors can change depending on the models. Be sure to check the reference numbers of the charging capacitors on schematic diagram before starting the discharging work.

2. Check items before exchanging the MICROCOMPUTER

Be sure to check the following items before exchanging the MICROCOMPUTER. Exchange the MICROCOMPUTER after confirming that the MICROCOMPUTER is surely defective.

2-1. Regarding the HOLD terminal of the MICROCOMPUTER

When the HOLD terminal (INPUT) of the MICROCOMPUTER is "H", the MICROCOMPUTER is judged to be operating correctly. When this terminal is "L", the main power cannot be turned on. Therefore, be sure to check the terminal voltage of the HOLD terminal before exchange.

When the MICROCOMPUTER is not defective, the HOLD terminal can also go "L" when the POWER AMPLIFIER has any abnormalities that triggers the abnormality detection circuit on the MAIN C. B. that sets the HOLD terminal to "L".

- Good or no good judgement of the MICROCOMPUTER

- ① Turn on the AC main power.
- ② Confirm that the main power is turned on and the HOLD terminal of the MICROCOMPUTER keeps the "H" level or not.
- ③ When the HOLD terminal is "L" level, the abnormality detection circuit is judged to be working correctly and the MICROCOMPUTER is judged to be good.

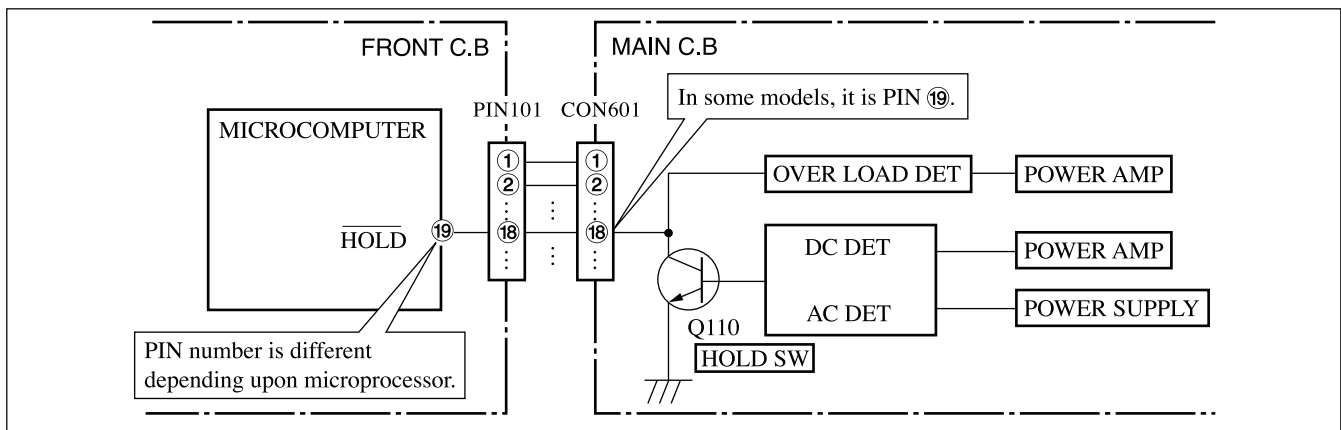

Fig-2-1

In such a case, check also if the POWER AMPLIFIER circuit or power supply circuit has any abnormalities or not.

2-2. Regarding reset

There are cases that the machine does not work correctly because the MICROCOMPUTER is not reset even though the AC power cord is re-inserted, or the software reset (pressing the STOP key + POWER key) is performed.

When the above described phenomenon occurs, it can lead to wrong judgement as if the MICROCOMPUTER is defective and to exchange the MICROCOMPUTER. In such a case, perform the forced-reset by the following procedure and check good or no good of the MICROCOMPUTER.

- ① Remove the AC power cord.

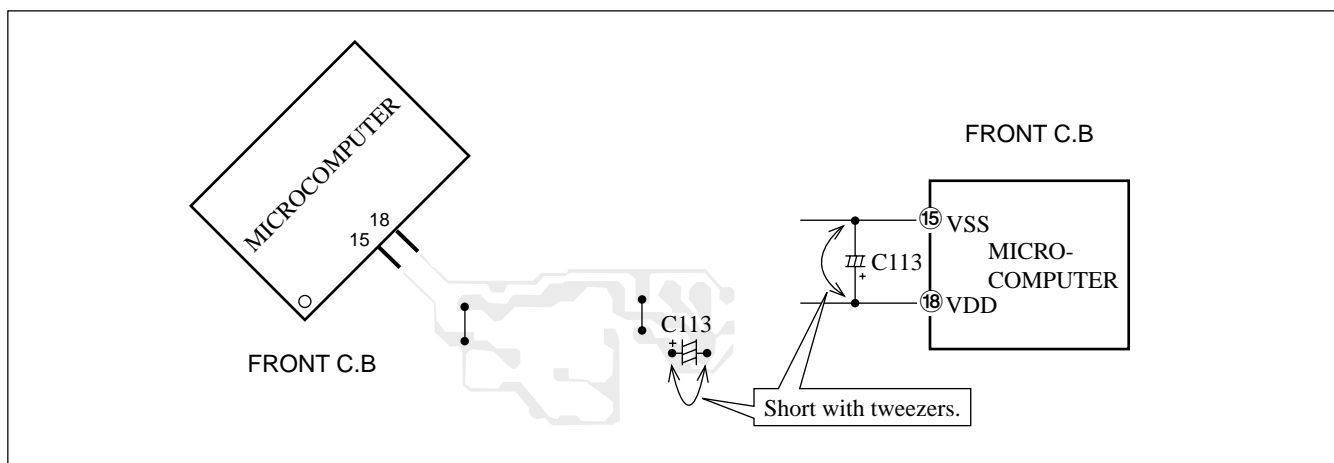

Fig-2-2

- ② Short both ends of the electrolytic capacitor C113 that is connected to VDD of the MICROCOMPUTER with tweezers.
- ③ Connect the AC power cord again. If the MICROCOMPUTER returns to the normal operation, the MICROCOMPUTER is good.

Note: The reference number or MICROCOMPUTER pin number of transistor (Q110) and electrolytic capacitor (C113) can change depending on the models. Be sure to check the reference numbers on schematic diagram before starting the discharging work.

2-3. Confirmation of soldering state of MICROCOMPUTER

Check the soldering state of the MICROCOMPUTER in addition to the above described procedures. Be sure to exchange the MICROCOMPUTER after surely confirming that the trouble is not caused by poor soldering but the MICROCOMPUTER itself.

ELECTRICAL MAIN PARTS LIST

REF. NO.	PART NO.	KANRI NO.	DESCRIPTION	REF. NO.	PART NO.	KANRI NO.	DESCRIPTION
IC							
	8A-NFA-615-010		C-IC, M38B57MCH-E236FP	C106	87-010-186-080		CAP, CHIP 4700P
	87-A21-419-040		C-IC, NJM14558MD-TE2	C107	87-010-403-080		CAP, ELECT 3.3-50V
	87-A21-443-040		C-IC, M62495AFP	C108	87-010-403-080		CAP, ELECT 3.3-50V
	87-A21-560-010		IC, LA1844L-A	C109	87-010-322-080		C-CAP, S 100P-50JCH
	87-070-127-110		IC, LC72131 D	C110	87-010-322-080		C-CAP, S 100P-50JCH
	87-A21-629-010		IC, SPS-442-10N	C111	87-010-406-080		CAP, ELECT 22-50
	87-A21-482-010		IC, RPM6938-H4	C112	87-010-406-080		CAP, ELECT 22-50
				C113	87-012-156-080		C-CAP, S 220P-50 J CH
				C114	87-012-156-080		C-CAP, S 220P-50 J CH
				C119	87-010-197-080		CAP, CHIP 0.01 DM
TRANSISTOR							
	87-026-609-080		TR, KTA1266GR	C120	87-010-197-080		CAP, CHIP 0.01 DM
	89-213-702-010		TR, 2SB1370E	C123	87-010-197-080		CAP, CHIP 0.01 DM
	87-026-610-080		TR, KTC3198GR	C124	87-010-197-080		CAP, CHIP 0.01 DM
	87-A30-076-080		C-TR, 2SC3052F	C125	87-010-196-080		CHIP CAPACITOR, 0.1-25
	87-A30-075-080		C-TR, 2SA1235F	C126	87-010-196-080		CHIP CAPACITOR, 0.1-25
	87-A30-255-010		C-TR, 2SB1342	C127	87-010-196-080		CHIP CAPACITOR, 0.1-25
	87-A30-256-010		TR, 2SD1933	C128	87-010-196-080		CHIP CAPACITOR, 0.1-25
	87-A30-090-080		FET, 2SK2541	C133	87-010-186-080		CAP, CHIP 4700P
	87-A30-484-080		C-TR, KRA102S	C1P200T	0.000T		
	87-A30-468-080		C-TR, KRC102S-RTK				
	87-A30-107-070		C-TR, CMBT5401				
	87-A30-106-040		C-TR, CMBT5551				
	87-A30-091-080		FET, 2SJ460				
	87-A30-062-080		C-TR, KRC104S				
	87-A30-234-080		TR, CSC4115BC				
	87-A30-492-080		TR, 2SC5343G				
	89-327-143-080		TR, 2SC27140				
	87-A30-489-080		C-TR, KRA107S				
	87-A30-495-080		TR, 2SA1981Y				
DIODE							
	87-020-465-080		DIODE, 1SS133 (110MA)				
	87-A40-455-080		DIODE, RL203 GW				
	87-A40-553-080		DIODE, 1N4003 LES				
	87-A40-774-080		ZENER, UZ24BSD				
	87-A40-764-080		ZENER, UZ10BSC				
	87-A40-270-080		C-DIODE, MC2838				
	87-A40-269-080		C-DIODE, MC2836				
	87-A40-752-080		ZENER, UZ6.2BSC				
	87-A40-739-080		ZENER, UZ2.7BSA				
	87-017-149-080		ZENER, HZS6A2L				
MAIN C.B							
C9	87-010-196-080		CHIP CAPACITOR, 0.1-25				
C10	87-010-196-080		CHIP CAPACITOR, 0.1-25				
C11	87-010-196-080		CHIP CAPACITOR, 0.1-25				
C12	87-010-196-080		CHIP CAPACITOR, 0.1-25				
C21	87-A10-520-000		CAP, E 3300-35 M SMG				
C22	87-016-051-000		CAP, E 2200-35 SMG				
C25	87-010-407-080		CAP, ELECT 33-50 M 11L SME				
C26	87-010-406-080		CAP, ELECT 22-50				
C30	87-010-384-080		CAP, ELECT 100-25M11LSME				
C31	87-010-263-080		CAP, ELECT 100-10V				
C32	87-010-197-080		CAP, CHIP 0.01 DM				
C34	87-010-380-080		CAP, ELECT 47-16				
C35	87-010-406-080		CAP, ELECT 22-50				
C36	87-010-381-080		CAP, ELECT 330-16V				
C38	87-010-190-080		C-CAP, S 0.01-50 ZF				
C50	87-010-384-080		CAP, ELECT 100-25 M 11L SME				
C60	87-010-403-080		CAP, ELECT 3.3-50V				
C61	87-010-380-080		CAP, ELECT 47-16				
C100	87-018-127-080		CAP TC-U 470P				
C101	87-010-185-080		C-CAP, S 3900P-50 KB				
C102	87-010-185-080		C-CAP, S 3900P-50 KB				
C103	87-010-545-080		CAP, ELECT 0.22-50V				
C104	87-010-545-080		CAP, ELECT 0.22-50V				
C105	87-010-186-080		CAP, CHIP 4700P				

REF. NO.	PART NO.	KANRI NO.	DESCRIPTION	REF. NO.	PART NO.	KANRI NO.	DESCRIPTION
C118	87-A10-189-040		CAP,E 220-10	S322	87-A90-164-080		SW,TACT SKQAB(N)
C119	87-A10-189-040		CAP,E 220-10	S323	87-A90-164-080		SW,TACT SKQAB(N)
C120	87-012-156-080		C-CAP,S 220P-50 CH	S324	87-A90-164-080		SW,TACT SKQAB(N)
C123	87-010-196-080		CHIP CAPACITOR,0.1-25	S325	87-A90-164-080		SW,TACT SKQAB(N)
C124	87-010-196-080		CHIP CAPACITOR,0.1-25	S326	87-A90-164-080		SW,TACT SKQAB(N)
C125	87-010-405-040		CAP,E 10-50	S327	87-A90-164-080		SW,TACT SKQAB(N)
C126	87-010-196-080		CHIP CAPACITOR,0.1-25	S328	87-A90-164-080		SW,TACT SKQAB(N)
C129	87-010-374-040		CAP,E 47-10	S329	87-A90-164-080		SW,TACT SKQAB(N)
C210	87-012-156-080		C-CAP,S 220P-50 CH	S330	87-A90-164-080		SW,TACT SKQAB(N)
C212	87-010-404-040		CAP,E 4.7-50 SME	S331	87-A90-164-080		SW,TACT SKQAB(N)
C213	87-010-404-040		CAP,E 4.7-50 SME	SFR701	87-024-431-080		SFR,3.3K RH063EC
C701	87-010-384-040		CAP,E 100-25 SME				
C702	87-010-178-080		C-CAP,S1000P-50KB				
CN101	87-099-720-010		CONN,30P TYK-B(P)	PT C.B			
CN701	87-A60-673-010		CONN,9P H 2MM JMT				
CN801	87-099-015-010		CONN,13P 6216V	C183	87-010-387-080		CAP, ELECT 470-25 M
FL201	8A-NFA-604-010		FL,10-BT-224GNK	C184	87-010-403-080		CAP, ELECT 3.3-50V
L101	87-A50-434-010		COIL,CLK 4.19M(TOKO)	C185	87-018-209-080		CAP, TC U 0.1-50 ZF
LED101	87-A40-317-080		LED,SLR-342VCT31 RED	△ PT1	8A-NFA-608-010		PT,ANF-A EZ
S101	87-A91-555-010		SW,RTRY EC12E24504	△ PT181	8A-NF8-662-010		PT,SUB ANF-8 (E)
S301	87-A90-164-080		SW,TACT SKQAB(N)	△ RY181	87-A90-976-010		RELAY,AC12V SDT-S-112LMR
S302	87-A90-164-080		SW,TACT SKQAB(N)	△ T181	87-A60-317-010		TERMINAL, 1P MSC
S303	87-A90-164-080		SW,TACT SKQAB(N)	△ T182	87-A60-317-010		TERMINAL, 1P MSC
S304	87-A90-164-080		SW,TACT SKQAB(N)	△ WH181	87-A90-460-010		HLDR,WIRE 2.5-7P
S305	87-A90-164-080		SW,TACT SKQAB(N)				
S306	87-A90-164-080		SW,TACT SKQAB(N)				
S307	87-A90-164-080		SW,TACT SKQAB(N)				
S308	87-A90-164-080		SW,TACT SKQAB(N)				
S309	87-A90-164-080		SW,TACT SKQAB(N)				
S321	87-A90-164-080		SW,TACT SKQAB(N)				

○チップ抵抗部品コード／

チップ抵抗部品コードの成り立ち

Chip Resistor Part Coding

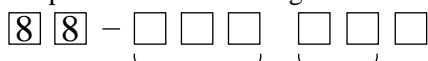

抵抗部品コード
Resistor Code

Figure

Value of resistor

Chip resistor

Wattage	Type	Tolerance		Form			
				L	W	t	
1/16W	1608	5%	CJ	1.6	0.8	0.45	108
1/10W	2125	5%	CJ	2	1.25	0.45	118
1/8W	3216	5%	CJ	3.2	1.6		128

TRANSISTOR ILLUSTRATION

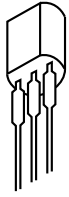

E C B

CSC4115
KTA1266
KTC3198

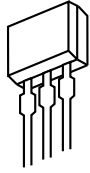

S D G

2SJ460
2SK2541



B C E

2SB1342
2SB1370
2SD1933

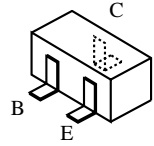

2SA1235	KRA102
2SC2714	KRA107
2SC3052	KRC102
CMBT5401	KRC104
CMBT5551	



E B C

2SA1981









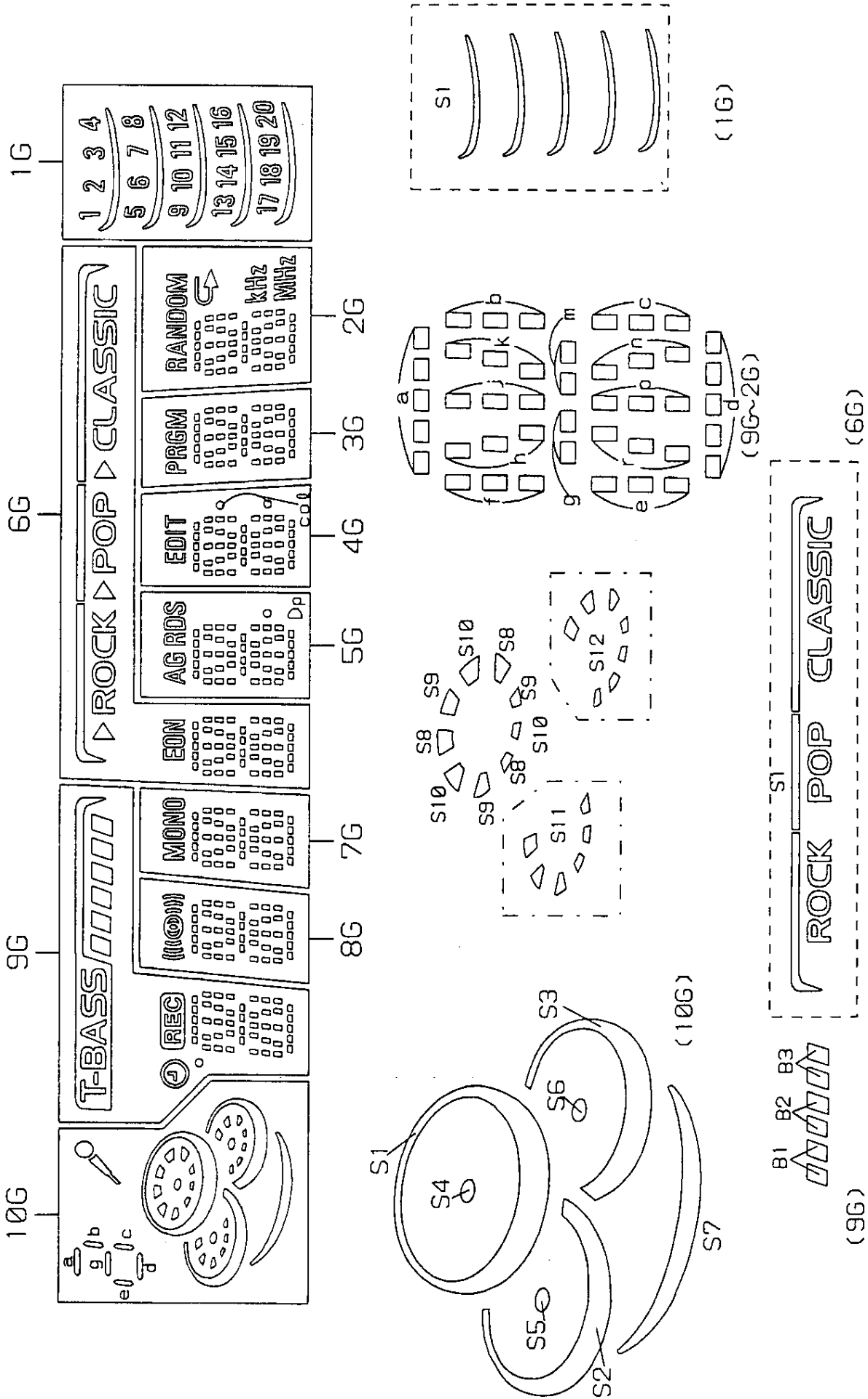



E C B

2SC5343

FL (10-BT-224GNK) GRID ASSIGNMENT AND ANODE CONNECTION
 GRID ASSIGNMENT



ANODE CONNECTION

	10G	9G	8G	7G	6G	5G	4G	3G	2G	1G
P1	-	d	d	d	d	d	d	d	d	20
P2	S7	n	n	n	n	n	n	n	n	19
P3	-	p	p	p	p	p	p	p	p	18
P4	S11	r	r	r	r	r	r	r	r	17
P5	S5	e	e	e	e	e	e	e	e	16
P6	S2	c	c	c	c	c	c	c	c	15
P7	S12	g	g	g	g	g	g	g	g	14
P8	S6	m	m	m	m	m	m	m	m	13
P9	S3	f	f	f	f	f	f	f	f	12
P10	S10	b	b	b	b	b	b	b	b	11
P11	S9	k	k	k	k	k	k	k	k	10
P12	S8	j	j	j	j	j	j	j	j	9
P13	S4	h	h	h	h	h	h	h	h	8
P14	S1	a	a	a	a	a	a	a	a	7
P15	-				Dp	col (F)	col (F)	-	MHZ	6
P16	-		-	-	AG	col (H)	col (H)	-	KHZ	5
P17			-	-	RDS	EDIT	PRGM	PRGM		4
P18	a, d, g		-	-	-	-	-	-	-	3
P19	b	B1	-	-	 (CLASSIC)	-	-	-	-	2
P20	c	B2	-	-	 (ROCK)	-	-	-	-	1
P21	e	B3	-	-	 (POP)	S1	-	-	RANDOM	S1

WIRING - 1 (MAIN)

32 | 31 | 30 | 29 | 28 | 27 | 26 | 25 | 24 | 23 | 22 | 21 | 20 | 19 | 18 | 17 | 16 | 15 | 14 | 13 | 12 | 11 | 10 | 9 | 8 | 7 | 6 | 5 | 4 | 3 | 2 | 1

TO CD MECHANISM AZG-1



↓
CN602

A MAIN C.B

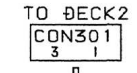

↓
TO CN301

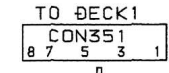

↓
TO CN351



A
B
C
D
E
F
G
H
I
J
K
L
M
N
O
P
Q
R
S
T
U

SCHEMATIC DIAGRAM-1 (MAIN 1/2 : AMP SECTION)

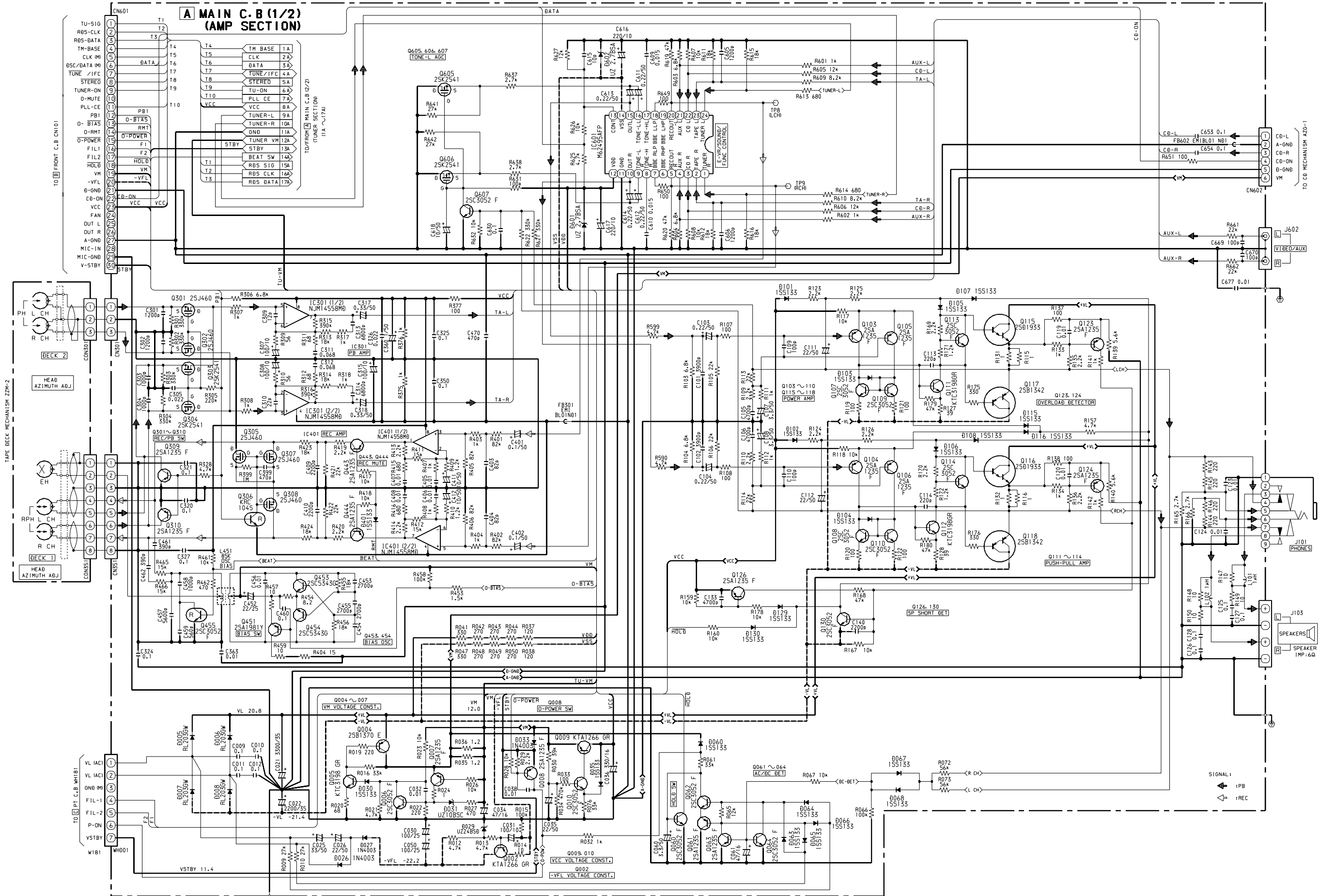

SCHEMATIC DIAGRAM-2 (MAIN 2/2 : TUNER SECTION)

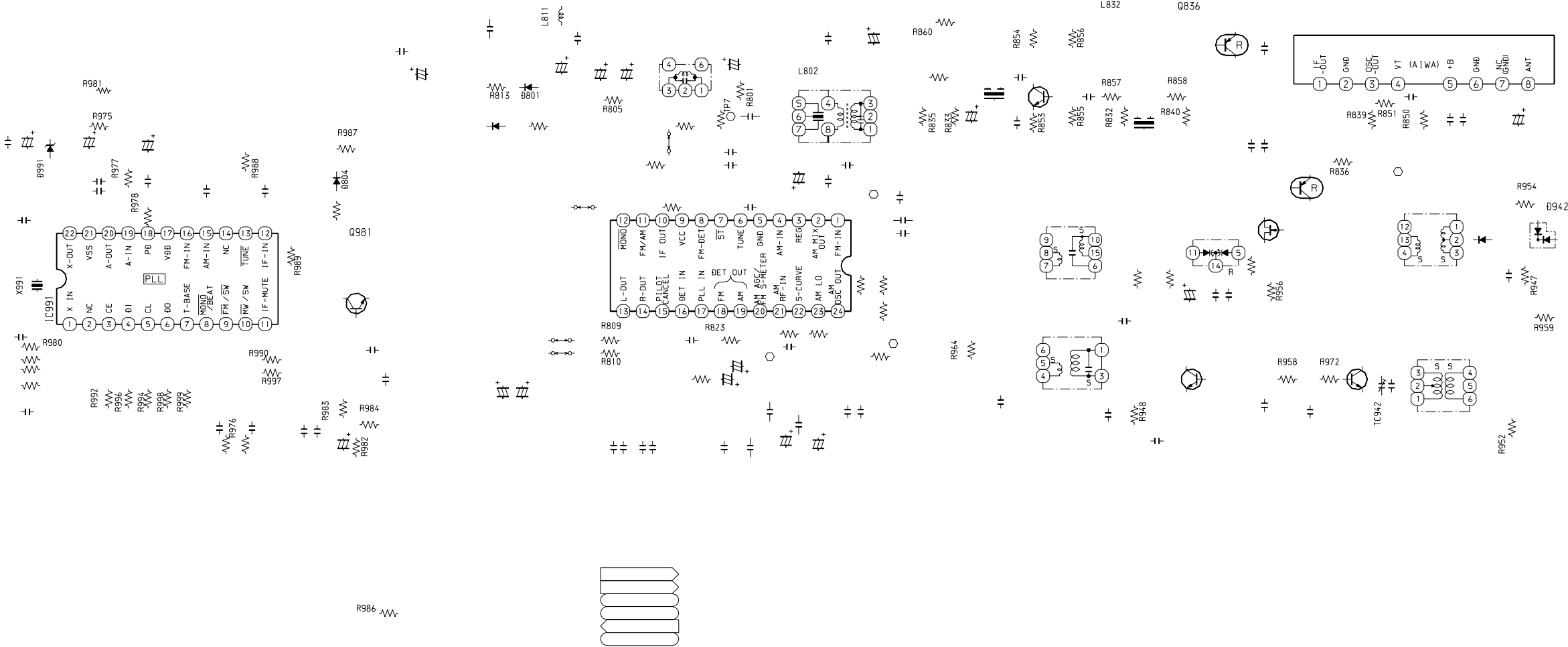
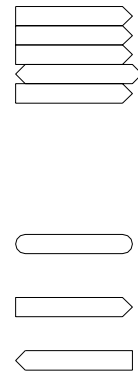

TO CD MECHANISM AZG-1

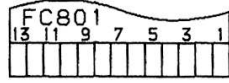

B FRONT C.B

FL201 (DISPLAY)

LED101 (STANDBY)

IC102 (REMOTE SENSOR)

S301 (POWER)

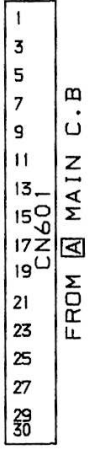
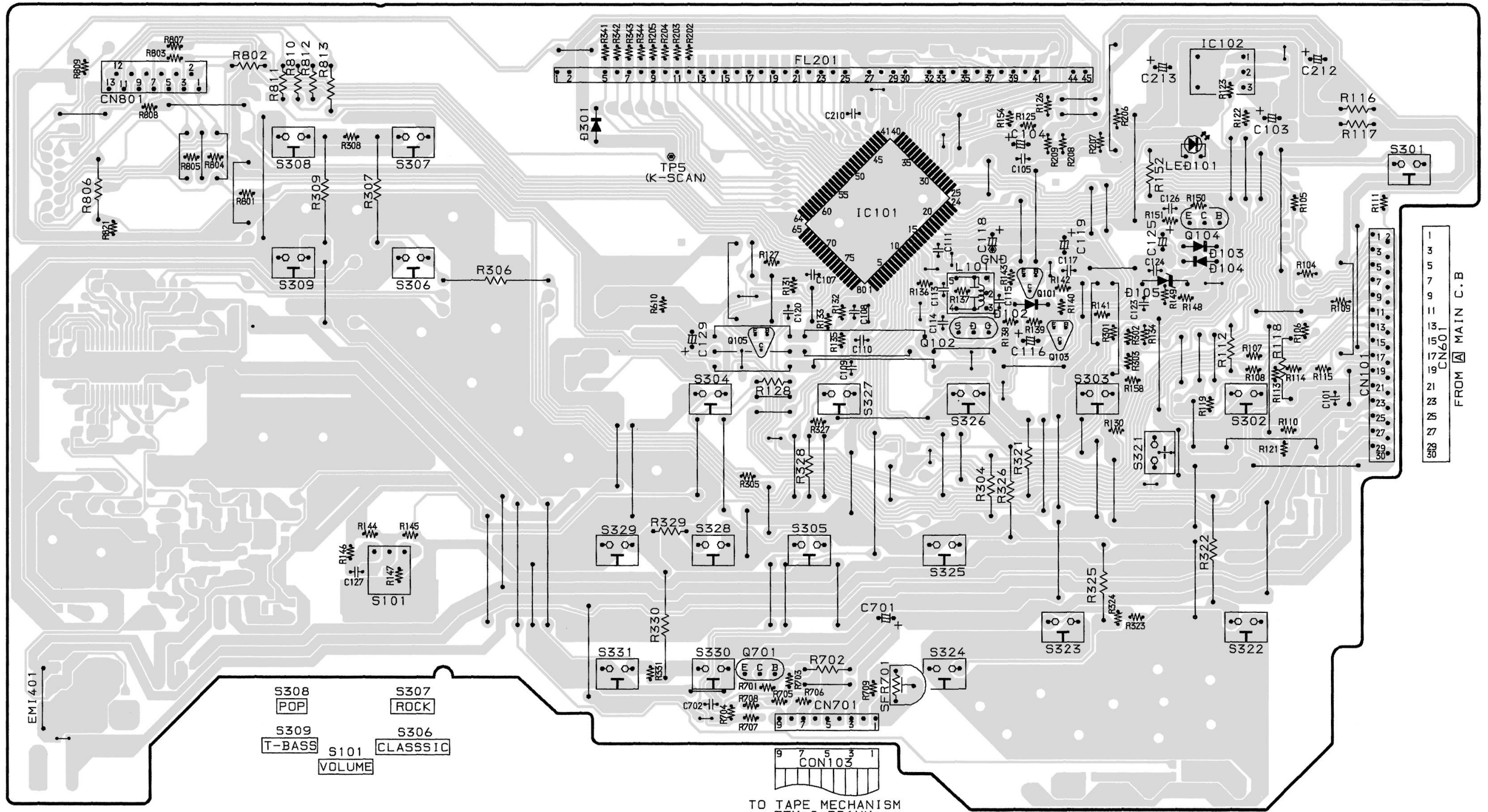

TO TAPE MECHANISM ZZM-2 PR1NM

- S308 POP
- S307 ROCK
- S309 T-BASS
- S306 CLASSIC
- S101 VOLUME

- S304 CD
- S327 VIDEO/AUX
- S326 TUNER/BAND
- S303 TAPE
- S302 ECO
- S329 PRESET
- S328 CLEAR
- S305 SET
- S325 DISC/CHANGE
- S321, 322, 323 DISC DIRECT PLAY 1-3
- S331 UP
- S330 DOWN
- S324 OPEN/CLOSE

SCHEMATIC DIAGRAM-3 (FRONT)

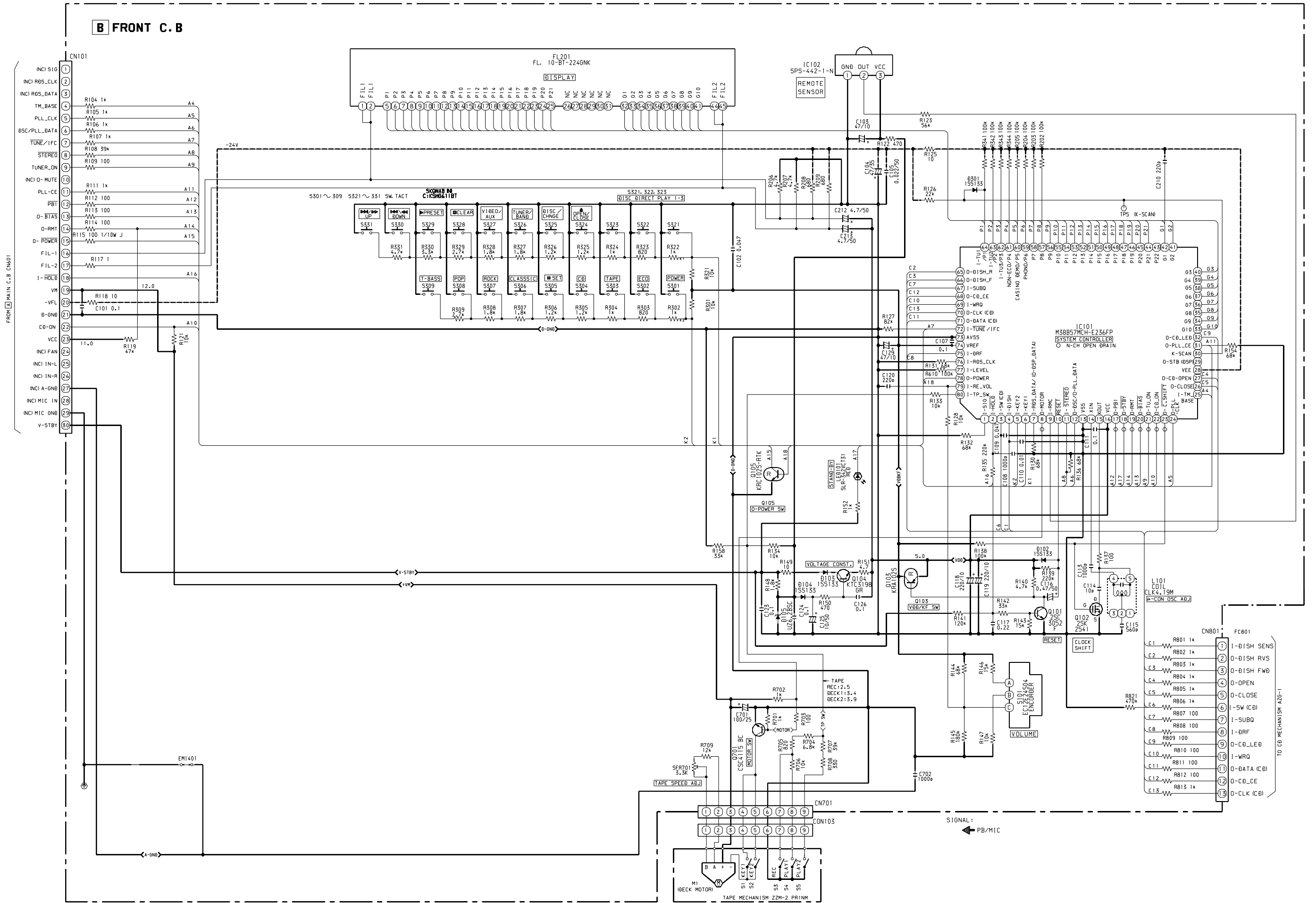

WIRING - 3 (PT)

15	14	13	12	11	10	9	8	7	6	5	4	3	2	1
----	----	----	----	----	----	---	---	---	---	---	---	---	---	---

C PT C.B

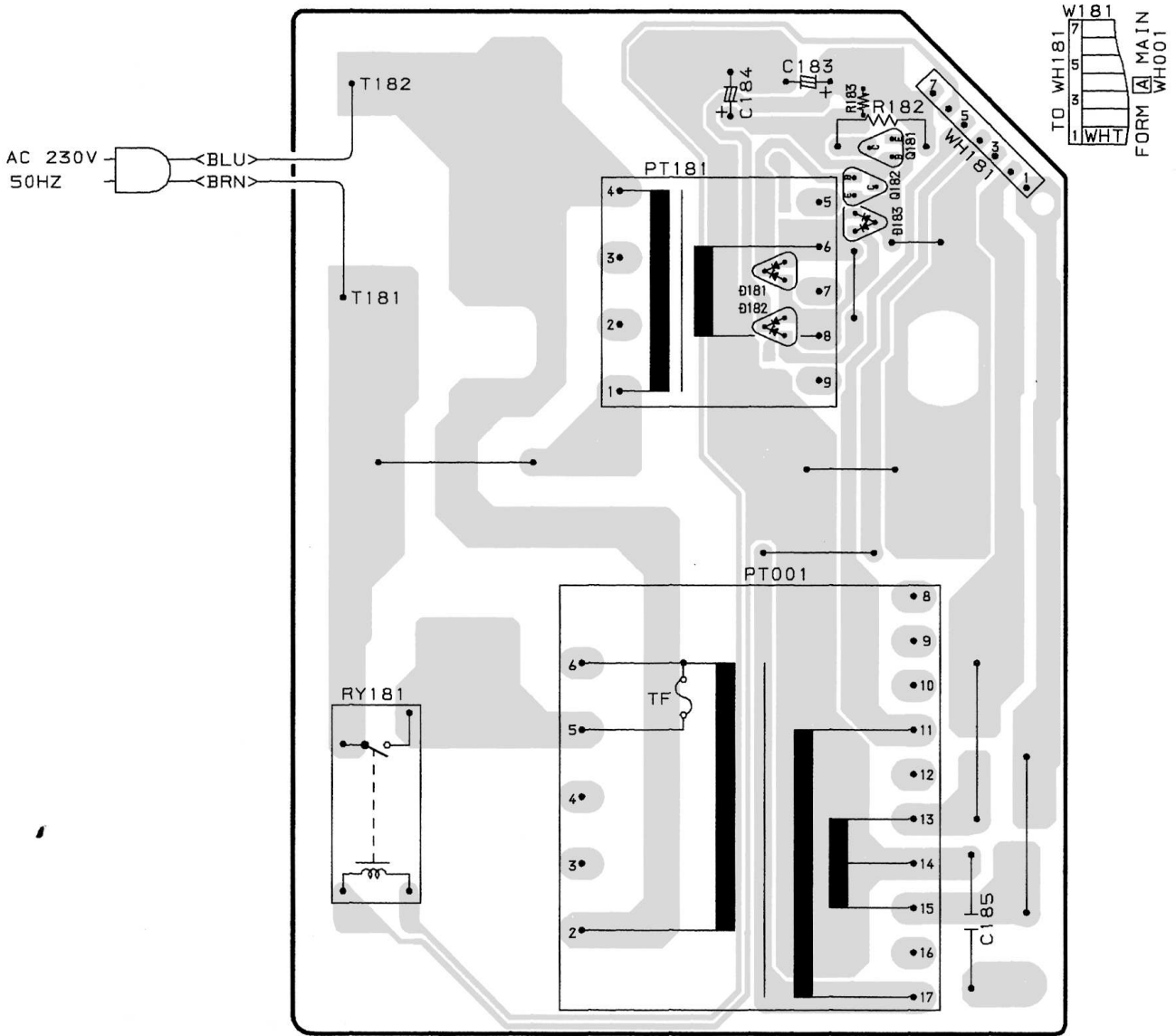

A
B
C
D
E
F
G
H
I
J
K
L
M
N
O
P
Q
R
S
T
U

SCHEMATIC DIAGRAM-4 (PT)

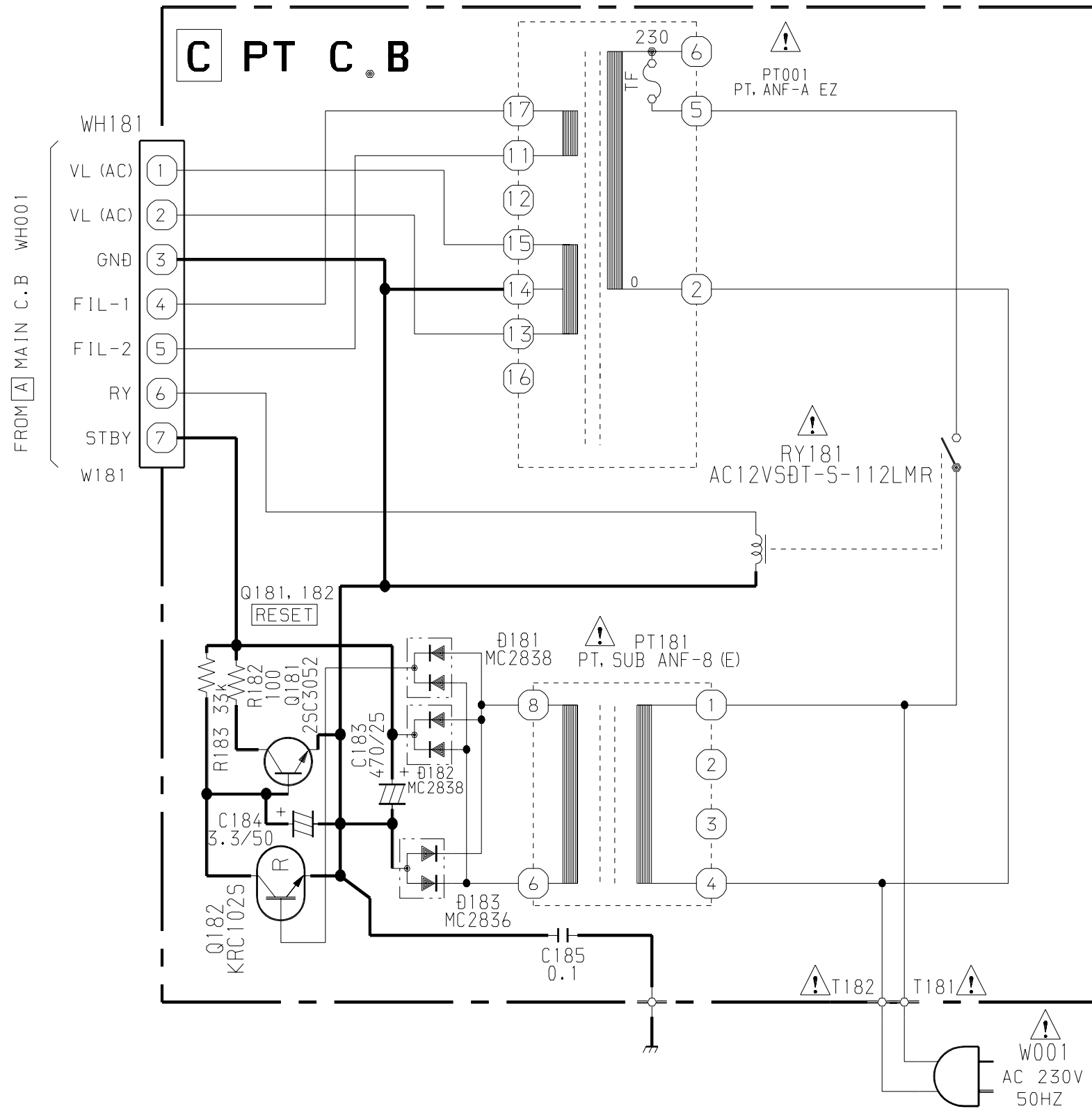

WIRING - 4 (DECK)

15	14	13	12	11	10	9	8	7	6	5	4	3	2	1
----	----	----	----	----	----	---	---	---	---	---	---	---	---	---

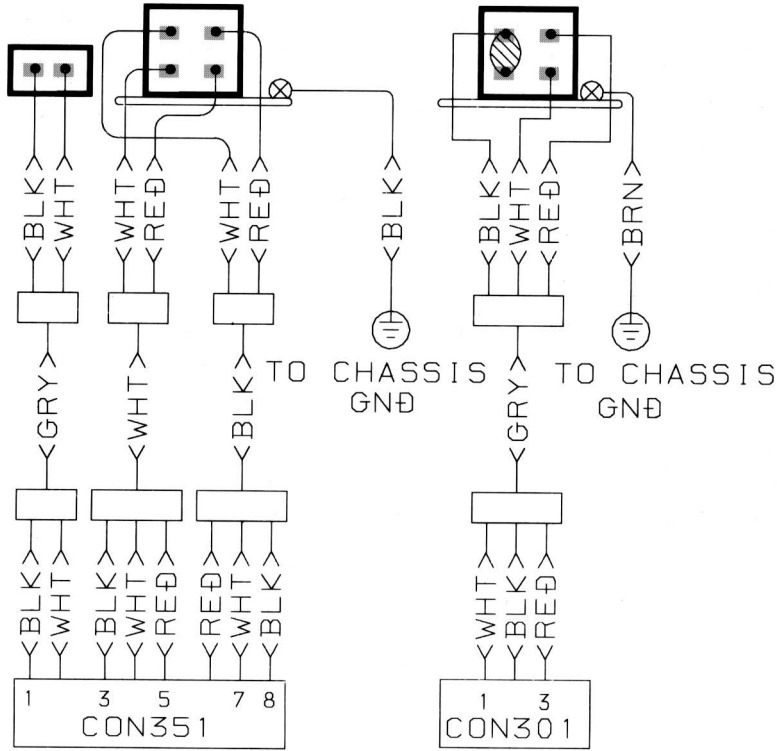
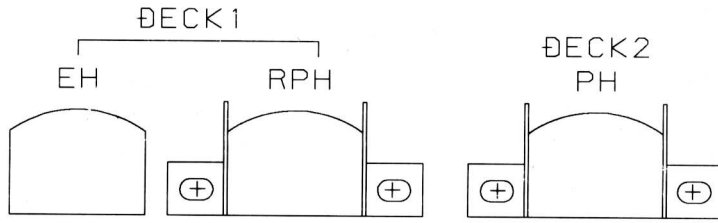

FROM [A] MAIN C.B.
CN351

FROM [A] MAIN C.B.
CN301

M1
(DECK MOTOR)

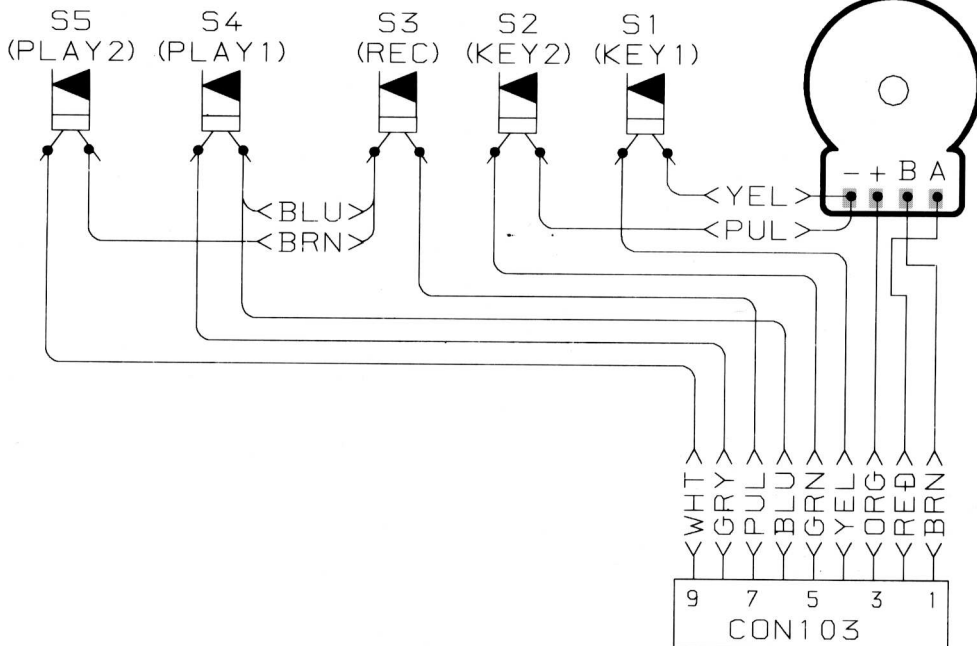

FROM [B] FRONT C.B.
CN701

A
B
C
D
E
F
G
H
I
J
K
L
M
N
O
P
Q
R
S
T
U

IC BLOCK DIAGRAM

IC, M62495AFP

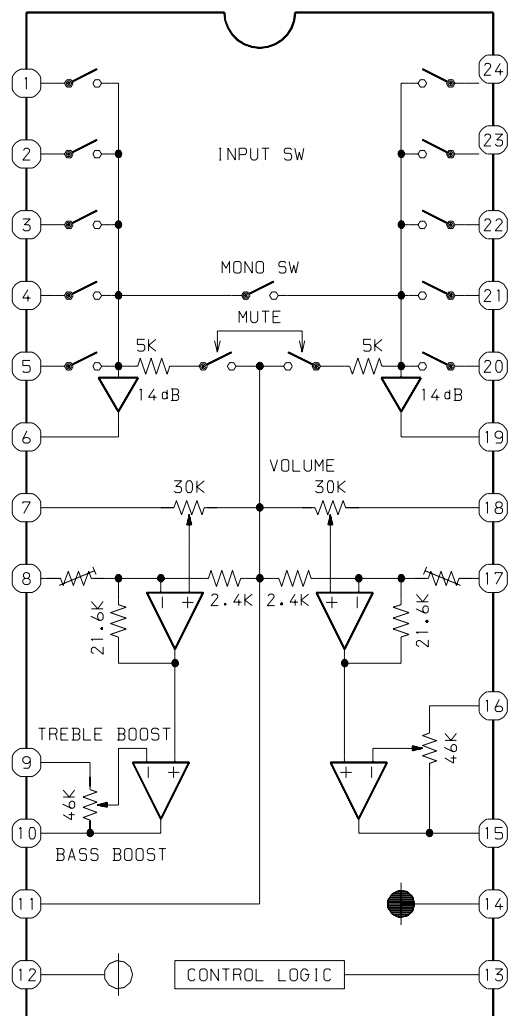

IC, LA1844L-A

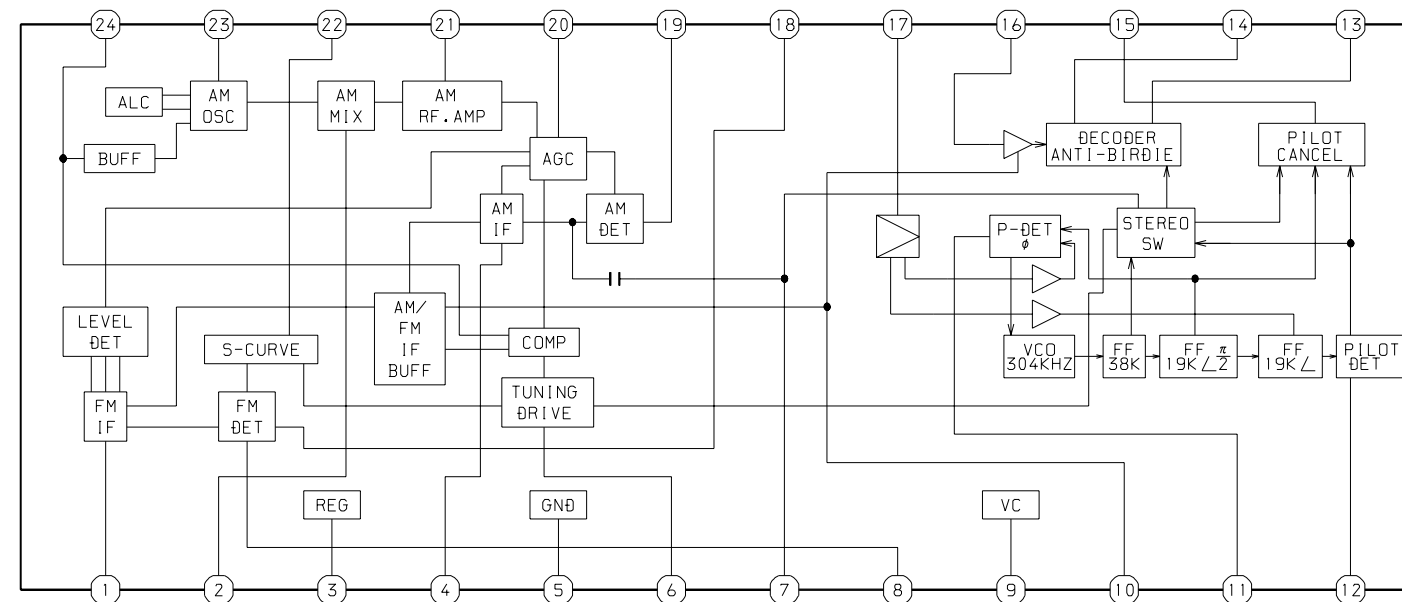

IC, LC72131D

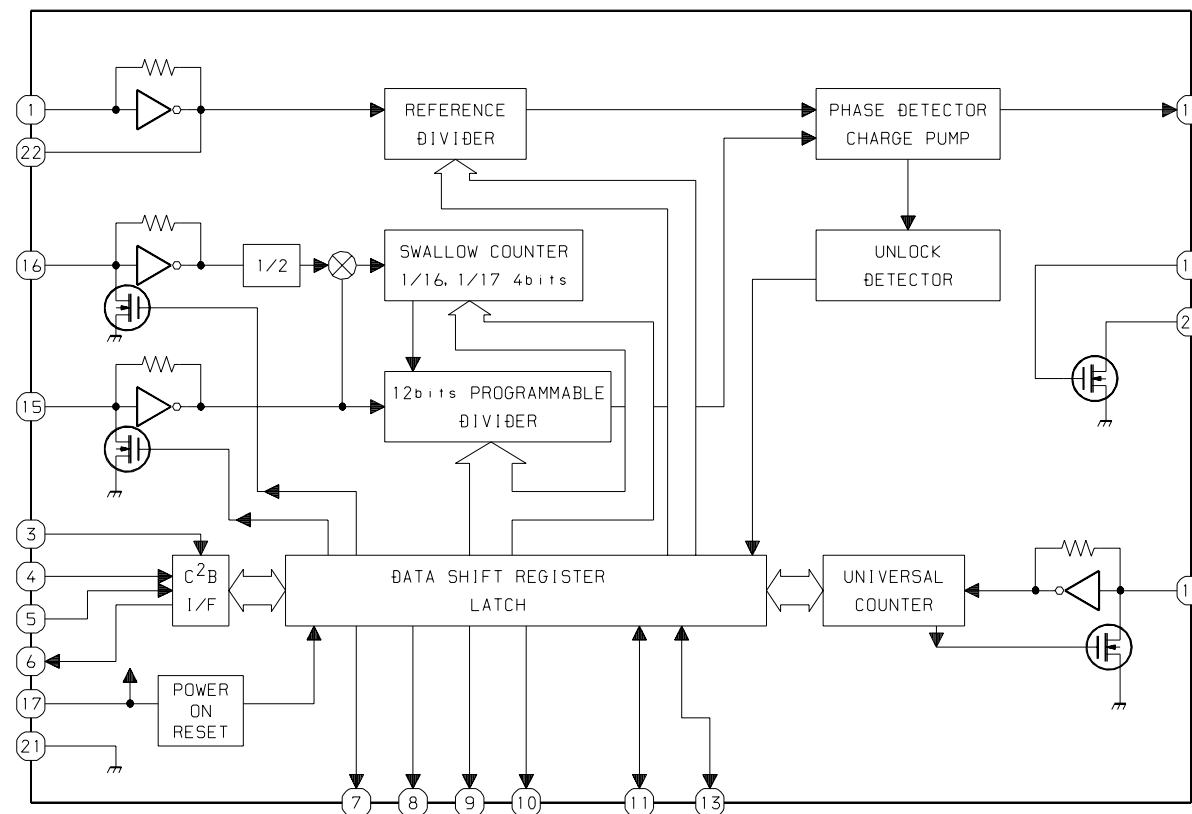

IC DESCRIPTION

IC, M38B57MCH-E236FP

Pin No.	Pin Name	I/O	Description
1	I-SIG	I	RDS signal level A/D input. (Not used)
2	I-HOLD	I	Hold voltage level A/D input.
3	I-SW (CD)	I	CD mecha SW A/D input.
4	I-DISH	I	CD turn-table position check A/D input.
5	I-KEY2	I	KEY2 A/D input.
6	I-KEY1	I	KEY1 A/D input.
7	I-RDS-DATA/ (O-DSP_DATA)	I/O	RDS data input / DSP IC data (V-CD) output. (Not used)
8	O-MOTOR	O	Deck motor supply ON/OFF output.
9	I-RMC	I	System remote control signal input. ("L"=ACTIVE)
10	RESET	I	System reset input. ("L"=RESET)
11	I-STEREO	I	Tuner stereo input. ("L"=STEREO)
12	O-DSC/O-PLL_DATA	O	Function IC control & PLL data output.
13	VSS	-	GND.
14,15	XIN, XOUT	I/O	4.19MHz system CLK input / output.
16	VCC	-	Power supply input.
17	O-PB1	O	Deck 1/2 switch output. ("L"=PLAYBACK DECK 1)
18	O-STBY	O	Standby LED ON/OFF output. ("L"=ON)
19	O-RMT	O	REC mute output. ("H"=MUTE)
20	O-BIAS	O	Record bias ON/OFF output. ("L"=ON)
21	O-TU_ON	O	Tuner supply ON/OFF output. ("H"=ON)
22	O-CD_ON	O	CD supply ON/OFF output. ("H"= ON)
23	O-C.SHIFT	O	MICON clock shift output. ("L"=SHIFT)
24	O-PLL-CLK	O	PLL IC CLK output.
25	I-TM_BASE	I	8 Hz time base input.
26	O-CLOSE	O	CD door close output.
27	O-CD-OPEN	O	CD door open output.
28	VEE	-	Power supply input for FL display.
29	O-STB(DSP)	O	DSP IC strobe output. (Not used)
30	K-SCAN	O	Initial key scan output.
31	O-PLL_CE	O	CD PLL IC chip enable output.
32	O-CD_LED	O	CD flash window LED output.
33~42	G10~G1	O	FL grid output (G10~G1).
43	P22	O	FL segment output (P22). (Not used)
44~58	P21~P7	O	FL segment output (P21~P7).
59	PHONO/P6	I/O	PHONO diode input / FL segment output (P6).
60	CASINO DEMO/P5	I/O	CASINO DEMO diode input (Not used) / FL segment output (P5).
61	NON-ECO/P4	I/O	ECO OFF diode input / FL segment output (P4).
62	I-TU3/P3	I/O	TU 3 diode input (Not used) / FL segment output (P3).
63	I-TU2/P2	I/O	TU 2 diode input (Not used) / FL segment output (P2).
64	I-TU1/P1	I/O	TU 1 diode input (Not used) / FL segment output (P1).

Pin No.	Pin Name	I/O	Description
65	O-DISH_R	O	CD turn-table reverse turn output.
66	O-DISH_F	O	CD turn-table forward turn output.
67	I-SUBQ	I	Sub code-Q data input.
68	O-CD_CE	O	CD DSP chip enable output.
69	I-WRQ	I	CD WRQ input.
70	O-CLK (CD)	O	CD control clock output .
71	O-DATA (CD)	O	CD control data output.
72	I-TUNE/IFC	I	Tuner SD input / IF count input.
73	AVSS	-	GND.
74	VREF	-	Reference voltage.
75	I-DRF	I	CD DRF input.
76	I-RDS_CLK	I	RDS clock input. (Not used)
77	I-LEVEL	I	Connected to GND through a resistor.
78	O-POWER	O	SYSTEM Power ON/OFF output. ("H"=ON)
79	I-RE_VOL	I	Rotary encoder A/D input.
80	I-TP_SW	I	Deck mecha SW A/D input.

ADJUSTMENT <TUNER / DECK>

< TUNER SECTION >

1. Clock frequency Check
Settings : • Test point : TP2 (CLK)
Method : Set to MW 1602kHz and check that the test point is 2052kHz \pm 0.045kHz.
2. MW VT Check
Settings : • Test point : TP1 (VT)
Method : Set to MW 1602kHz and check that the test point is less than 8.0V.
Then set to 531kHz and check that the test point is more than 0.6V.
3. FM VT Check
Settings : • Test point : TP1 (VT)
Method : Set to FM 87.5MHz, 108.0MHz and check that the test point is more than 0.5V (87.5MHz) and less than 8.0V (108.0MHz).
4. MW Tracking Adjustment
Settings : • Test point : TP8(Lch), TP9(Rch)
• Adjustment location :
L951 (1/3) 1000kHz
Method : Set to AM(MW) 999kHz and adjust L951 (1/3) to MAX.
5. FM Tracking Check
Settings : • Test point : TP8(Lch), TP9(Rch)
Method : Set to FM 98.0MHz and check that the test point is less than 13dB μ V.
6. MW IF Adjustment
Settings : • Test point : TP8(Lch), TP9(Rch)
• Adjustment location :
L802 450kHz
7. LW VT Adjustment
Settings : • Test point : TP1 (VT)
• Adjustment location : L942
Method : Set to LW 144kHz and adjust L942 so that the test point becomes 1.3V \pm 0.05V.
Then set to LW 290kHz and check that the test point is less than 8.0V.
8. LW Tracking Adjustment
Settings : • Test point : TP8 (Lch), TP9 (Rch)
• Adjustment location :
L941 144kHz
TC942 290kHz
Method : Set up TC942 to center before adjustment. The level at 144kHz is adjusted to MAX by L941. Then the level at 290kHz is adjusted to MAX by TC942.

< DECK SECTION >

9. Tape Speed Adjustment (DECK 1)
Settings : • Test tape : TTA-100
• Test point : TP8(Lch), TP9(Rch)
• Adjustment location : SFR701
Method : Play back the test tape and adjust SFR701 so that the frequency counter reads 3000Hz \pm 5Hz.
10. Head Azimuth Adjustment (DECK 1, DECK 2)
Settings : • Test tape : TTA-330
• Test point : TP8(Lch), TP9(Rch)
• Adjustment location : Head azimuth adjustment screw
Method : Play back (FWD) the 8kHz signal of the test tape and adjust screw so that the output becomes maximum.
Next, perform on REV PLAY mode.
11. PB Frequency Response Check (DECK 1, DECK 2)
Settings : • Test tape : TTA-330
• Test point : TP8(Lch), TP9(Rch)
Method : Play back the 315Hz and 8kHz signals of the test tape and check that the output ratio of the 8kHz signal with respect to that of the 315Hz signal is within 4dB.
12. PB Sensitivity Check (DECK 1, DECK 2)
Settings : • Test tape : TTA-200
• Test point : TP8(Lch), TP9(Rch)
Method : Play back the test tape and check that the output level of the test point is 110mV \pm 3.5dB.
13. REC/PB Frequency Response Check (DECK 1)
Settings : • Test tape : TTA-602
• Test point : TP8(Lch), TP9(Rch)
• Input signal : 1kHz / 8kHz (LINE IN)
Method : Apply a 1kHz signal and REC mode. Then adjust OSC attenuator so that the output level at the test points becomes -20VU. Record and play back the 1kHz and 8kHz signals and check that the output of the 8kHz signals is 0dB \pm 5dB with respect to that of the 1kHz signal.
14. REC/PB Sensitivity Check (DECK 1)
Settings : • Test tape : TTA-602
• Test point : TP8(Lch), TP9(Rch)
• Input signal : 1kHz (LINE IN)
Method : Apply a 1kHz signal and REC mode. Then adjust OSC attenuator so that the output level at TP8, TP9 becomes 0VU. Record and play back the 1kHz signals and check that the output is -2dB \pm 3.5dB.

< FRONT SECTION >

15. u-CON OSC Adjustment
Settings : • Test point : TP5(K-SCAN)
• Adjustment location : L101
Method : Insert AC plug with pressing of TUNER function key and POWER key. Adjust L101 so that the frequency across the test point is 58.350Hz \pm 0.02Hz.

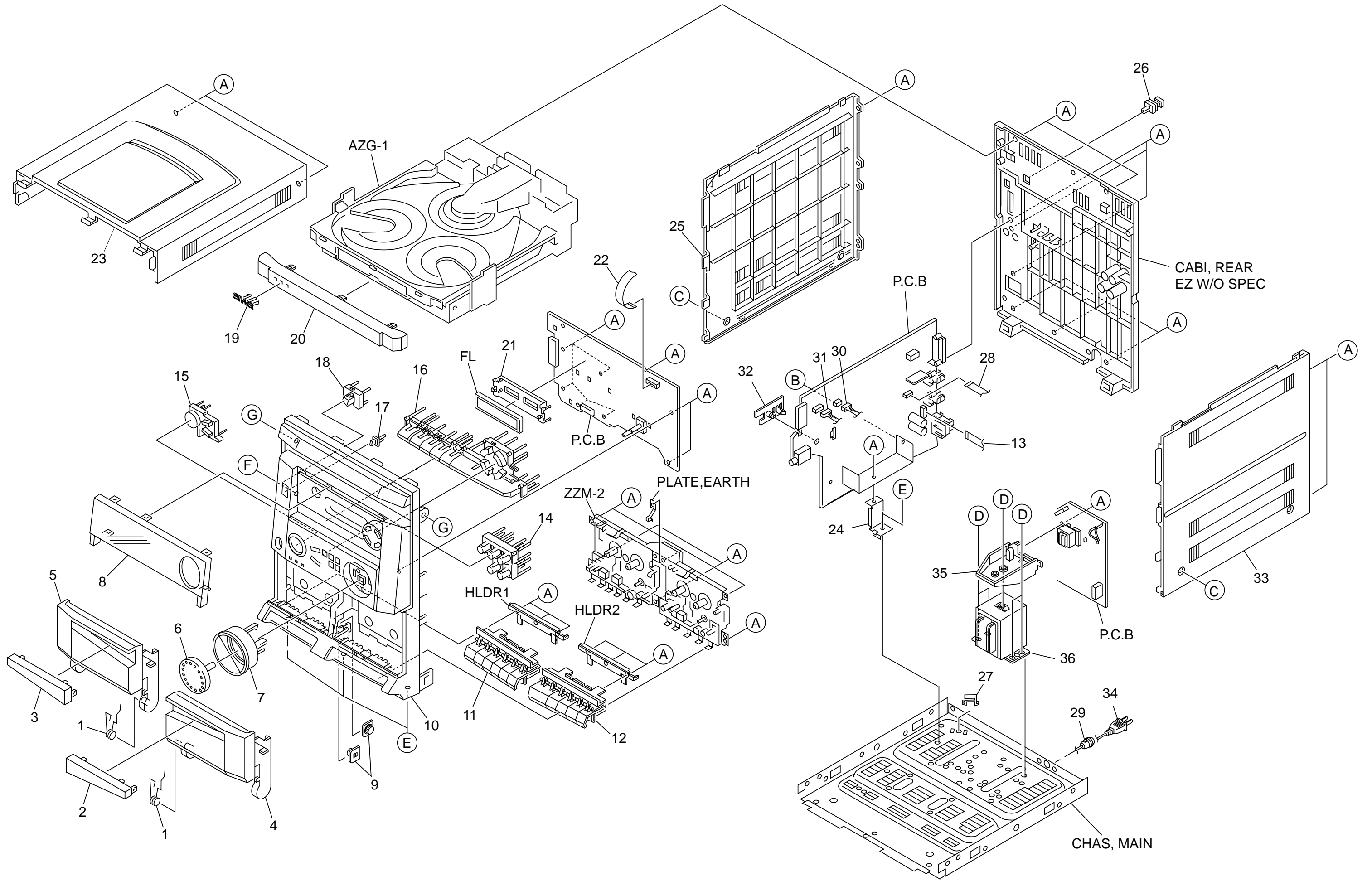

MECHANICAL PARTS LIST 1 / 1

REF. NO.	PART NO.	KANRI NO.	DESCRIPTION
1	82-NF7-218-010		SPR-T, CASS
2	8A-NFZ-007-110		WINDOW, CASS 2
3	8A-NFZ-006-110		WINDOW, CASS 1
4	8A-NFZ-004-110		BOX, CASS 2
5	8A-NFZ-003-110		BOX, CASS 1
6	8A-NFZ-011-010		KNOB, RTRY VOL
7	8A-NFZ-012-010		RING, VOL
8	8A-NFZ-058-010		WINDOW, DISP EZ DR4
9	86-NFZ-231-010		DMPR, 70
10	8A-NFZ-001-210		CABI, FR U
11	8A-NFZ-016-110		KEY, CASS 1
12	8A-NFZ-017-110		KEY, CASS 2P
13	85-NF5-628-010		F-CABLE 7P-2.5
14	8A-NFZ-010-010		KEY, OPE
15	8A-NFZ-013-210		KEY, CD
16	8A-NFZ-009-010		KEY, FUN
17	8A-NFA-018-010		REFLECTOR, ECO
18	8A-NFZ-008-010		KEY, POWER
19	87-CE3-023-010		BADGE, AIWA 30N SILV
20	8A-NFZ-002-010		PANEL, TRAY H
21	8A-NFA-208-010		GUIDE, FL 100-25 ANFA
22	88-913-221-110		FF-CABLE, 13P 1.25 220MM
23	8A-NFA-062-010		PANEL, TOP V-2
24	88-NF9-213-010		HLDLR, PWB MAIN
25	8A-NFA-063-010		PANEL, LEFT V-2
26	84-ZG1-245-210		CAP, OPTICAL
27	87-NF4-221-010		HLDLR, CABLE
28	88-906-251-110		FF-CABLE, 6P 1.25
29	87-085-185-010		BUSHING, AC CORD (E)
30	8A-NFA-633-010		CONN ASSY, 3P (PH)
31	8A-NFA-634-010		CONN ASSY, 8P RPB
32	8A-NFA-214-010		HLDLR, PWB M ANFA
33	8A-NFA-067-010		PANEL, RIGHT V-2 PL
⚠ 34	87-A80-157-010		AC CORD ASSY, E BLK CC
35	8A-NF9-211-010		HLDLR, PWB PT HI
⚠ 36	8A-NFA-608-010		PT, ANF-A EZ
A	87-067-703-010		TAPPING SCREW, BVT2+3-10
B	87-NF4-224-010		S-SCREW, IT3B+3-8 CU
C	87-067-641-010		UTT2+3-8 (W/O SLOT) BL
D	87-078-200-010		S-SCREW, ITC+4-8 R
E	87-067-688-010		BVTT+3-6
F	87-723-096-410		QT2+3-10W/O SLOT BL
G	87-721-097-410		QT2+3-12 GLD

COLOR NAME TABLE

Basic color symbol	Color	Basic color symbol	Color	Basic color symbol	Color
B	Black	C	Cream	D	Orange
G	Green	H	Gray	L	Blue
LT	Transparent Blue	N	Gold	P	Pink
R	Red	S	Silver	ST	Titan Silver
T	Brown	V	Violet	W	White
WT	Transparent White	Y	Yellow	YT	Transparent Yellow
LM	Metallic Blue	LL	Light Blue	GT	Transparent Green
LD	Dark Blue	DT	Transparent Orange	GM	Metallic Green
YM	Metallic Yellow	DM	Metallic Orange	PT	Transparent Pink

TAPE MECHANISM EXPLODED VIEW 1 / 1

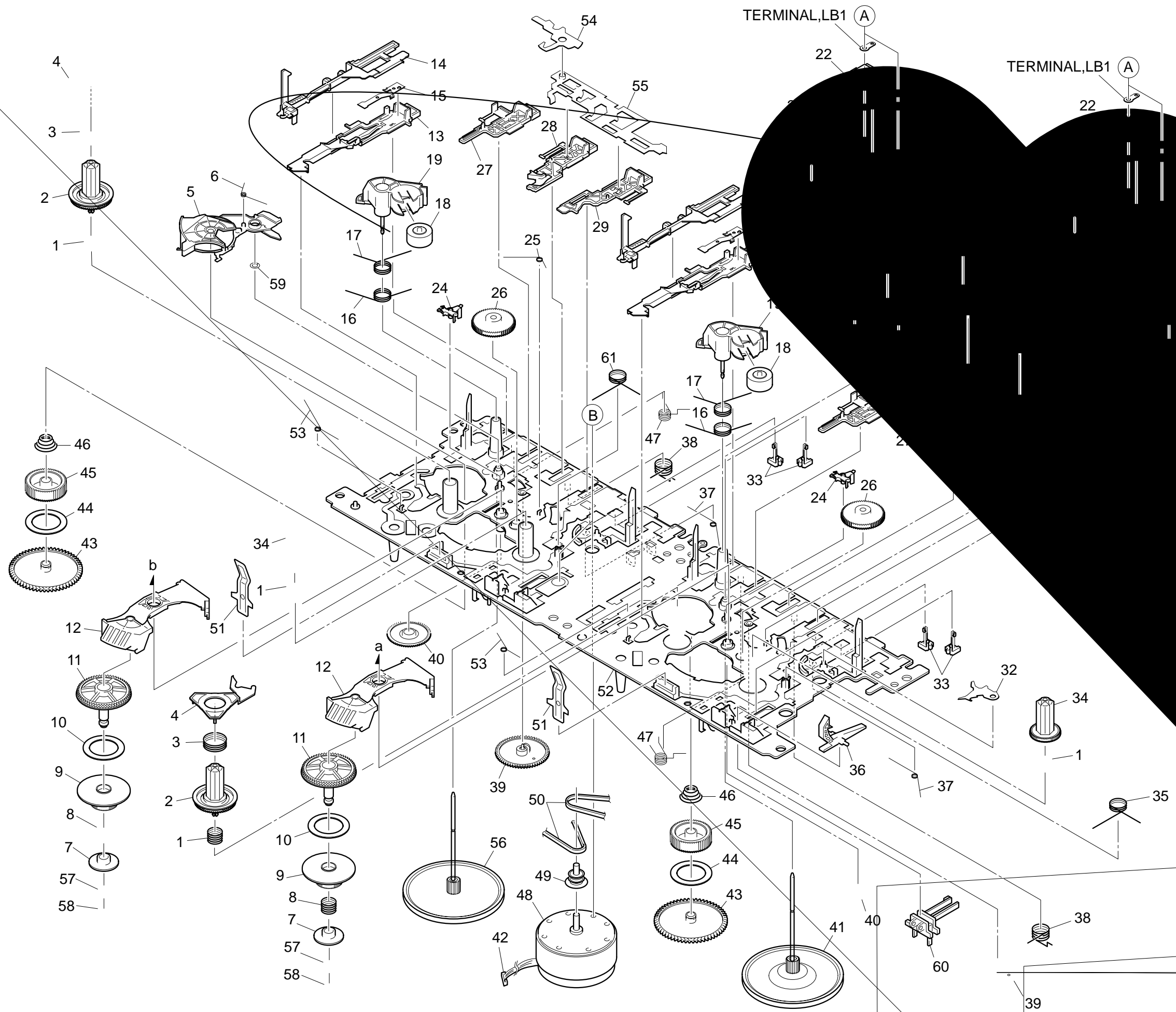

TAPE MECHANISM PARTS LIST 1 / 1

REF. NO.	PART NO.	KANRI NO.	DESCRIPTION	REF. NO.	PART NO.	KANRI NO.	DESCRIPTION
1	8Z-ZM1-254-310		SPR-C, REEL R	36	8Z-ZM1-220-110		LEVER, REC SENSOR
2	8Z-ZM1-225-110		GEAR, REEL R	37	8Z-ZM1-249-210		SPR-T, FR
3	8Z-ZM1-253-210		SPR-C, AUTO SENSOR	38	8Z-ZM1-242-310		SPR-T, FF/REW
4	8Z-ZM1-217-110		LEVER, AUTO SENSOR	39	8Z-ZM3-244-110		GEAR, CAM TD20
5	8Z-ZM1-212-210		LEVER, T-UP	40	8Z-ZM1-232-010		GEAR, IDL FF/REW
6	8Z-ZM1-245-310		SPR-T, AUTO	41	8Z-ZM3-256-010		FLY-WHL ASSY, M3 R
7	8Z-ZM1-236-010		CLR, SLIP FF/REW	42	8Z-ZM2-601-010		CONN ASSY, 9P ZZM-2
8	8Z-ZM1-252-110		SPR-C, FF/REW	43	8Z-ZM1-228-010		GEAR, SLIP T-UP B
9	8Z-ZM2-213-010		GEAR, SLIP FR A ZZM-2	44	8Z-ZM1-265-010		FELT, T-UP
10	8Z-ZM1-269-010		FELT, FF/REW 2	45	8Z-ZM1-227-010		GEAR, SLIP T-UP A
11	8Z-ZM1-238-110		GEAR, SLIP FF/REW B 2	46	8Z-ZM1-251-210		SPR-C, T-UP SLIP
12	8Z-ZM1-237-110		LEVER, FF/REW 2	47	8Z-ZM1-243-310		SPR-T, STOP/PAUSE
13	8Z-ZM1-209-510		LEVER, PAUSE	48	87-A91-532-010		MOT, MS15U2LW1A
14	8Z-ZM1-218-210		LEVER, E-LOCK H	49	8Z-ZM1-235-010		PULLEY, MOT
15	8Z-ZM1-256-010		SPR-P, PAUSE	50	8Z-ZM2-216-010		BELT, MAIN M
16	8Z-ZM1-244-110		SPR-T, T-UP	51	8Z-ZM1-260-010		SPR-P, CASSETTE
17	8Z-ZM1-247-310		SPR-T, PINCH	52	8Z-ZM2-201-510		CHAS ASSY, ZZM-2
18	8Z-ZM1-261-110		ROLLER ASSY, PINCH	53	8Z-ZM1-255-310		SPR-T, E-LOCK
19	8Z-ZM1-221-210		LEVER, PINCH	54	8Z-ZM2-219-010		LEVER, E-OPEN ZZM-2
20	8Z-ZM1-205-310		LEVER, PLAY	55	8Z-ZM1-214-310		LEVER, LOCK
21	8Z-ZM1-248-210		SPR-T, BRG	56	8Z-ZM1-290-010		FLY-WHL ASSY, ZZM-1
22	87-A90-403-110		HEAD, RPH MS15R	57	8Z-ZM1-257-110		SPR-C, F/R
23	84-ZM2-227-310		SPR-C, AZIMUTH	58	8Z-ZM1-275-010		W-L, 1.47-4-0.25
24	8Z-ZM1-216-110		LEVER, AUTO	59	87-B10-301-010		W-L, 1.63-3.2-0.5 SLIT
25	8Z-ZM1-246-110		SPR-T, AUTO 2	60	87-A91-494-010		SW, LEAF MSW17820
26	8Z-ZM2-214-110		GEAR, IDL REW ZZM-2	61	8Z-ZM1-241-010		SPR-T, PLAY
27	8Z-ZM2-212-010		LEVER, STOP ZZM-2	A	84-ZM2-242-010		S-SCREW, AZ1-2-6.4
28	8Z-ZM1-207-010		LEVER, FF	B	8Z-ZM2-220-110		V+2.6 ZZM-2
29	8Z-ZM1-206-010		LEVER, REW				
30	8Z-ZM1-210-010		LEVER, REC				
31	87-A90-404-010		HEAD, EH LE15B				
32	8Z-ZM2-218-010		LEVER, REC LOCK ZZM-2				
33	87-A91-492-010		SW, LEAF MSW18560				
34	8Z-ZM1-226-010		GEAR, REEL L				
35	8Z-ZM1-241-210		SPR-T, PLAY				

SPEAKER DISASSEMBLY INSTRUCTIONS

Type.1

Insert a flat-bladed screwdriver into the position indicated by the arrows and remove the panel. Remove the screws of each speaker unit and then remove the speaker units.

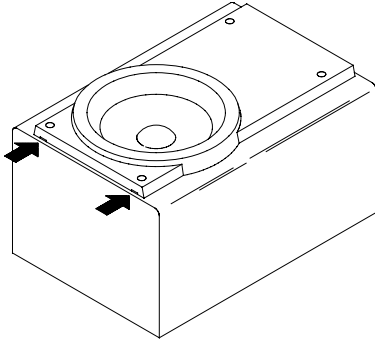

Type.2

Remove the grill frame and four pieces of rubber caps by pulling out with a flat-bladed screwdriver. Remove the screws from hole where installed rubber caps. Insert a flat-bladed screwdriver into the position indicated by the arrows and remove the panel. Remove the screws of each speaker unit and then remove the speaker units.

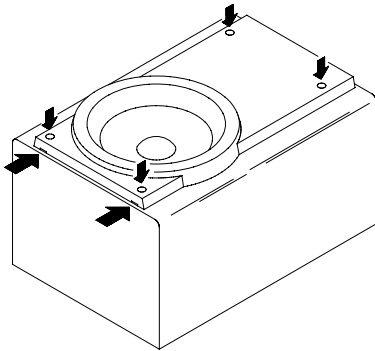

Type.3

Insert a flat-bladed screwdriver into the position indicated by the arrows and remove the panel. Turn the speaker unit to counter-clockwise direction while inserting a flat-bladed screwdriver into one of the hollows around speaker unit, and then remove the speaker unit. After replacing the speaker unit, install it turning to clockwise direction until "click" sound comes out.

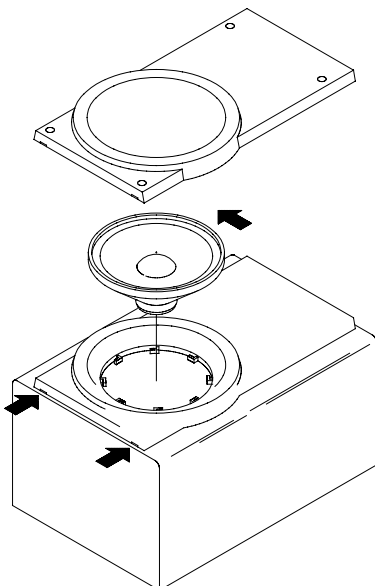

Type.4

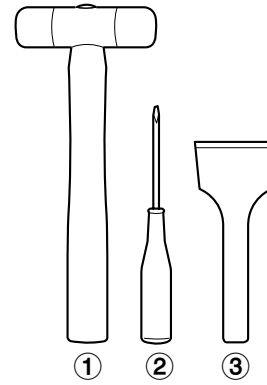

TOOLS

- ① Plastic head hammer
- ② (⊖) flat head screwdriver
- ③ Cut chisel

How to Remove the PANEL, FR

1. Insert the (⊖) flat head screwdriver tip into the gap between the PANEL, FR and the PANEL, SPKR. Tap the head of the (⊖) flat head screwdriver with the plastic hammer head, and create the clearance as shown in Fig-1.
2. Insert the cut chisel in the clearance, and tap the head of the cut chisel with plastic hammer as shown in Fig-2, to remove the PANEL, FR.
3. Place the speaker horizontally. Tap head of the cut chisel with plastic hammer as shown in Fig-3, and remove the PANEL, FR completely.

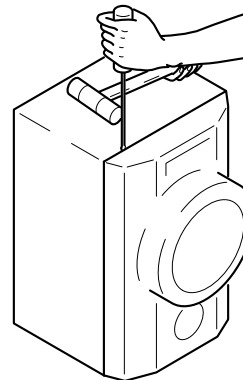

Fig-1

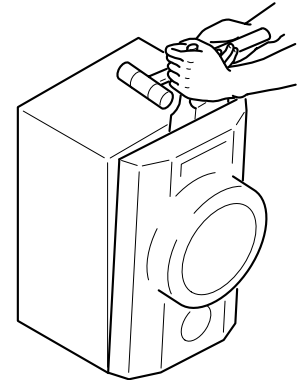

Fig-2

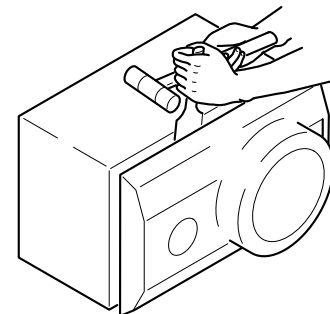

Fig-3

How to Attach the PANEL, FR

Attach the PANEL, FR to the PANEL, SPKR. Tap the four corners of the PANEL, FR with the plastic hammer to fit the PANEL, FR into the PANEL, SPKR completely.

SPEAKER PARTS LIST SX-NBL11(YSC9,YSC,YSL)

REF. NO.	PART NO.	KANRI NO.	DESCRIPTION
1	8A-NSB-001-010		PANEL, FR
2	8A-NSB-003-010		GRILLE, FRAME ASSY
3	8Z-NSL-603-010		SPKR, W 120<YSC9>
3	8A-NSL-606-010		SPKR, W120<YSC, YSL>
4	87-NS7-611-010		CORD, SPKR

ACCESSORIES / PACKAGE LIST

REF. NO.	PART NO.	KANRI NO.	DESCRIPTION
1	8A-NFZ-927-010		IB, EZ (9L) E-DR4
2	8Z-NF9-701-210		RC UNIT, ZAS02
3	87-A90-118-010		ANT, WIRE FM (Z)
4	87-006-225-010		AM LOOP ANT NC2

アイワ株式会社 〒110-8710 東京都台東区池之端1-2-11 ☎03(3827)3111 (代表)
AIWA CO.,LTD. 2-11, IKENOHATA 1-CHOME, TAITO-KU, TOKYO 110, JAPAN TEL:03 (3827) 3111