

*Most - Often - Needed*

1958

Volume 18

**RADIO**  
**DIAGRAMS**  
*and Servicing Information*

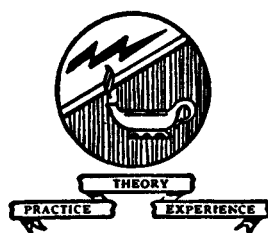

Compiled by  
**M. N. BEITMAN**

**SUPREME PUBLICATIONS**

## RADIO DIAGRAM MANUALS

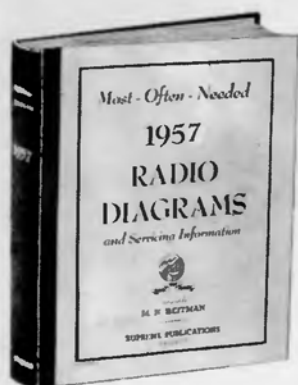

New 1957 VOLUME 17  
Price \$2.50

Repair quickly all new 1957 sets as well as older radios. This big volume contains clearly printed, large schematics, needed alignment data, replacement parts lists, voltage values, and information on stage gain, location of trimmers, and dial stringing, for all important new 1957 sets. Includes material on portables, clock radios, record changers, FM, and auto sets. A worthy companion to sixteen previous volumes used by over 143,000 shrewd radio servicemen. Large size: 8½ x 11 inches. Manual style binding. Postpaid, only ..... **\$250**

### RADIO DIAGRAMS FOR PREVIOUS YEARS

Speed up and simplify all radio repairs. Service radios faster, better, easier, save money and time, use these **SUPREME Most-Often-Needed** diagram manuals to get ahead. At the low cost (only \$2 for most volumes) you are assured of having for every job needed diagrams and other essential repair data on 4 out of 5 sets you will ever service. Clearly printed circuits, parts lists, alignment data, and helpful service hints are the facts you need. Average volume has 192 pages, large size 8½ x 11 inches. Manual style binding.

- |  |  |  |  |  |  |
|--|--|--|--|--|--|
| <input type="checkbox"/> 1956<br>Volume 16<br>\$2.50 | <input type="checkbox"/> 1955<br>Volume 15<br>\$2.00 | <input type="checkbox"/> 1954<br>Volume 14<br>\$2.50 | <input type="checkbox"/> 1953<br>Volume 13<br>\$2.50 | <input type="checkbox"/> 1952<br>Volume 12<br>\$2.50     | <input type="checkbox"/> 1951<br>Volume 11<br>\$2.50 |
| <input type="checkbox"/> 1950<br>Volume 10<br>\$2.50 | <input type="checkbox"/> 1949<br>Volume 9<br>\$2.50  | <input type="checkbox"/> 1948<br>Volume 8<br>\$2.00  | <input type="checkbox"/> 1947<br>Volume 7<br>\$2.00  | <input type="checkbox"/> 1946<br>Volume 6<br>\$2.00      |  |
| <input type="checkbox"/> 1942<br>Volume 5<br>\$2.00  | <input type="checkbox"/> 1941<br>Volume 4<br>\$2.00  | <input type="checkbox"/> 1940<br>Volume 3<br>\$2.00  | <input type="checkbox"/> 1939<br>Volume 2<br>\$2.00  | <input type="checkbox"/> 1926-1938<br>Volume 1<br>\$2.50 |  |

INDEX for all Radio and TV Manuals ..... 25¢

### Practical Radio & Electronics Course

Here is your complete home study course of 53 lessons designed to train any beginner to be an expert in radio and electronics. Covers every topic of radio, electronics, with lessons on test equipment, FM, TV, radio, etc. Giant 8½ x 11 inches, 3-in-1 volume, includes all lessons, instructor's notes, test questions. New edition. Only ..... **\$395**

ANSWER BOOK to the above course ..... 25¢

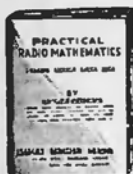

### RADIO MATHEMATICS

Explains arithmetic and simple algebra in connection with units, color code, meter scales, Ohm's law, alternating currents, ohmmeter testing, wattage rating, series and parallel connections, capacity, inductance, mixed circuits, vacuum tubes, curves, the decibel, etc., and has numerous examples. Only ..... **25¢**

1957-58 RCA Victor TV Manual... **\$150**



### RADIO SERVICING COURSE

Here is your practical radio course of 22 easy-to-follow lessons. Review fundamentals, learn new servicing tricks. Just like a \$200.00 correspondence course. Everything in radio servicing. With self-testing questions. New edition. Price only ..... **\$250**

## SUPREME TELEVISION MANUALS

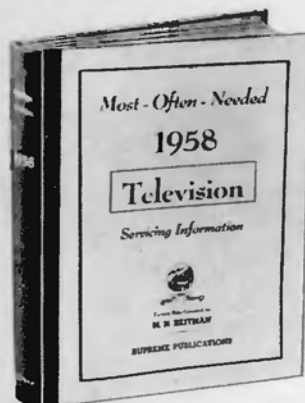

1958 TV Manual, TV-14

This new giant volume of 1958 television factory data will give you everything you need to repair and adjust all present-day TV sets. The **television series** manuals are amazing bargains and defy competition. The 1958 volume contains circuit explanations, 192 pages of alignment facts, test patterns, response curves, waveforms, voltage charts, hints, and dozens of mammoth double-page work-bench diagrams. Large size 8½ x 11 inches. Sturdy covers. Book binding opens flat. Amazing value. Price postpaid, only.... **\$3**

### EARLIER TV MANUALS FOR 1957 TO 1948

**Supreme TV** manuals cover all needed service material on every popular TV set of every important manufacturer. Here is helpful, practical, factory-prepared data that will really make TV servicing and adjustment easy for you. **Supreme** giant TV manuals have complete circuits, alignment facts, test patterns, response curves, service hints, recommended changes, voltage charts, waveforms, and many double-page diagram blueprints. Here is your TV service material to help you do more expert work quicker; and priced at only \$3. The **UHF Converters** manual at only \$1.50 has everything you need on UHF. **Radio** manuals described at left.

ADDITIONAL 1957 TV, Vol. TV-13, \$3.  
 EARLY 1957 TV Manual, TV-12, \$3.

- |  |   |   |   |
|--|---|---|---|
| <input type="checkbox"/> 1956 TV<br>Volume TV-11<br>\$3.00 | <input type="checkbox"/> 1955 TV<br>Additional, TV-10<br>\$3.00 | <input type="checkbox"/> 1955 TV<br>Early, Vol. TV-9<br>\$3.00  | <input type="checkbox"/> 1954 TV<br>Volume TV-8<br>\$3.00 |
| <input type="checkbox"/> 1953 TV<br>Volume TV-7<br>\$3.00  | <input type="checkbox"/> 1952 TV<br>Volume TV-6<br>\$3.00       | <input type="checkbox"/> 1951 TV<br>Volume TV-5<br>\$3.00       | <input type="checkbox"/> 1950 TV<br>Volume TV-4<br>\$3.00 |
| <input type="checkbox"/> 1949 TV<br>Volume TV-3<br>\$3.00  | <input type="checkbox"/> 1948 TV<br>Volume TV-2<br>\$3.00       | <input type="checkbox"/> UHF Converters<br>Volume UHF-1, \$1.50 |   |

### How to Modernize Radios



Cash in by improving and modernizing all out of date radio sets and cabinets. Practical job-sheets with schematics and photographs make this work easy. Size 8½ x 11 inches. Your price only..... **\$1**

### TELEVISION SERVICING COURSE

Let this new course teach you TV servicing. Amazing bargain, complete only \$3, full price for all lessons. Giant in size, mammoth in scope, topics just like a \$200.00 correspondence course. Lessons on picture faults, circuits, adjustments, short-cuts, UHF, alignment hints, antenna problems, trouble-shooting, test equipment, picture analysis. Special, only ..... **\$3**

### Simplified Radio Servicing by COMPARISON Method



Revolutionary different **COMPARISON** technique permits you to do expert work on all radio sets. Most repairs can be made without test equipment or with only a volt-ohmmeter. Many simple, point-to-point, cross-reference, circuit suggestions locate the faults instantly. Plan copyrighted. Covers every radio set — new and old models. This new servicing technique presented in handy manual form, size 8½ x 11 inches, 92 pages. Over 1,000 practical service hints. 26 large, trouble-shooting blueprints. Charts for circuit analysis. 114 tests using a 5c resistor. Developed by M. N. Beitman. New edition. Price only..... **\$150**

# Admiral

CHASSIS 5C4  
MODELS 263 • 264 • 265 • 268

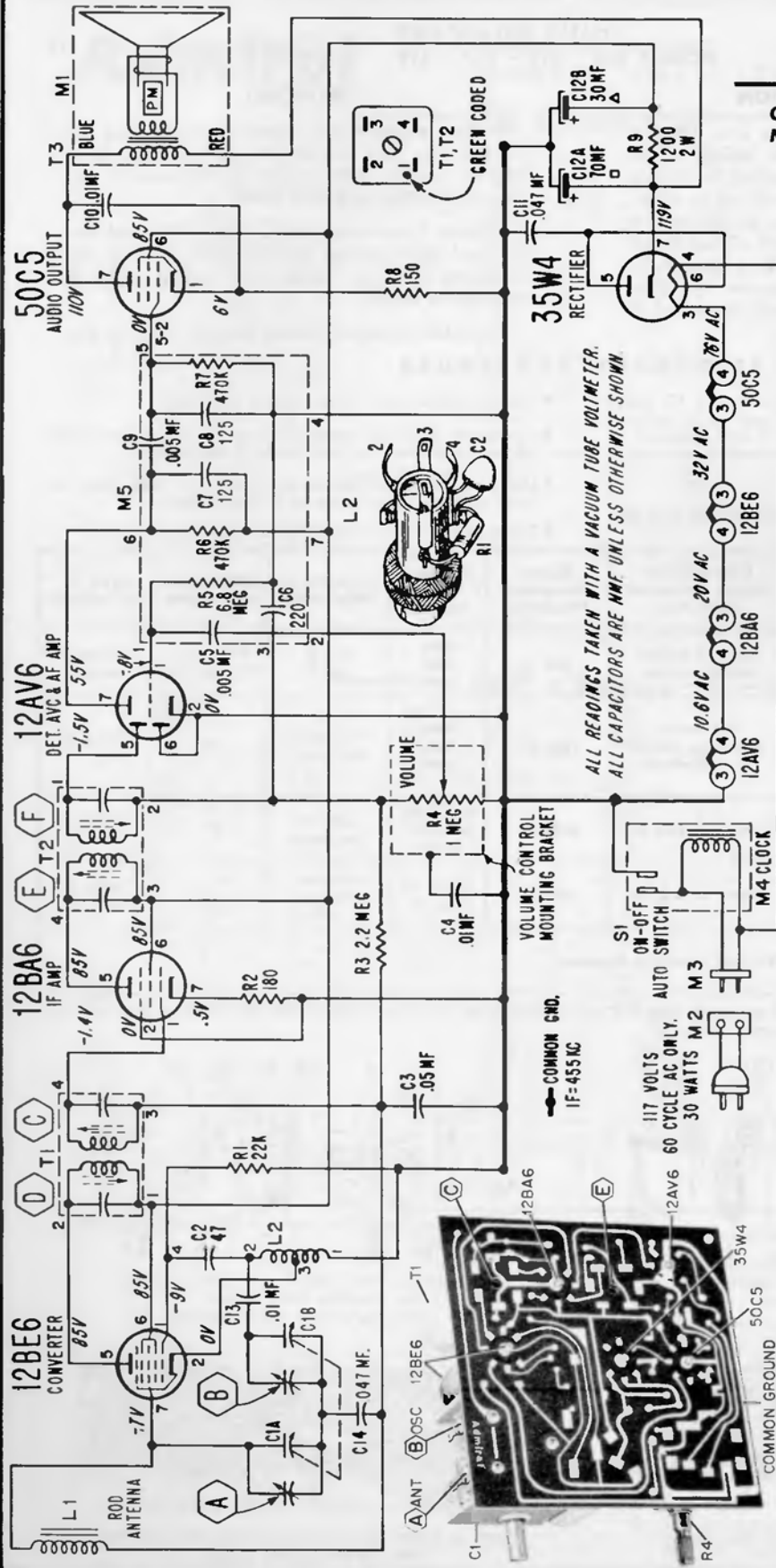

## ALIGNMENT PROCEDURE

STEP	CONNECTION OF SIGNAL GENERATOR	SIGNAL GENERATOR FREQUENCY	RECEIVER GANG SETTING	ADJUSTMENT
1	Through a .1 mf capacitor to stator, Antenna section of gang tuning capacitor	455 KC	Gang fully open	"F", "E", "D" and "C" for maximum output
2	Same as "STEP 1"	1620 KC	Gang fully open	"B" for maximum output
3	Radiated Signal. Loop of several turns of wire, or place generator lead close to receiver loop for adequate signal pickup.	1400 KC	Tune in on generator signal	"A" for maximum output

\*Adjustments "C" and "E" made from underside of chassis.

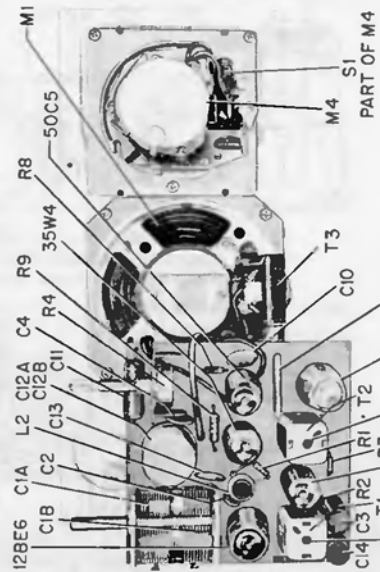

# Admiral

CHASSIS 200 and 4W2  
MODELS 202 • 215 • 217 • 218

(Continued on page 5)

## CHASSIS IDENTIFICATION

To determine whether the chassis is a 4W2 or 200 series, check the label pasted inside of the cabinet back cover. This label identifies the chassis by number. If the label has been torn out or otherwise removed, the chassis used can be determined by the clearance between the printed wiring board and the top of the cabinet. On the 4W2 chassis there is enough space for storing the power line cord above wiring board. On 200 chassis, line cord is stored below chassis.

## SERVICING

Replace resistors and capacitors by clipping out the defective part and leaving the pigtail leads as long as possible. Then, solder the replacement part onto the remaining pigtail leads.

Remove components such as coils, IF transformers, and tube sockets by alternately heating and loosening each pin. Brush away melted solder as each pin is heated.

Use a low wattage soldering iron, 35 watts or less.

## ALIGNMENT PROCEDURE

- When this set is aligned while operating on the AC power line, an isolation transformer should be used. If an isolation transformer is not available, connect a .1 mfd. capacitor in series with the signal generator low side to B minus (pin 7 of 1U5 tube).
- Set Volume control to maximum.
- DO NOT connect earth ground to common ground (see figs. 2 and 4).

- Connect output meter across speaker voice coil.
- Use lowest setting of signal generator capable of producing adequate indication on lowest scale of output meter.
- Use a non-metallic alignment tool with 3/32" wide blade to avoid splitting slotted cores on IF transformers.
- Repeat adjustments to insure good results.

Step	Dummy Antenna in Series with Signal Generator	Connection of Signal Generator (High Side)	Signal Generator Frequency	Receiver Gang Setting	Adjustment Description	Adjustment Designation	Type of Adjustment
1	.1 mfd. capacitor	Stator of antenna tuning capacitor	455 KC	Gang fully open	2nd IF 1st IF	"A", "B", "C" and "D"	Maximum output
2	Loop of several turns of wire, or place generator lead close to receiver for adequate signal pickup.	No actual connection (signal by radiation)	1620 KC	Gang fully open	Oscillator (on gang)	"E"	"Same as Step 1"
3	"Same as Step 2"	"Same as Step 2"	1400 KC	Tune in on generator signal	Antenna (on gang)	"F"	"Same as Step 1"
4 200 chassis only	"Same as Step 2"	"Same as Step 2"	600 KC	"Same as Step 3"	Antenna peaking coil	"G"	"Same as Step 1"
5 200 chassis only	Repeat Steps 3 and 4 until proper tracking is achieved.						

\*Adjustments "B" and "D" on chassis 4W2 are made from foil side. Adjustments "B" and "C" on chassis 200 are made from foil side. Remove chassis to make these IF transformer adjustments.

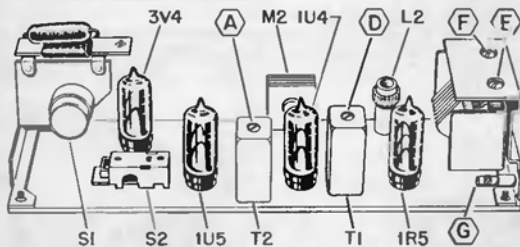

Figure 1. Top View of Chassis 200. Tube Locations and Alignment Points Shown.

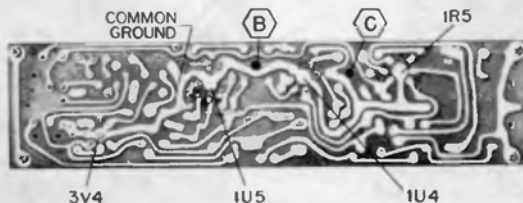

Figure 2. Bottom View of Chassis 200. Tube Locations and Alignment Points Shown.

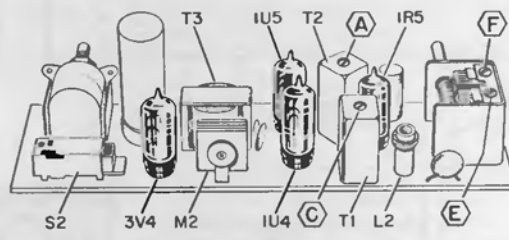

Figure 3. Top View of Chassis 4W2. Tube Locations and Alignment Points Shown.

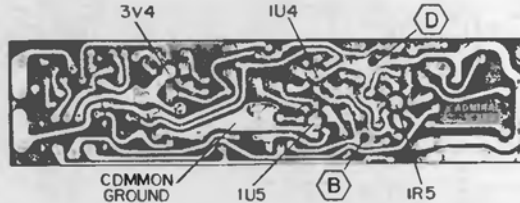

Figure 4. Bottom View of Chassis 4W2. Tube Locations and Alignment Points Shown.

# Admiral

CHASSIS 200 and 4W2  
MODELS 202 • 215 • 217 • 218

(Continued from page 4)

## 200 Chassis

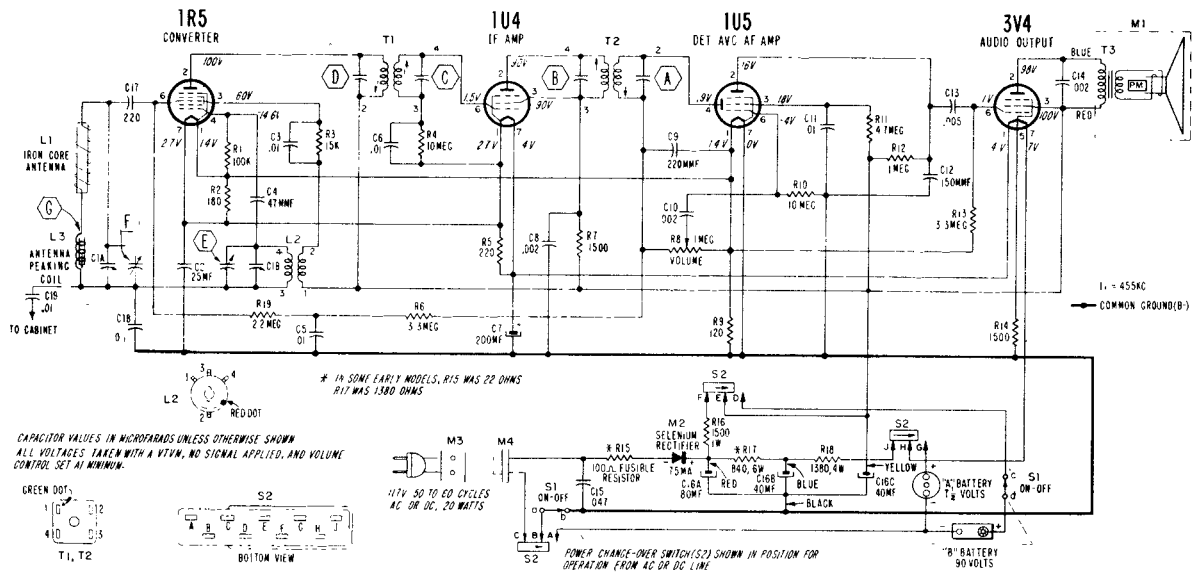

## 4W2 Chassis

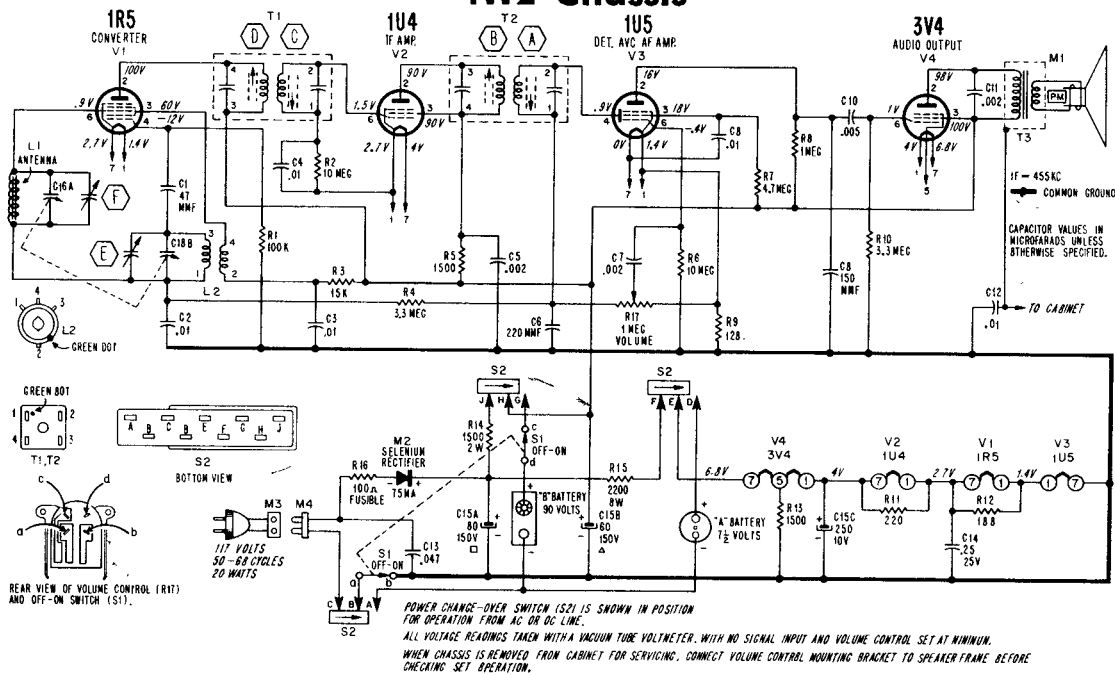

### REMOVING THE CHASSIS

1. Remove Tuning knob and Volume Control knob by working them forward and off their shafts.
2. Open cover on rear of cabinet.
3. On front of cabinet, loosen, but do not remove, two screws adjacent the tuning shaft.
4. Loosen, but do not remove, the hexnut that secures volume control shaft to cabinet front.
5. On chassis 4W2 only, remove Phillips screw that holds chassis to rear of speaker.

6. On 200 series chassis, remove the 1U4 vacuum tube. Remove the Phillips screw that connects through middle of selenium rectifier.
7. To prevent damage, hold the printed wiring board while removing the two screws and hex-nut located on cabinet front.
8. Gently lift the printed wiring board from within the case.
9. By straightening the four prongs which hold speaker frame to cabinet, the speaker may be removed.

# Admiral

Chassis 5B4 and 5D4, Continued on page 7.

## SERVICING

MODEL	COLOR	CHASSIS
242	Maroon	5B4
244	White & Pink	
245	Red & White	
248	Green & White	
275	Red & White	5D4
278	Green & White	
279	Gray & White	

Figure 2, refers to the foil side of the printed circuit board. It shows alignment points, tube locations, and location of the common ground line.

Figures 3 and 4, refer to the 5B4 and 5D4 chassis respectively.

Figures 3 and 4 show the location of all resistors, capacitors, coils and transformers.

To further simplify parts identification and location, schematic symbol numbers are printed adjacent to respective components on the printed circuit board.

### 5B4

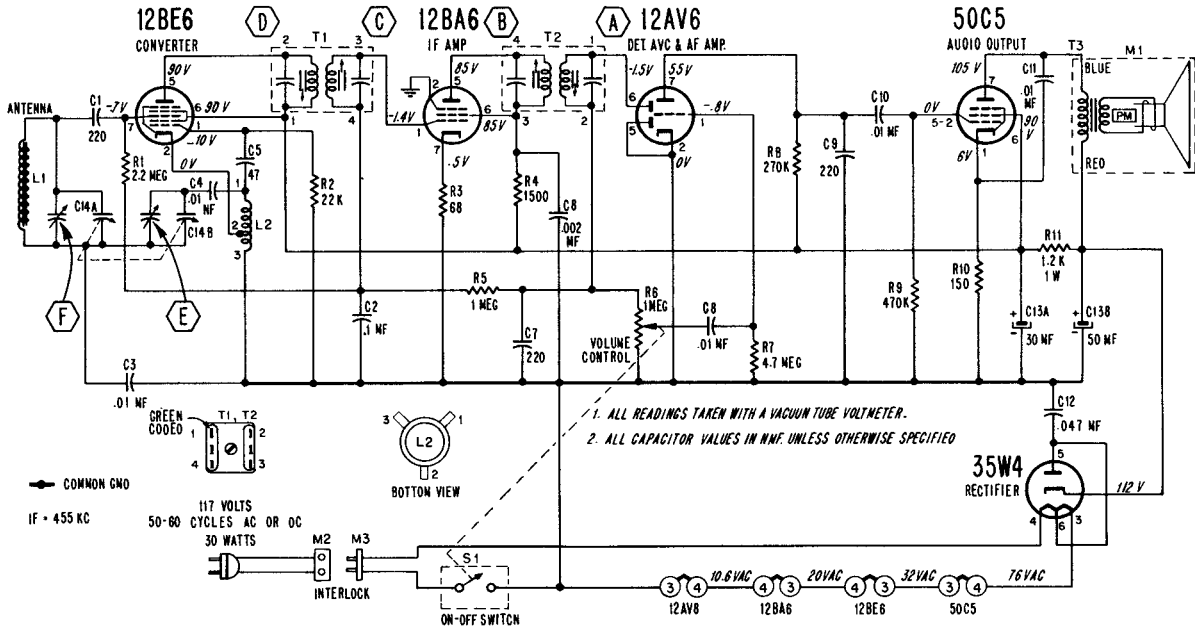

### 5D4

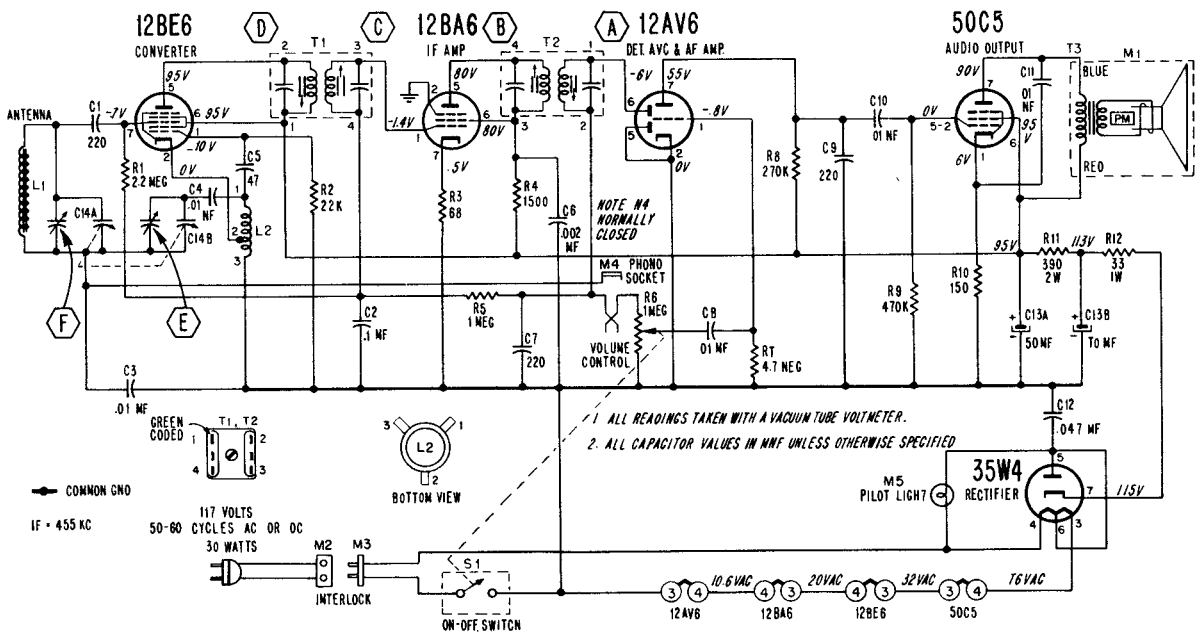

# Admiral

CHASSIS 5B4, 5D4  
 MODELS 5B4 (242 • 244 • 245 • 248) (Continued from page 6)  
 5D4 (275 • 278 • 279)

### REMOVING THE CHASSIS

1. Disconnect line cord and remove the two screws located near the front on cabinet bottom. See figure 1.
2. Loosen the two chassis retaining screws on the back of cabinet until they are held by only the last threads.
3. While steadying the cabinet, apply pressure to the loosened chassis screws with thumbs. Since the chassis is secured to the panel, this assembly will slide forward.
4. Remove the loosened chassis screws.
5. Remove chassis and panel assembly by grasping

### TO REMOVE CHASSIS FOR SERVICING TUBES

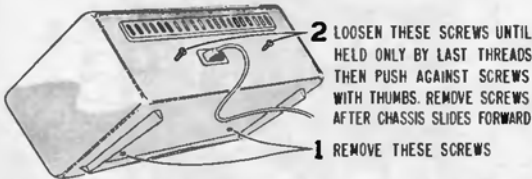

Figure 1. Rear View of Cabinet Showing Chassis Mounting Screws.

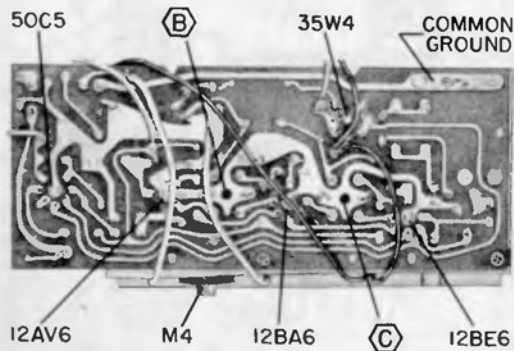

Figure 2. Bottom View of 5D4 Chassis Showing Alignment Points and Tube Locations. 5B4 chassis has same location for tubes and alignment points. Common ground is also the same.

the control knobs and pulling free from front of cabinet.

6. To replace, position chassis and panel assembly inside the cabinet and secure the panel and chassis assembly to the cabinet with the proper screws.

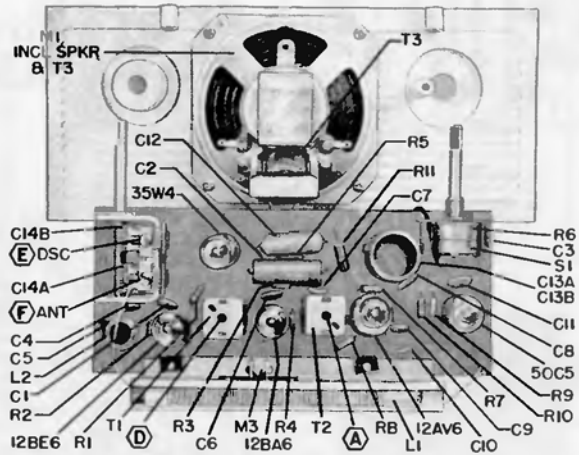

Figure 3. Top View of 5B4 Chassis Showing Location of Components and Alignment Points.

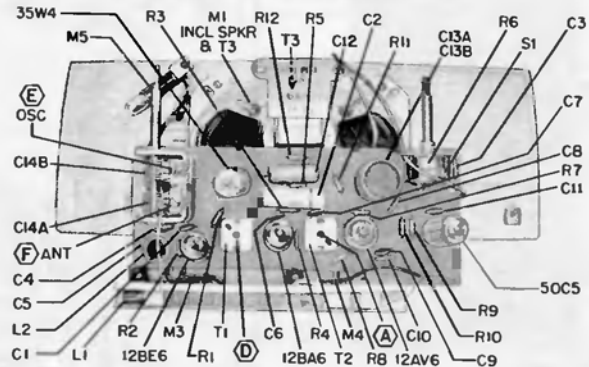

Figure 4. Top View of 5D4 Chassis Showing Location of Components and Alignment Points.

### ALIGNMENT PROCEDURE

- Use an isolation transformer if available; otherwise, connect a .1 mfd. capacitor in series with low side of signal generator and connect to common ground (see figure 2). Caution: Do not connect a ground wire to common ground.
- Set volume control full on.
- Connect output meter across speaker voice coil.
- Use lowest setting of signal generator capable of producing adequate indication on lowest scale of output meter.
- Use a non-metallic alignment tool with a blade 3/32" wide for aligning IF transformers.
- Repeat adjustments to insure good results.

STEP	CONNECTION OF SIGNAL GENERATOR	SIGNAL GENERATOR FREQUENCY	RECEIVER GANG SETTING	ADJUSTMENT
1	Through a .1 mf capacitor to stator, Antenna section of gang tuning capacitor	455 KC	Gang fully open	"A", "B", "C" and "D" for maximum output
2	Same as "STEP 1"	1620 KC	Gang fully open	"E" for maximum output
3	Radiated Signal. Loop of several turns of wire, or place generator lead close to receiver loop for adequate signal pickup.	1400 KC	Tune in on generator signal	"F" for maximum output

\*Adjustments "B" and "C" made from underside of chassis; see figure 2.

# Admiral

CHASSIS 4P2

MODELS 4P21 • 4P22 • 4P24 • 4P28

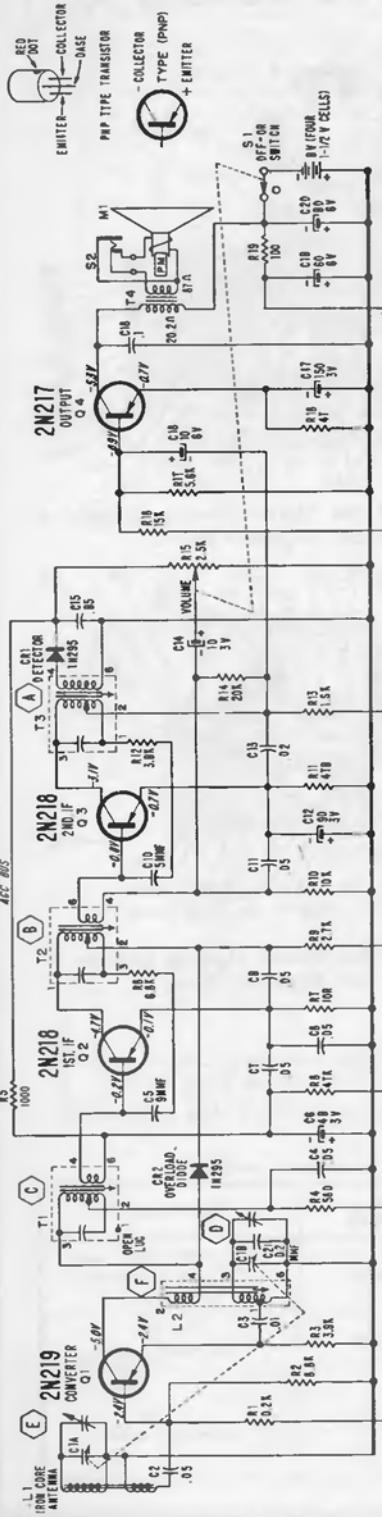

TOTAL CURRENT DRAIN WITH NO SIGNAL, A  
VOLUME CONTROL AT MINIMUM, 170 MA

2N219 CONV.

IF - 455 KC

I.F. 455 KC.

## Admiral

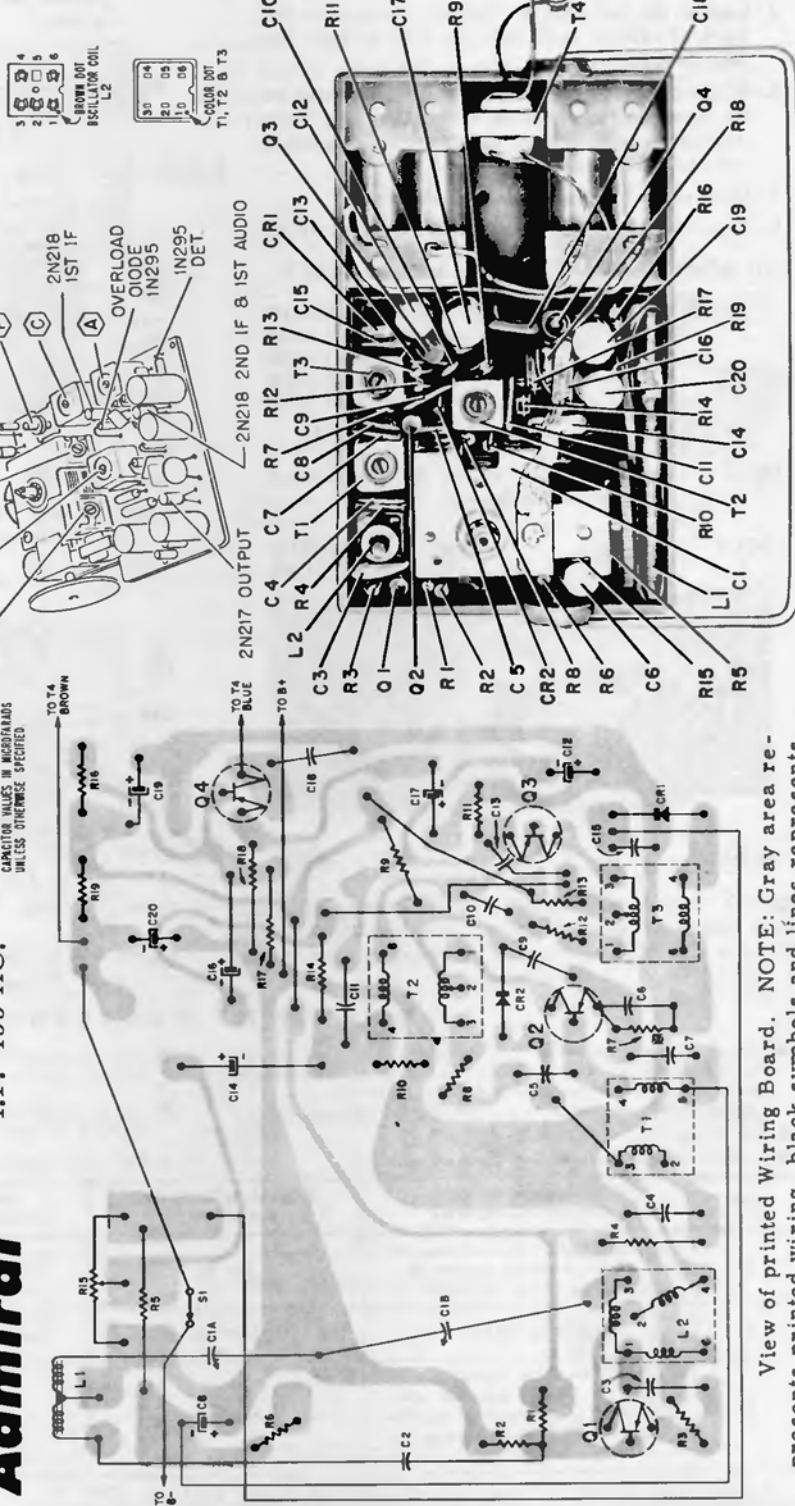

Top View of Chassis Showing Parts Locations

View of printed Wiring Board. NOTE: Gray area represents printed wiring, black symbols and lines represents components, wiring and connections on opposite side.



MOST-OFTEN-NEEDED 1958 RADIO SERVICING INFORMATION

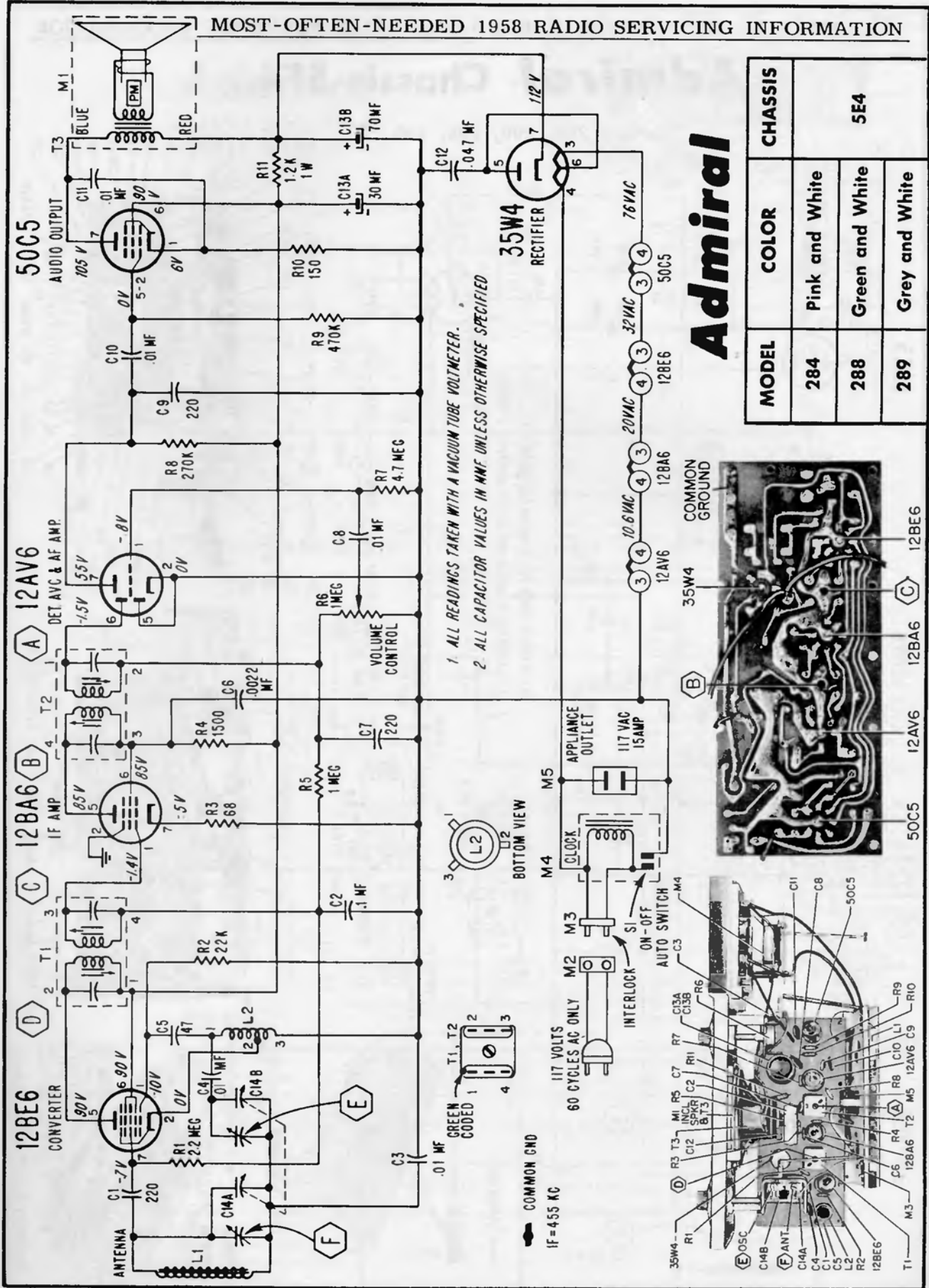

**Admiral**

MODEL	COLOR	CHASSIS
284	Pink and White	5E4
288	Green and White	
289	Grey and White	

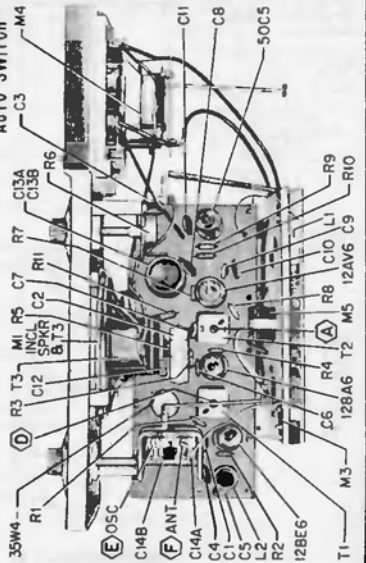
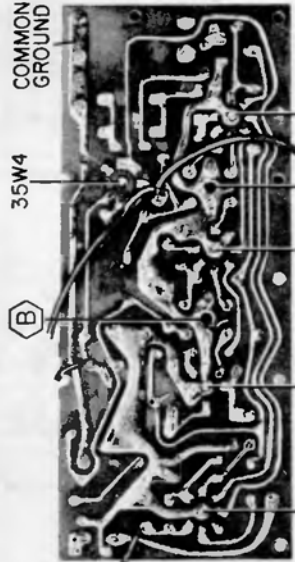

# Admiral Chassis 5F4

Models 292, 296, 298, 299

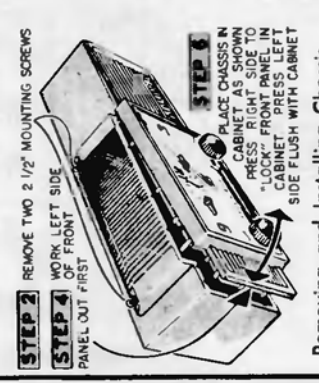
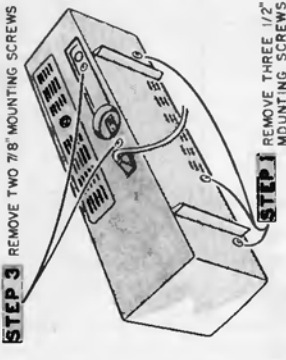
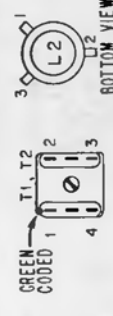
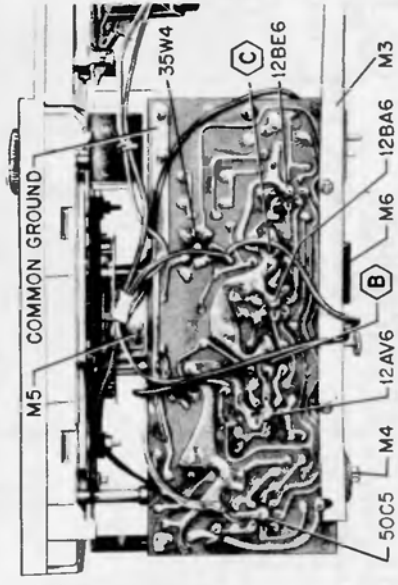
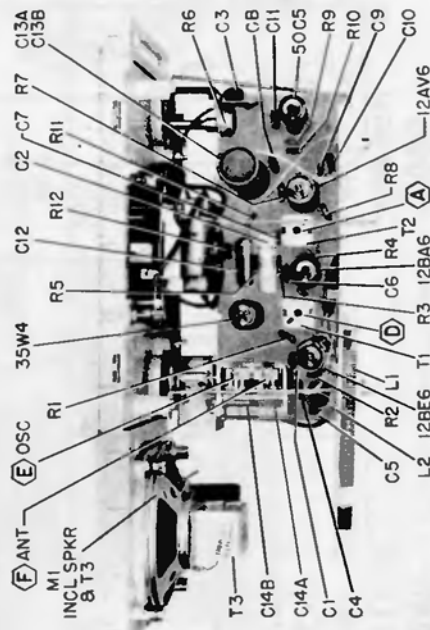
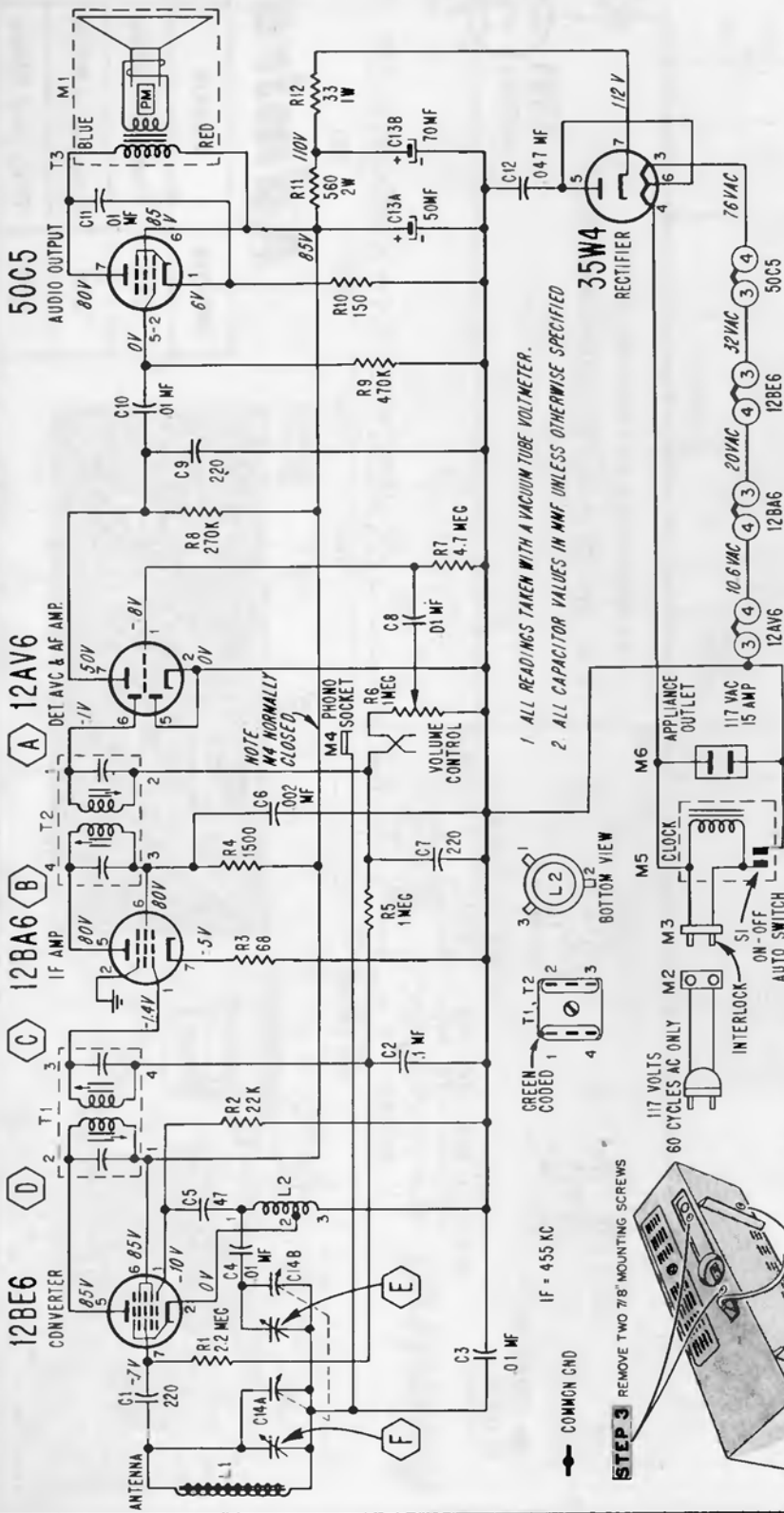

**STEP 2** REMOVE TWO 2 1/2" MOUNTING SCREWS

**STEP 4** WORK LEFT SIDE PANEL OUT FIRST

**STEP 5** PLACE CHASSIS IN CABINET AS SHOWN "PRESS RIGHT SIDE TO LOCK" PROTECT IN CABINET FROM LEFT SIDE PLUSH WITH CABINET

Removing and Installing Chassis.

# Admiral

CHASSIS 5RP4, 5RP4A  
MODELS 5RP41, 5RP42

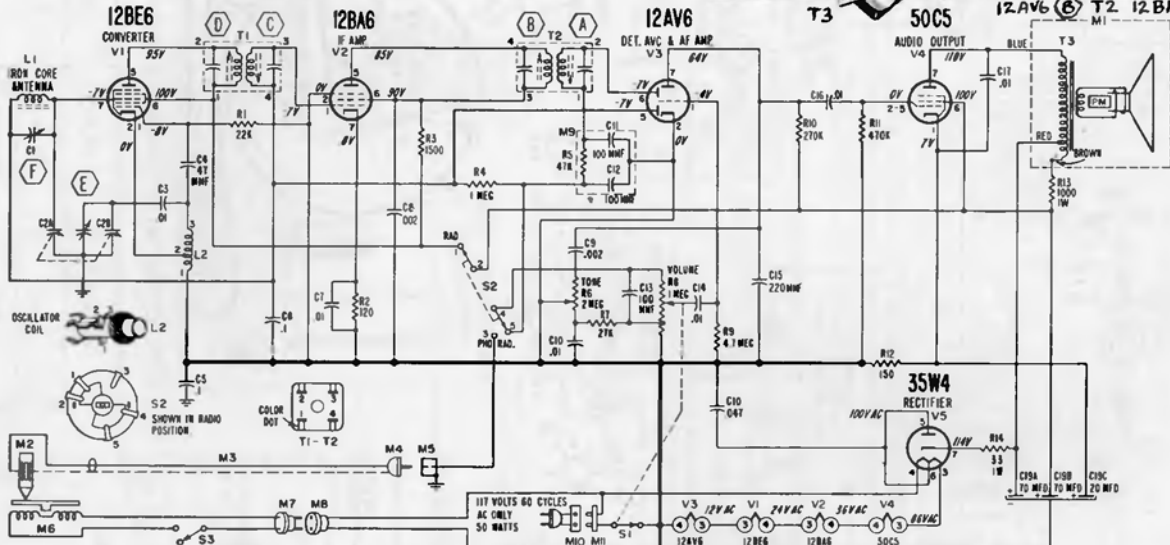
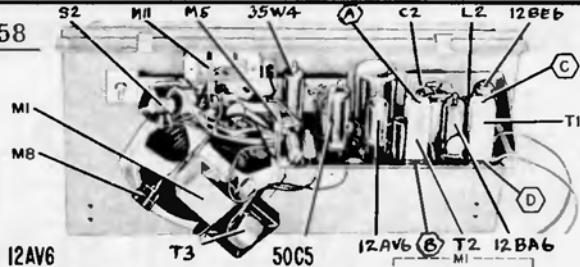

## 5RP4A

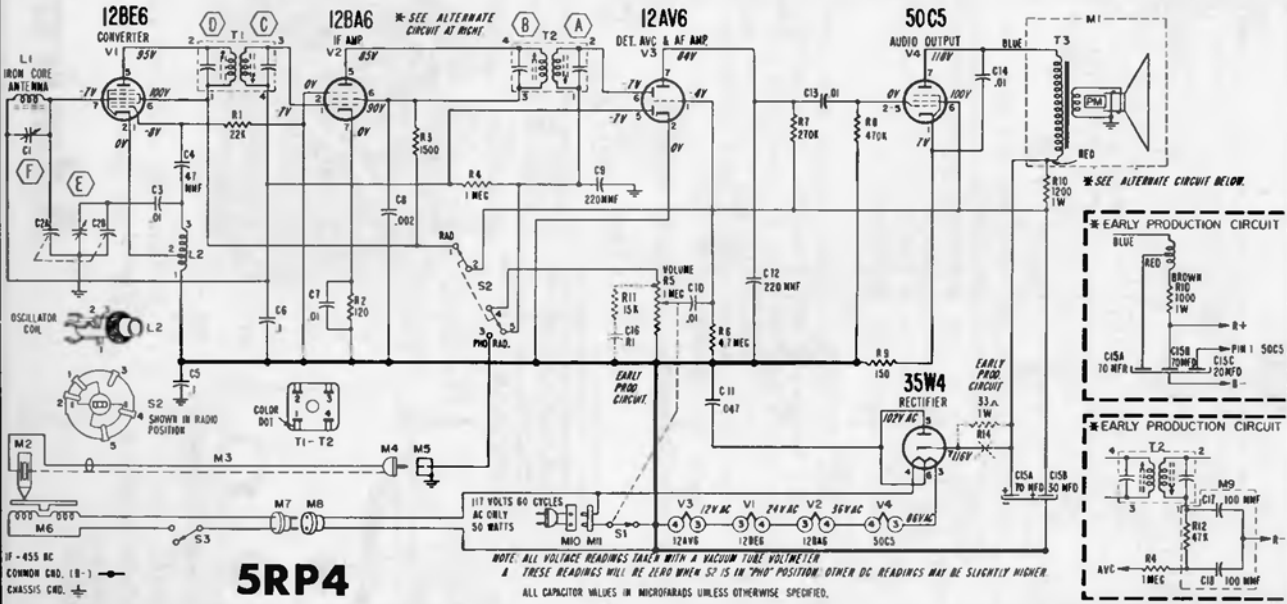

## 5RP4

Step	Connection Of Signal Generator	Signal Generator Frequency	Receiver Gang Setting	Adjustment
1	Through a .1 mf capacitor to pin 7 of the 12BE6 (Converter) tube.	455 KC	Gang fully open	"A", "B", "C" and "D" for maximum output
2	Same as "Step 1"	1620 KC	Gang fully open	"E" for maximum output
3	Radiated Signal. Place signal generator lead near enough antenna for adequate signal pickup.	1400 KC	1400 KC	**"F" for maximum output

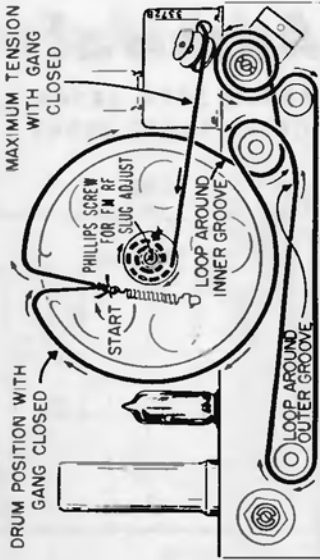
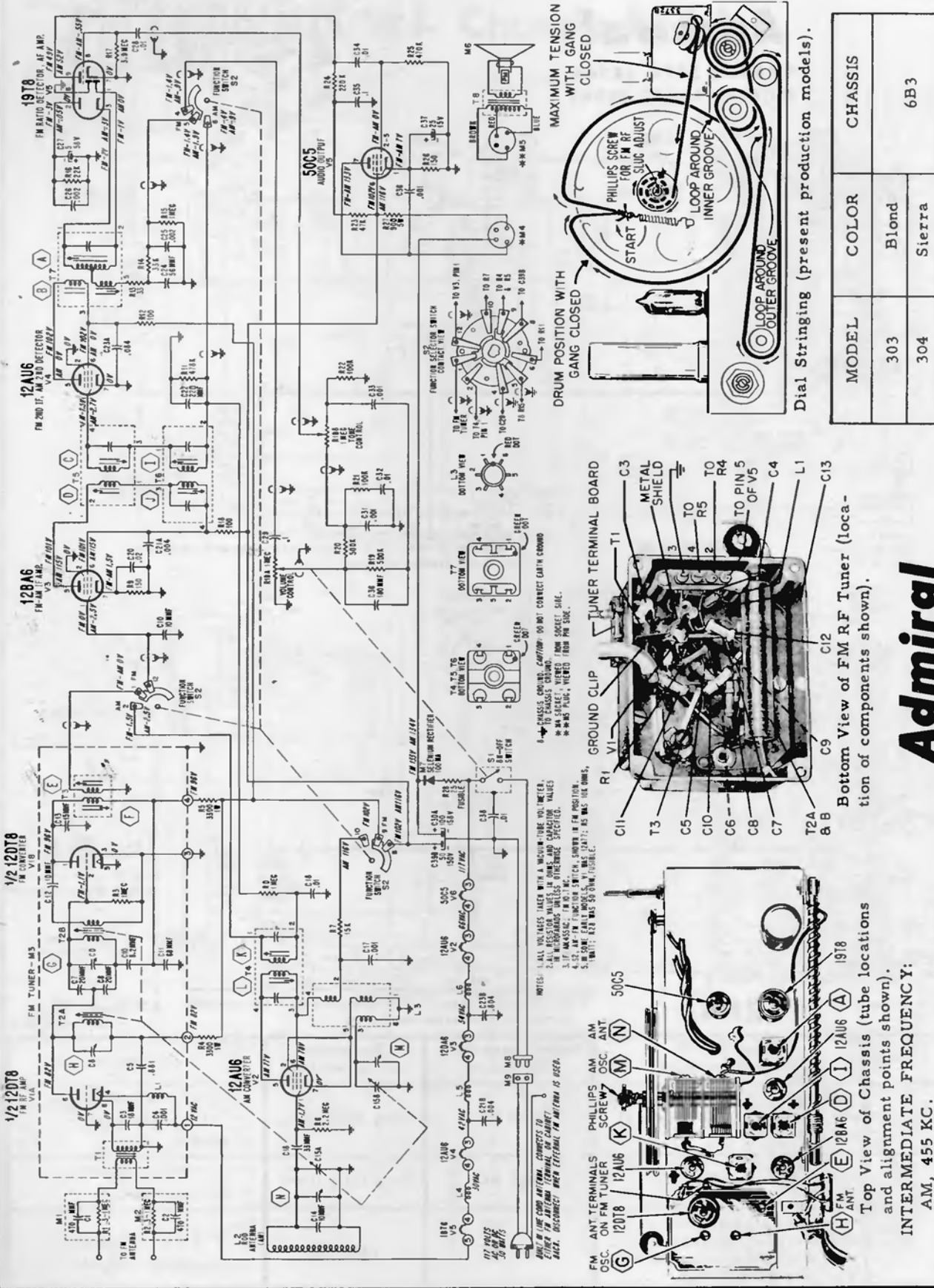

MODEL	COLOR	CHASSIS
303	Blond	6B3
304	Sierra	

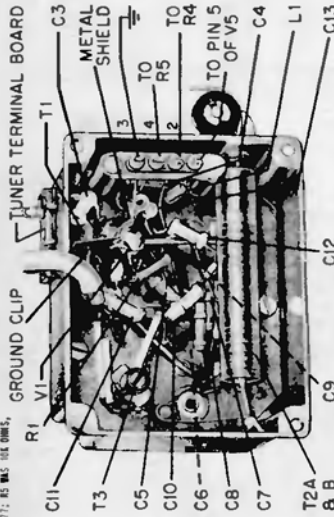

Bottom View of FM R.F. Tuner (10ca-tion of components shown).

**Admiral**

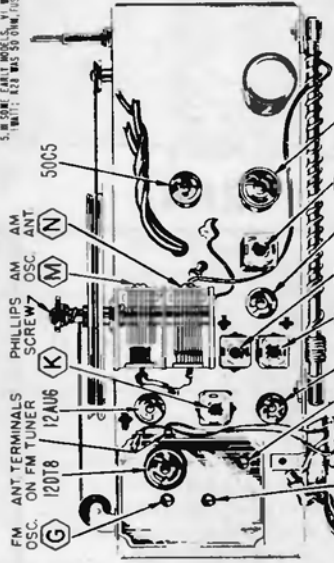

Top View of Chassis (tube locations and alignment points shown).

INTERMEDIATE FREQUENCY:  
AM, 455 KC.  
FM, 10.7 MC.

# Admiral 6R2B

## HI-FI CONSOLE PHONOGRAPH

MODEL	COLOR	CHASSIS	CHANGER
382	Mahogany	6R2B	RC637-2
383	Blonde		
384	Sierra		

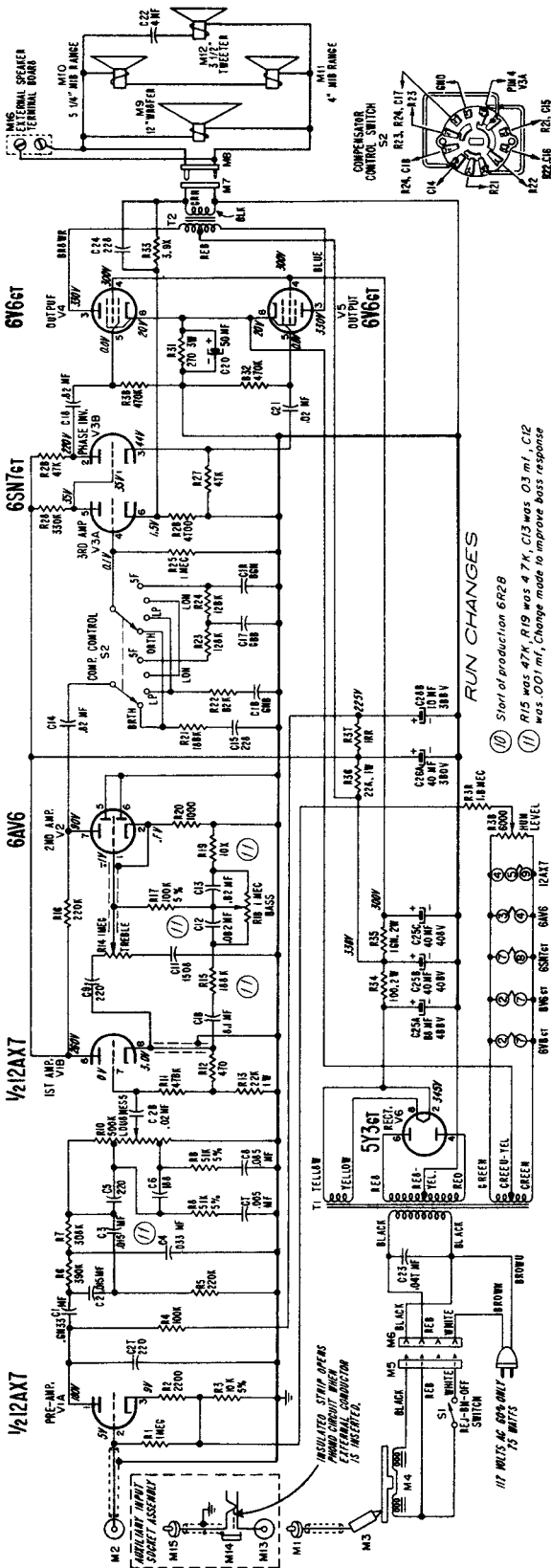

### TROUBLE SHOOTING HINTS

If the phonograph sounds weak or distorted, examine the needles for wear. A worn needle will cause excessive needle scratch and a harshness of treble tones. Test the tubes by substitution and then, if possible, try a new cartridge. Check voltage at tube pins against voltage readings shown on schematic.

**SERVICE NOTE:** The **Rej-On-Off** pointer (S1) on the record changer is used to turn both amplifier and record changer motor on and off. To turn the amplifier on with the record changer disconnected, a short, temporary jumper wire must be connected between the white and red leads on socket "M6". See schematic.

Amplifier voltage readings may also be taken by connecting the record changer motor plug (M5) to the socket (M6) on the chassis. Unclamp the **Tone Arm** from the tone arm rest and slide the **Rej-On-Off** pointer to the "ON" position. Set **Loudness** control for minimum and **Bass** and **Treble** controls to center rotation. Set **Compensation** control to "LON". Do not play a record while taking readings.

### HUM LEVEL ADJUSTMENT

The **Hum Level** control (R39 on schematic) can be set to eliminate any stray 60 cycle hum appearing in the amplifier output. Make the **Hum Level** adjustment as follows:

1. Turn set on by sliding **Rej-On-Off** pointer to "ON". Set **Compensation** control to "LON"; **Bass**, **Treble** and **Loudness** controls to "MAX" (fully clockwise).
2. Touch record changer centerpost. If hum level of amplifier output increases, reverse line cord in wall outlet. Touch centerpost again. Leave line cord plug in position that gives least amount of hum when centerpost is touched.
3. Find **Hum Level** control shaft which extends from rear of chassis (see figure 1). Vary control for minimum hum in output. (Setting R39 for minimum hum feeds to control grid of V1A an out-of-phase 60 cycle voltage of an amplitude sufficient to cancel out any stray 60 cycle hum picked up by amplifier.)

### VOLTAGE DATA

Voltage readings made in reference to chassis ground.

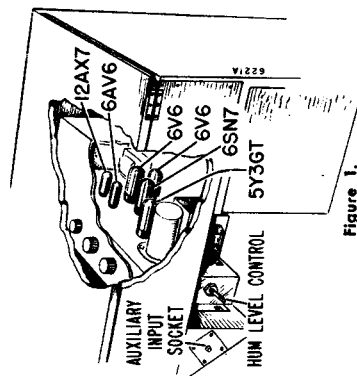

Figure 1.

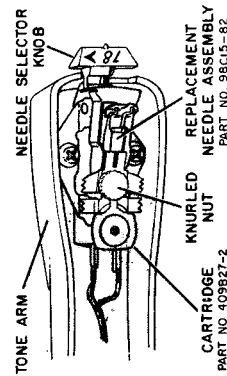
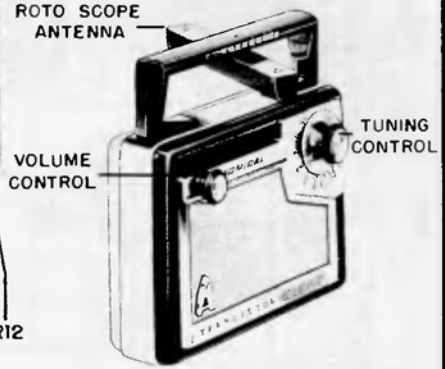
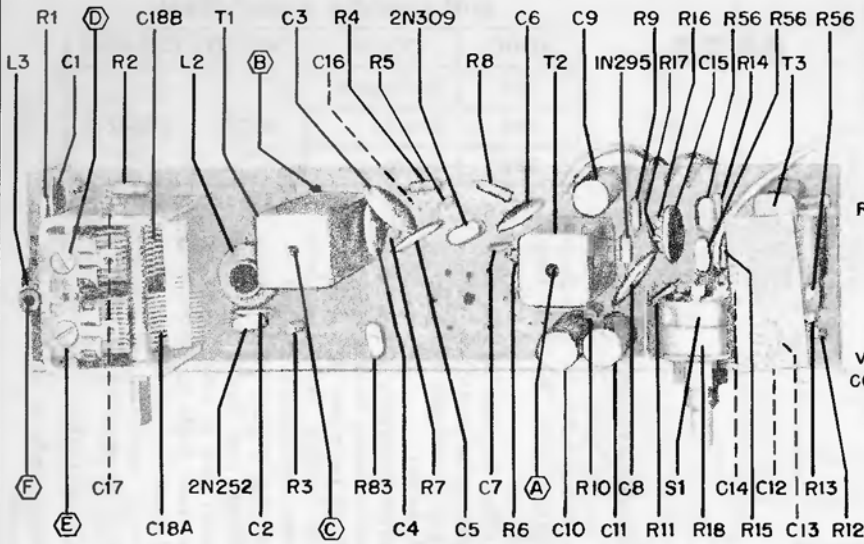

Figure 2.

# Admiral 6S2 CHASSIS

Models 221, 227, 228



INTERMEDIATE FREQUENCY: 455 KC.

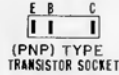
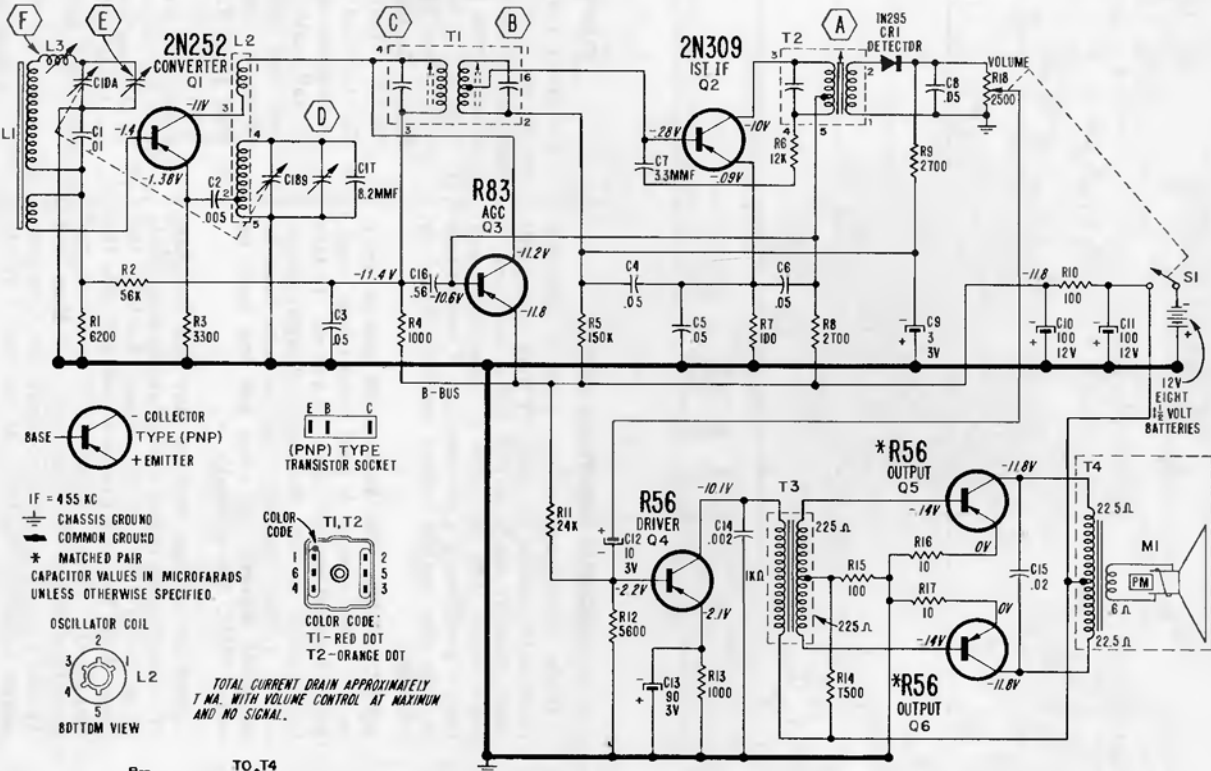

IF = 455 KC  
 CHASSIS GROUND  
 COMMON GROUND  
 \* MATCHED PAIR  
 CAPACITOR VALUES IN MICROFARADS  
 UNLESS OTHERWISE SPECIFIED.

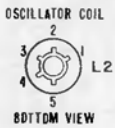
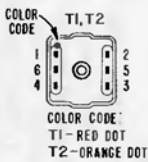

TOTAL CURRENT DRAIN APPROXIMATELY  
 7 MA. WITH VOLUME CONTROL AT MAXIMUM  
 AND NO SIGNAL.

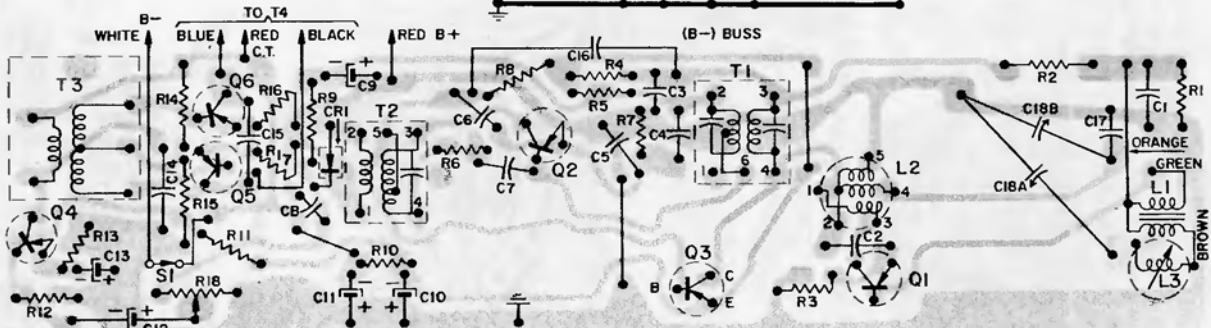

View of Printed Wiring Board. NOTE: Gray area represents printed wiring, black symbols and lines represent components, wiring and connections on opposite side.

# Admiral

CHASSIS 7M1  
 MODELS 7M11 · 7M12 · 7M14 · 7M15 · 7M16 · 7M18

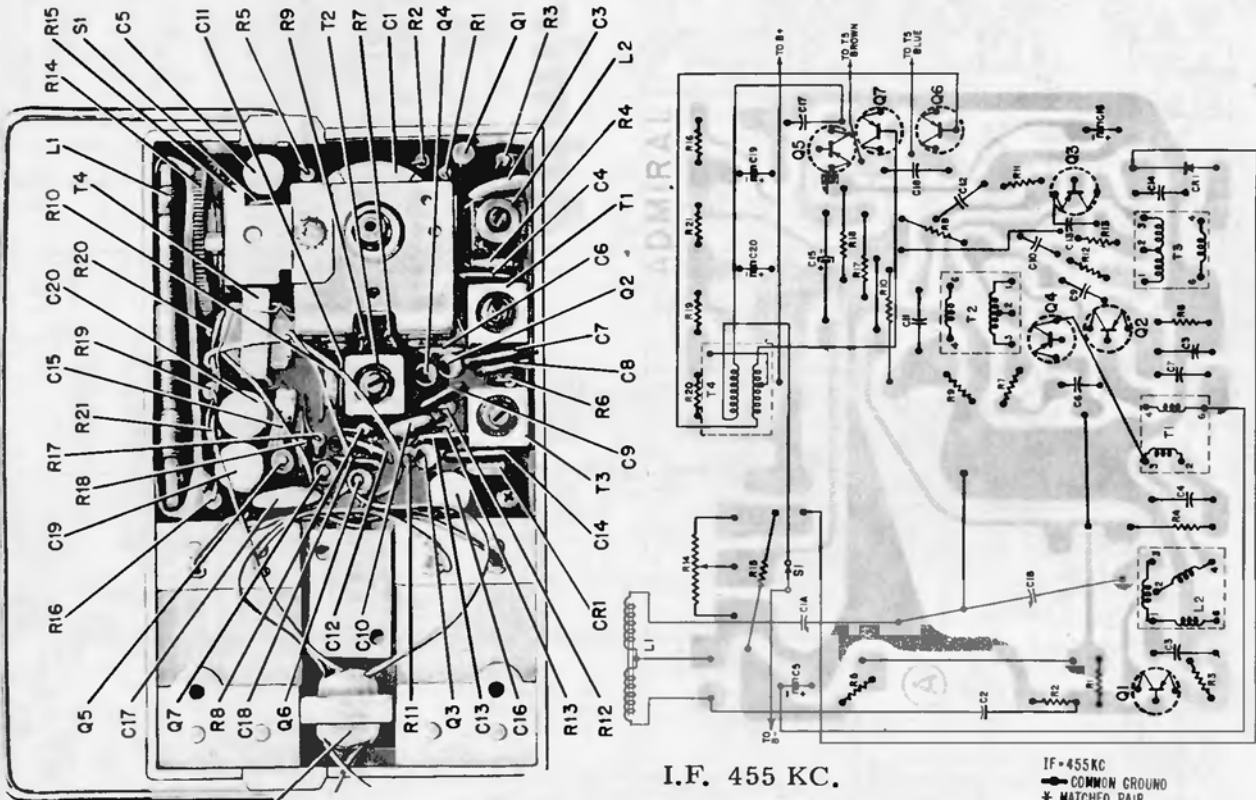

I.F. 455 KC.

IF = 455 KC  
 COMMON GROUND  
 \* MATCHED PAIR

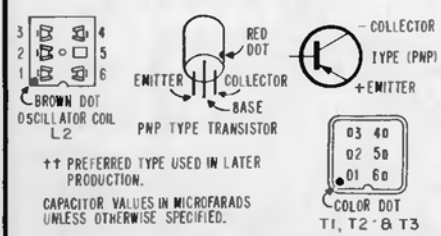
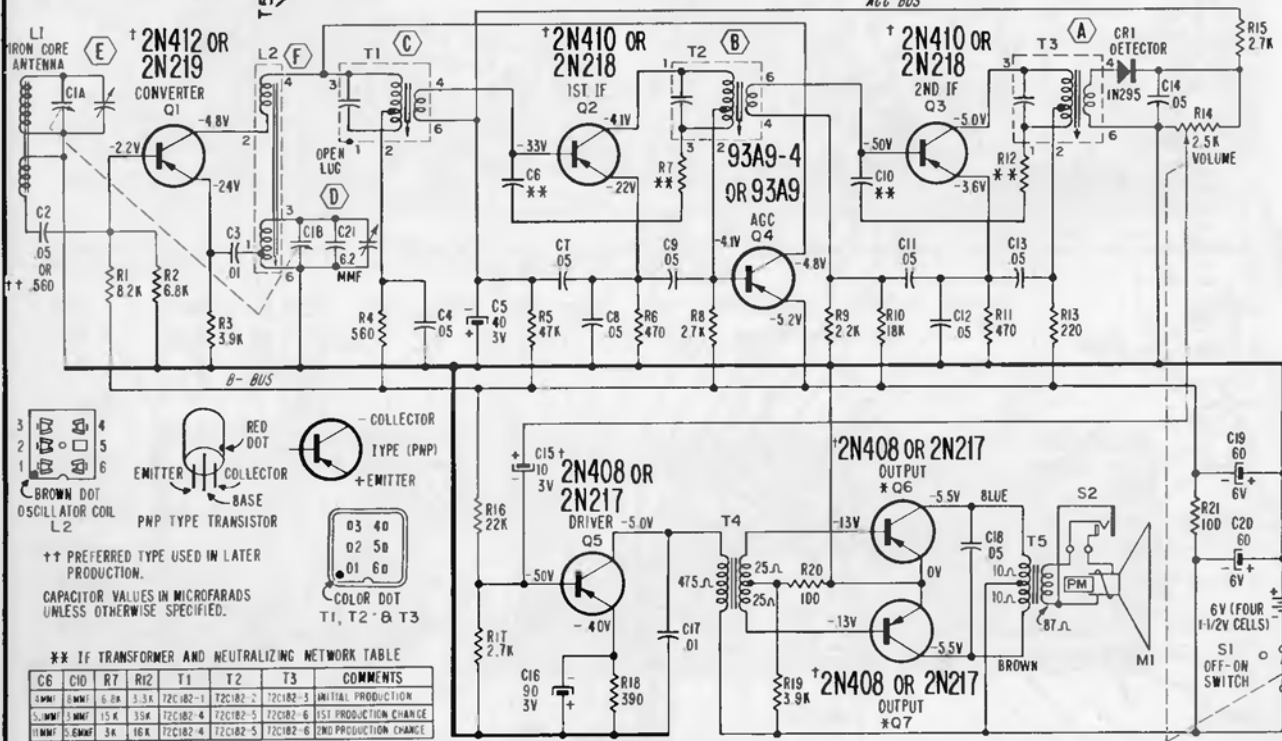

\*\* IF TRANSFORMER AND NEUTRALIZING NETWORK TABLE

C6	C10	R7	R12	T1	T2	T3	COMMENTS
5MNF	5MNF	6.2K	3.3K	72C1B2-1	72C1B2-2	72C1B2-3	INITIAL PRODUCTION
5MNF	5MNF	15K	35K	72C1B2-4	72C1B2-5	72C1B2-6	1ST PRODUCTION CHANGE
5MNF	5MNF	3K	16K	72C1B2-4	72C1B2-5	72C1B2-6	2ND PRODUCTION CHANGE

NOTE: WHEN REPLACING INDIVIDUAL COMPONENTS LISTED IN ABOVE TABLE, DO NOT INTERMIX VALUES OR TYPES NOT LISTED ON THE SAME LINE. ALWAYS REPLACE WITH SAME TYPE USED IN SET.

† 400 SERIES TRANSISTORS USED IN LATER PRODUCTION CHASSIS. INTERCHANGEABLE WITH CORRESPONDING 200 SERIES SHOWN.

TOTAL CURRENT DRAIN WITH NO SIGNAL & VOLUME CONTROL SET AT MINIMUM. 85MA.

# Admiral

CHASSIS 8H1 • 452  
 MODELS 402 • 403 • 404  
 AM I.F. 455 KC.  
 FM I.F. 10.7 MC.

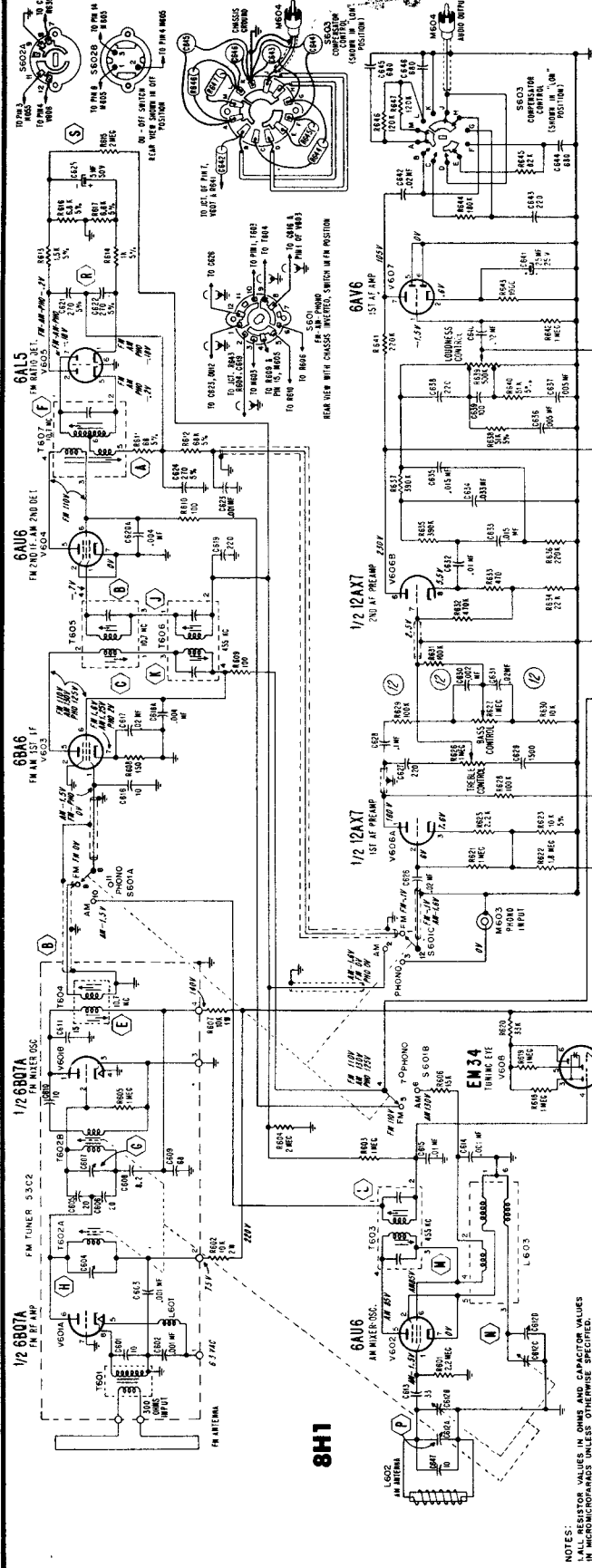
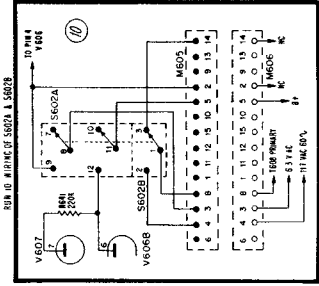

NOTES:  
 1. CAPACITOR VALUES IN MICROFARADS UNLESS OTHERWISE SPECIFIED.  
 2. ALL VOLTAGES TAKEN WITH A VACUUM-TUBE VOLTMETER.  
 3. LOUDNESS CONTROL SET AT MINIMUM; BASS AND TREBLE CONTROL SET AT NO SIGNAL POSITION.  
 4. AMPLIFIER AND TUNER CONNECTED FOR ALL VOLTAGE READINGS.

**RUN CHANGES**

- (1) SECORA wiring changed to eliminate *Er* switching in 1000-unit model.
- (2) R629 was 47K, R630 was 4.7K, C630 was .001 mfd., C 631 was .03 mfd., Changes made to increase bass response.

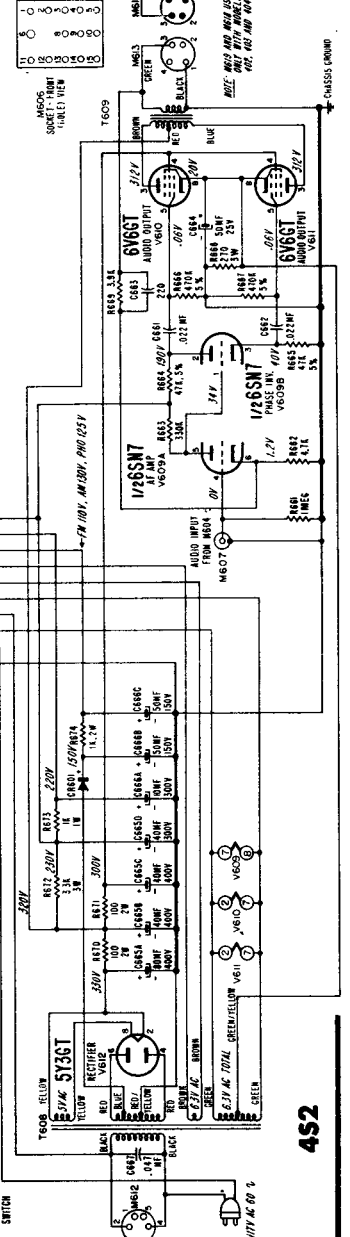



# Admiral 8K1 CHASSIS

Models 231, 237

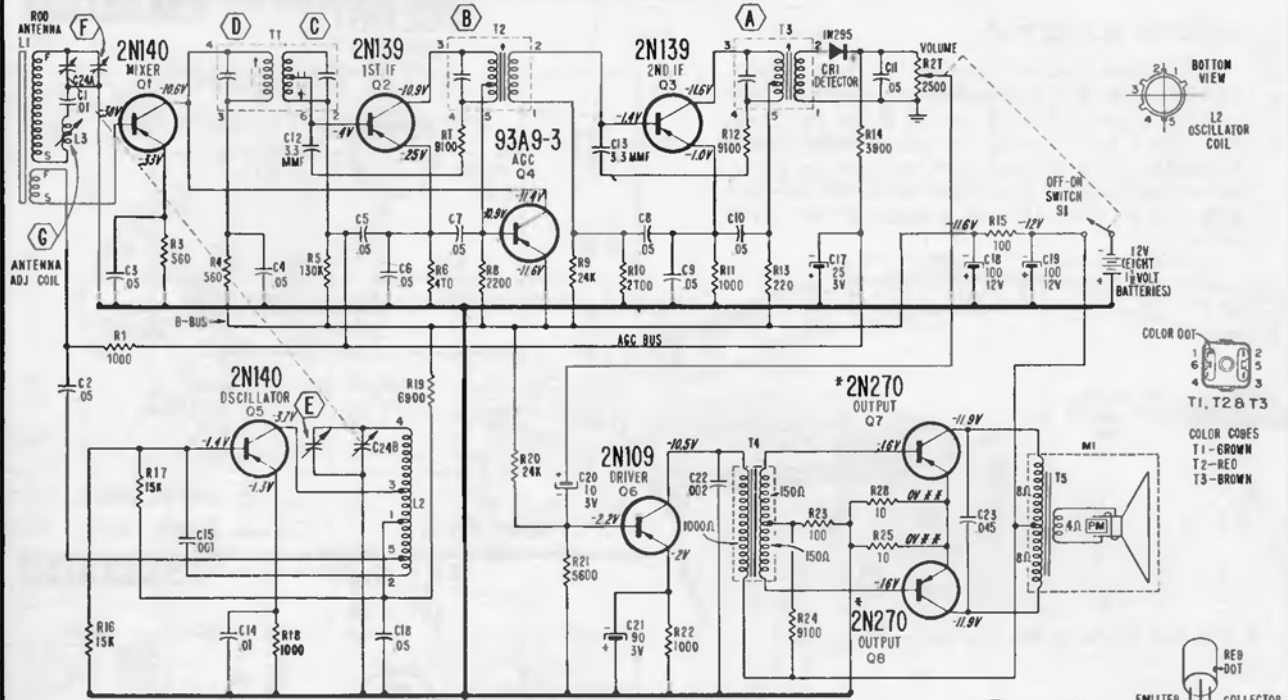

I.F. 455 KC.

IF = 455 KC  
 CHASSIS GROUND  
 COMMON GROUND  
 \* MATCHED PAIR

CAPACITOR VALUES IN MICROFARADS UNLESS OTHERWISE SPECIFIED.  
 # THIS READING MAY BE 0V OR SLIGHTLY NEGATIVE  
 ALL VOLTAGES TAKEN WITH A VTVM

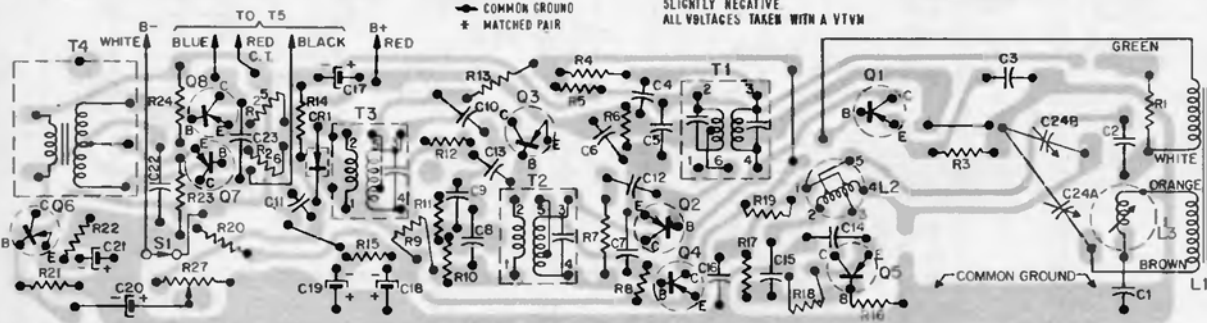
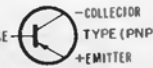

View of Printed Wiring Board. NOTE: Gray area represents printed wiring, black symbols and lines represent components and wiring on opposite side.

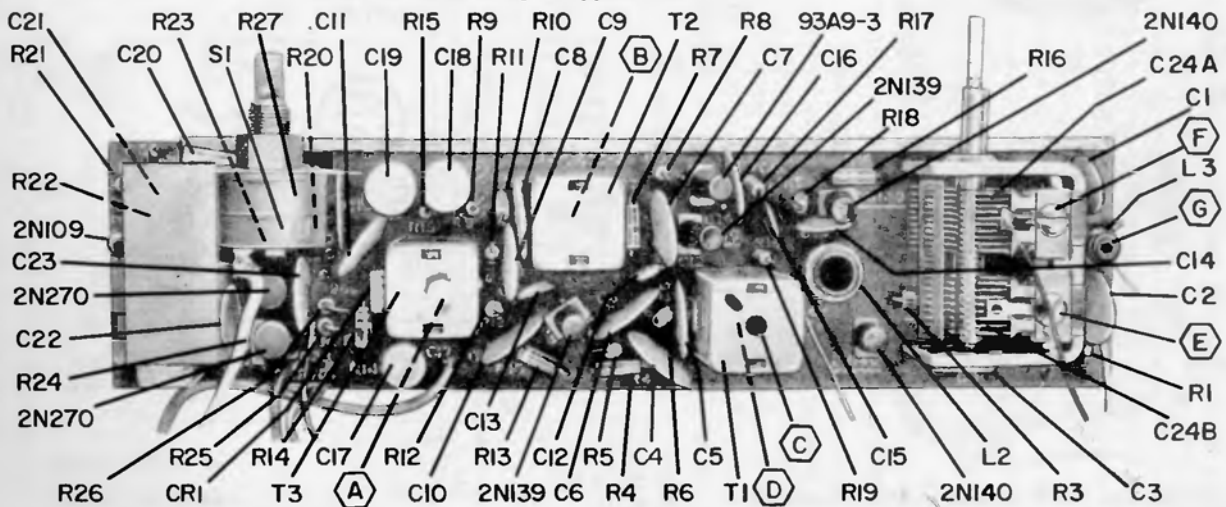

# Admiral

CHASSIS 1B1-1C1-1D1  
 MODELS 1B11-1C12-1C14-1D11-1D12-1E13-1E14

## NEEDLE SELECTOR

The phonograph in models 1D11, 1D12, 1E13 and 1E14 is equipped with two needles; one for playing 16, 33 and 45 RPM records; the other for playing standard "78" RPM records. The phonograph in models 1B11, 1C12 and 1C14 is equipped with two needles and will play 33, 45, and standard "78" RPM records.

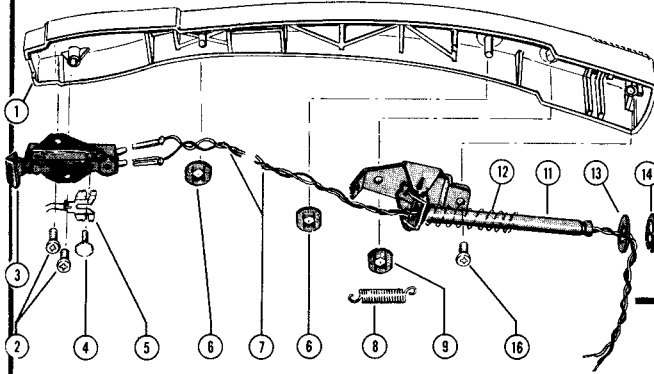

Exploded View of Pickup Arm Assembly.

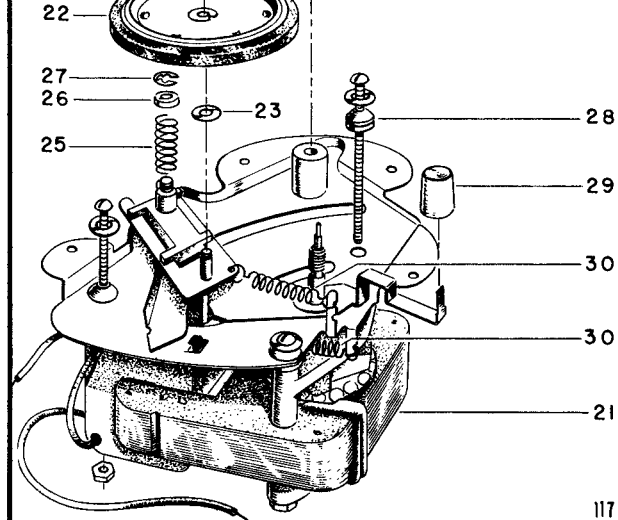
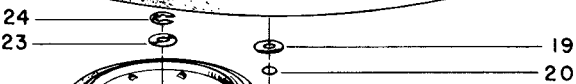
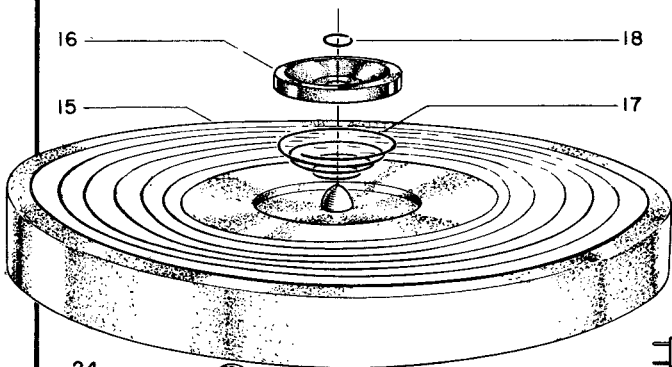

Exploded View of Motor and Turntable.

## 25L6GT AMPLIFIER

1B1 CHASSIS

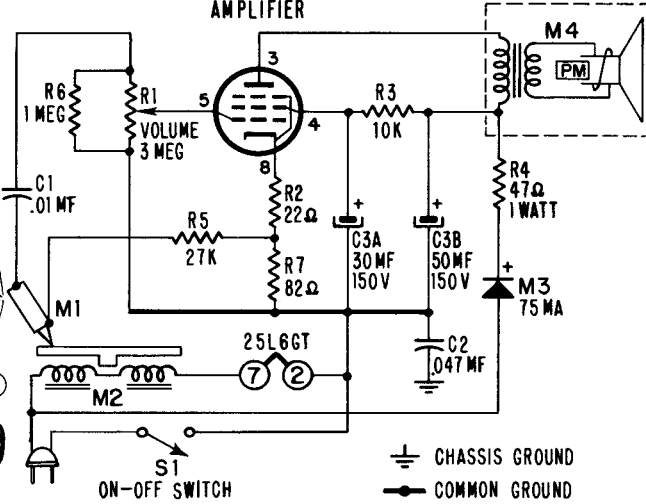

## 25L6GT AMPLIFIER

1C1 CHASSIS

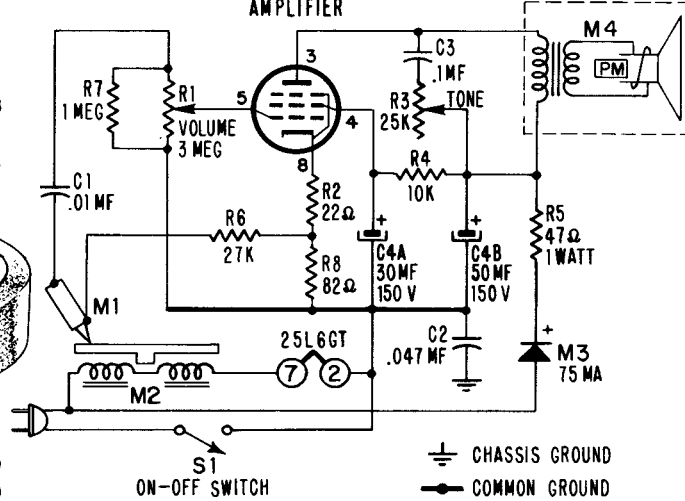

## 25L6GT AMPLIFIER

1D1 CHASSIS

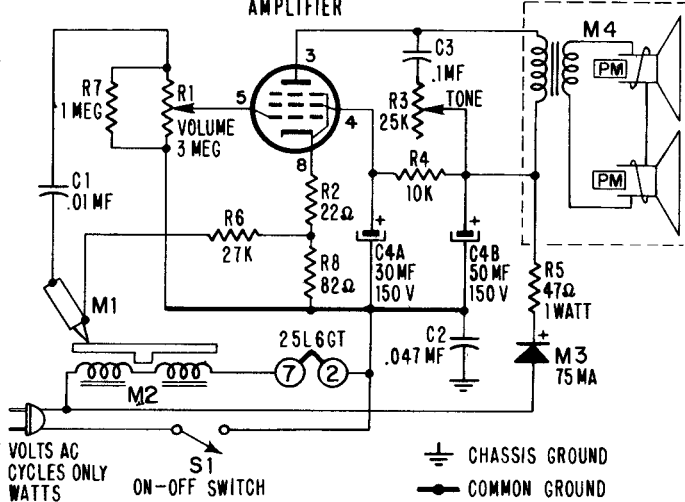

117 VOLTS AC  
 60 CYCLES ONLY  
 45 WATTS

# Admiral

## CHASSIS 3J1A

### PORTABLE PHONOGRAPH

MODEL	COLOR	CHASSIS
331	Black	
335	Red & Gray	3J1A
338	Blue & White	

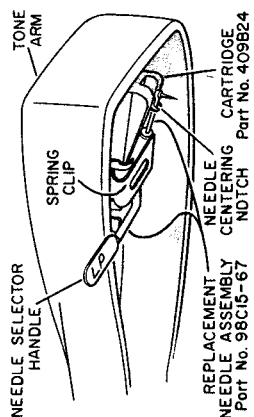
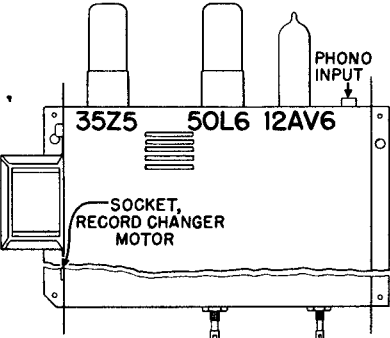
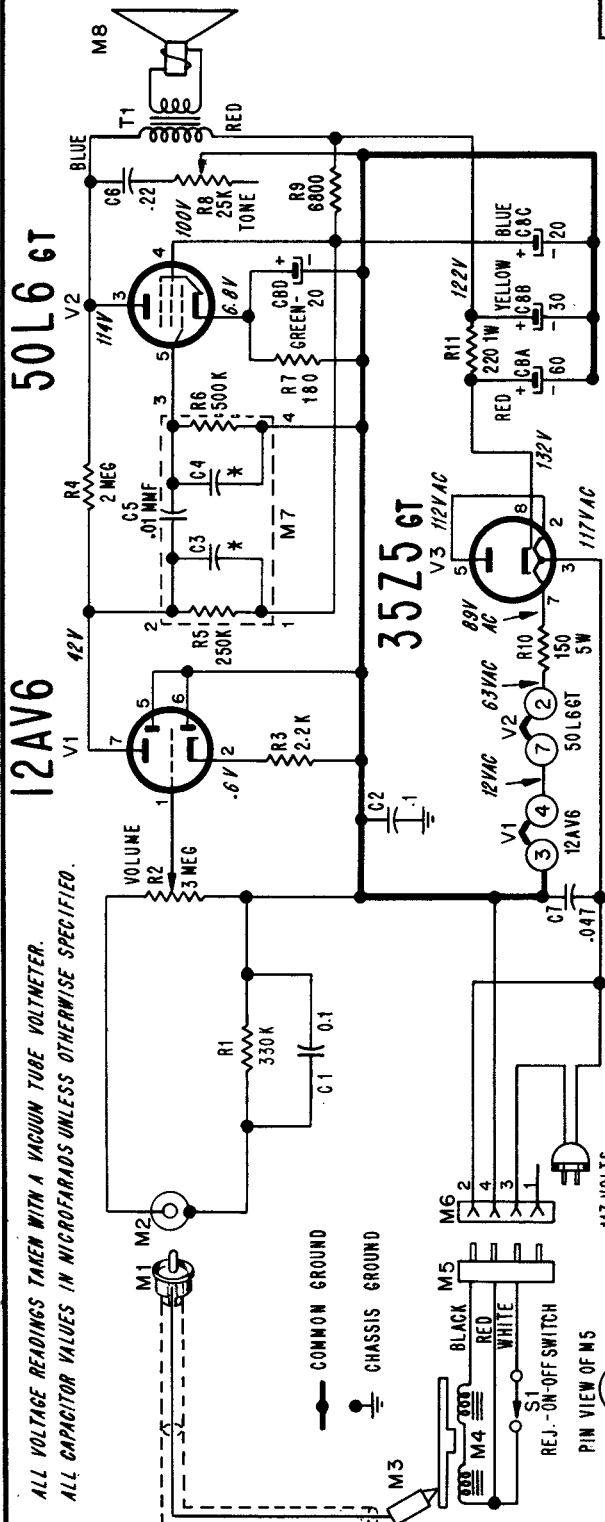

**HUM LEVEL:** Excessive hum can often be minimized by reversing the line cord plug in the wall outlet. Move the **Rej-On-Off** pointer to "ON". Touch the record changer centerpost and note hum level. Reverse the line cord in wall outlet; touch the centerpost and again note hum level. Leave line cord in the position giving the least hum.

**TROUBLE SHOOTING HINTS**

If the phonograph sounds weak or distorted, examine the needles for wear. A worn needle will cause excessive needle scratch and a harshness of treble tones. Test the tubes by substitution and then, if possible, try a new cartridge. Check voltage at tube pins against voltage shown on schematic.

**SERVICE NOTE:** The **Rej-On-Off** pointer (S1) on the record changer is used to turn both amplifier and record changer motor on and off. To turn the amplifier on with the record changer disconnected, a short, temporary jumper wire must be connected from common ground (4) to the single lead from the AC line cord (3) on socket "M6". See schematic.

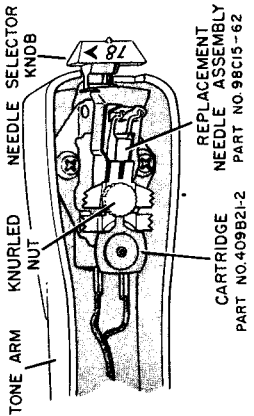

ALL VOLTAGE READINGS TAKEN WITH A VACUUM TUBE VOLTMETER.  
ALL CAPACITOR VALUES IN MICROFARADS UNLESS OTHERWISE SPECIFIED.

# Admiral MODELS 3J14 and 3J16 (3J1 CHASSIS)

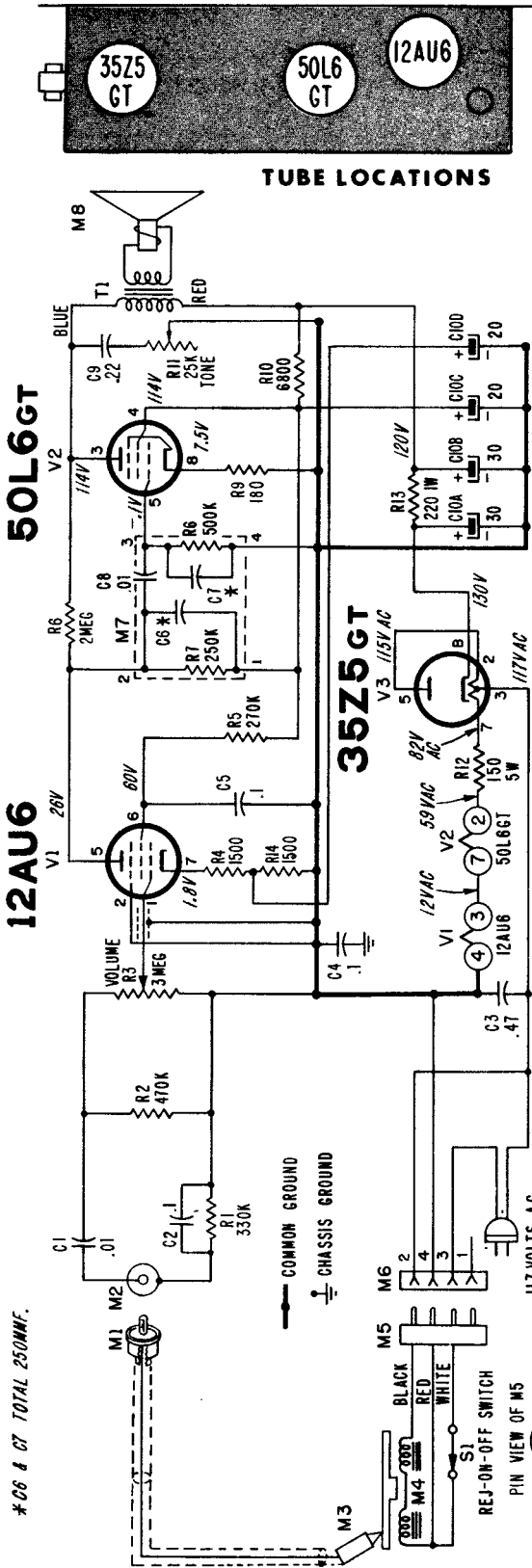

ALL VOLTAGE READINGS TAKEN WITH A VACUUM TUBE VOLTMETER.  
ALL CAPACITOR VALUES IN MICROFARADS UNLESS OTHERWISE SPECIFIED.

### TUBE AND COMPONENT REPLACEMENT

**TO REPLACE TUBES:** Disconnect the AC line plug from the wall outlet. Remove the hold down screws on either side of the record changer platform. Carefully lift the record changer from the cabinet. For convenience, the record changer motor plug and audio input plug may be disconnected from the chassis, and the record changer set aside.

The audio amplifier uses the following tubes: one 12AU6 (first audio), one 35Z5GT (rectifier) and one 50L6GT (audio output). See "Tube Locations".

After servicing tubes, reconnect the record changer motor plug and audio output plug, replace both hold down screws and tighten securely.

**TO REMOVE THE CHASSIS** from the cabinet, follow the procedure outlined under, "To Replace Tubes", then proceed as follows:

Remove the five speaker compartment cover mounting screws and lift the cover from the cabinet.

Remove the three nuts that hold the chassis to the cabinet. Remove the nuts that hold the speaker to the cabinet. The output transformer leads are soldered to the speaker; speaker and chassis must be removed as a unit.

**SERVICE NOTE:** The "REJ-ON-OFF" pointer (S1) on the record changer is used to turn both amplifier and record changer motor on and off. To turn the amplifier on with the record changer disconnected, a short, temporary jumper wire must be connected from common ground (4) to the single lead from the AC line cord (3) on socket "M6". See schematic.

Amplifier voltage readings may also be taken by connecting the record changer motor plug (M5) to the socket (M6) on the chassis. Unclamp the TONE ARM from the tone arm rest and slide the "REJ-ON-OFF" pointer to the "ON" position. Set volume

control for minimum and tone control at the center of its range.

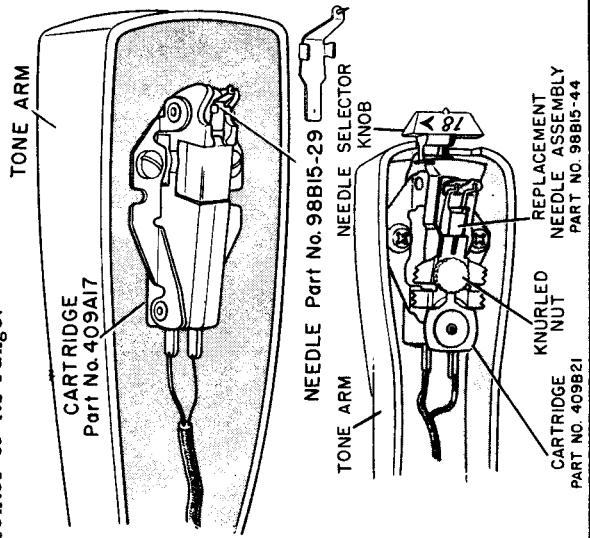

# Admiral

## Chassis 3K1

### HIGH FIDELITY PHONOGRAPH

MODEL	COLOR	CHASSIS
HT2236	Mahogany	3K1
HT2237	Blond	3K1

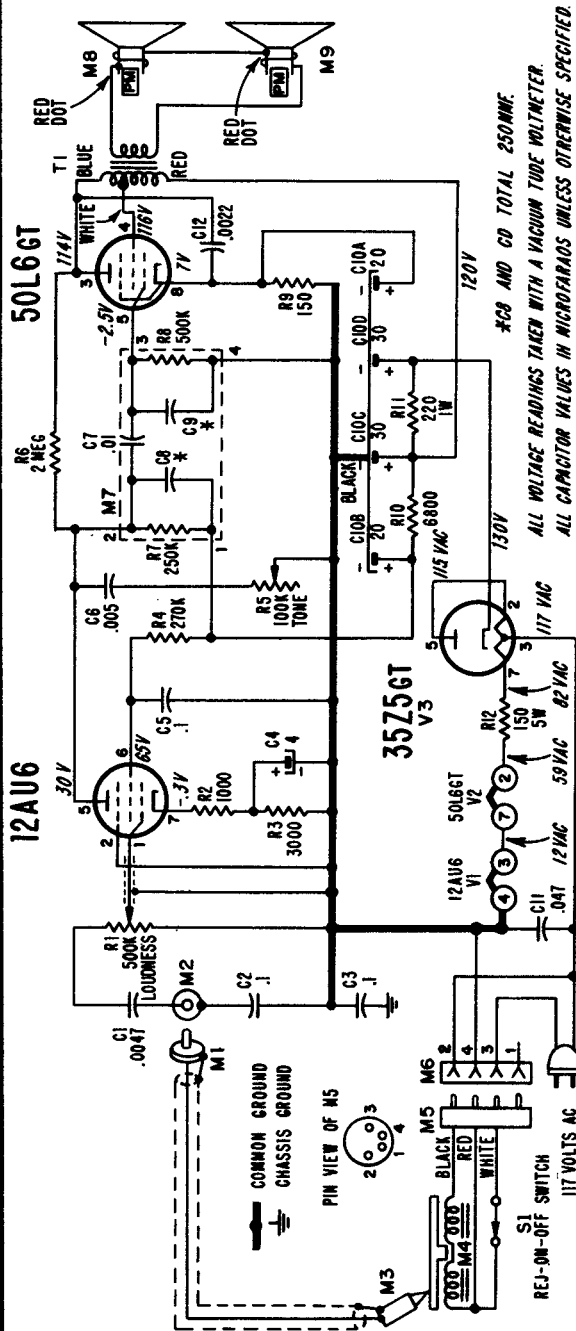

# Admiral CHASSIS 4T2

Models 341, 347, 362, 363, 364, 366, 372, 373

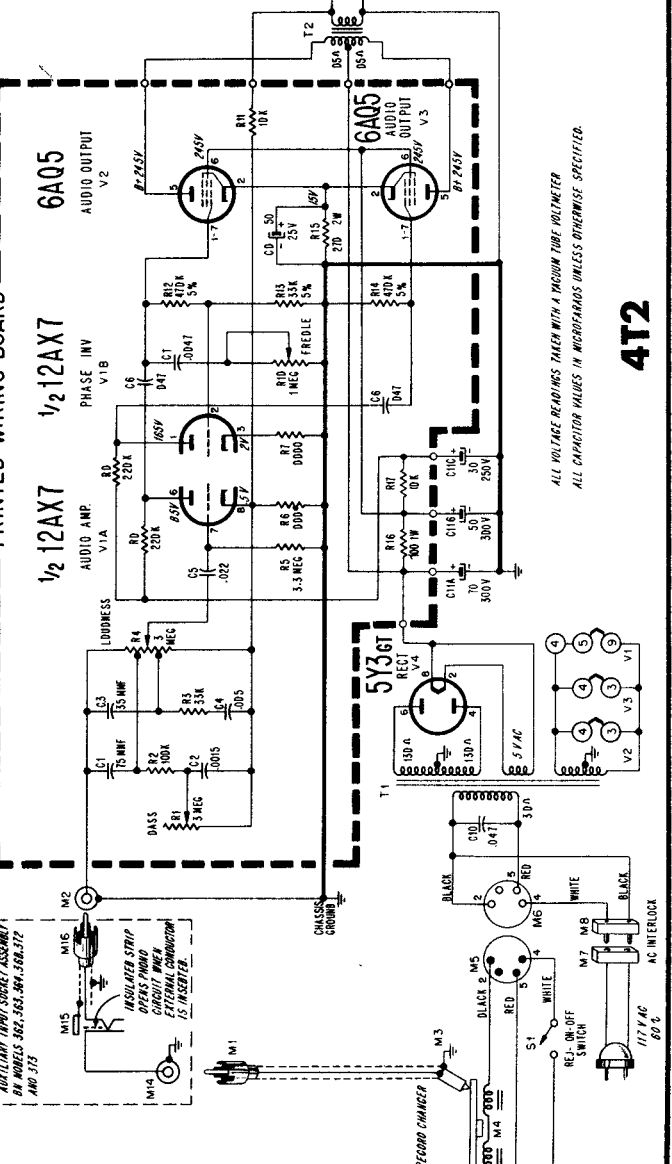
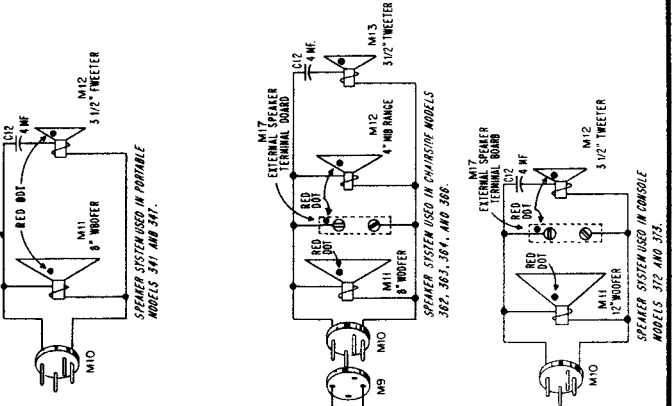
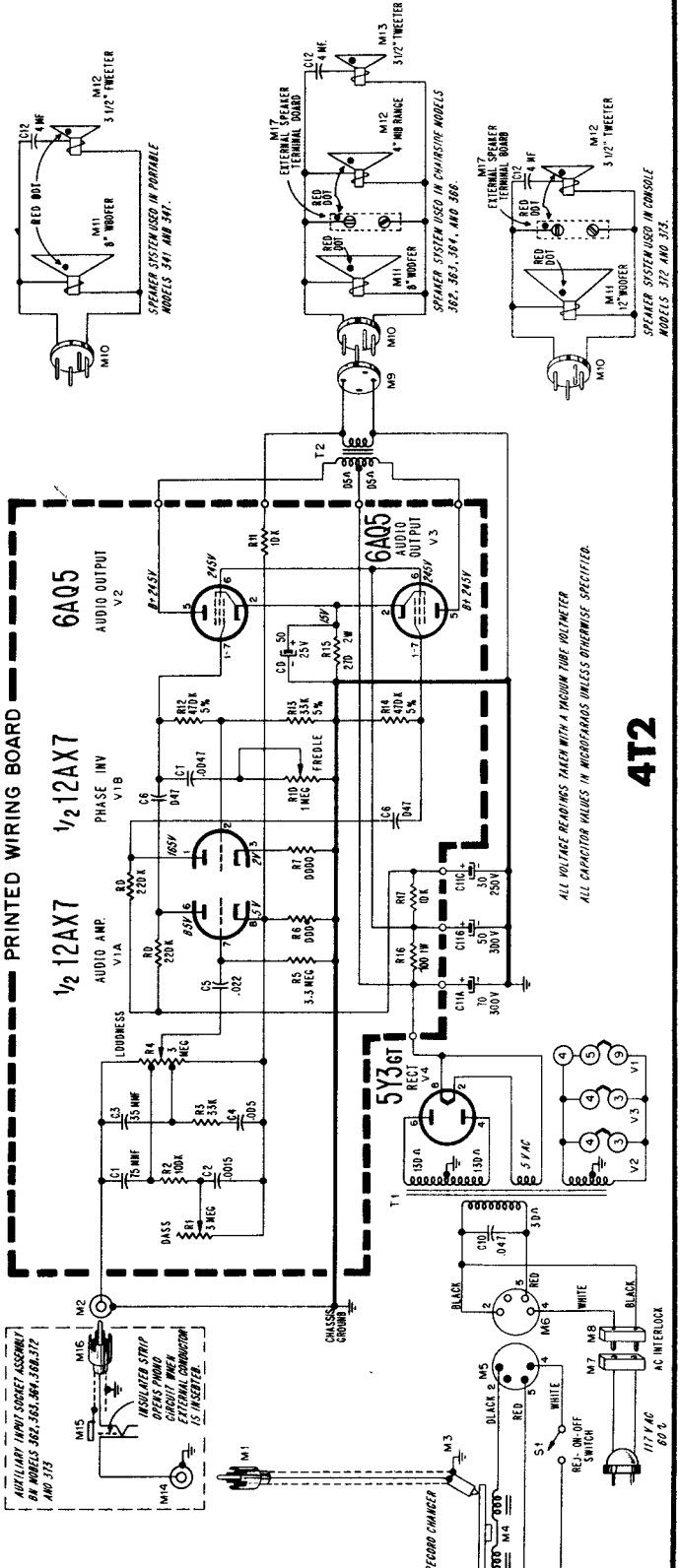



MODEL 1581  
CHASSIS 1.44000

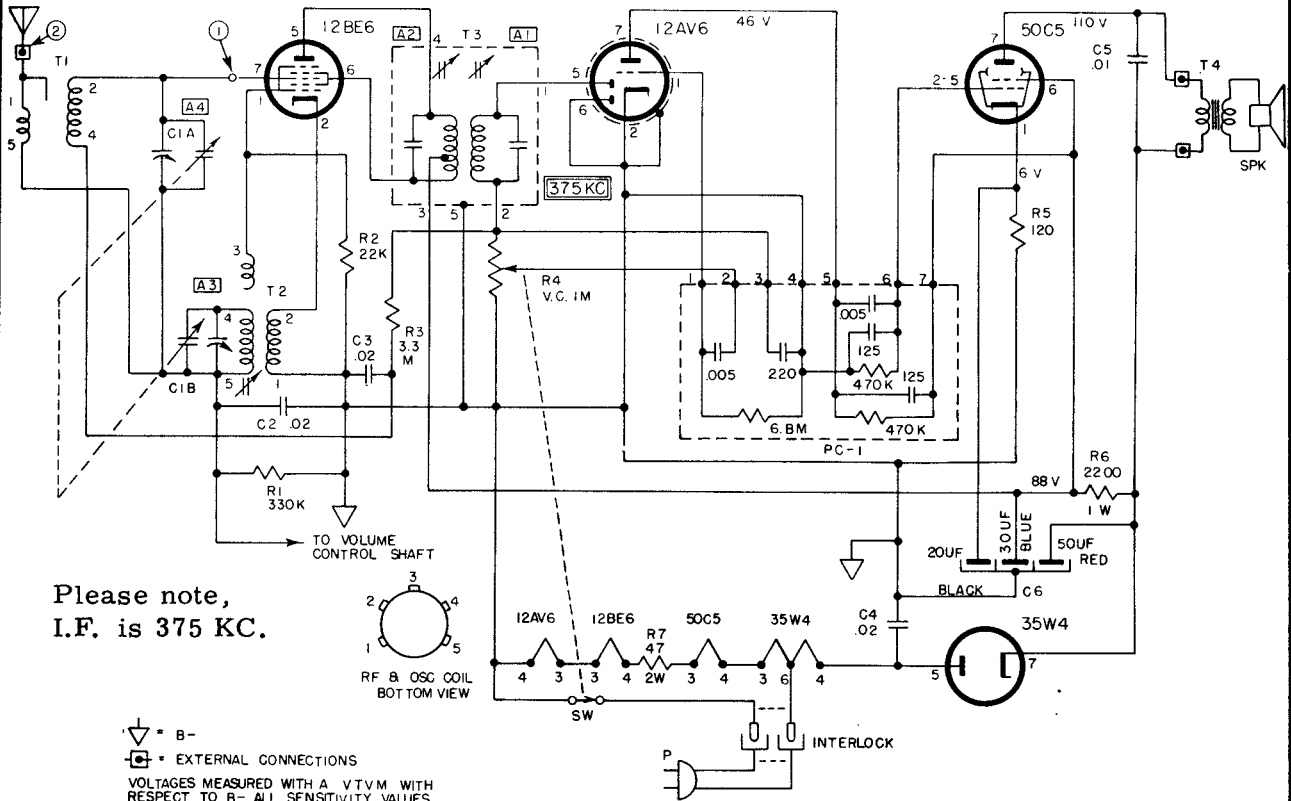

Please note,  
I.F. is 375 KC.

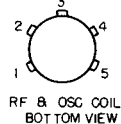

⏚ = B-  
□ = EXTERNAL CONNECTIONS

VOLTAGES MEASURED WITH A VTVM WITH RESPECT TO B- ALL SENSITIVITY VALUES OBTAINED WITH GENERATOR RETURN TO B- RESISTANCE VALUES ARE IN OHMS K=1000, M=1,000,000.

CAPACITANCE VALUES LESS THAN (1) ARE IN MICROFARADS (UF) AND VALUES OF (1) OR GREATER ARE IN MICROMICROFARADS (UUF), UNLESS OTHERWISE INDICATED.

APPROXIMATE SENSITIVITIES

CIRCUIT POINT	DUMMY TO GENERATOR	INPUT FOR .5 WATT OUTPUT (1.26 VOLTS ACROSS V.C.)
1	.05UF AT 375 KC	5000 UV
2	50UUF AT 1000 KC (HANK REMOVED)	350 UV

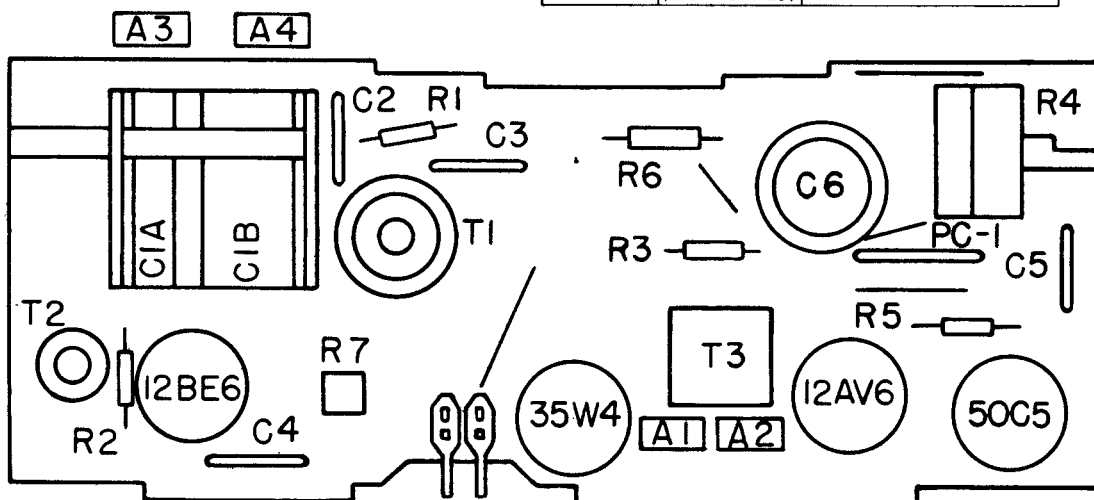

ARVIN INDUSTRIES RADIO MODEL 5578, CHASSIS 1.43500

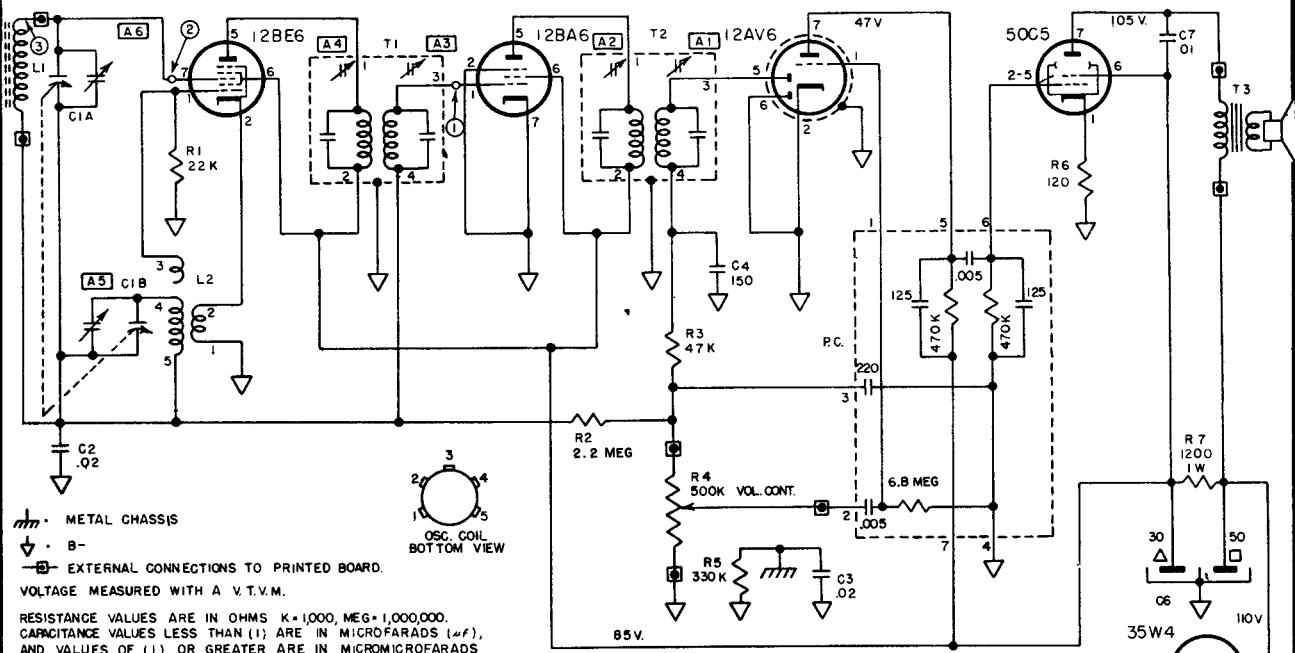

METAL CHASSIS  
 B-  
 EXTERNAL CONNECTIONS TO PRINTED BOARD.  
 VOLTAGE MEASURED WITH A V.T.V.M.

RESISTANCE VALUES ARE IN OHMS K=1,000, MEG=1,000,000. CAPACITANCE VALUES LESS THAN (1) ARE IN MICROFARADS ( $\mu f$ ), AND VALUES OF (1) OR GREATER ARE IN MICROMICROFARADS ( $\mu\mu f$ ), UNLESS OTHERWISE INDICATED.

CIRCUIT POINT	DUMMY TO GENERATOR	INPUT FOR .05 WATT OUTPUT (0.4 VOLTS ACROSS V.C.)	INPUT FOR .5 WATT OUTPUT (1.26 VOLTS ACROSS V.C.)
1	.05 $\mu f$ AT 455 KC	2000 UV	5000 UV
2	.05 $\mu f$ AT 455 KC	60	150
3	STANDARD LOOP AT 1000 KC	200 UV / M	500 UV / M

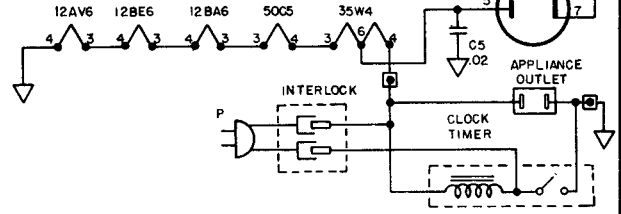

NOTE 1: POSITION OF VARIABLE CONDENSER AT MAXIMUM CAPACITY.

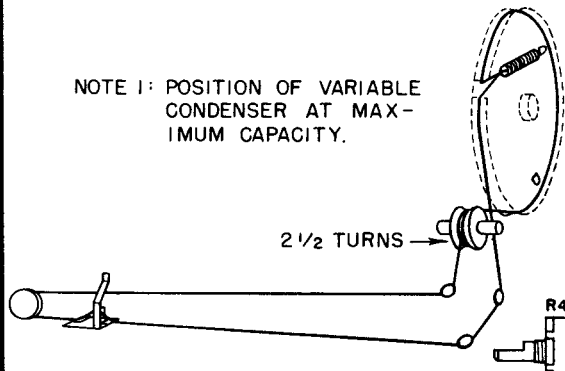

ALIGNMENT PROCEDURE

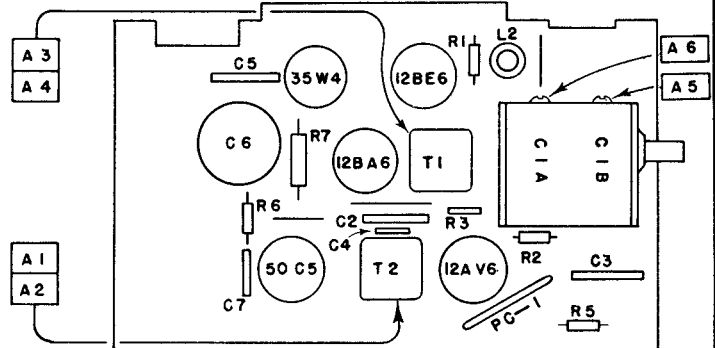

Position of Variable	Frequency of Generator	Dummy Antenna	Generator Output Connection	Trimmers Adjusted in Order Shown for Maximum Output	Function of Trimmer
Open	455 Kc	.05 $\mu f d$	Pin 7 12BE6	A1, A2, A3, A4	I. F. Oscillator Antenna
Open	1670 Kc		* Test Loop	A5	
1400	1400 Kc		* Test Loop	A6	
1000	1000 Kc		* Test Loop	Fan C1A Plates	
600	600 Kc		* Test Loop	Fan C1A Plates	

\* Standard Hazeltine Test Loop Model 1150 or 3 turns of wire about 6" in diameter placed about one foot from the set loop. The alignment procedure should be repeated for greatest accuracy.

VOLUME R-18, MOST-OFTEN-NEEDED 1958 RADIO SERVICING INFORMATION

ARVIN INDUSTRIES, Models 8571, 8573, Chassis 1.41100,  
Model 8572, Chassis 1.41300, is similar.

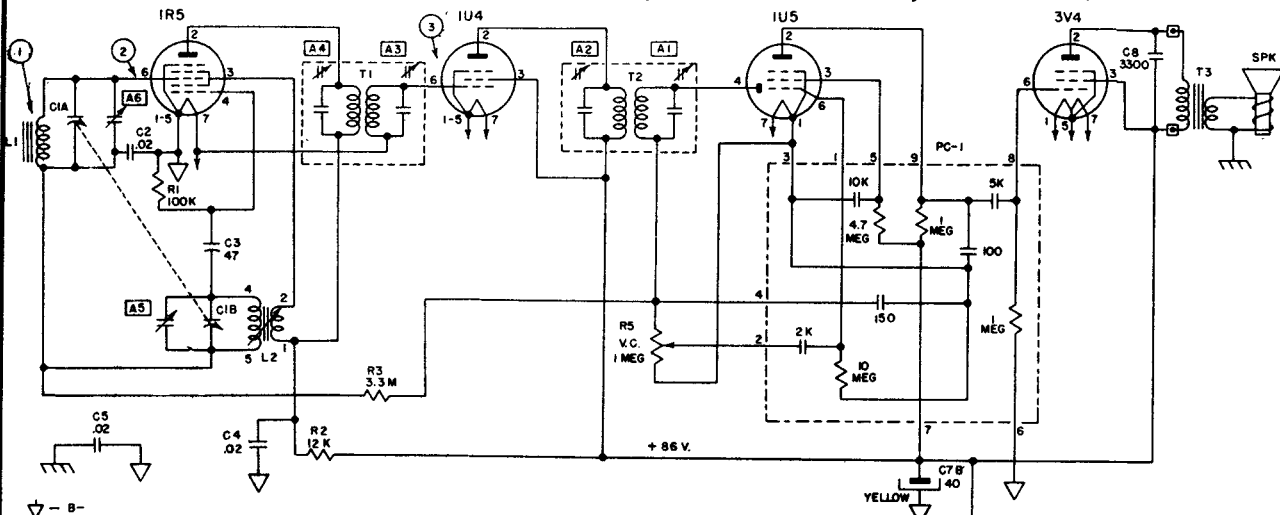

- ▽ - B-
- ⊥ - CHASSIS OR CABINET
- S.1 - SHOWN IN A.C POSITION
- ⊠ - EXTERNAL CONNECTIONS TO BOARD

VOLTAGE READINGS SHOWN AT SOCKET PRONGS ARE TO B- AND ARE TAKEN WITH NO SIGNAL. LINE VOLTAGE AT 117 V. AC, MEASURED WITH VACUUM TUBE VOLTMETER.

RESISTANCE VALUES ARE IN OHMS, K=1,000, MEG=1,000,000. CAPACITANCE VALUES LESS THAN (1) ARE IN MICROFARADS (μf), AND VALUES OF (1) OR GREATER ARE IN MICROMICROFARADS (μμf), UNLESS OTHERWISE INDICATED.

CIRCUIT POINT	DUMMY TO GENERATOR	INPUT FOR .05 WATT OUTPUT (0.4 VOLTS ACROSS VC.)
1	.05μf AT 455 KC	2000 UV
2	.05μf AT 455 KC	50
3	STANDARD LOOP AT 1000 KC	200 UV / M

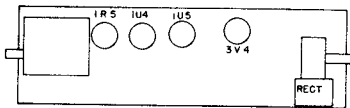
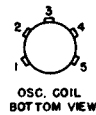

**SPEAKER**

Type: Permanent magnet  
Size: 4 inch  
Voice: Coil Impedance 3.2 Ohms

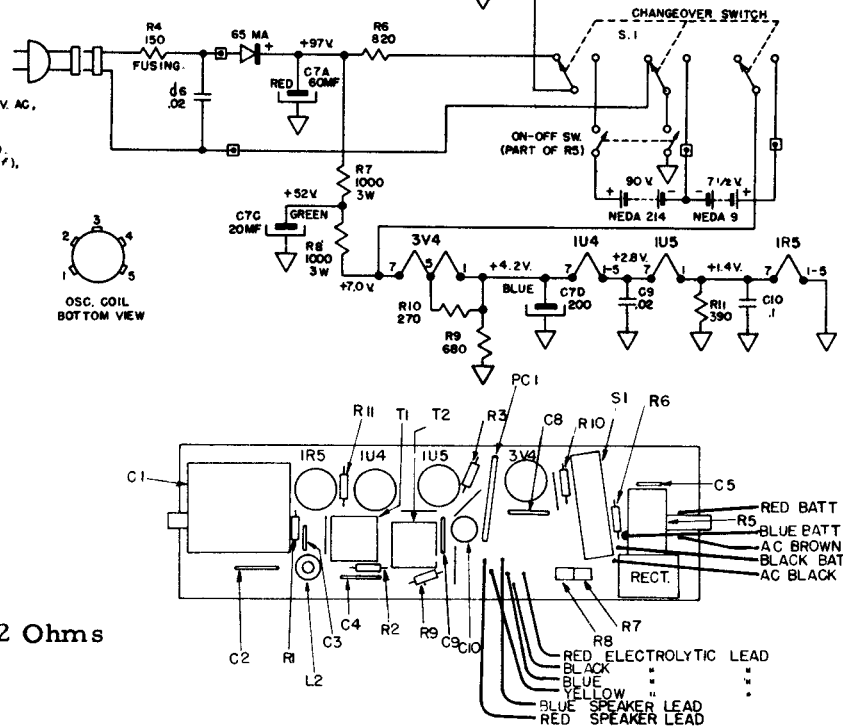

**ALIGNMENT PROCEDURE**

Output meter reading to indicate .05 watt across voice coil ... 0.4V  
Generator ground lead connected ..... floating ground

Position of Variable	Generator Frequency	Dummy Antenna	Generator Connections	Adjust Trimmers (In order shown)	Function of Trimmer
Open	455 Kc	.05 μf	Mixer Grid	A1, A2, A3, A4	I. F.
Open	1670 Kc		* Test Loop	A5	Oscillator
1400 Kc	1400 Kc		* Test Loop	A6	Antenna
600 Kc	600 Kc		* Test Loop	Check Point	

\* Standard Hazeltine Test Loop Model 1150 or 3-turns of wire about 6" in diameter placed about one foot from the set loop.



ARVIN INDUSTRIES RADIO MODEL 8576, CHASSIS 1.41400

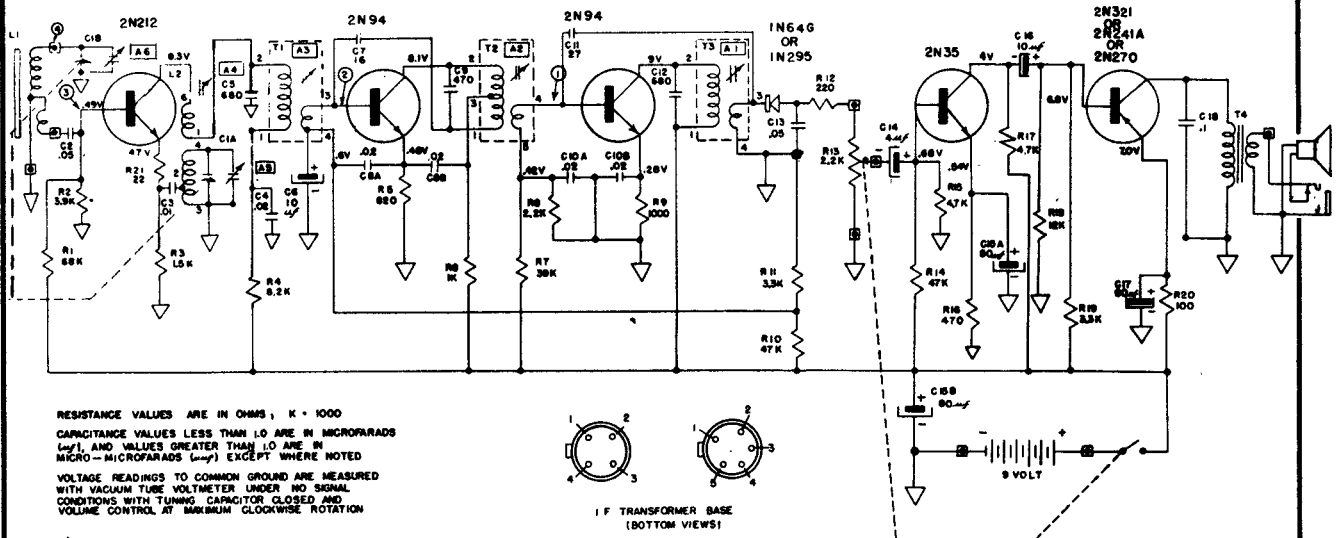

RESISTANCE VALUES ARE IN OHMS, K = 1000  
 CAPACITANCE VALUES LESS THAN 1.0 ARE IN MICROFARADS ( $\mu f$ ), AND VALUES GREATER THAN 1.0 ARE IN MICRO-MICROFARADS ( $\mu\mu f$ ) EXCEPT WHERE NOTED  
 VOLTAGE READINGS TO COMMON GROUND ARE MEASURED WITH VACUUM TUBE VOLTMETER UNDER NO SIGNAL CONDITIONS WITH TUNING CAPACITOR CLOSED AND VOLUME CONTROL AT MAXIMUM CLOCKWISE ROTATION

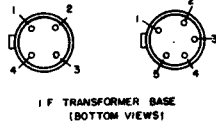

▽ - COMMON GROUND SYMBOL.

□ - EXTERNAL CONNECTION TO PRINTED CIRCUIT

SIGNAL TEST POINT	TEST FREQUENCY	SERIES CAPACITOR TO GENERATOR	INPUT FOR .02 WATT OUTPUT (0.5 V ACROSS VC)
①	455 KC	.05 $\mu f$	4 $\mu v$
②	455 KC	.05 $\mu f$	70 $\mu v$
③	455 KC	.05 $\mu f$	2000 $\mu v$
④	1000 KC	STANDARD LOOP	300 $\mu v$

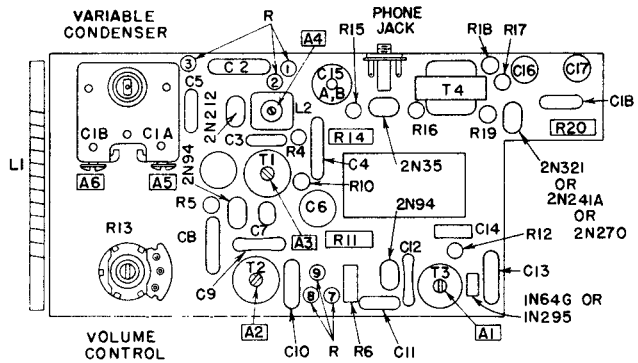
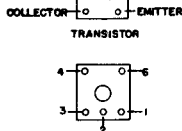

ALIGNMENT PROCEDURE

PRELIMINARY

Output meter reading to indicate 20 milliwatts ..... 0.5V  
 Output meter connection ..... Across speaker voice coil  
 Connection of generator ground lead ..... Common Ground  
 Generator Modulation ..... 30% 40 Cycles  
 Position of Volume Control ..... Fully Clockwise

Position of Variable	Generator Frequency	Dummy Antenna	Generator Connections	Trimmers Adj. in order shown for Max. Output	Function of Trimmer
Open	455 Kc	.05 $\mu f$	C1B	A1, 2, 3, 4	I. F. Oscillator Antenna
Open	1670 Kc		*Test Loop	A5	
1400 Kc	1400 Kc		*Test Loop	A6	
600 Kc	600 Kc		*Test Loop	Check Point	

\*Standard Hazeltine Test Loop Model 1150 or 3 turns of wire about 6" in diameter placed about one foot from the set loop.

The alignment procedure should be repeated in the original order for greatest accuracy. Always keep the output from the signal generator at its lowest possible value to make the AVC action of the receiver ineffective.

ARVIN INDUSTRIES RADIO MODEL 9574, CHASSIS 1.43000

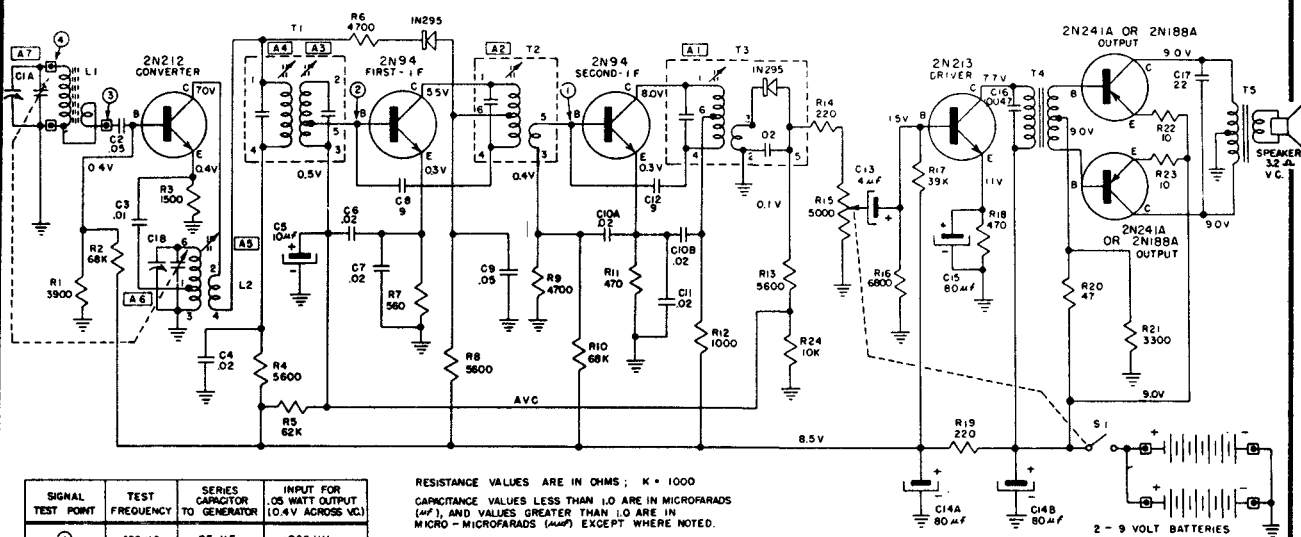

SIGNAL TEST POINT	TEST FREQUENCY	SERIES CAPACITOR TO GENERATOR	INPUT FOR .05 WATT OUTPUT (0.4V ACROSS VC)
①	455 KC	.05 U F	1000 UV
②	455 KC	.05 U F	35 UV
③	455 KC	.05 U F	3 UV
④	1000 KC	STANDARD LOOP	125 UV / M

RESISTANCE VALUES ARE IN OHMS; K = 1000 CAPACITANCE VALUES LESS THAN 1.0 ARE IN MICROFARADS (μF), AND VALUES GREATER THAN 1.0 ARE IN MICRO - MICROFARADS (μμF) EXCEPT WHERE NOTED. VOLTAGE READINGS TO COMMON GROUND ARE MEASURED WITH VACUUM TUBE VOLTMETER UNDER NO SIGNAL CONDITIONS WITH TUNING CAPACITOR CLOSED AND VOLUME CONTROL AT MAXIMUM CLOCKWISE ROTATION

⊥ - COMMON GROUND SYMBOL.

⊠ - EXTERNAL CONNECTION TO PRINTED CIRCUIT

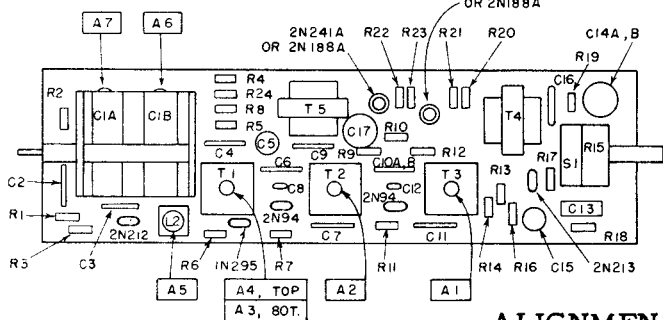
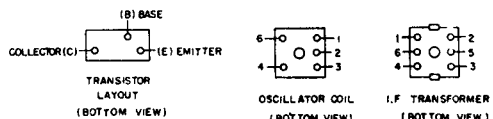

ALIGNMENT PROCEDURE

- Output meter reading to indicate 50 milliwatts ..... 0.4V
- Output meter connection ..... Across speaker voice coil
- Connection of generator ground lead ..... Common Ground
- Generator Modulation ..... 30% 400 cycles
- Position of volume control ..... Fully Clockwise

Position of Variable	Generator Frequency	Dummy Antenna	Generator Connections	Trimmers Adj. in order shown for Max. Output	Function of Trimmer
Open	455 Kc	.05 μf	C1A	A1 (Top of T3) A2 (Top of T2) A3 (Bottom of T1) A4 (Top of T1)	I. F. I. F. I. F. I. F.
Open	1670 Kc		*Test Loop	A6	Oscillator
1400 Kc	1400 Kc		*Test Loop	A7	Antenna
600 Kc	600 Kc		*Test Loop	Check Point	

\* Standard Hazeltine Test Loop Model 1150 or 3 turns of wire about 6" in diameter placed about one foot from the set loop.

# BULOVA

Circuit diagrams of various sets manufactured by Bulova Watch Co. The IF is 455 KC. for these sets.

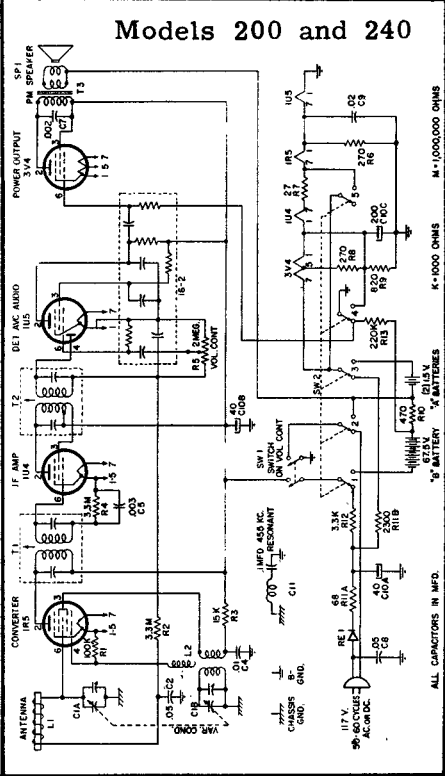
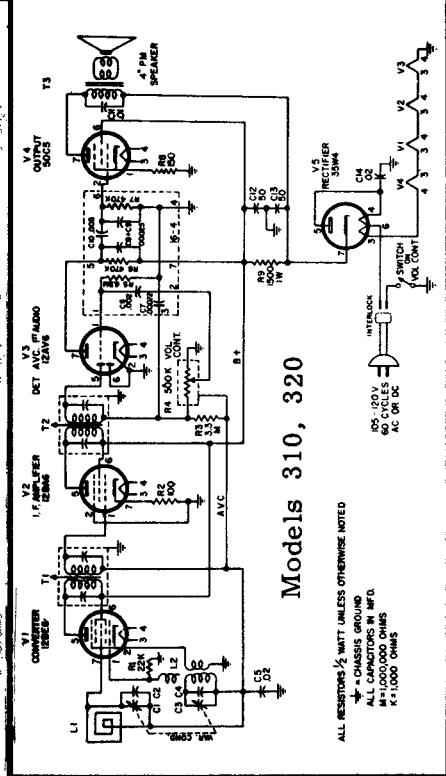
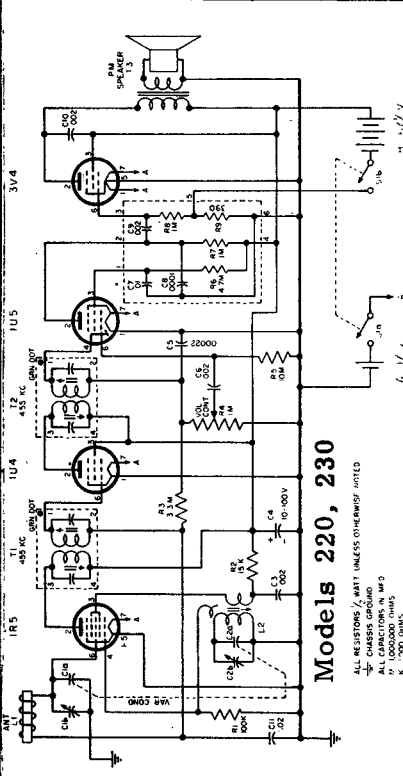
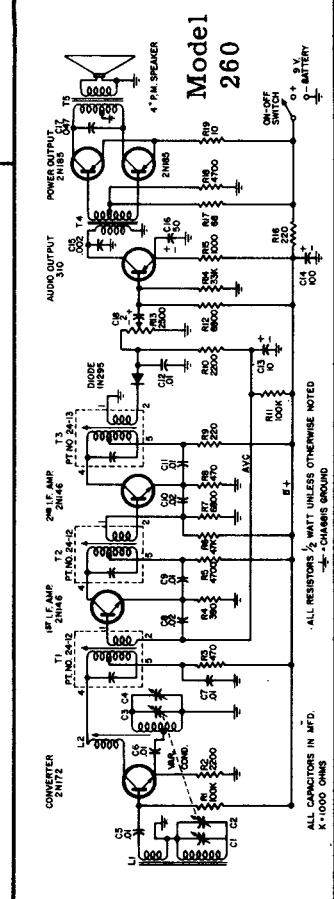
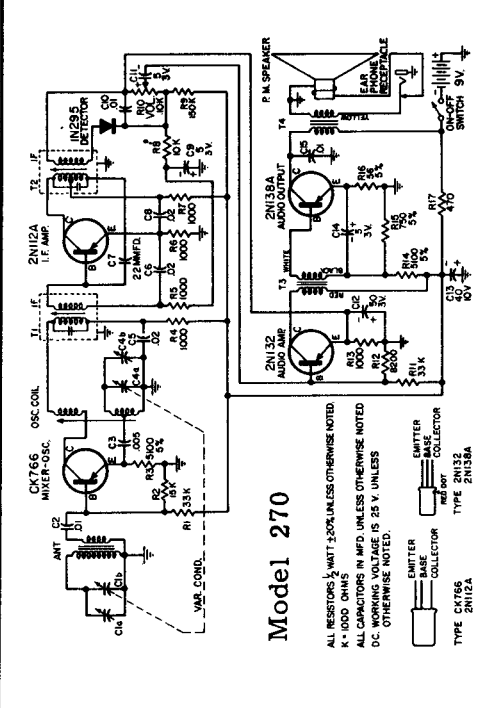
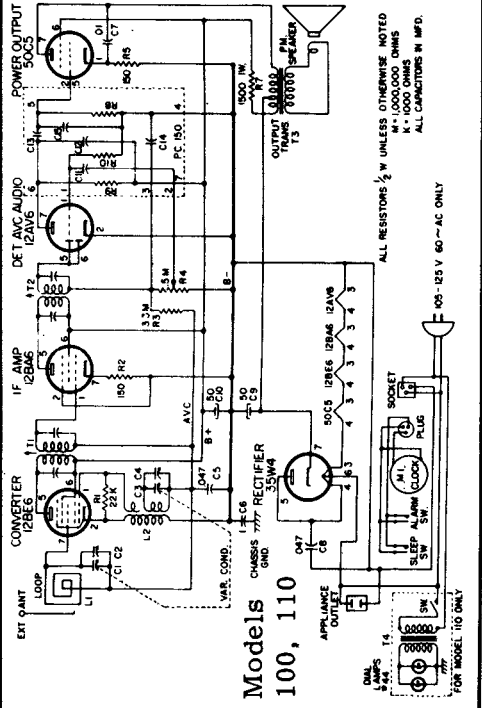

# DELCO

STUDEBAKER  
MODEL AC-2905

CHEVROLET MODEL 987724 is practically identical.

(Continued on page 29)

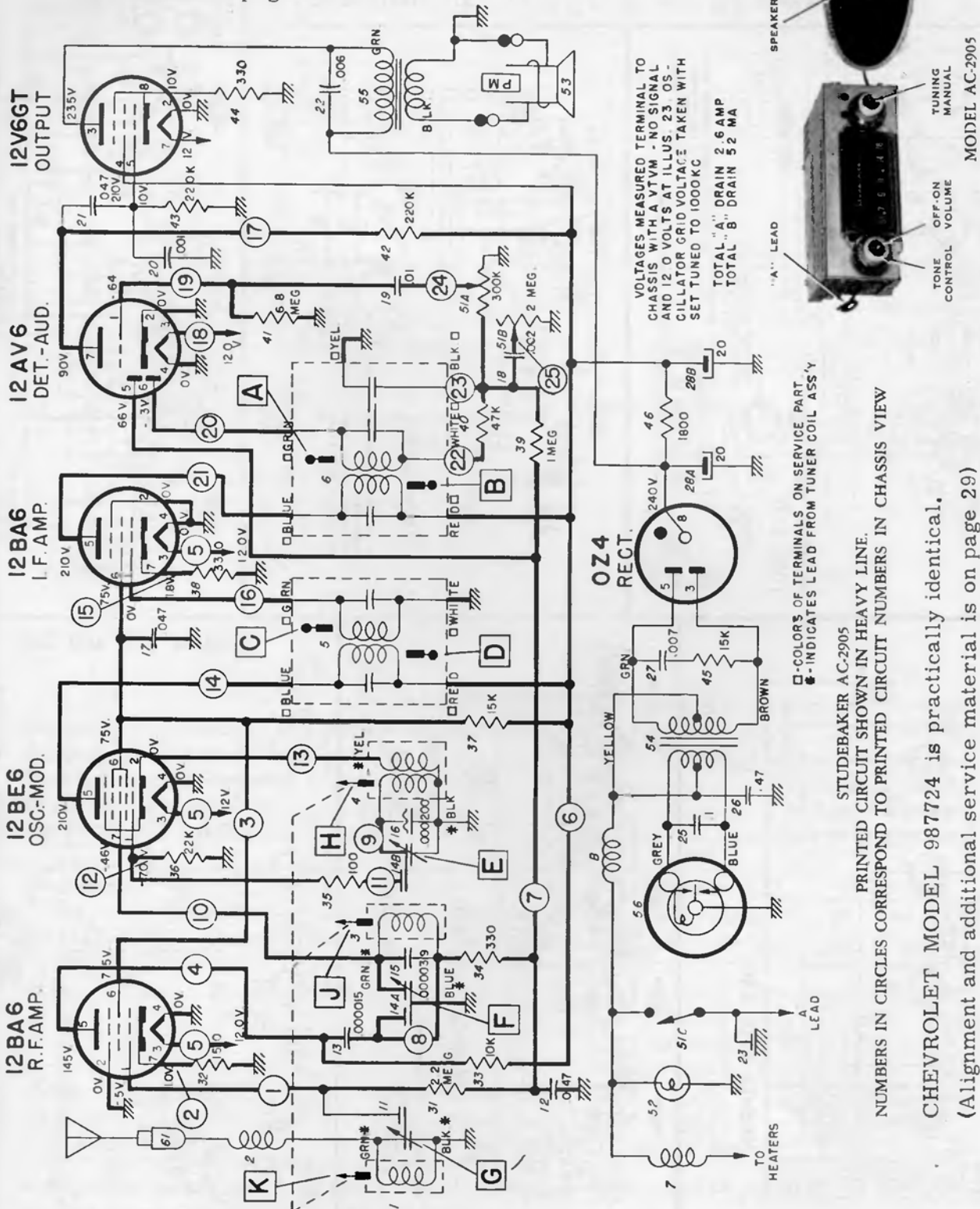

# DELCO

STUDEBAKER Model AC-2905  
 CHEVROLET Model 987724  
 (Continued from page 28)

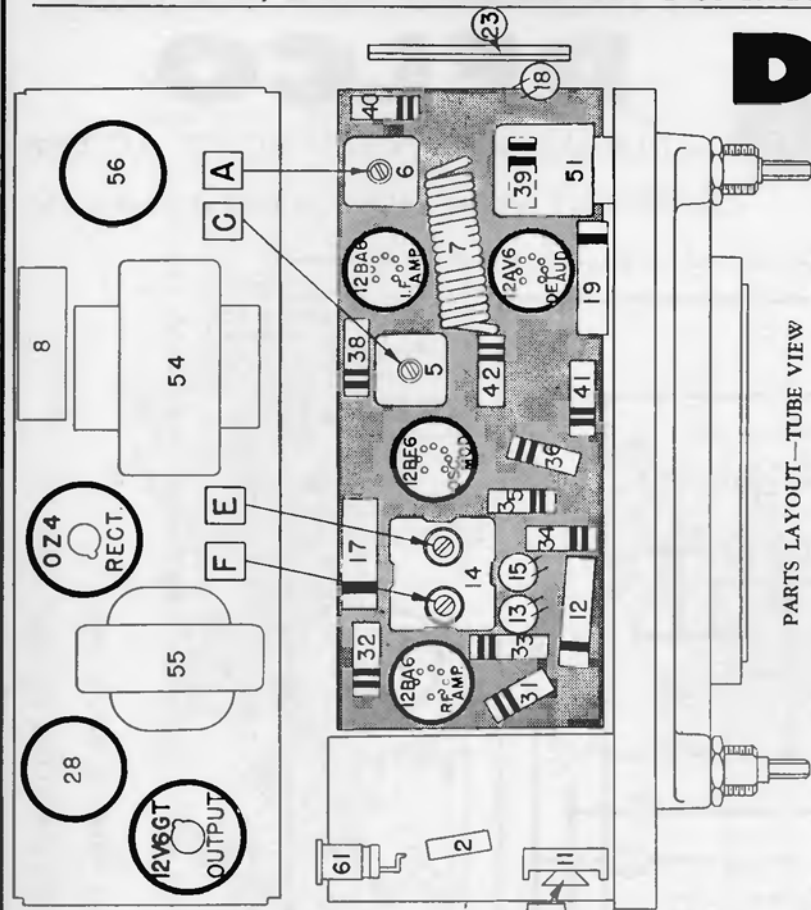

PARTS LAYOUT—TUBE VIEW

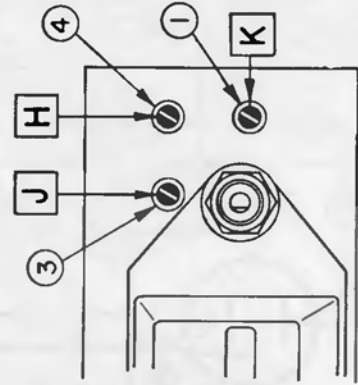

IRON CORE ALIGNMENT

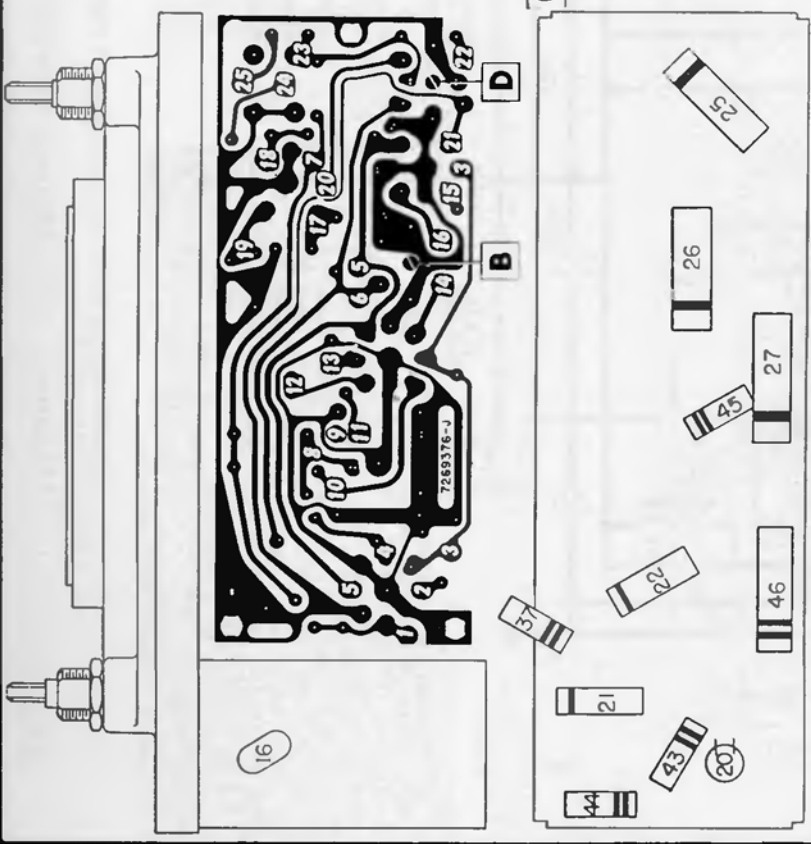

PARTS LAYOUT—CHASSIS VIEW

STEPS	SERIES CAPACITOR OR DUMMY ANTENNA	CONNECT SIGNAL GENERATOR TO	SIGNAL GENERATOR FREQUENCY	TUNE RECEIVER TO	ADJUST IN SEQUENCE FOR MAX. OUTPUT
1	0.1 Mfd.	12BE6 Grid (Pin #7)	262 KC.	High Frequency Stop	A, B, C, D,
2	0.000068 Mfd.	Antenna Connector	1615 KC.	High Frequency Stop	*E, F, G
3	0.000068 Mfd.	Antenna Connector	600 KC.	Signal Generator Signal	J, K
4	0.000068 Mfd.	Antenna Connector	1615 KC.	High Frequency Stop	F, G
5	0.000068 Mfd.	Antenna Connector	1100 KC.	Signal Generator Signal	**

\*Before making this adjustment check mechanical setting of oscillator core "H". The rear of the core should be 1% from the mounting end of the coil form. (This measurement is readily made by inserting a suitable plug in the mounting end of the coil form.) Core adjustment should be made with a non-metallic screw driver.

\*\*Tune in 1100 KC signal and adjust pointer on the dial cord so that the pointer is on the 1100 KC mark of the dial. This setting is to give the correct relationship between the pointer and dial when the radio is installed in a car. With the radio installed and the car antenna plugged in, adjust the antenna trimmer "G" for maximum volume with the radio tuned to a weak station between 600 and 1000 KC (see sticker on case.)

# DELCO

STUDEBAKER-PACKARD MODEL AC-2906

CHEVROLET Model 987727 practically identical.

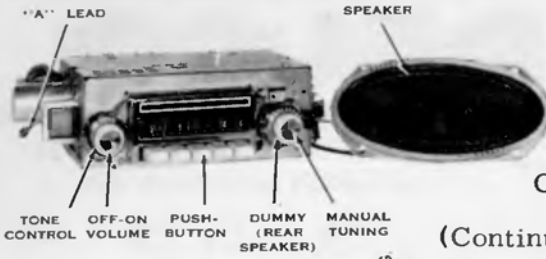

(Continued on page 31)

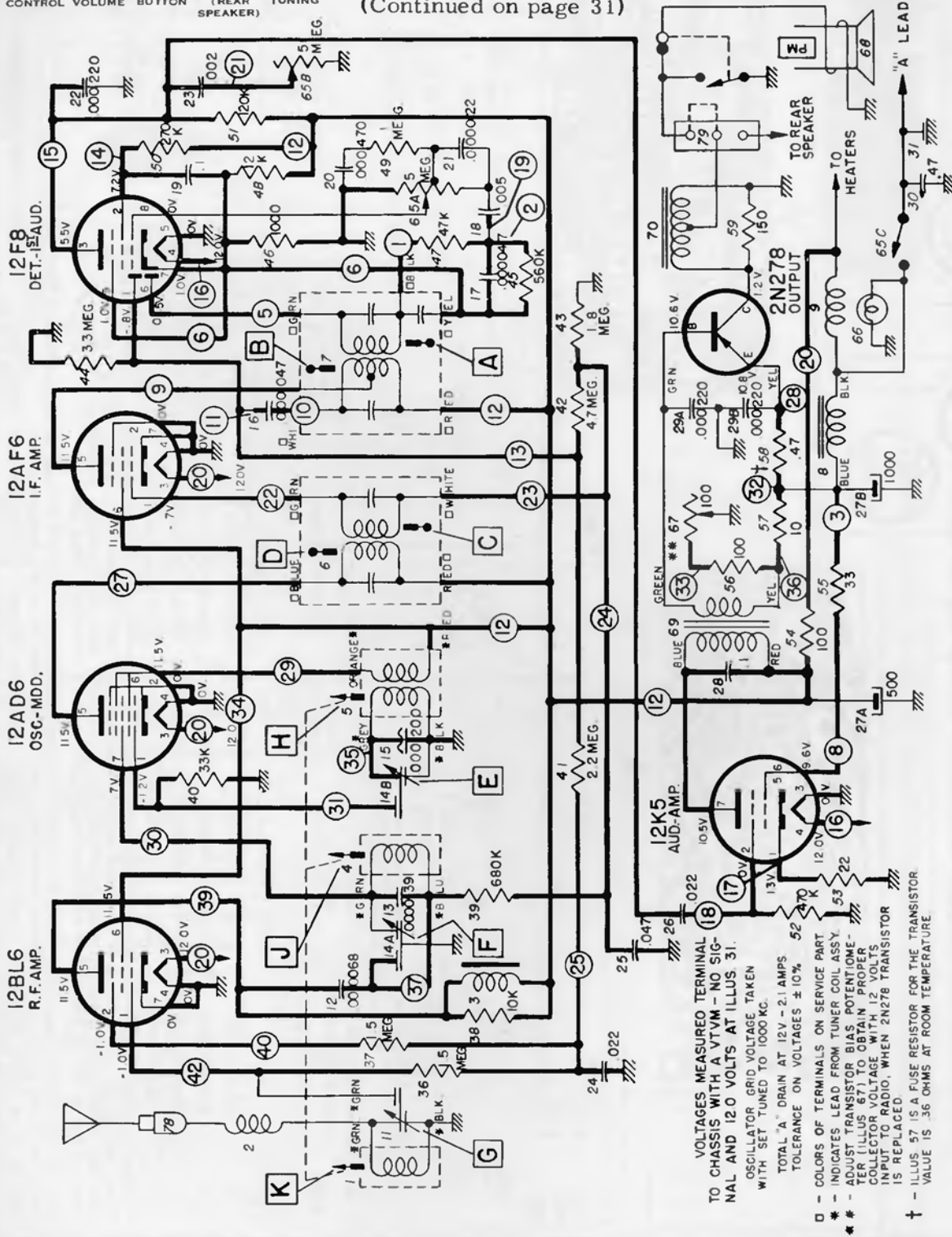

VOLTAGES MEASURED TERMINAL 18 TO CHASSIS WITH A VTVM - NO SIGNAL AND 120 VOLTS AT ILLUS. 31. OSCILLATOR GRID VOLTAGE TAKEN WITH SET TUNED TO 1000 KC. TOTAL "A" DRAIN AT 12V - 2.1 AMPS TOLERANCE ON VOLTAGES ± 10%.

□ - COLORS OF TERMINALS ON SERVICE PART  
 \* - INDICATES LEAD FROM TUNER COIL ASSY.  
 \*\* - ADJUST TRANSISTOR BIAS POTENTIOMETER TO OBTAIN 12 VOLTS COLLECTOR VOLTAGE WITH 12 VOLTS INPUT TO RADIO. WHEN 2N278 TRANSISTOR IS REPLACED.  
 † - ILLUS 57 IS A FUSE RESISTOR FOR THE TRANSISTOR VALUE IS .36 OHMS AT ROOM TEMPERATURE

STUDEBAKER-PACKARD AC-2906—PRINTED CIRCUIT SHOWN IN HEAVY LINES.

(Alignment and additional service information is on page 31)

DELCO RADIO

Studebaker-Packard Model AC-2906,  
Chevrolet 987727 practically identical.

(Continued  
from page 30)

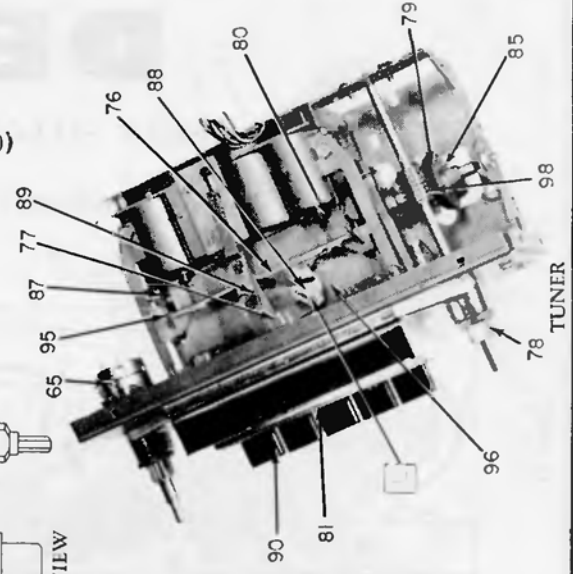
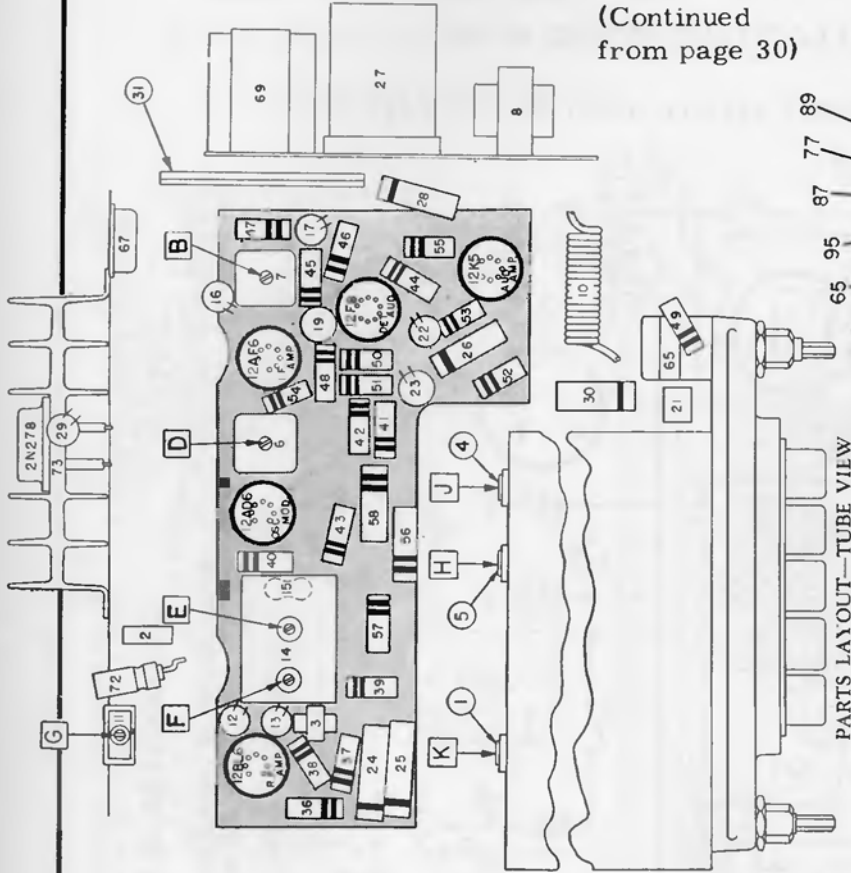

NUMBERS ON PRINTED CIRCUIT BOARD CORRESPOND WITH NUMBERS IN CIRCLES ON SCHEMATIC DIAGRAM.

PARTS LAYOUT—CHASSIS VIEW

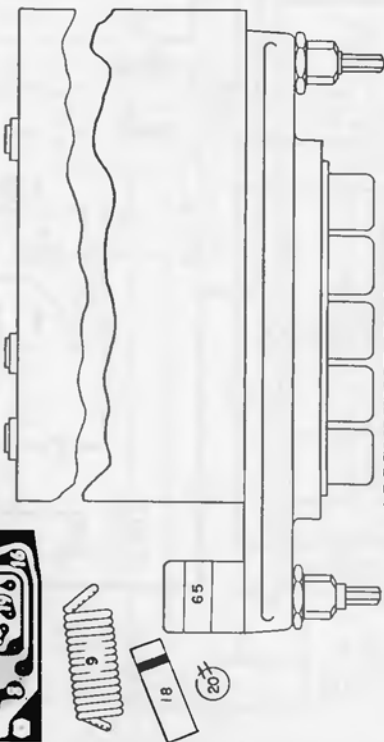
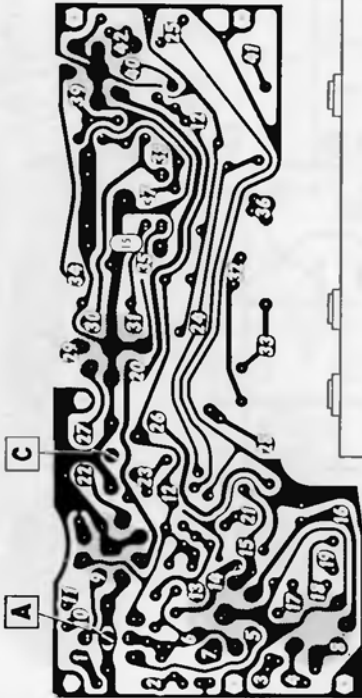

ALIGNMENT PROCEDURE

STEPS	SERIES CAPACITOR OR DUMMY ANTENNA	CONNECT SIGNAL GENERATOR TO	SIGNAL GENERATOR FREQUENCY	TUNE RECEIVER TO	ADJUST IN SEQUENCE FOR MAX. OUTPUT
1	0.1 Mfd.	12AD6 Grid (Pin #7)	262 KC.	High Frequency Stop	A, B, C, D,
2	0.000068 Mfd.	Antenna Connector	1615 KC.	High Frequency Stop	*E, F, G
3	0.000068 Mfd.	Antenna Connector	600 KC.	Signal Generator Signal	J, K
4	0.000068 Mfd.	Antenna Connector	1615 KC.	High Frequency Stop	F, G
5	0.000068 Mfd.	Antenna Connector	1100 KC.	Signal Generator Signal	L**

\*Before making this adjustment check mechanical setting of oscillator core "H". The rear of the core should be 1 1/2" from the mounting end of the coil form. (This measurement is readily made by inserting a suitable plug in the mounting end of the coil form.) Core adjustment should be made with a non-metallic screw driver.

\*\*L is the pointer adjustment which is on the connecting link, between the pointer assembly and core guide bar (See tuner Dwg.). It should be adjusted so that when looking directly at the dial the pointer is on the 1100 KC mark. This setting is to give the correct relationship between the pointer and the dial when the radio is installed in a car. With the radio installed and the car antenna plugged in adjust the antenna trimmer "G" for maximum volume with the radio tuned to a weak station between 600 and 1000 KC (see sticker on case.)

CONNECT VACUUM TUBE VOLTMETER ACROSS SPEAKER VOICE COIL DURING ALIGNMENT.

# DELCO

BUICK SELECTRONIC MODEL 981813

(Alignment and other service material is on page 33)

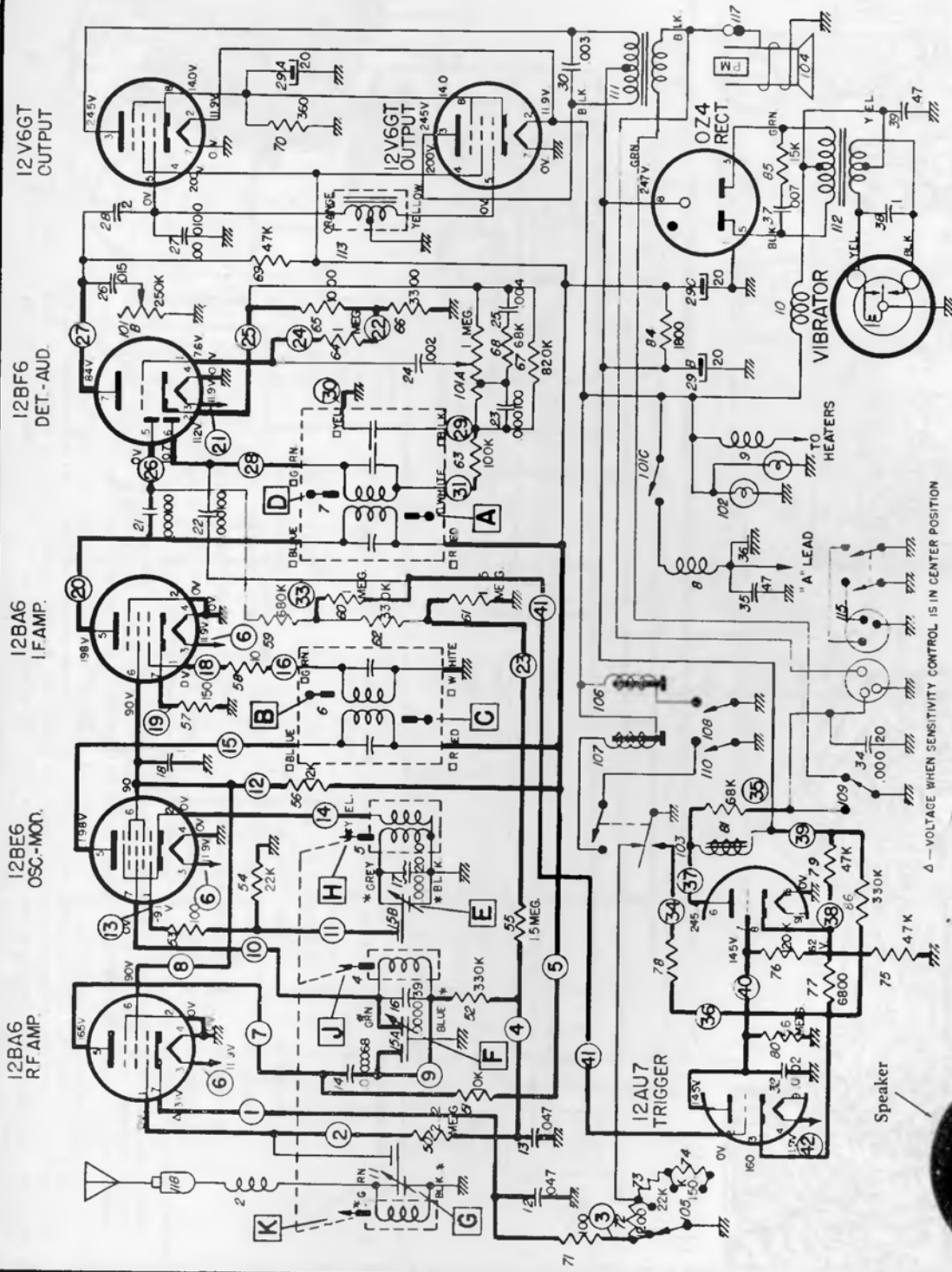

VOLTAGE MEASURED TERMINAL TO CHASSIS  
 WITH A VTVM - NO SIGNAL AND 12.0 VOLTS AT ILLUS  
 36-TUNER STOPPED OSCILLATOR GRID VOLTAGE  
 TAKEN WITH SET TUNED TO 1000 KC

TOTAL "A" DRAIN 3.3 AMPS  
 TOTAL "B" DRAIN 67 MA  
 TOLERANCE ON VOLTAGES - 0.5%  
 TOLERANCE ON RESISTANCES - 10%  
 □ - INDICATES LEAD FROM TUNER COIL ASSY.

**BUICK 981813**  
**PRINTED CIRCUIT SHOWN IN HEAVY LINES**  
**PUSH BUTTON SETUP PROCEDURE**  
 Pull Push Button to the left and out. Tune in  
 desired station manually. Push button all the  
 way in.

△ - VOLTAGE WHEN SENSITIVITY CONTROL IS IN CENTER POSITION





# DELCO

BUICK SELECTRONIC MODEL 981813

(Continued from page 32)

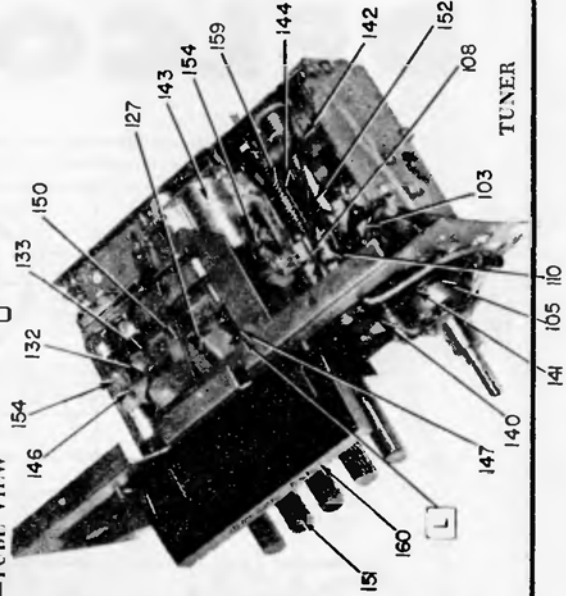
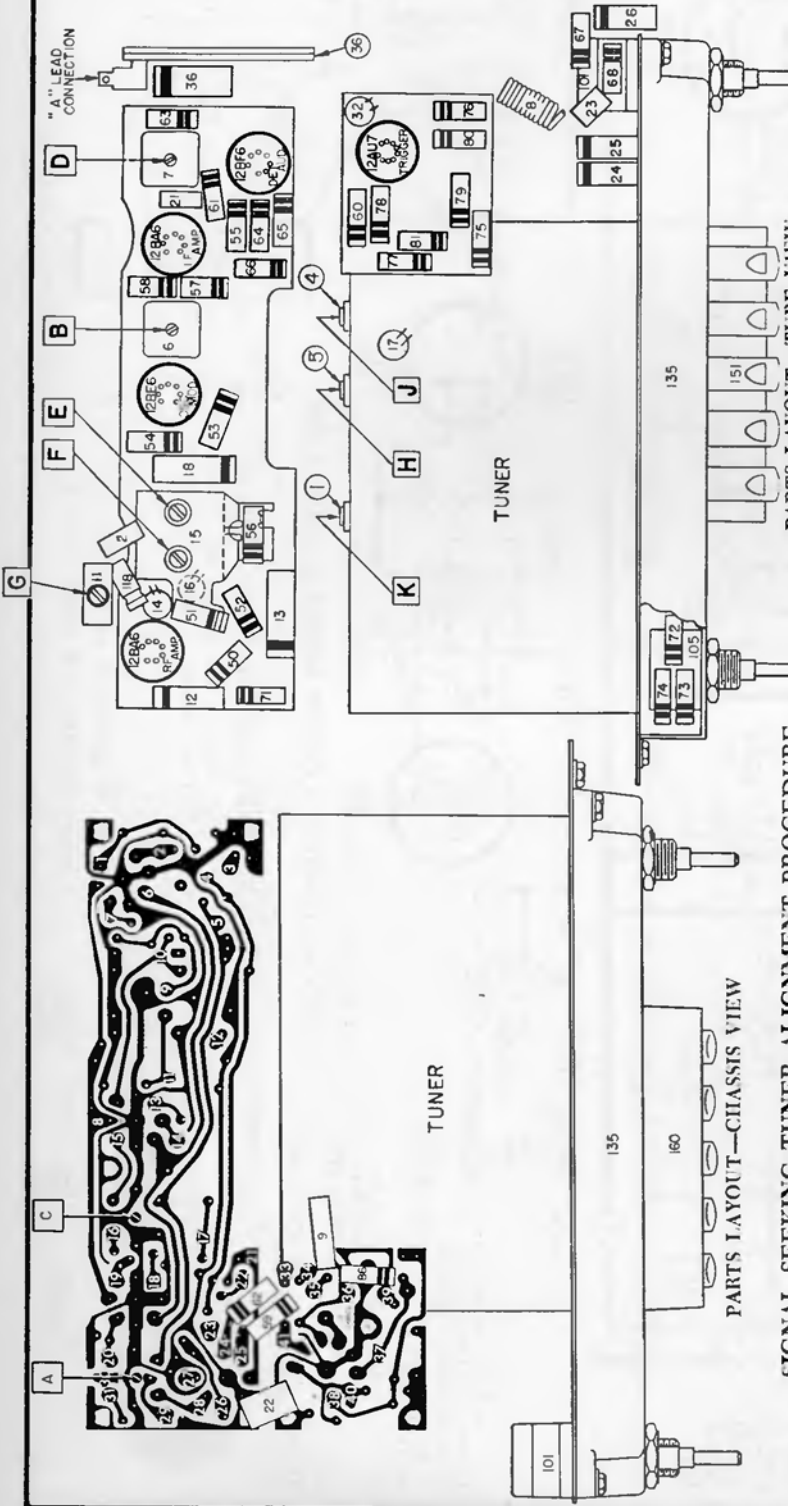

## SIGNAL SEEKING TUNER ALIGNMENT PROCEDURE

Step	Dummy Antenna	Signal Generator To	Signal Generator Frequency	Tune Receiver To	Adjust in Sequence For Output Indicated
1	0.1 Mfd.	12BE6 Grid (Pin 7)	262 KC	*High Frequency Stop	A, B, C (Max.)
2	0.1 Mfd.	12BE6 Grid (Pin 7)	262 KC	High Frequency Stop	D (Min.)
3	.000082 Mfd.	Antenna Connector	1615 KC	High Frequency Stop	**E, F, G (Max.)
4	.000082 Mfd.	Antenna Connector	600 KC	Signal Generator Signal	J, K (Max.)
5	.000082 Mfd.	Antenna Connector	1615 KC	Signal Generator Signal	F, G (Max.)
6	.000082 Mfd.	Antenna Connector	1100 KC	Signal Generator Signal	***L

\*To tune to high frequency, put a 0.012" feeler gauge (or bare #28 wire) in slot against the high frequency stop, depress station selector bar and allow the treadle bar arm to run against the feeler gauge. Turn the radio off and then back on.

\*\*Before making this adjustment, check the setting of oscillator core "H." The rear of the core should be 1 3/8" from the mounting end of the coil form. This measurement is readily made by inserting a suitable plug in the mounting end of the coil form. The core adjustment is made from the mounting end of the coil form with a non-metallic screwdriver. If this adjustment is necessary, first dissolve the glyptal seal on the core stud and be sure to re-seal after making the adjustment.

\*\*\*"I" is the pointer adjustment screw on the end of the core guide bar—adjust so pointer reads 1100 KC. With the radio installed and the antenna plugged in, adjust the antenna trimmer "G" for maximum volume with the radio tuned to a weak station between 600 and 1000 KC (see sticker on case.)

CONNECT A VTVM FROM AVC LINE (#4 ISLAND ON CIRCUIT BOARD) TO GROUND FOR OUTPUT INDICATIONS DURING ALIGNMENT.

# DELCO

BUICK MODEL 981814

BUICK Model 981902 practically identical.  
(Continued on page 35)

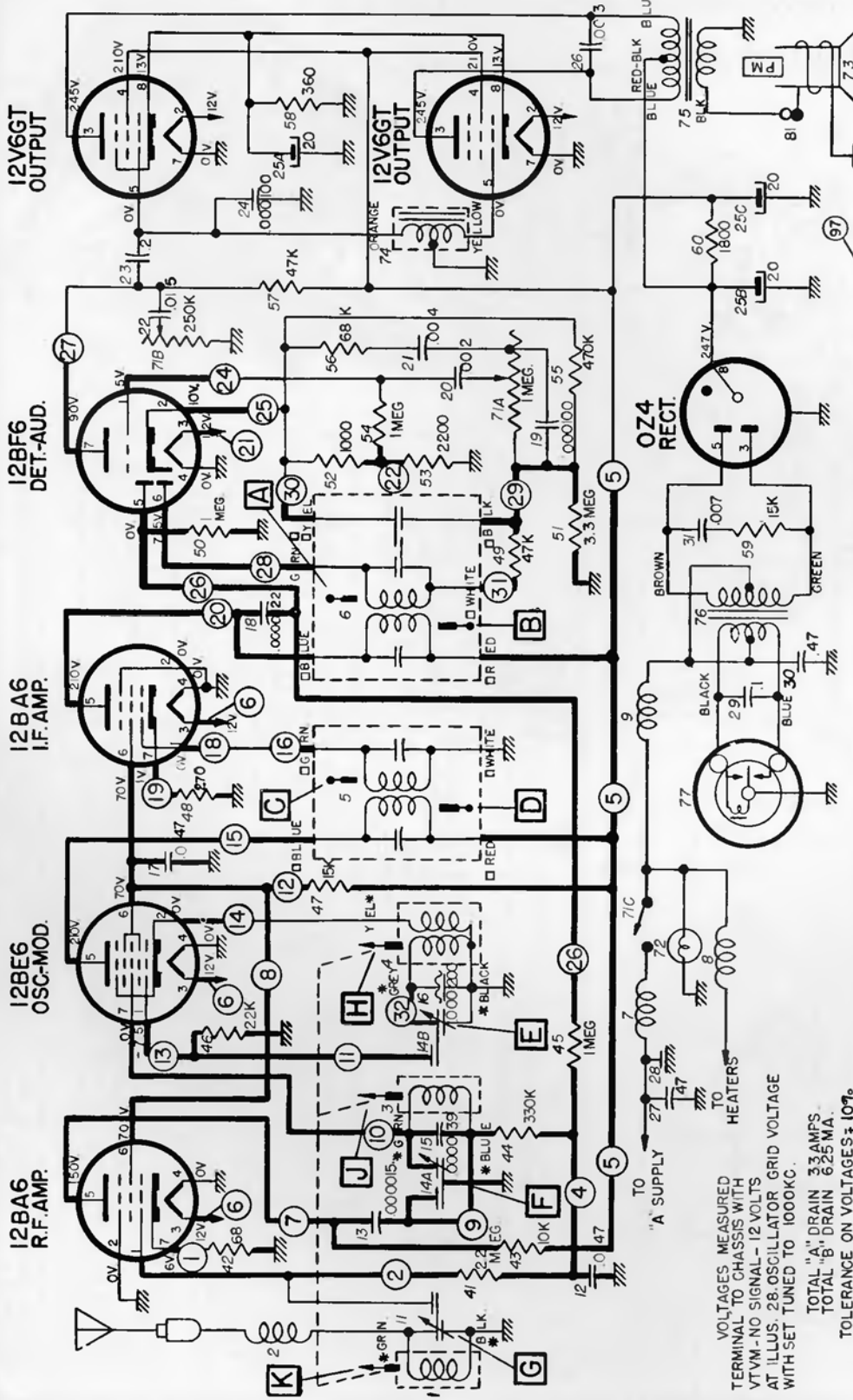

BUICK 981814—PRINTED CIRCUIT SHOWN IN HEAVY LINES

VOLTAGES MEASURED  
TERMINAL TO CHASSIS WITH  
VTVM—NO SIGNAL—12 VOLTS  
AT ILLUS. 28 OSCILLATOR GRID VOLTAGE  
WITH SET TUNED TO 1000KC.  
TOTAL "A" DRAIN 3.3 AMPS  
TOTAL "B" DRAIN 6.25 MA.  
TOLERANCE ON VOLTAGES ± 10%

□ COLORS OF TERMINAL ON SERVICE PARTS.  
\* COLOR OF TUNER LEADS.

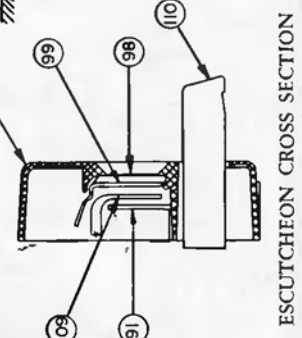

### PUSH BUTTON SET-UP PROCEDURE

Pull Push Button to the left and out. Tune in desired station manually. Push button all the way in.

(For alignment and other service information see page 35)

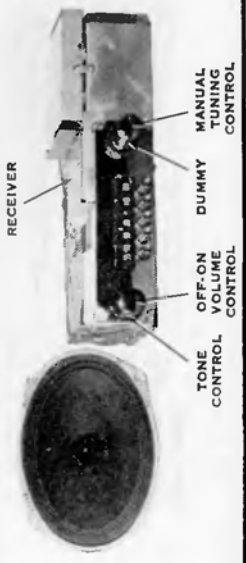

# DELCO

BUICK Model 981814 (Continued from page 34)  
 BUICK Model 981902 is practically identical.

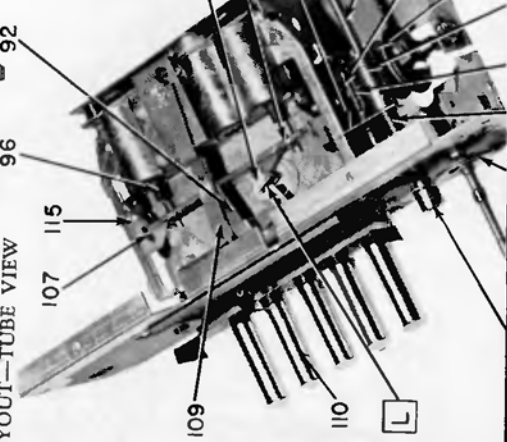
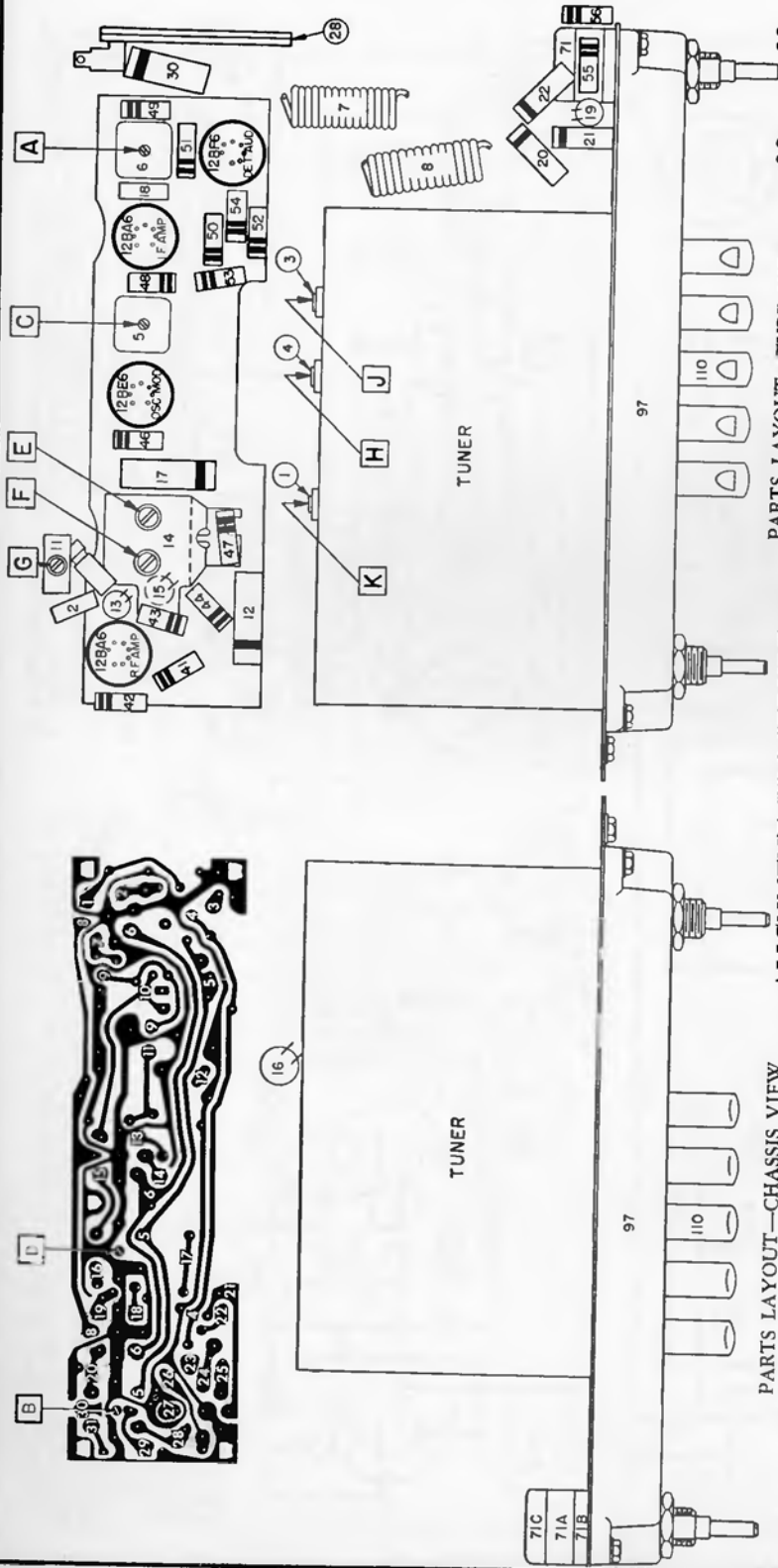

### ALIGNMENT PROCEDURE

Step	Series Condenser or Dummy Antenna	Connect Signal Generator To	Signal Generator Frequency	Tune Receiver to	Adjust in Sequence For Max. Output
1	0.1 Mfd.	12BE6 Grid (Pin #7)	262 KC	High Frequency Stop	A, B, C, D
2	.000082 Mfd.	Antenna Connector	1615 KC	High Frequency Stop	*E, F, G
3	.000082 Mfd.	Antenna Connector	600 KC	Signal Generator Signal	J, K
4	.000082 Mfd.	Antenna Connector	1615 KC	High Frequency Stop	F, G
5	.000082 Mfd.	Antenna Connector	600 KC	Signal Generator Signal	L**

\*Before making this adjustment check mechanical setting of oscillator core "H". The rear of the core should be 1/8" from the mounting end of the coil form. (This measurement is readily made by inserting a suitable plug in the mounting end of the coil form.) Core adjustment should be made with a non-metallic screwdriver, and core studs should be cemented in place with glyptal or household cement after alignment.

\*\*L is the pointer adjustment screw which is on the connecting link, between the pointer assembly and the parallel guide bar. It should be adjusted so that the dial pointer corresponds with the 600 KC mark on the dial.

With the radio installed and the car antenna plugged in, adjust the antenna trimmer "G" for maximum volume with the radio tuned to a weak station between 600 - 1000 KC (see sticker on case.)

101 116 106 104 103  
 102

# DELCO

BUICK WONDER BAR MODEL 981903

(Alignment is on page 37, adjacent at right)

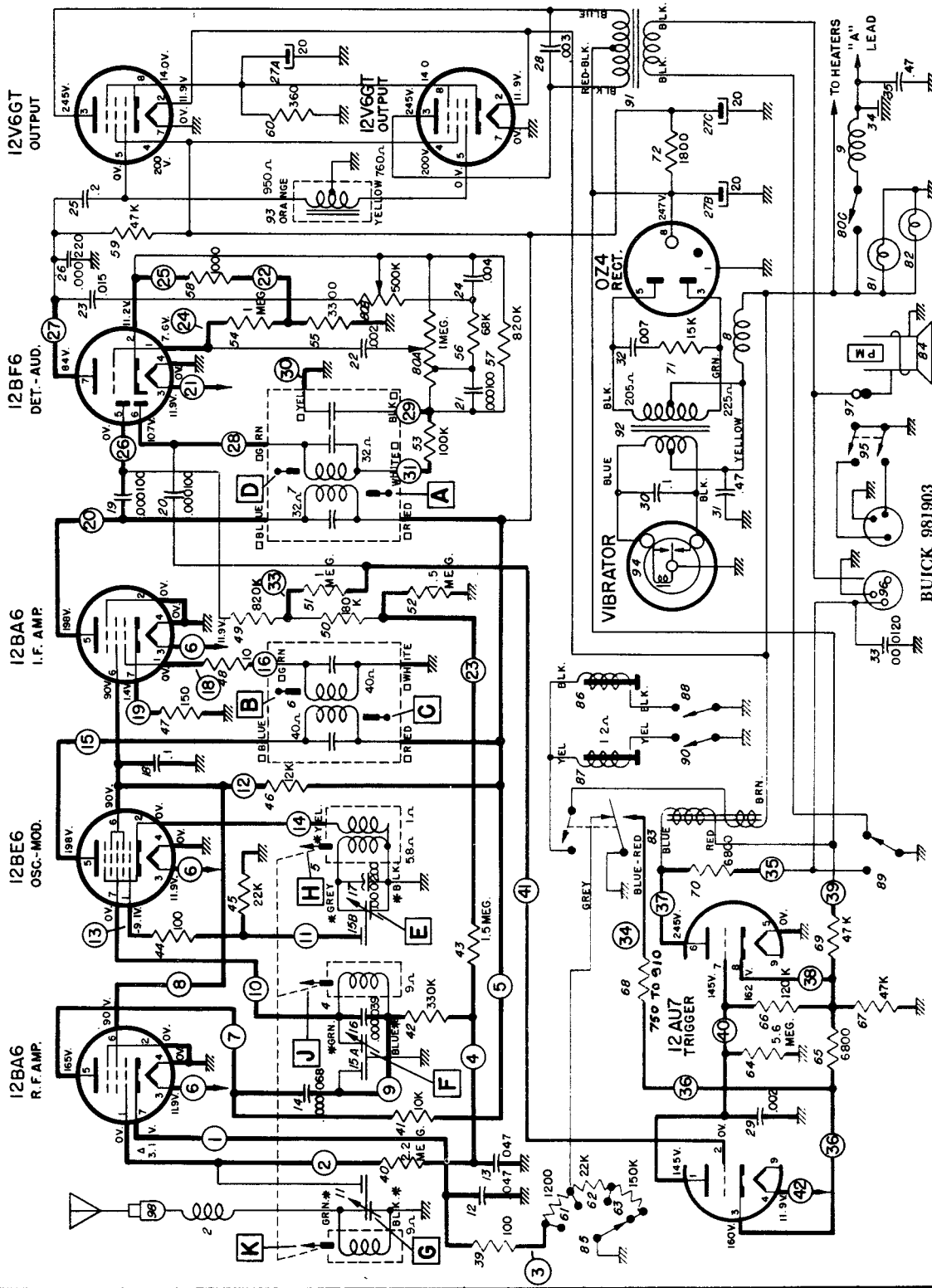

**SCHEMATIC DATA**

Voltages measured terminal to chassis with a VTVM - no signal and 12.0 volts at illus. 34 - tuner stopped. Oscillator grid voltage taken with set tuned to 1000 Kc.  
 Total "A" drain 3.3 Amps.  
 Total "B" drain 67 MA.  
 Tolerance on voltages ±10%.

**PRINTED CIRCUIT SHOWN IN HEAVY LINES**

□—Colors of terminal on service parts.  
 ○—Indicates lead from tuner coil assembly.  
 △—Voltage with sensitivity control in center position.  
 Resistances are ±20%. Values under 1 ohm are not shown.

BUICK 981903

# DELCO

BUICK Model 981903 Alignment, Continued

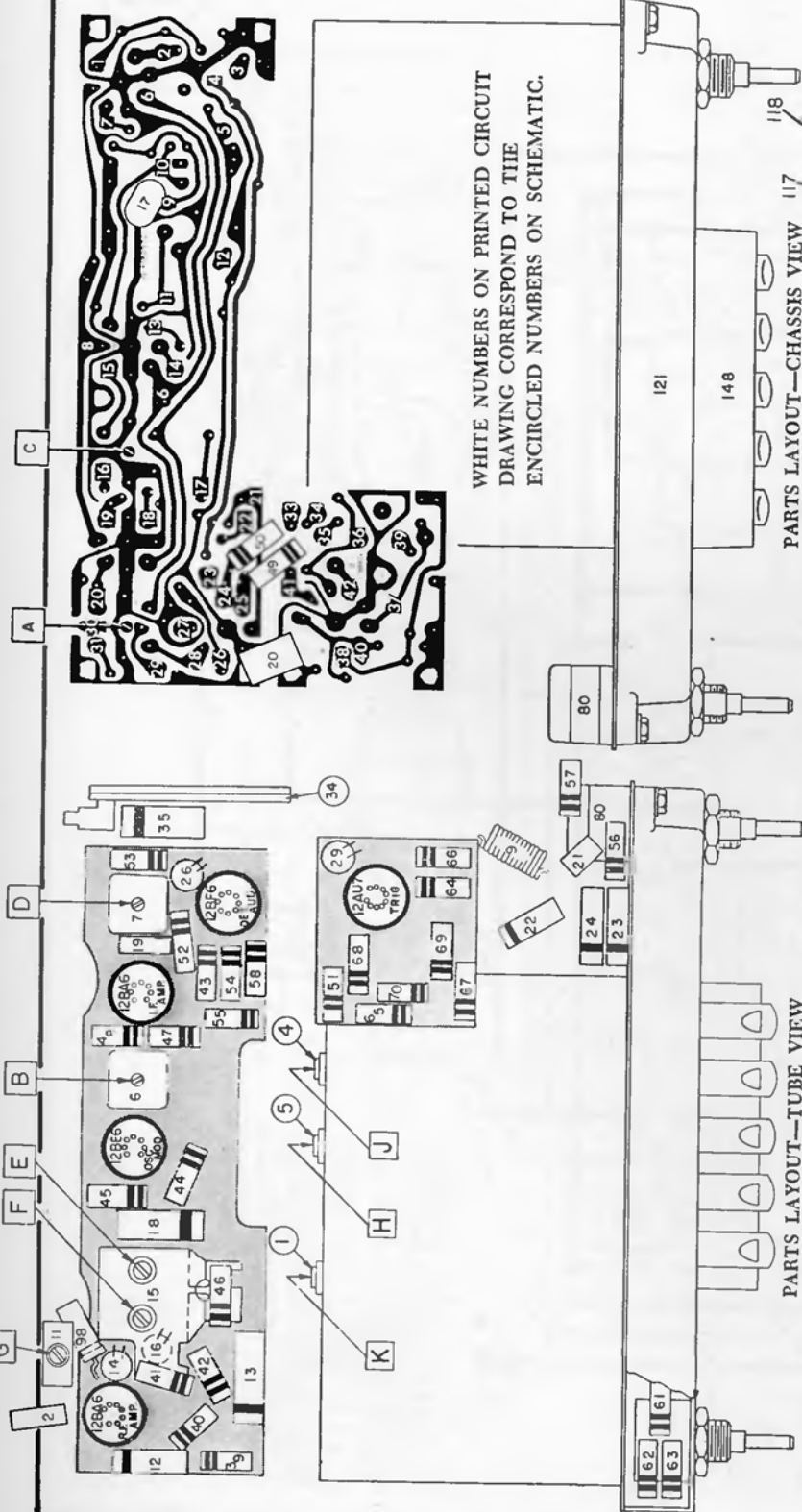

WHITE NUMBERS ON PRINTED CIRCUIT DRAWING CORRESPOND TO THE ENCIRCLED NUMBERS ON SCHEMATIC.

PARTS LAYOUT—TUBE VIEW

PARTS LAYOUT—CHASSIS VIEW

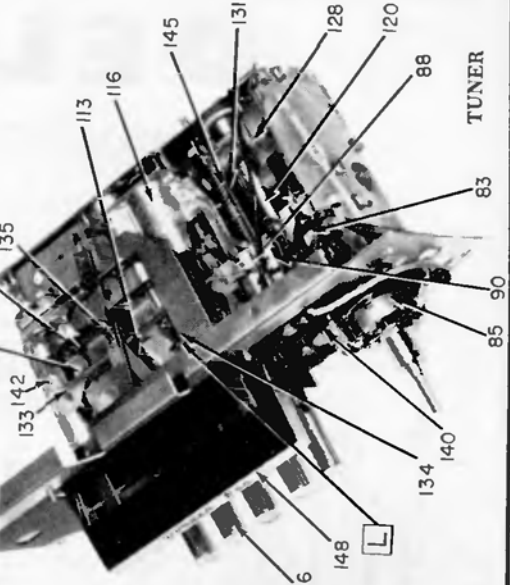

Step	Dummy Antenna	Signal Generator	Connect	Signal Generator Frequency	Tune Receiver To	Adjust in Sequence For Output Indicated
1	0.1 Mfd.	12BE6 Grid (Pin 7)		262 KC	•High Frequency Stop	A, B, C (Max.)
2	0.1 Mfd.	12BE6 Grid (Pin 7)		262 KC	High Frequency Stop	D (Min.)
3	.000082 Mfd.	Antenna Connector		1615 KC	High Frequency Stop	••E, F, G (Max.)
4	.000082 Mfd.	Antenna Connector		600 KC	Signal Generator Signal	J, K (Max.)
5	.000082 Mfd.	Antenna Connector		1615 KC	Signal Generator Signal	F, G (Max.)
6	.000082 Mfd.	Antenna Connector		1100 KC	Signal Generator Signal	•••L

•To tune to high frequency, put a .070" feeler gauge in slot against the high frequency stop, station selector bar and allow the treadle bar arm to run against the feeler gauge. Turn the radio off and then back on. This positions the tuner near the point where the treadle switch closes.

••Before making this adjustment, check the setting of oscillator core "H." The rear of the core should be 1 1/2" from the mounting end of the coil form. This measurement is readily made by inserting a suitable plug in the mounting end of the coil form. The core adjustment is made from the mounting end of the coil form with a non-metallic screw-driver.

•••"L" is the pointer adjustment screw on the end of the core guide bar—adjust so pointer reads 1100 KC. With the radio installed and the antenna plugged in, adjust the antenna trimmer "G" for maximum volume with the radio tuned to a weak station between 600 and 1000 KC (see sticker on case).

CONNECT A VTVM FROM AVC LINE (#4 ISLAND ON CIRCUIT BOARD) TO GROUND FOR OUTPUT INDICATIONS DURING ALIGNMENT.

# DELCO

PONTIAC MODEL 988671

(Alignment and other service material is on page 39)

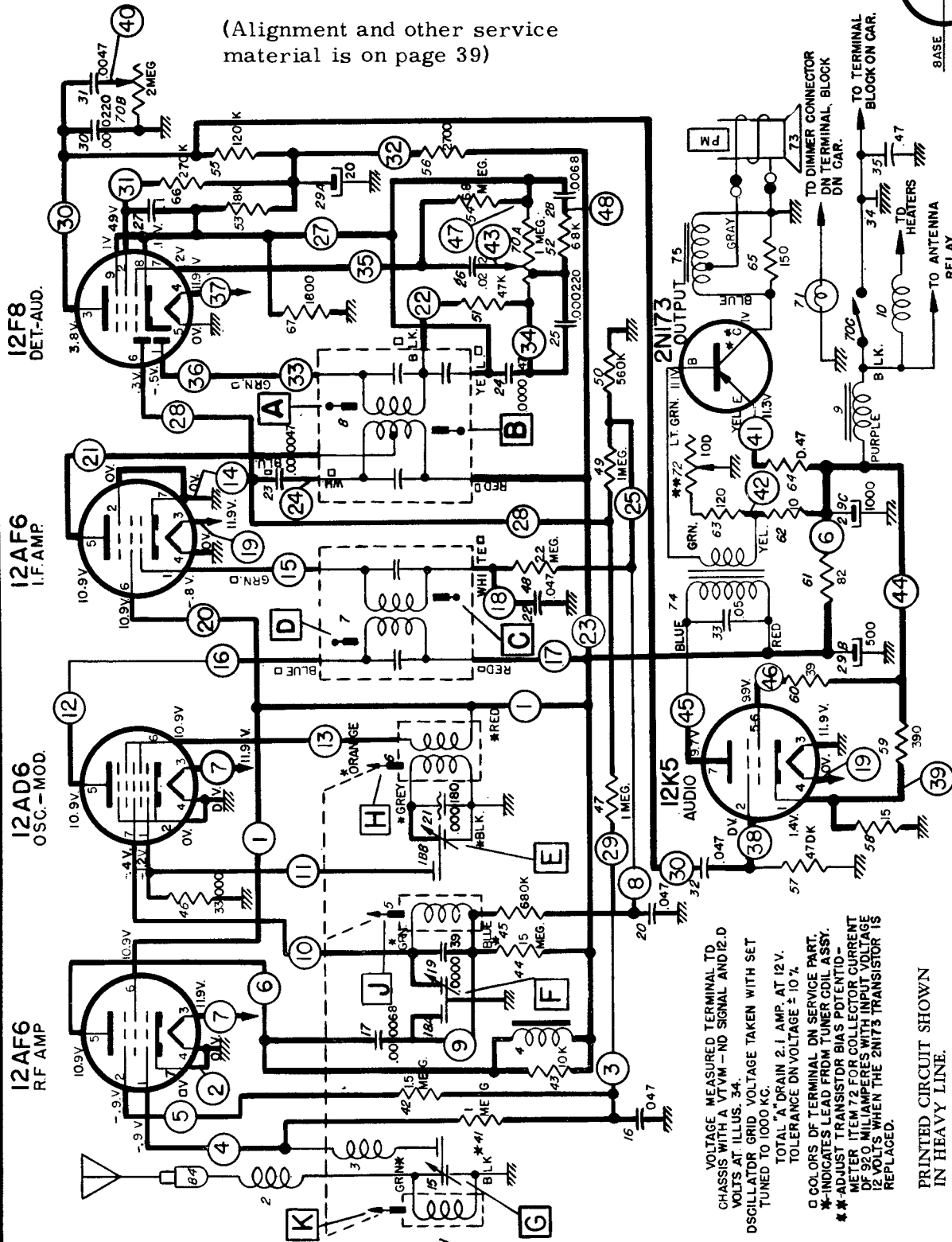
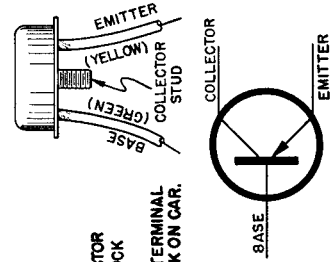

VOLTAGE MEASURED TERMINAL TO CHASSIS WITH A VTVM - NO SIGNAL AND 12.0 VOLTS AT ILLUS. 3A OSCILLATOR GRID VOLTAGE TAKEN WITH SET TUNED TO 1000 KC.

TOTAL "A" DRAIN 2.1 AMP. AT 12 V. TOLERANCE ON VOLTAGE ± 10%.

○ COLORS OF TERMINAL ON SERVICE PART.

\* INDICATES LEAD FROM TUNER COIL ASSY.

\*\* ADJUST TRANSISTOR BIAS POTENTIAL - METER ITEM 72 FOR COLLECTOR CURRENT OF 32.0 MILLIAMPERES WITH INPUT VOLTAGE OF 10 VOLTS WHEN THE 2N173 TRANSISTOR IS REPLACED.

PRINTED CIRCUIT SHOWN IN HEAVY LINE.

# DELCO

PONTIAC MODEL 988671

(Continued from page 38)

## TROUBLE SHOOTING THE OUTPUT STAGE

A quick way to determine that the 2N173 is conducting can be made by checking the collector voltage, from transistor case to the radio case. If no voltage is present the transistor is not conducting or the transistor heat radiator is grounded to the radio case. If the voltage at the collector is higher than listed the transistor is conducting too heavily (check with milliammeter) or the output transformer is open. The amount of current the transistor conducts is determined by the voltages at each element, the resistor in the base and emitter circuits, the input transformer secondary resistance, and the transistor itself.

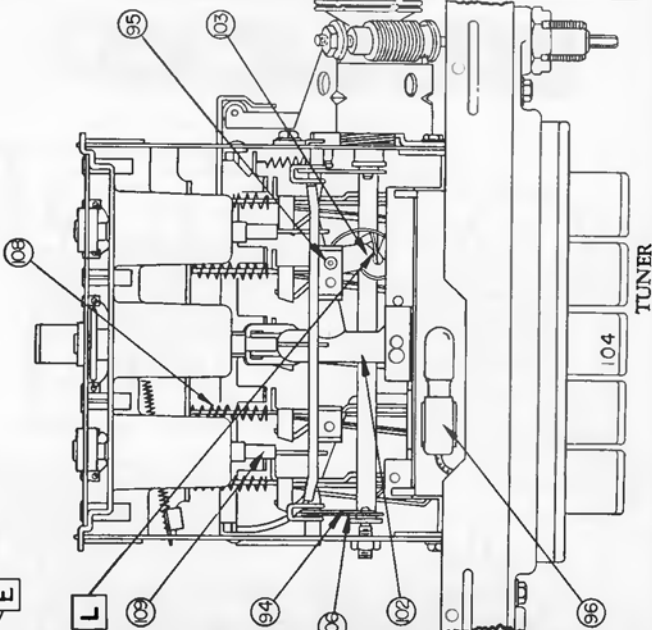
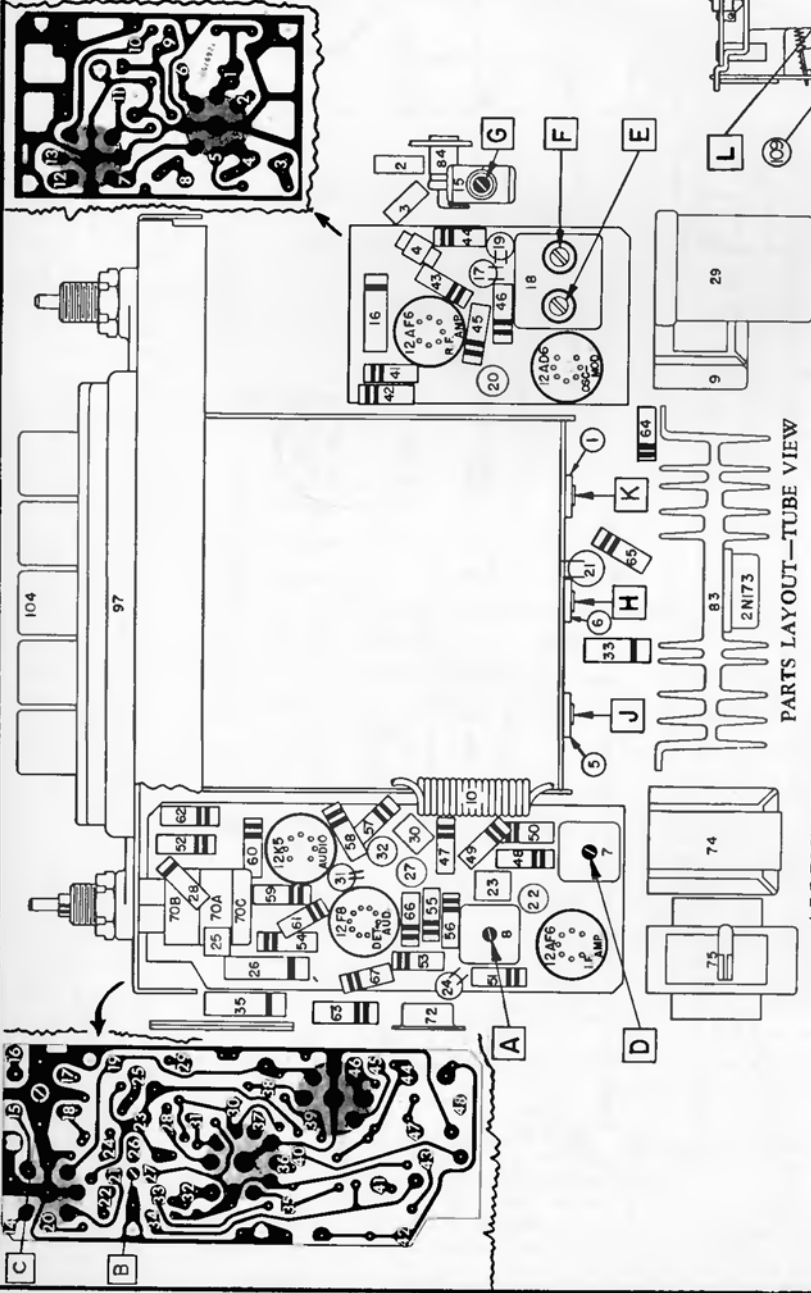

### ALIGNMENT PROCEDURE:

Steps	Series Capacitor or Dummy Antenna	Connect to	Signal Generator Frequency	Tune Receiver to	Adjust in Sequence For Max. Output
1	0.1 Mfd.	12BE6 Grid (Pin #7)	262 KC	High Frequency Stop	A, B, C, D
2	0.000047 Mfd.	Antenna Connector	1615 KC	High Frequency Stop	*E, F, G
3	0.000047 Mfd.	Antenna Connector	600 KC	Signal Generator Signal	J, K
4	0.000047 Mfd.	Antenna Connector	1615 KC	High Frequency Stop	F, G
5	0.000047 Mfd.	Antenna Connector	1000 KC	Signal Generator Signal	**L

\*Before making this adjustment check the mechanical setting of the oscillator core "H". The slotted end of core should be 1/8" from the mounting end of the coil form. (This measurement is readily made by inserting a suitable plug in the mounting end of the coil form.) Core adjustment should be made with a non-metallic screwdriver.

\*\*"L" is the pointer adjusting screw which is on the pointer connecting link (see tuner drawing) and should be adjusted so the pointer reads 1000 KC.

With the radio installed and the car antenna plugged in adjust the antenna trimmer "G" for maximum volume with the radio tuned to a weak station between 600 and 1000 KC. (See sticker on case.)

# DELCO

12V PONTIAC MODEL 988672

(Alignment and other material on page 41)

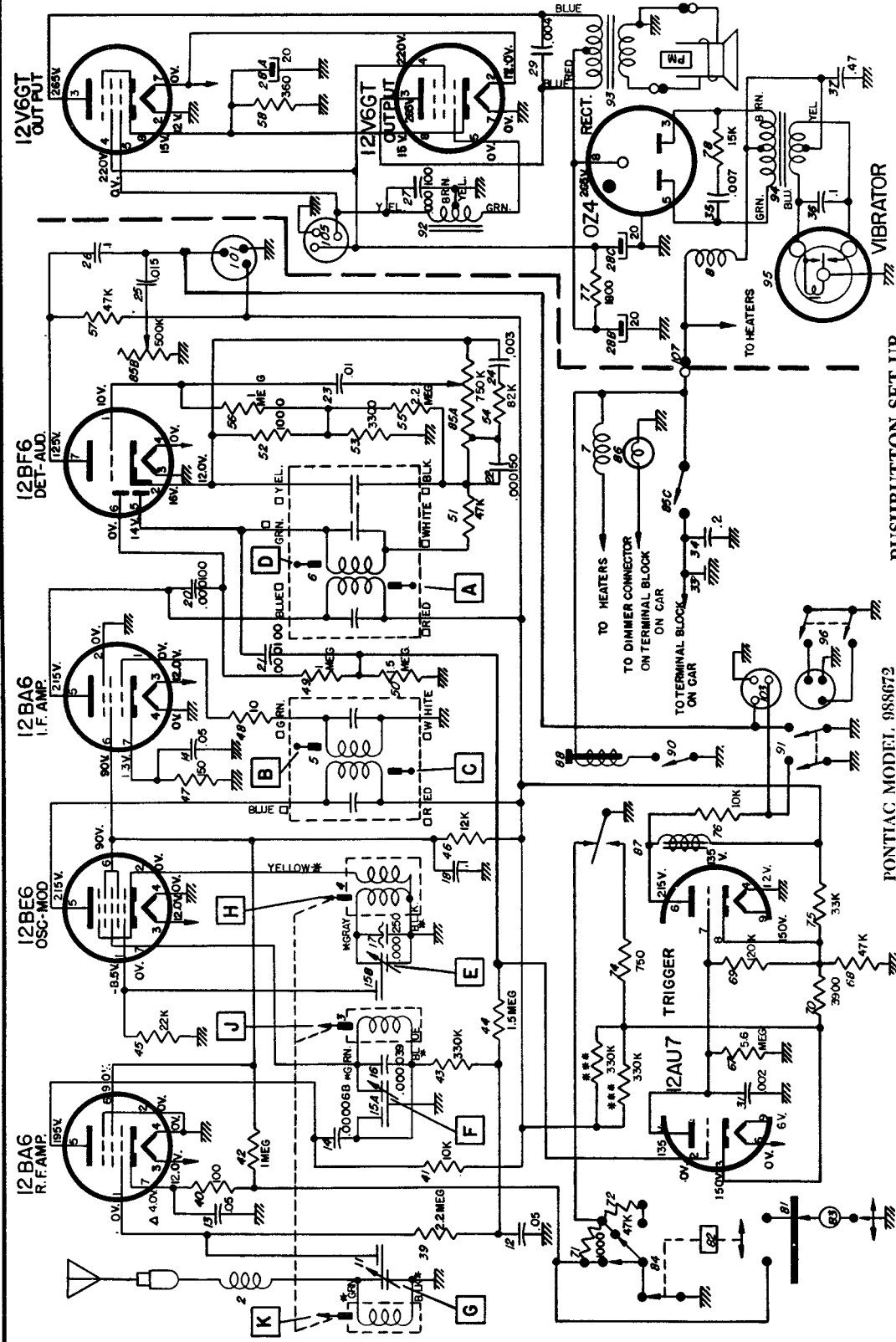

**PUSHBUTTON SET-UP**

1. Open the hinged door below the dial exposing the selector tabs.
2. Tune in the desired signal nearest the left end of the dial.
3. Move the first selector tab (one farthest left) until it lines up with the pointer tip.
4. Repeat set-up steps 2 and 3 for the remaining selector tabs, choosing stations from left to right on the dial.

Voltages measured terminal to chassis with a VTVM — No signal and 12.0 volts at Illus. 33.  
 —Tuner stopped. Oscillator grid voltage taken with set tuned to 1000 KC.  
 Total "A" Drain 3.3 Amps. Total "B" Drain 67 MA.  
 \*—Indicates Lead from Tuner Coil Assy.  
 \*\*\*—Either or Both Resistors May Not Be Found on All Sets.



AUDIO—POWER SUPPLY UNIT

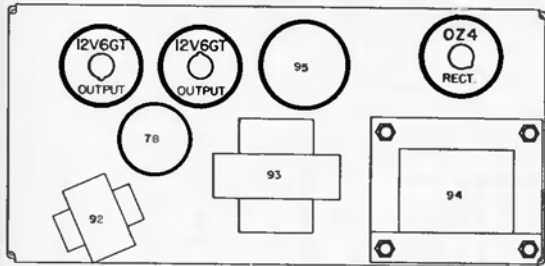

PARTS LAYOUT — TUBE VIEW

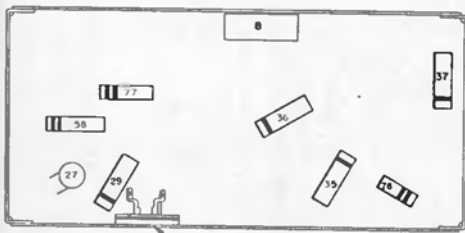

PARTS LAYOUT — CHASSIS VIEW

RF—UNIT

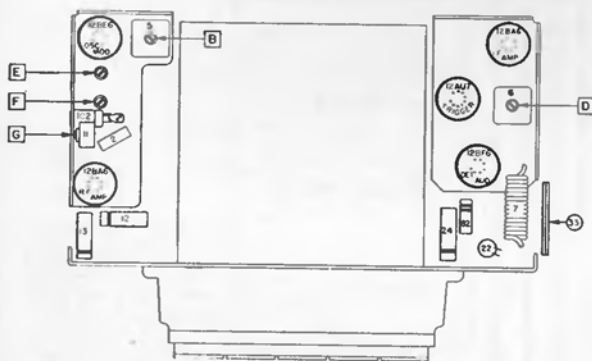

PARTS LAYOUT — TUBE VIEW

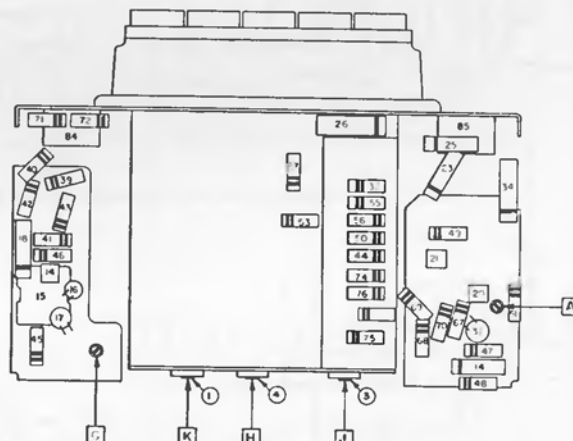

PARTS LAYOUT — CHASSIS VIEW

# DELCO

PONTIAC Model 988672  
(Continued)

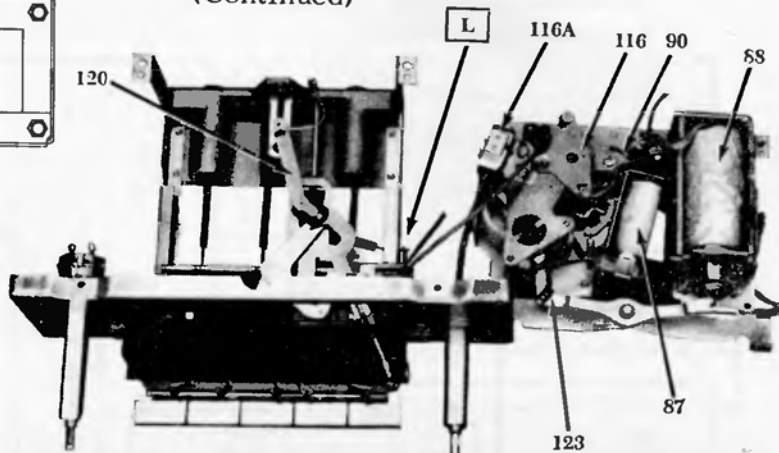

TUNER UNFOLDED

**SIGNAL SEEKING TUNER ALIGNMENT PROCEDURE:**

Output Meter Connection \_\_\_\_\_ VTCM From AVC Line To Chassis (see Parts layout )  
Generator Return \_\_\_\_\_ Receiver Chassis

Step	Dummy Antenna	Connect To	Signal Generator Frequency	Tune Receiver To	Adjust in Sequence
1	0.1 Mfd.	12BE6 Grid (Pin 7)	262 KC	*High Frequency Stop	A, B, C (Max.)
2	0.1 Mfd.	12BE6 Grid (Pin 7)	262 KC	High Frequency Stop	D (Min.)
3	.000068 Mfd.	Antenna Connector	1615 KC	High Frequency Stop	**E, F, G (Max.)
4	.000068 Mfd.	Antenna Connector	600 KC	Signal Generator Signal	J, K (Max.)
5	.000068 Mfd.	Antenna Connector	1615 KC	Signal Generator Signal	F, G (Max.)
6	.000068 Mfd.	Antenna Connector	1100 KC	Signal Generator Signal	***L

\*To tune to high frequency, put a 0.070" feeler gauge (or bare #13 wire) in slot against the high frequency stop. (See tuner pictures). Turn manual control to allow the planetary arm to run against the feeler gauge.

\*\*Before making this adjustment, check the setting of oscillator core "H." The rear of the core should be 1 3/8" from the mounting end of the coil form. This measurement is readily made by inserting a suitable plug in the mounting end of the coil form. The core adjustment is made from the mounting end of the coil form with an insulated screw driver. (It will be necessary to steady the core guide bar by applying a downward pressure at the antenna core end of the bar while making these adjustments.) If this adjustment is necessary, first dissolve the glyptal seal on the core stud and be sure to reseal after making the adjustment.

\*\*\*"L" is the pointer adjustment screw on the end of the core guide bar—adjust so pointer reads 1100 KC.

With the radio installed and the antenna plugged in, adjust the antenna trimmer "G" for maximum volume with the radio tuned to a weak station between 600 and 1000 KC (see sticker on case).

DELCO

PONTIAC Model 988823 (Continued on page 43)  
 CHEVROLET Model 987730, CORVETTE #3748611,  
 OLDSMOBILE 989129 are similar.

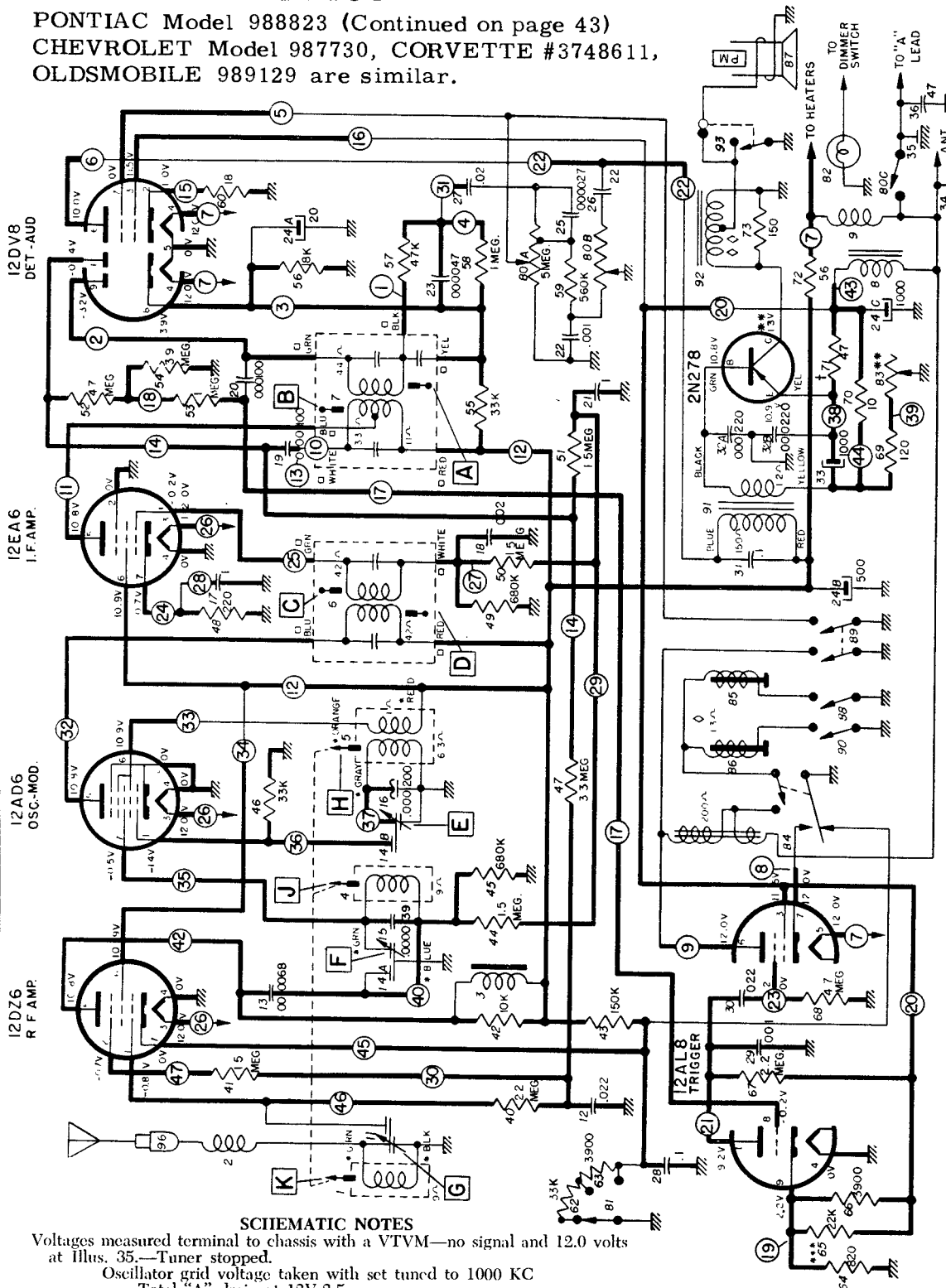

**SCHEMATIC NOTES**

- Voltages measured terminal to chassis with a VTVM—no signal and 12.0 volts at illus. 35.—Tuner stopped.
- Oscillator grid voltage taken with set tuned to 1000 KC
- Total "A" drain at 12V-2.5 amperes
- Tolerance on all voltage  $\pm 10\%$
- Colors of terminals on service part.
- Indicates lead from tuner coil assembly.
- Before measuring transistor voltages, the shorting-type speaker socket must be opened and a 4 ohm speaker connected. If transistor is replaced, adjust bias potentiometer (Illus. 83) to obtain proper collector voltage with 12 volts input to radio.
- Does not appear on all radios.

PONTIAC MODEL 988823  
 PRINTED CIRCUIT SHOWN IN HEAVY LINES

†—illus. 71 is a fuse resistor for the transistor. Value is .36 ohms at room temperature.

WHEN RADIO IS OPERATED ON BATTERY ELIMINATOR, THE  
 TUNER MAY STOP SEEKING EVERY TIME A SOLENOID ENER-  
 GIZES, DUE TO VOLTAGE REGULATION.

Speaker socket, illus. 93, is a shorting type to prevent transistor damage if speaker is disconnected. If not opened, radio will be very weak or dead.

**PUSHBUTTON SETUP PROCEDURE**

1. Pull button to the left and out.
2. Tune in desired station manually.
3. Push button all the way in.

# DELCO

PONTIAC Model 988823 (Continued)  
 CHEVROLET 987730, CORVETTE 3748611,  
 and OLDSMOBILE Model 989129  
 are similar.

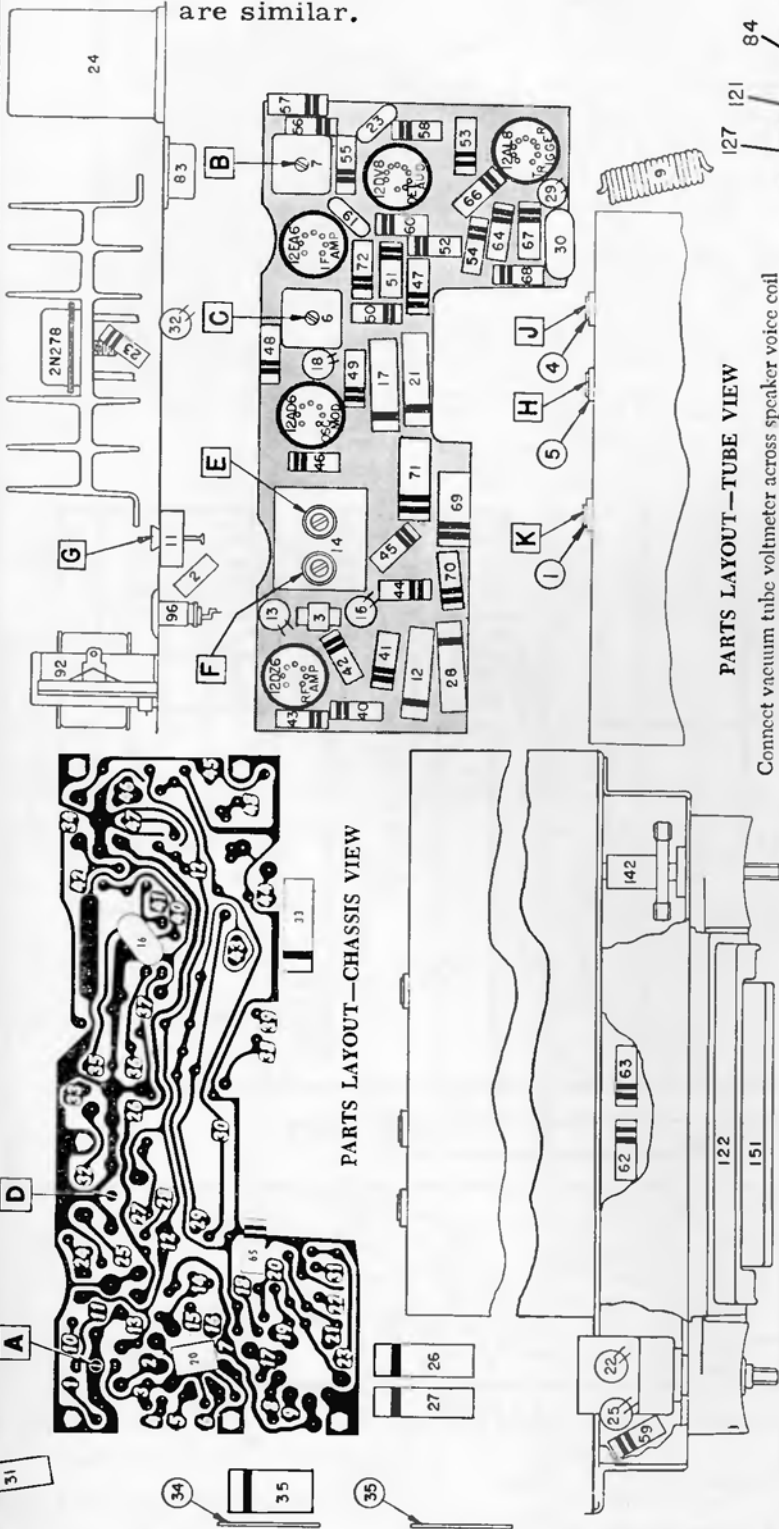

PARTS LAYOUT—TUBE VIEW

Connect vacuum tube voltmeter across speaker voice coil during alignment.

Step	Dummy Antenna	Connect To	Signal Generator Frequency	Tune Receiver To	Adjust in Sequence
1	0.1 Mfd.	12AD6 Grid (Pin 7)	262 KC	• High Frequency Stop	A, D, B, C (Max.)
2	.000068 Mfd.	Antenna Connector	1615 KC	High Frequency Stop	•• E, F, G (Max.)
3	.000068 Mfd.	Antenna Connector	600 KC	Signal Generator Signal	J, K (Max.)
4	.000068 Mfd.	Antenna Connector	1400 KC	Signal Generator Signal	F, G (Max.)
5	.000068 Mfd.	Antenna Connector	1100 KC	Signal Generator Signal	••• L

•To tune to high frequency, put a .070" feeler gauge in slot against the high frequency stop, manual control to allow the treadle bar arm to run against the feeler gauge. This sets the dial near the point where the treadle solenoid switch closes.

••Before making this adjustment, check the setting of oscillator core "H." The rear of the core should be 1 5/8" from the mounting end of the coil form. This measurement is readily made by inserting a suitable plug in the mounting end of the coil form. The core adjustment is made from the mounting end of the coil form with a non-metallic screw driver.

•••"L" is the pointer adjustment which is on the connecting link, between the pointer assembly and core guide bar—adjust so pointer reads 1100 KC.

With the radio installed and the antenna plugged in, adjust the antenna trimmer "G" for maximum volume with the radio tuned to a weak station between 600 and 1000 KC (see sticker on case).

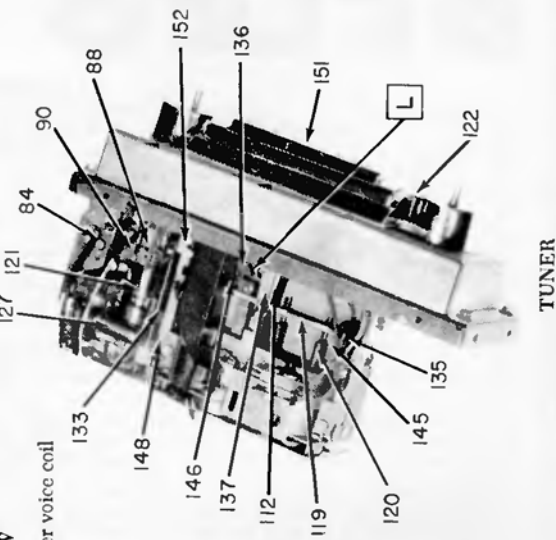

TUNER

WHITE NUMBERS ON PRINTED CIRCUIT BOARD DRAWING CORRESPOND TO NUMBERS ENCIRCLED ON SCHEMATIC.

# DELCO

PONTIAC DELUXE MODEL 988822

(Continued on page 45 adjacent at right)

### ALIGNMENT PROCEDURE

Steps	Series Capacitor or Dummy Antenna	Connect Signal Generator to	Signal Generator Frequency	Tune Receiver to	Adjust in Sequence For Max. Output
1	0.1 Mfd.	12AD6 Grid (Pin #7)	262 KC	High Frequency Stop	A, B, C, D
2	0.000068 Mfd.	Antenna Connector	1615 KC	High Frequency Stop	*E, F, G
3	0.000068 Mfd.	Antenna Connector	600 KC	Signal Generator Signal	J, K
4	0.000068 Mfd.	Antenna Connector	1615 KC	High Frequency Stop	F, G
5	0.000068 Mfd.	Antenna Connector	1100 KC	Signal Generator Signal	L**

\*Before making this adjustment check mechanical setting of oscillator core "H." The rear of the core should be  $1\frac{1}{8}$ " from the mounting end of the coil form. (This measurement is readily made by inserting a suitable plug in the mounting end of the coil form.) Core adjustment should be made with a non-metallic screw driver.

\*\*L is the pointer adjustment which is on the connecting link, between the pointer assembly and core guide bar (See tuner Dwg.). It should be adjusted so that when looking directly at the dial the pointer is on the 1100 KC mark. This setting is to give the correct relationship between the pointer and the dial when the radio is installed in a car.

With the radio installed and the car antenna plugged in adjust the antenna trimmer "G" for maximum volume with the radio tuned to a weak station between 600 and 1000 KC (see sticker on case.)

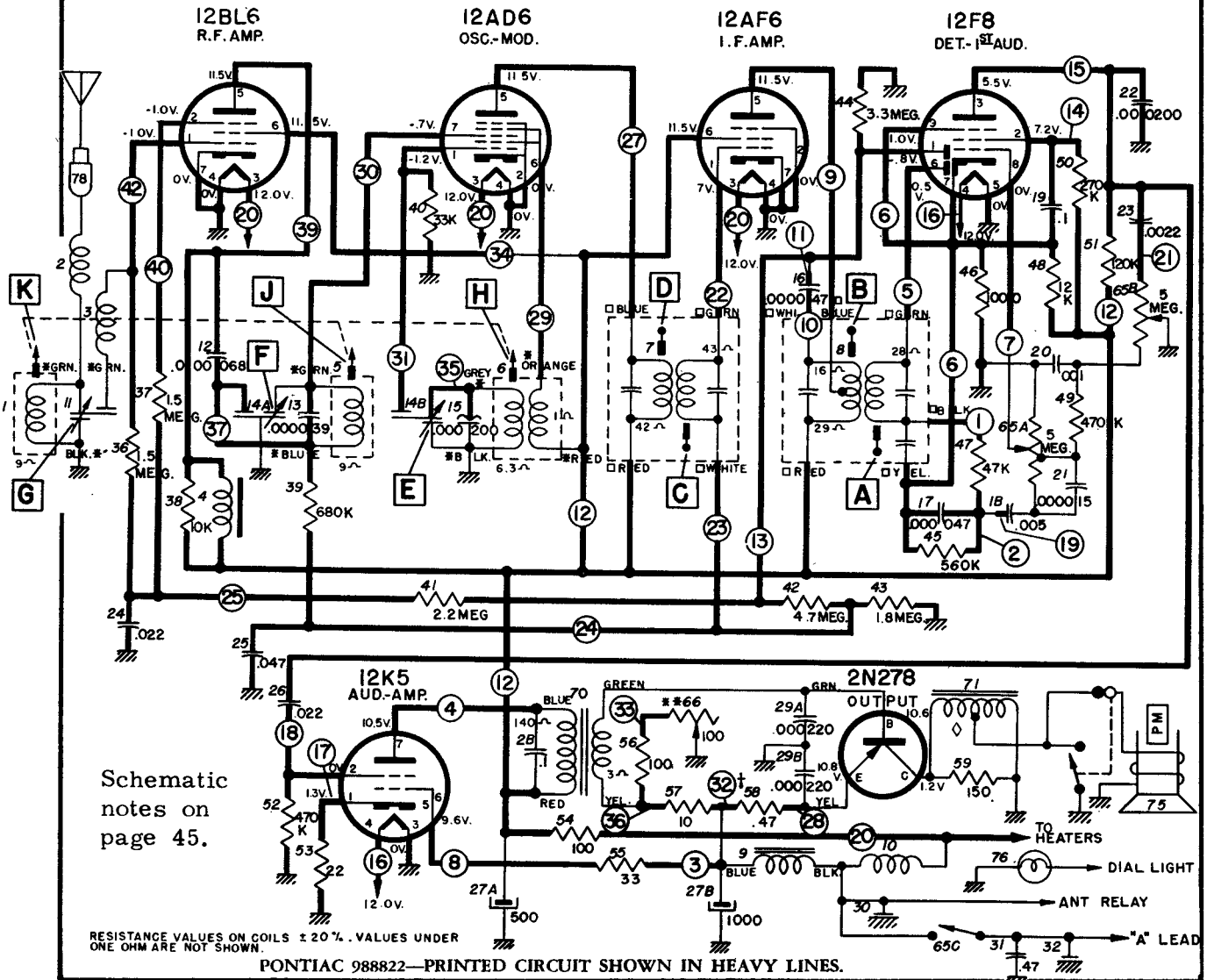

Schematic notes on page 45.

RESISTANCE VALUES ON COILS ± 20%. VALUES UNDER ONE OHM ARE NOT SHOWN.

PONTIAC 988822—PRINTED CIRCUIT SHOWN IN HEAVY LINES.

DELCO PONTIAC Model 988822, Continued from page 44

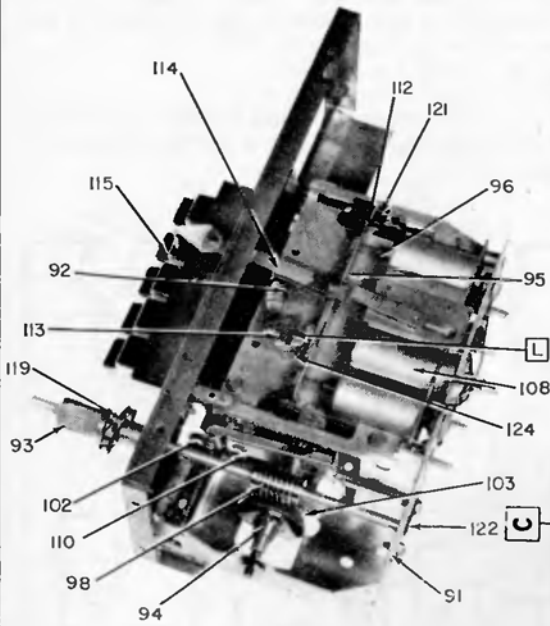

TUNER

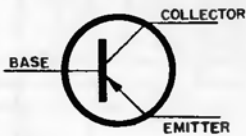
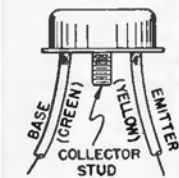

- ♦♦ - ADJUST TRANSISTOR BIAS POTENTIOMETER TO CHASSIS WITH A VTVM - NO SIGNAL AND 12.0 VOLTS AT ILLUS. 32
- † - OSCILLATOR GRID VOLTAGE TAKEN WITH SET TUNED TO 1000 KC
- - TOTAL A. DRAIN AT 12V - 2.2 AMPS TOLERANCE ON VOLTAGES ±10%
- - COLORS OF TERMINAL ON SERVICE PARTS SOCKET IS NOT HELD OPEN, NORMAL RESISTANCE IS 1-2 OHMS.

CONNECT VACUUM TUBE VOLTMETER ACROSS SPEAKER VOICE COIL DURING ALIGNMENT.  
NUMBERS ON PRINTED CIRCUIT BOARD CORRESPOND WITH NUMBERS IN CIRCLES ON SCHEMATIC DIAGRAM.

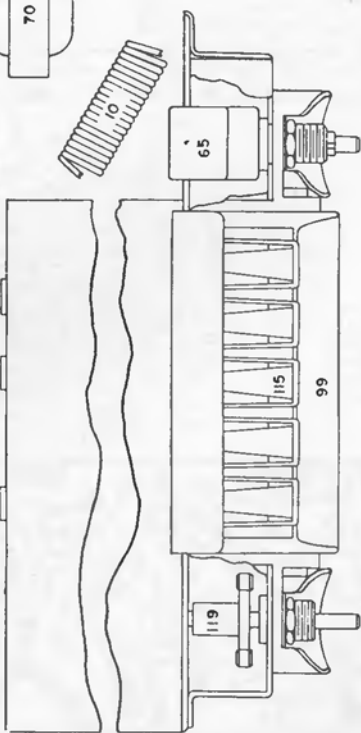
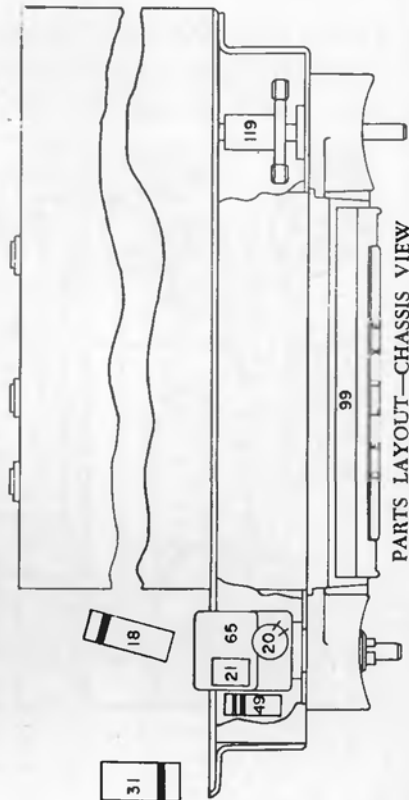
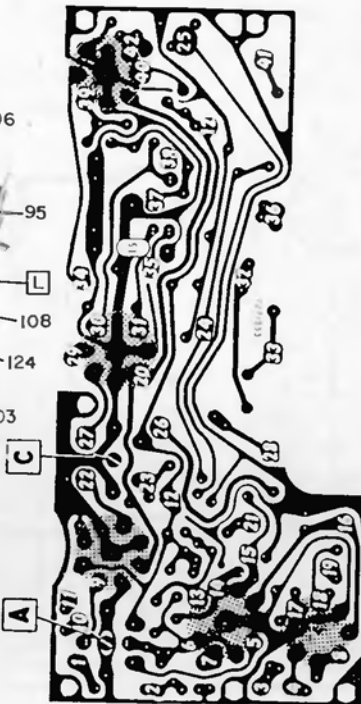

# DELCO

PONTIAC RADIO MODEL 988837

OLDSMOBILE Model 989131 is similar.

(Continued on page 47, at right)

**SCHEMATIC DATA**

Voltages measured terminal to chassis with a VTVM—no signal. The portable unit voltages are taken with a battery voltage of 5.3 volts. Rack unit voltages taken with 12 volts at Illus. 46. Oscillator Base voltage taken with set tuned to 1000 Kc.

Total "A" Drain in Car 1.3 amps.

Total "A" Drain of Portable 7.6 ma.

Resistances are  $\pm 20\%$ . Ohmmeter reading in transistor circuits are affected by meter battery polarity. Check in both directions and use highest reading.

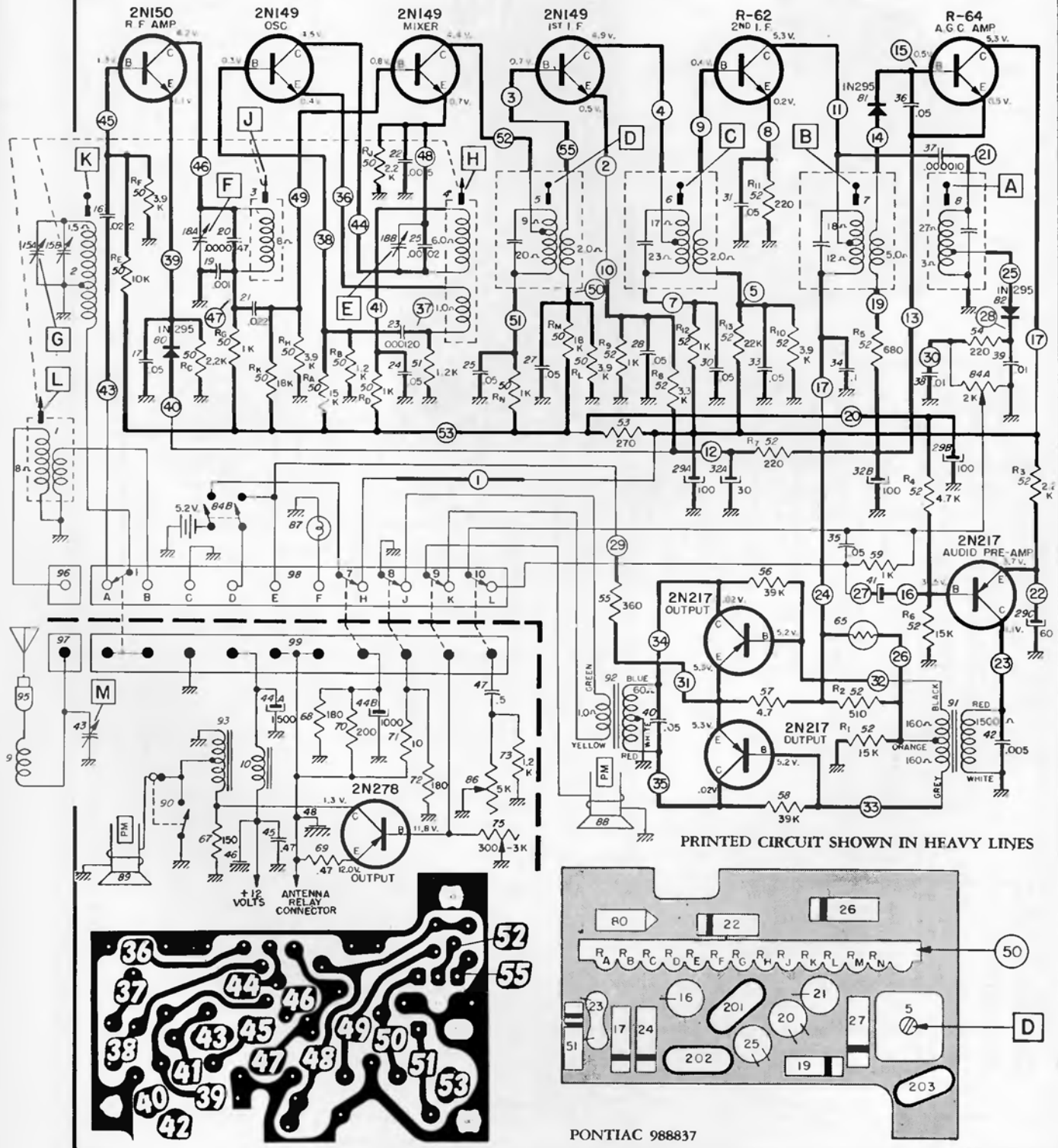

PRINTED CIRCUIT SHOWN IN HEAVY LINES

PONTIAC 988837

# DELCO

PONTIAC Radio Model 988837,  
OLDSMOBILE 989131 very similar.  
(Continued from page 46, at left)

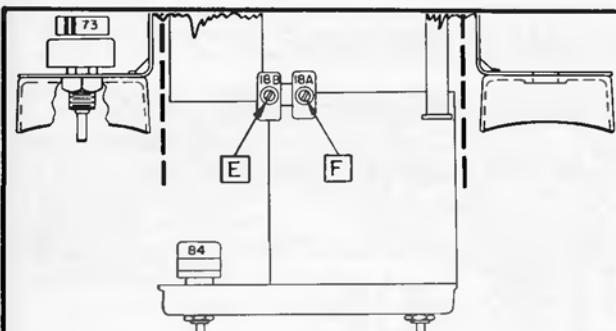

PARTS LAYOUT—TOP VIEW

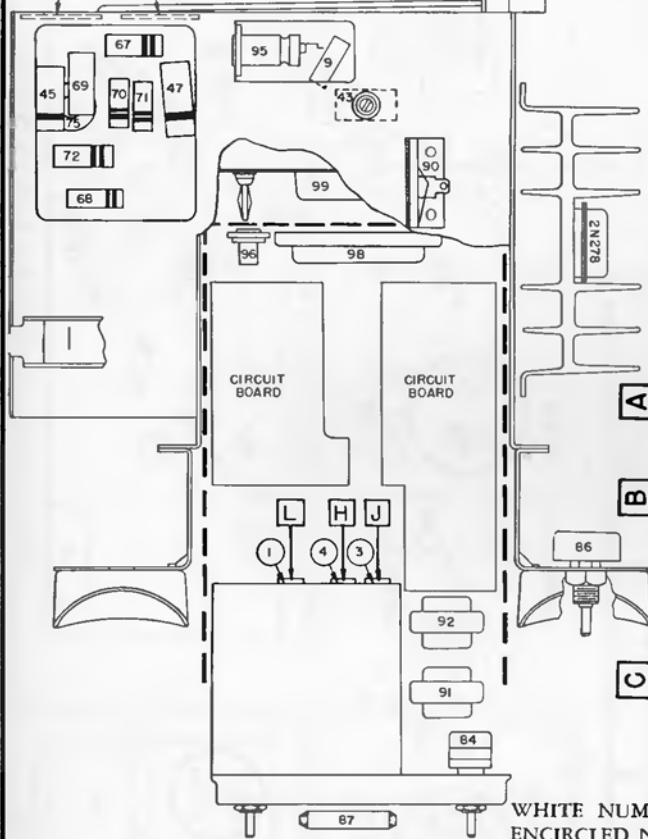

CIRCUIT BOARD

CIRCUIT BOARD

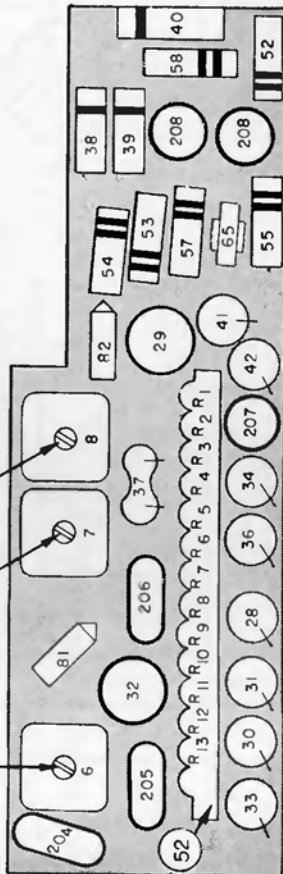

WHITE NUMBERS ON PRINTED CIRCUIT DRAWINGS CORRESPOND TO ENCIRCLED NUMBERS ON SCHEMATIC DIAGRAM.

**ALIGNMENT PROCEDURE:**

PARTS LAYOUT—BOTTOM VIEW

STEP	DUMMY ANTENNA (METHOD OF CONNECTING GENERATOR)	CONNECT GENERATOR TO	SIGNAL FREQUENCY	TUNE RECEIVER TO	ADJUST IN SEQUENCE FOR MAX. OUTPUT
1	0.1 Mfd. Cap.	Mixer 2N149 Base (Island #49)	262 KC.	High Frequency Stop	A, B, C, D*
2	Pick Up Loop	By Induction to Antenna	1615 KC.	High Frequency Stop	E, F, G**
3	Pick Up Loop	By Induction to Antenna	1000 KC.	Signal Generator Frequency	J
4	Pick Up Loop	By Induction to Antenna	1615 KC.	High Frequency Stop	F
5	Pick Up Loop	By Induction to Antenna	600 KC.	Signal Generator Frequency	K***
6	Pick Up Loop	By Induction to Antenna	1400 KC.	Signal Generator Frequency	G††
7	Pick Up Loop	By Induction to Antenna	1100 KC.	Signal Generator Frequency	P†
8	.000068 Mfd.	Antenna Connector	1000 KC.	Signal Generator Frequency	L†††
9	With portable unit plug into the car unit, adjust the antenna trimmer M in the rack for maximum volume with the radio tuned to a weak station between 600 and 1000 KC.				

\*I, F, cores originally in radio are cemented in position and cannot be aligned. Replacement parts should be aligned with a non-metallic tool.

\*\*Before making these adjustments, check mechanical setting of three tuner cores H, J, and L. The rear of the cores should be 1-11/32" from the back of the coil form.

\*\*\*Adjustment is made by changing antenna coil position on core.

†Adjust pointer to read 11 on dial.

††Trimmer on gang capacitor.

†††This step is needed only when antenna coil or core is replaced. The portable unit must be in the rack and the cover on portable and cover on rack must be removed to make this adjustment.

# DELCO

## OLDSMOBILE DELUXE MODEL 989001

(Continued on page 49 adjacent at right)

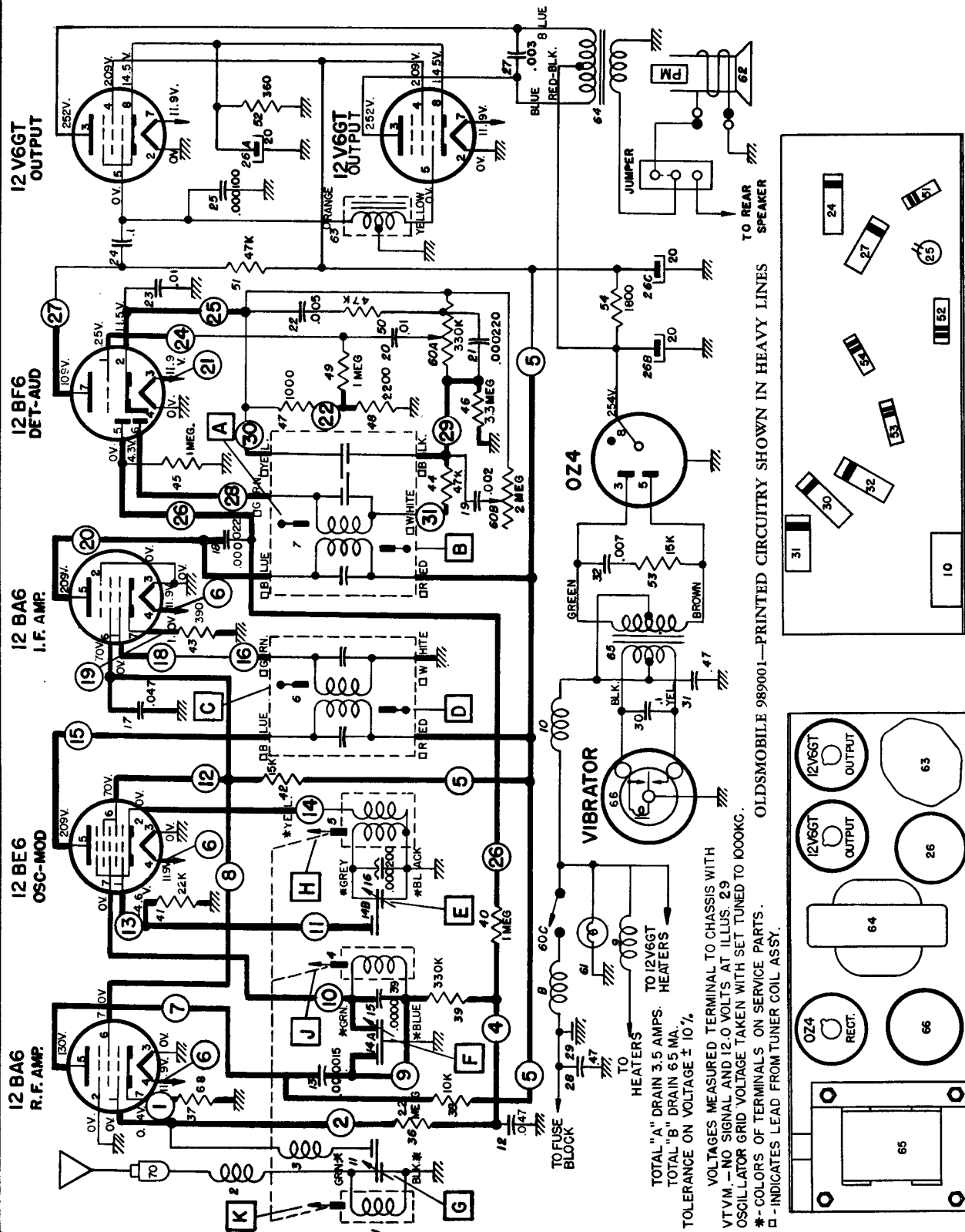



# DELCO

OLDSMOBILE Model 989001  
(Continued from page 48)

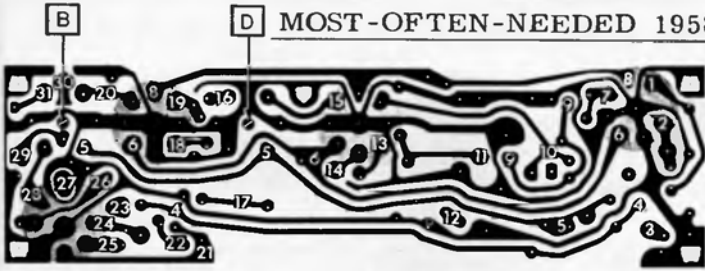

WHITE NUMBERS ON PRINTED CIRCUIT BOARD DRAWING CORRESPOND TO NUMBERS ENCIRCLED ON SCHEMATIC.

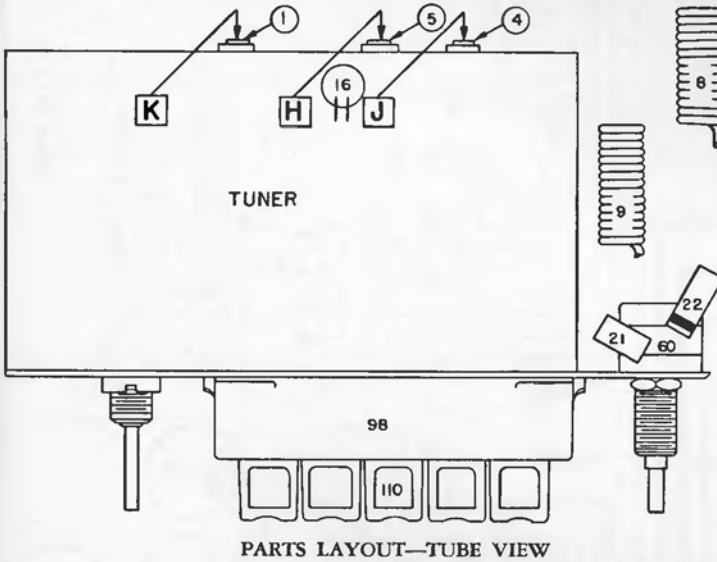
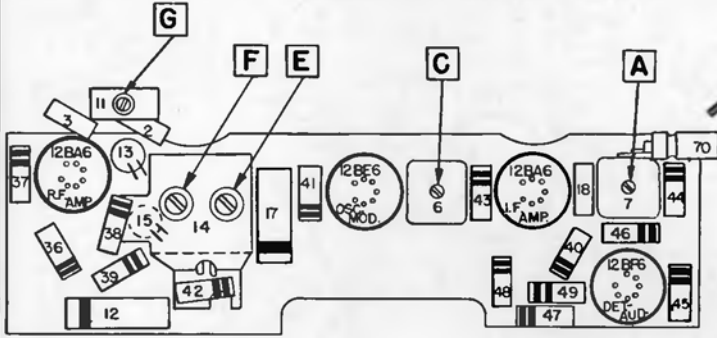

PARTS LAYOUT—TUBE VIEW

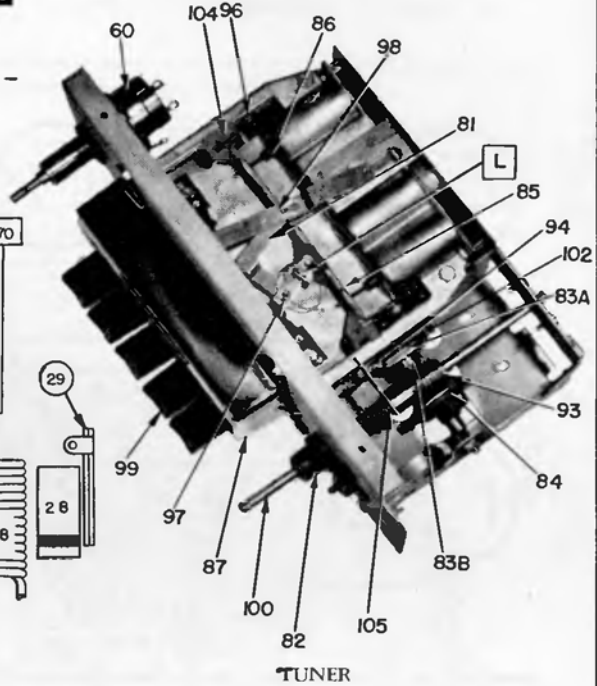

### PUSH BUTTON SETUP PROCEDURE

Pull Push Button to the left and out. Tune in desired station manually. Push button all the way in.

### ALIGNMENT PROCEDURE

- Output Meter Connections.....Across Voice Coil
- Generator Return.....To Receiver Chassis
- Dummy Antenna.....In Series With Generator
- Volume Control Position.....Maximum Volume
- Tone Control Position.....Treble Position
- Generator Output.....Minimum for Readable Indication

Steps	Series Capacitor or Dummy Antenna	Connect Signal Generator to	Signal Generator Frequency	Tune Receiver to	Adjust in Sequence For Max. Output
1	0.1 Mfd.	12BE6 Grid (Pin #7)	262 KC	High Frequency Stop	A, B, C, D
2	0.000068 Mfd.	Antenna Connector	1615 KC	High Frequency Stop	*E, F, G
3	0.000068 Mfd.	Antenna Connector	600 KC	Signal Generator Signal	J, K
4	0.000068 Mfd.	Antenna Connector	1615 KC	High Frequency Stop	F, G
5	0.000068 Mfd.	Antenna Connector	1100 KC	Signal Generator Signal	L**

\*Before making this adjustment check mechanical setting of oscillator core "H." The rear of the core should be 1 1/2" from the mounting end of the coil form. (This measurement is readily made by inserting a suitable plug in the mounting end of the coil form.) Core adjustment should be made with a non-metallic screw driver.

\*\*L is the pointer adjustment screw which is on the connecting link, between the pointer assembly and core guide bar (See tuner Dwg.). It should be adjusted so that when looking directly at the dial the pointer is on the 1100 KC mark. This setting is to give the correct relationship between the pointer and the dial when the radio is installed in a car. With the radio installed and the car antenna plugged in adjust the antenna trimmer "G" for maximum volume with the radio tuned to a weak station between 600 and 1000 KC (see sticker on case.)

# DELCO

OLDSMOBILE SUPER DELUXE MODEL 989002

(Alignment and other service material on page 51, adjacent at right.)

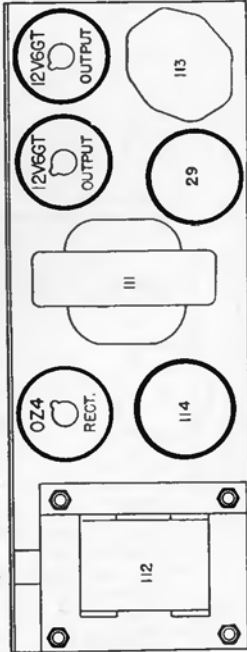
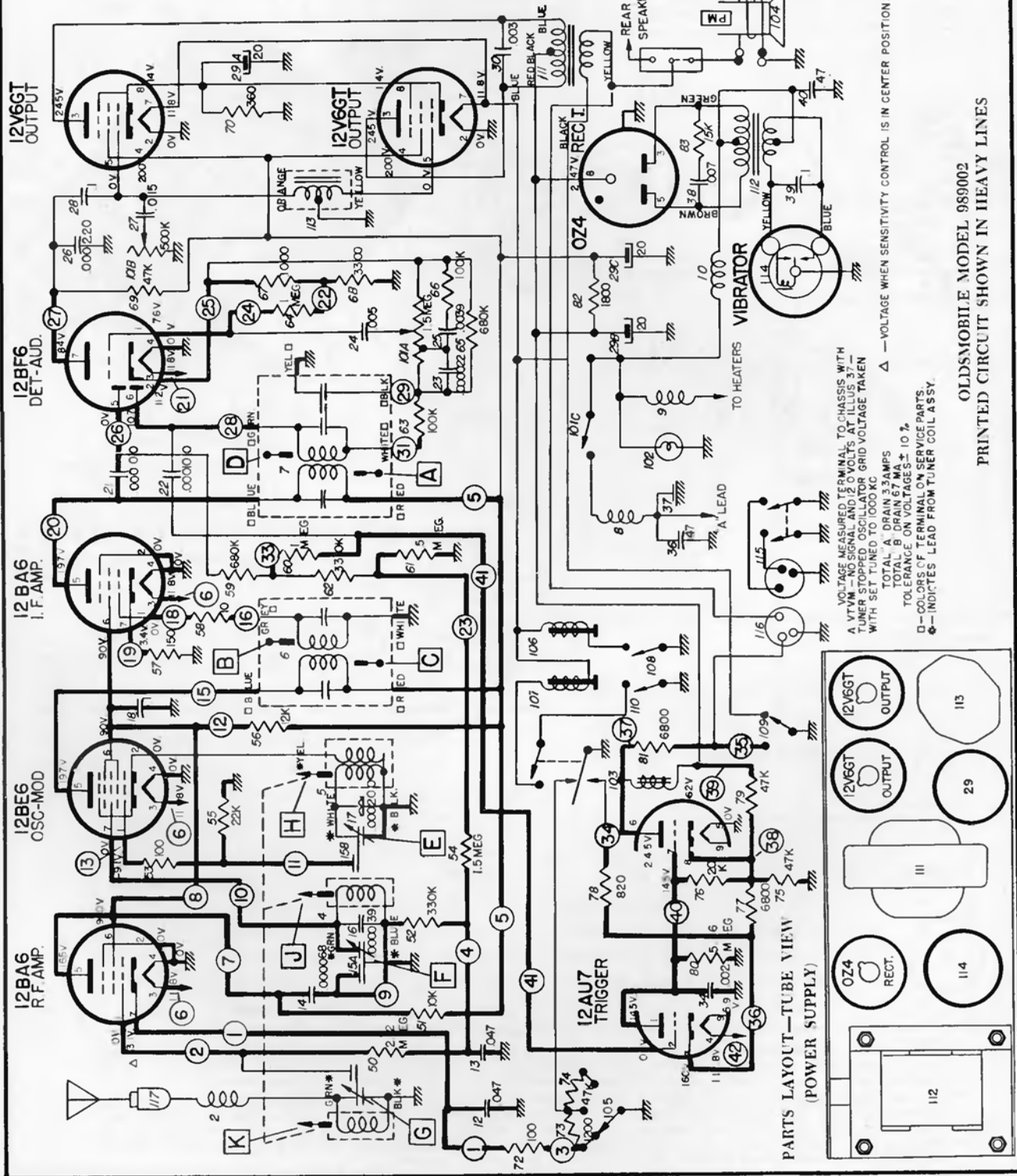
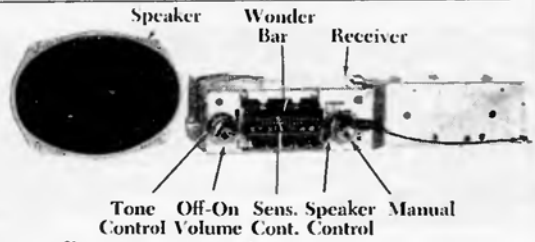

VOLTAGE MEASURED TERMINAL TO CHASSIS WITH A VTVM—NO SIGNAL AND 120 VOLTS AT ILLUS. 37—TUNER STOPPED OSCILLATOR GRID VOLTAGE TAKEN WITH SET TUNED TO 1000 KC  
 TOTAL A DRAIN 33AMPS  
 TOLERANCE ON VOLTAGES ± 10 %  
 D—COLORS OF TERMINAL ON SERVICE PARTS  
 ⊕—INDICATES LEAD FROM TUNER COIL ASSY.

△ —VOLTAGE WHEN SENSITIVITY CONTROL IS IN CENTER POSITION.

OLDSMOBILE MODEL 989002  
 PRINTED CIRCUIT SHOWN IN HEAVY LINES

# DELCO

OLDSMOBILE MODEL 989002

(Continued from page 50)

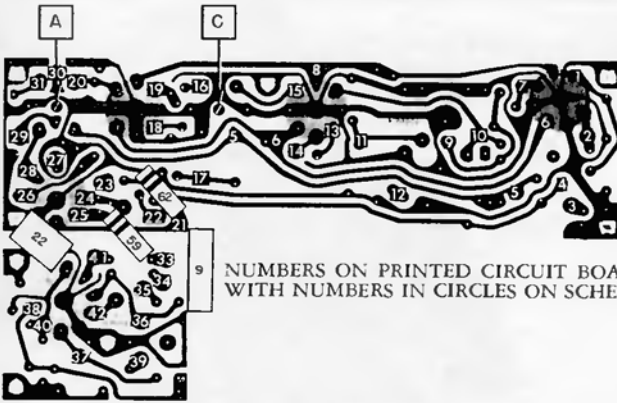

NUMBERS ON PRINTED CIRCUIT BOARD CORRESPOND WITH NUMBERS IN CIRCLES ON SCHEMATIC DIAGRAM.

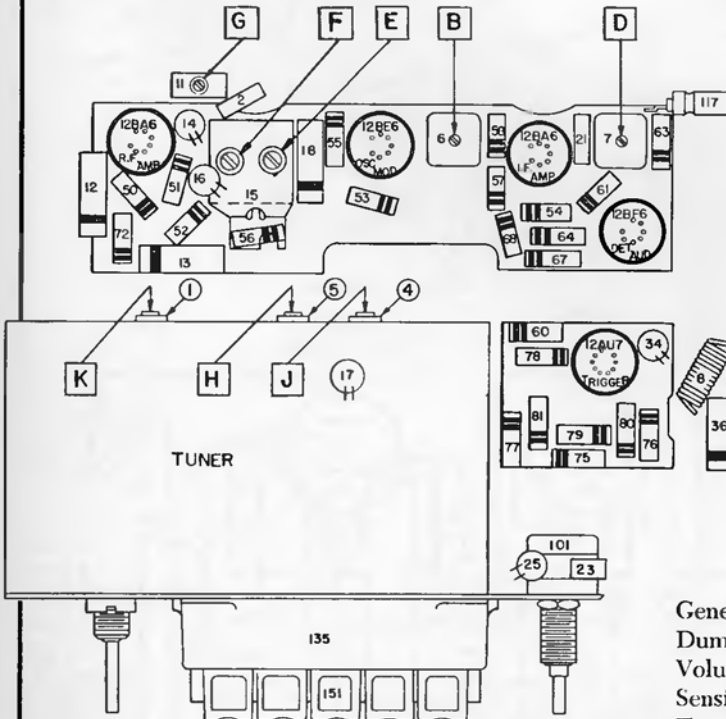

PARTS LAYOUT—TUBE VIEW

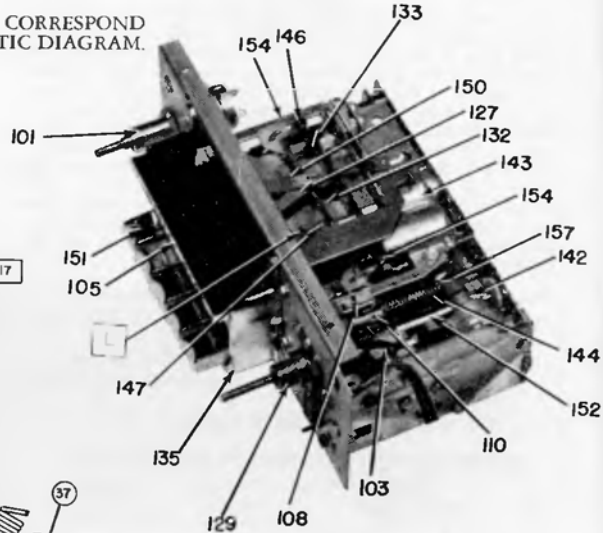

TUNER

### PUSHBUTTON SET-UP

1. Pull button to the left and out.
2. Tune in desired station manually.
3. Push button all the way in.

### ALIGNMENT PROCEDURE:

- Generator Return ----- Receiver Chassis
- Dummy Antenna ----- In Series With Generator
- Volume Control ----- Maximum Volume
- Sensitivity Control Position I. (Position I is Maximum)
- Tone Control ----- Treble (max. clockwise)
- Generator Output ----- Not to Exceed 2 Volts at VTVM

Connect vacuum tube voltmeter between AVC line (island #4 on printed circuit board) and ground during alignment.

Step	Dummy Antenna	Connect To	Signal Generator Frequency	Tune Receiver To	Adjust in Sequence
1	0.1 mfd.	12BE6 Grid (Pin 7)	262 KC	°High Frequency Stop	A, B, C (Max.)
2	0.1 mfd.	12BE6 Grid (Pin 7)	262 KC	High Frequency Stop	D (Min.)
3	0.000068 mfd.	Antenna Connector	1615 KC	High Frequency Stop	°°E, F, G (Max.)
4	0.000068 mfd.	Antenna Connector	600 KC	Signal Generator Signal	J, K (Max.)
5	0.000068 mfd.	Antenna Connector	1615 KC	Signal Generator Signal	F, G (Max.)
6	0.000068 mfd.	Antenna Connector	1100 KC	Signal Generator Signal	°°°L

°To tune to high frequency, put a 0.012" feeler gauge (or bare #28 wire) in slot against the high frequency stop. (See tuner pictures). Turn manual control to allow the treadle bar arm to run against the feeler gauge.

°°Before making this adjustment, check the setting of oscillator core "H." The rear of the core should be 1 3/8" from the mounting end of the coil form. This measurement is readily made by inserting a suitable plug in the mounting end of the coil form. The core adjustment is made from the mounting end of the coil form with a non-metallic screw driver. If this adjustment is necessary, first dissolve the glyptal seal on the core stud and be sure to re-seal after making the adjustment.

°°°"L" is the pointer adjustment screw on the end of the core guide bar — adjust so pointer reads 1100 KC. With the radio installed and the antenna plugged in, adjust the antenna trimmer "G" for maximum volume with the radio tuned to a weak station between 600 and 1000 KC (see sticker on case).

# DELCO

OLDSMOBILE MODEL 989127

(Continued on page 53)

## TROUBLE SHOOTING THE OUTPUT STAGE

A quick way to determine that the 2N278 is conducting can be made by checking the collector voltage, from transistor case to the radio case. If no voltage is present, the transistor is not conducting or the transistor heat radiator is grounded to the radio case. If the voltage at the collector is higher than listed, the transistor is conducting too heavily (check with milliammeter) or the output transformer is open. The amount of current the transistor conducts is determined by the voltages at each element, the resistor in the base and emitter circuits, the input transformer secondary resistance, and the transistor itself. The most common defect in the transistor is an internal short between emitter and collector. To check for this, use the following procedure.

1. Unsolder base and emitter leads from the circuit.
2. Set ohmmeter on the "R x 1" scale (no other scale should be used.)
3. Place negative lead of ohmmeter (polarity refers to internal ohmmeter battery) on collector, and positive lead on the emitter.
4. The transistor is shorted if reading is "0".

PRINTED CIRCUIT SHOWN IN HEAVY LINES.

**12BL6**  
R.F. AMP.

**12AD6**  
OSC.-MOD.

**12AF6**  
I. F. AMP.

**12F8**  
DET.-1ST AUDIO

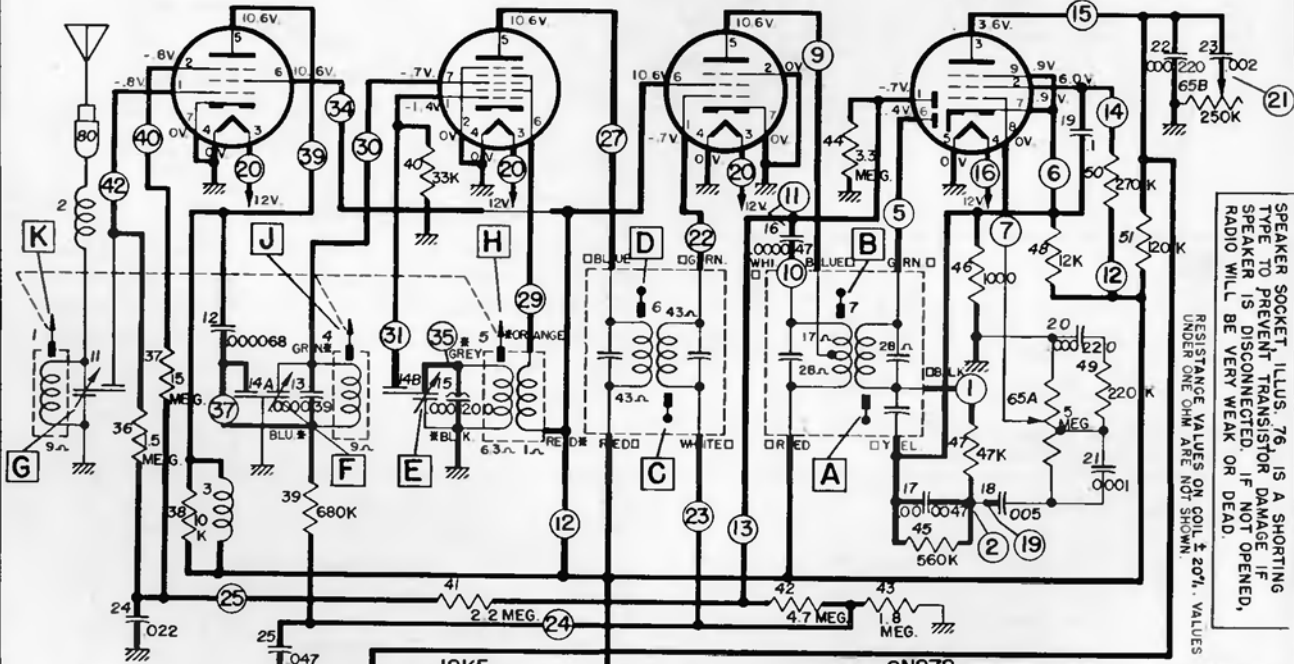

VOLTAGE MEASURED TERMINAL TO CHASSIS WITH A VTVM-NO SIGNAL AND 12.0 VOLTS AT ILLUS. 31. OSCILLATOR GRID VOLTAGE TAKEN WITH SET TUNED TO 1000KC.

TOTAL "A" DRAIN AT 12V.-2.3 AMPS. TOLERANCE ON VOLTAGES ± 10%.

□ - COLORS OF TERMINALS ON SERVICE PARTS  
 \* - INDICATES LEAD FROM TUNER COIL ASSY  
 \*\* - BEFORE MEASURING TRANSISTOR VOLTAGES, THE SHORTING-TYPE SPEAKER SOCKET MUST BE OPENED AND A 4 OHM SPEAKER CONNECTED. IF TRANSISTOR IS REPLACED, ADJUST BIAS POTENTIOMETER (ILLUS. 66) TO OBTAIN PROPER COLLECTOR VOLTAGE WITH 12 VOLTS INPUT TO RADIO.

† - ILLUS 58 IS A FUSE RESISTOR FOR THE TRANSISTOR. VALUE IS .36 OHMS AT ROOM TEMPERATURE.

**12K5**  
AUDIO-AMP.

**2N278**  
OUTPUT

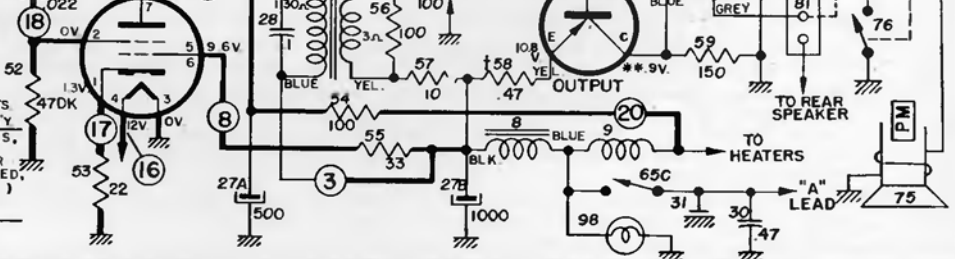

**C MOST-OFTEN-NEEDED 1958 RADIO SERVICING INFORMATION**

DE LCO  
 OLDSMOBILE Model 989127  
 (Continued from page 52)

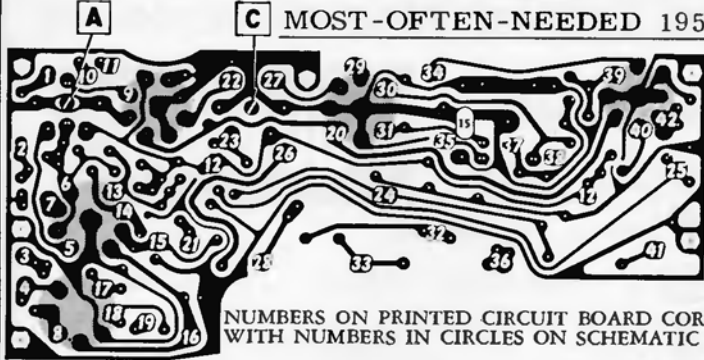

NUMBERS ON PRINTED CIRCUIT BOARD CORRESPOND WITH NUMBERS IN CIRCLES ON SCHEMATIC DIAGRAM.

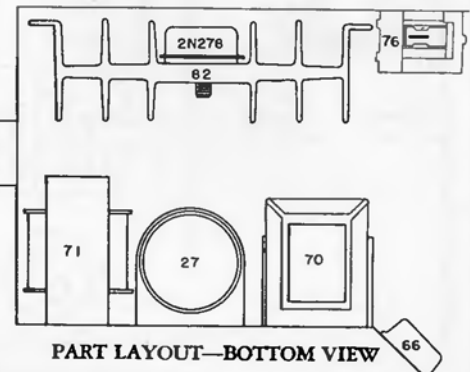

PART LAYOUT—BOTTOM VIEW

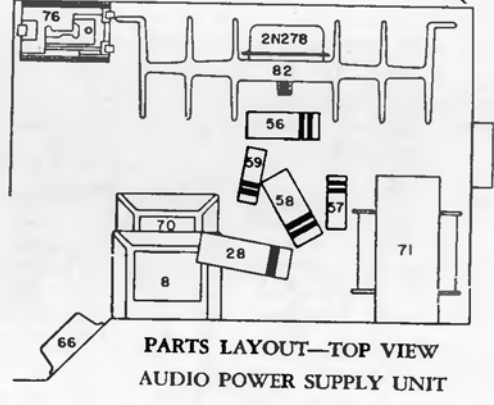

PARTS LAYOUT—TOP VIEW  
 AUDIO POWER SUPPLY UNIT

**ALIGNMENT PROCEDURE**

- Output Meter Connections.....Across Voice Coil Generator Return.....To Receiver Chassis
- Dummy Antenna.....In Series With Generator
- Volume Control Position.....Maximum Volume
- Tone Control Position.....Treble Position
- Generator Output.....Minimum for Readable Indication

CONNECT VACUUM TUBE VOLTMETER ACROSS SPEAKER VOICE COIL DURING ALIGNMENT.

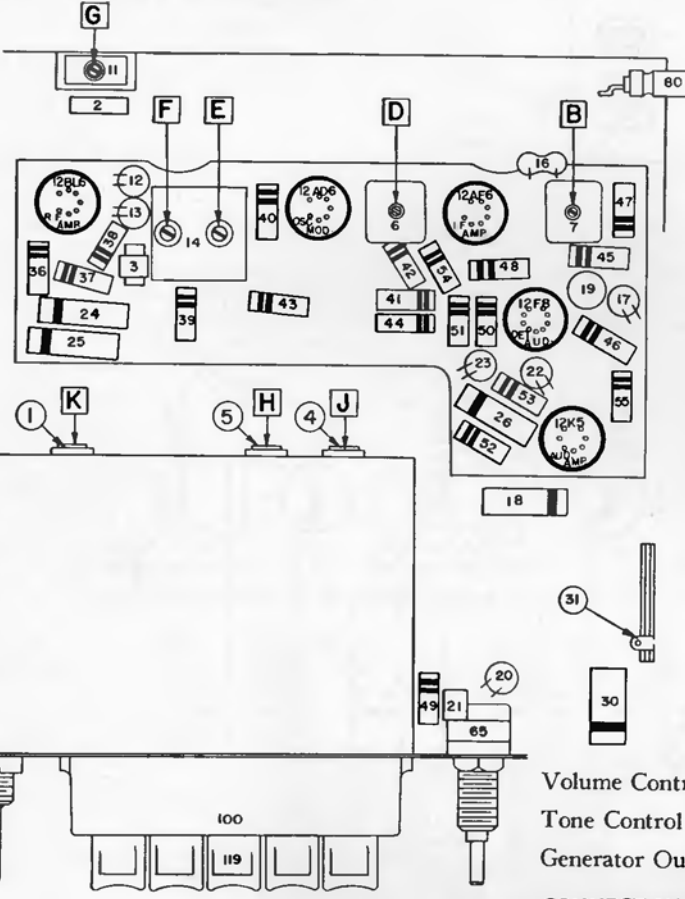

PARTS LAYOUT—TUBE VIEW

Steps	Series Capacitor or Dummy Antenna	Connect Signal Generator to	Signal Generator Frequency	Tune Receiver to	Adjust in Sequence For Max. Output
1	0.1 Mfd.	12AD6 Grid (Pin #7)	262 KC	High Frequency Stop	A, B, C, D
2	0.000068 Mfd.	Antenna Connector	1615 KC	High Frequency Stop	*E, F, G
3	0.000068 Mfd.	Antenna Connector	600 KC	Signal Generator Signal	J, K
4	0.000068 Mfd.	Antenna Connector	1615 KC	High Frequency Stop	F, G
5	0.000068 Mfd.	Antenna Connector	1100 KC	Signal Generator Signal	L**

\*Before making this adjustment check mechanical setting of oscillator core "H." The rear of the core should be 1/16" from the mounting end of the coil form. (This measurement is readily made by inserting a suitable plug in the mounting end of the coil form.) Core adjustment should be made with a non-metallic screw driver.

\*\*L is the pointer adjustment which is on the connecting link, between the pointer assembly and core guide bar (See tuner Dwg.). It should be adjusted so that when looking directly at the dial the pointer is on the 1100 KC mark. This setting is to give the correct relationship between the pointer and the dial when the radio is installed in a car.

With the radio installed and the car antenna plugged in adjust the antenna trimmer "G" for maximum volume with the radio tuned to a weak station between 600 and 1000 KC (see sticker on case.)



Model 1210 (RA-902)

(Continued on page 55, adjacent at right.)

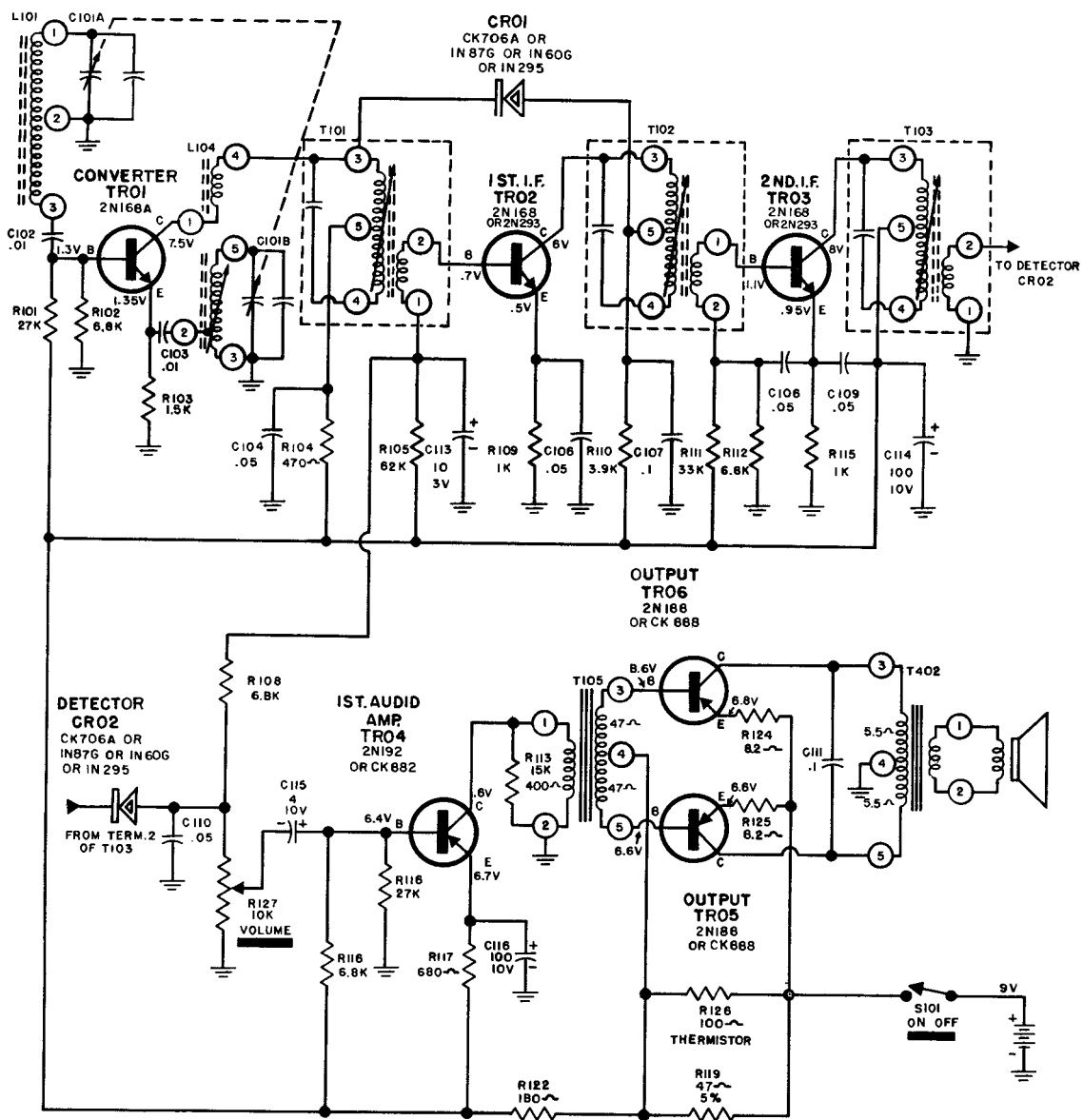
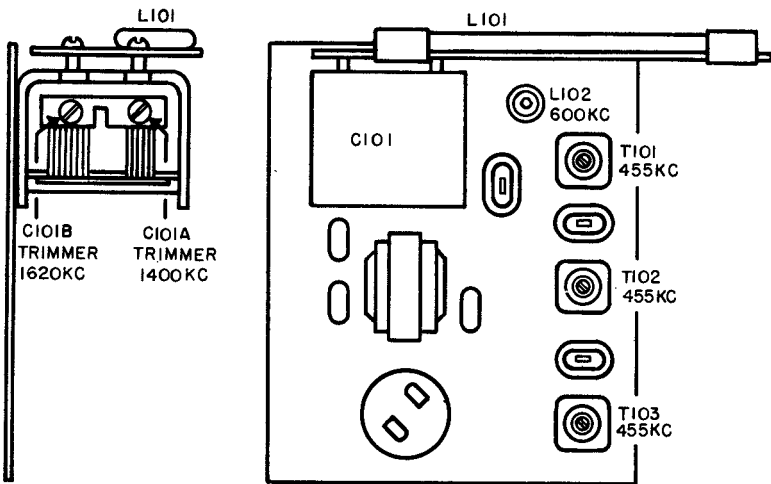

# DU MONT

## MODEL 1210 (RA-902)

(Continued from page 54, adjacent at left)

### ALIGNMENT INSTRUCTIONS

Turn volume control fully clockwise. Adjust the generator for the lowest signal necessary to obtain an output reading (no more than .5 volts across speaker voice coil). Make all adjustments with an insulated alignment tool. Caution: Do not remove or insert transistors while power is on.

Step	Signal Generator		Tuning Capacitor Setting	Output Meter Connection	Adjust
	Frequency	Connect to			
1	455 KC 400 cps AM Mod.	Loop, of several turns of wire placed near AM antenna	Maximum Capacity		I. F. Transformers T103, T102 and T101 in this order for maximum output indication. Repeat once.
2	1620 KC 400 cps AM Mod.	As Above	Minimum Capacity		Oscillator trimmer capacitor of C101B until signal is heard, but don't attempt to tune for peak output. Note: If signal cannot be heard adjust antenna trimmer capacitor of C101A.
3	As Above	As Above, except move loop several feet away for very weak signal.	As Above		Antenna trimmer capacitor of C101A for maximum signal output. Retouch oscillator trimmer for maximum output.
4	600 KC 400 cps AM Mod.	As Above	Set tuning dial for strongest 600 KC signal		Oscillator coil, L102, rocking tuning capacitor back and forth until signal reaches maximum.
5	1400 KC 400 cps AM Mod.	As Above	Set tuning dial for strongest 1400 KC signal		Antenna trimmer capacitor of C101A, and at the same time rocking tuning capacitor back and forth until signal reaches maximum. Note: Repeat steps 4 and 5 if necessary.

NOTE: When the chassis and/or battery compartment are reinstalled in the case, tune the radio to a weak AM station above 1400 KC, and retouch the antenna trimmer capacitor, C101A, for peak performance.

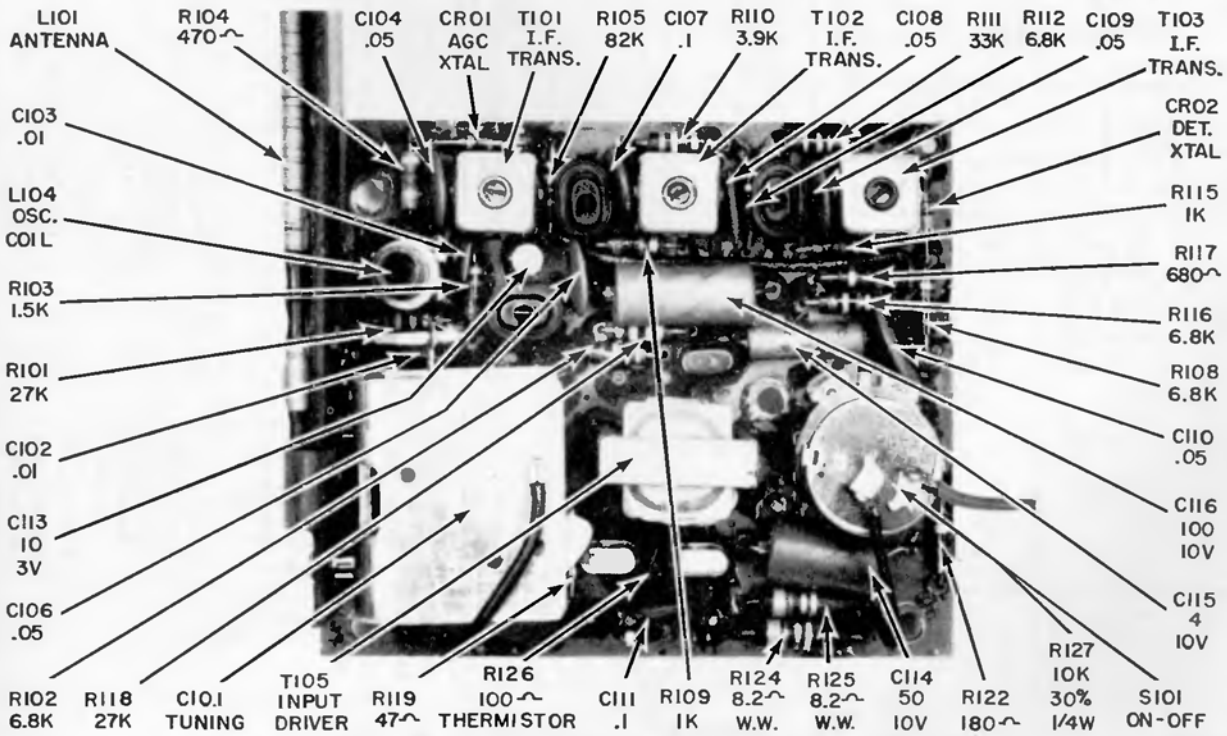

Component location view of the Model 1210 "Transistor" portable radio.

# EMERSON RADIO

CHASSIS 120355B, MODEL 871B

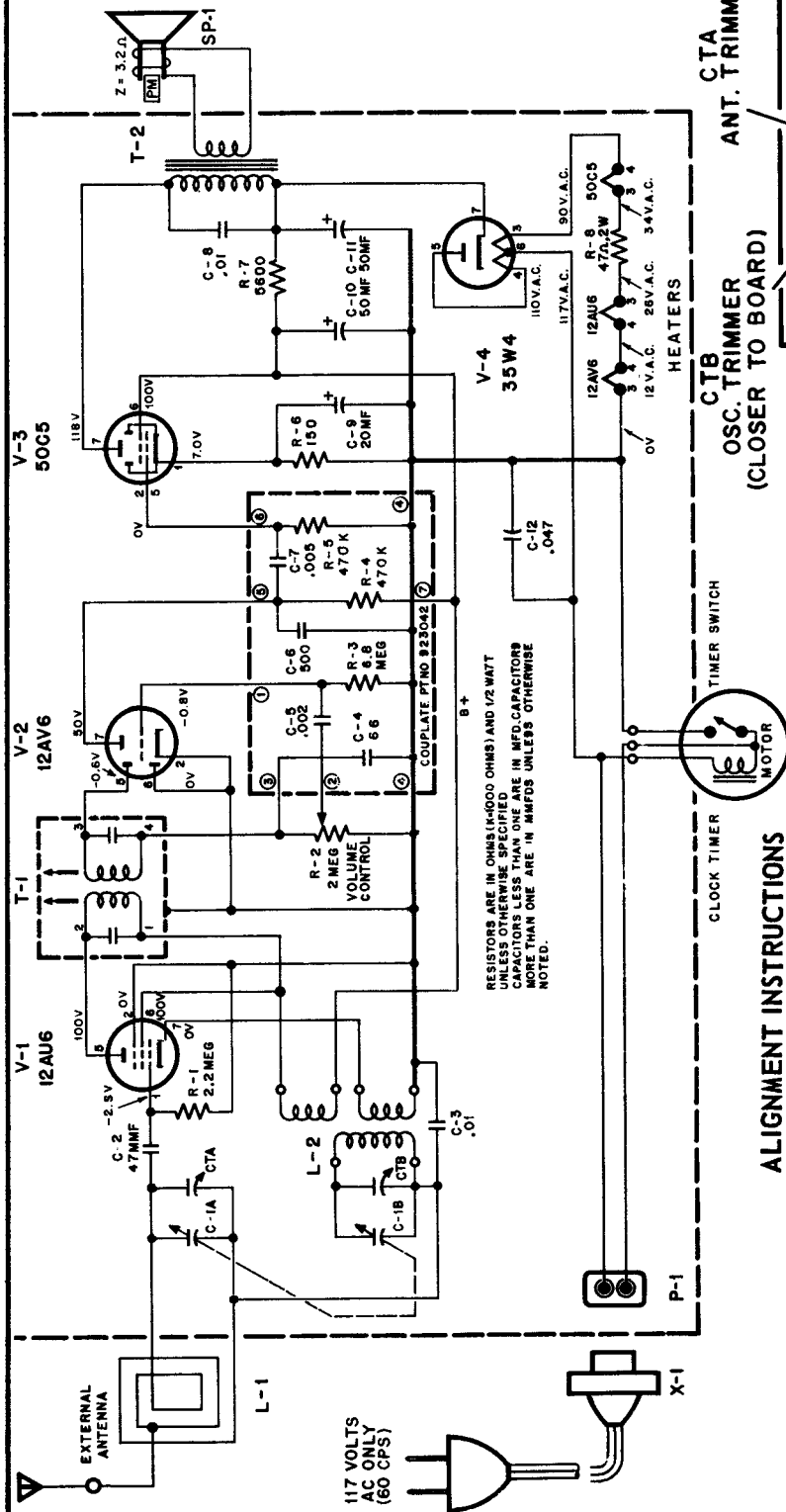

## ALIGNMENT INSTRUCTIONS

STEP	DUMMY ANTENNA	SIGNAL GENERATOR COUPLING	SIGNAL GENERATOR FREQUENCY	RADIO DIAL SETTING	OUTPUT METER	ADJUST	REMARKS
1	.005 mfd.	High side to grid (pin 1) of V1 (12AU6). Low side to B-neutral.	455 KC	**Variable condenser fully open.	Across voice coil.	T1 Top and bottom.	Adjust for maximum output.
2		Form loop of several turns and radiate signal into receiver	1620 KC	Variable condenser fully open.	Across voice coil.	Trimmer (Osc.) CTB	Adjust for maximum output.
3		Form loop of several turns and radiate signal	1400 KC	Tune for maximum output.	Across voice coil.	Trimmer (Ant.) CTA	Adjust for maximum output. (Repeat steps 2 and 3 for optimum results.)

\*\* In the event spurious oscillation is present, adjust variable condenser (towards fully closed position) until oscillation is eliminated and



# Emerson Radio

MODELS 851B, 870B,  
874B  
CHASSIS 120363A

## REPAIR OF COUPLATES

Whenever possible couplates should be repaired instead of replaced. This practice could readily become a time saving factor.

**Example #1**  
Shorted .005 mfd condenser C-6. Clip off pin 6 of couplate from printed board. This removes C-6 and R-7 from the circuit.

Insert a regular 470K ohm 1/2 watt resistor (to pin 2 of V-4 and a regular .005 mfd 400V condenser from pin 2 of V-4 to pin 5 of Couplate.

**Example #2**  
Open R-7 470K ohm resistor. Insert regular 470K ohm 1/2 watt resistor across pins 4 and 6 of Couplate.

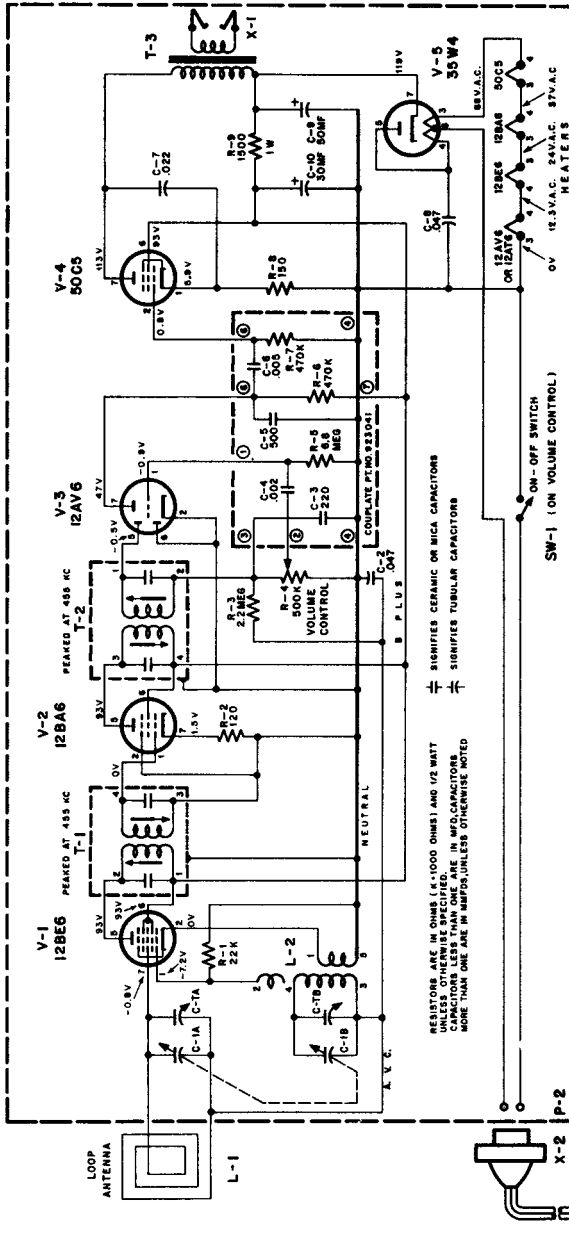

SYM.	PART NO.	DESCRIPTION	PART NO.	DESCRIPTION
C-10	Pt. of C-9	30 MF Electrolytic	150V	
R-1	340812	22,000 OHM - Carbon ± 10%	1/2W	
R-2	340272	120 OHM - Carbon ± 10%	1/2W	
R-3	351292	2.2 MEGOHM - Carbon ± 20%	1/2W	
R-4	390448	500,000 OHM - Volume Control	1/2W	
R-8	340292	150 OHM - Carbon ± 10%	1/2W	
R-9	380532	1,500 OHM - Carbon ± 20%	1 W	
L-1	700118	Loop Antenna & Back Assembly		
L-2	716108	Oscillator Coil		
T-1	720294	1st I.F. Transformer		
T-2	720295	2nd I.F. Transformer		
T-3	734138	Audio Output Transformer		

SYMBOL	TUBE	PIN 1	PIN 2	PIN 3	PIN 4	PIN 5	PIN 6	PIN 7
V-1	12BE6	22K	1.0Ω	32Ω	22Ω	+1500Ω	+1500Ω	3 MEG
V-2	12BA6	15Ω	0	32Ω	42Ω	+1500Ω	+1500Ω	120Ω
V-3	12AT6 or 12AV6	6.8 MEG	0	0	22Ω	500K	0	*470K
V-4	50C5	150Ω	470K	42Ω	93Ω	500K	+1500	*140Ω
V-5	35W4	N.C.	N.C.	85Ω	120Ω	125Ω	115Ω	†1 MEG

† Wait for meter to settle (about 30 seconds).  
\* Resistances measured to Pin 7 of 35W4 (Bt).

### RESISTANCE READINGS

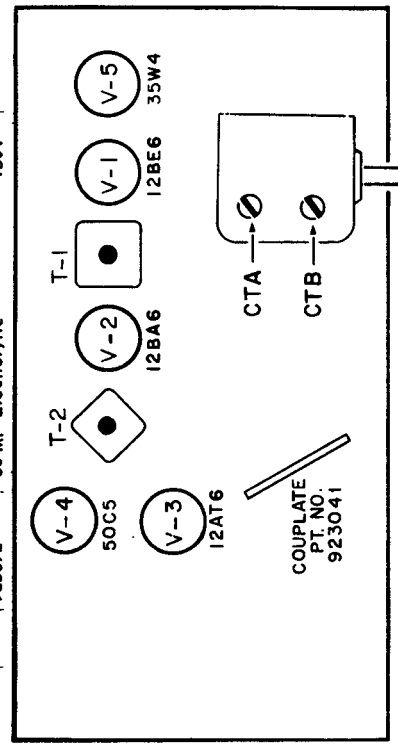

### TUBE AND TRIMMER LOCATION

# Emerson Radio

MODEL - 867B  
CHASSIS - 120366B

This model is identical to the model 867B using chassis 120349B except for the substitution of a couplate (Emerson Pt. No. 923041) and individual components on chassis 120366B for the two modules used on chassis 120349B.

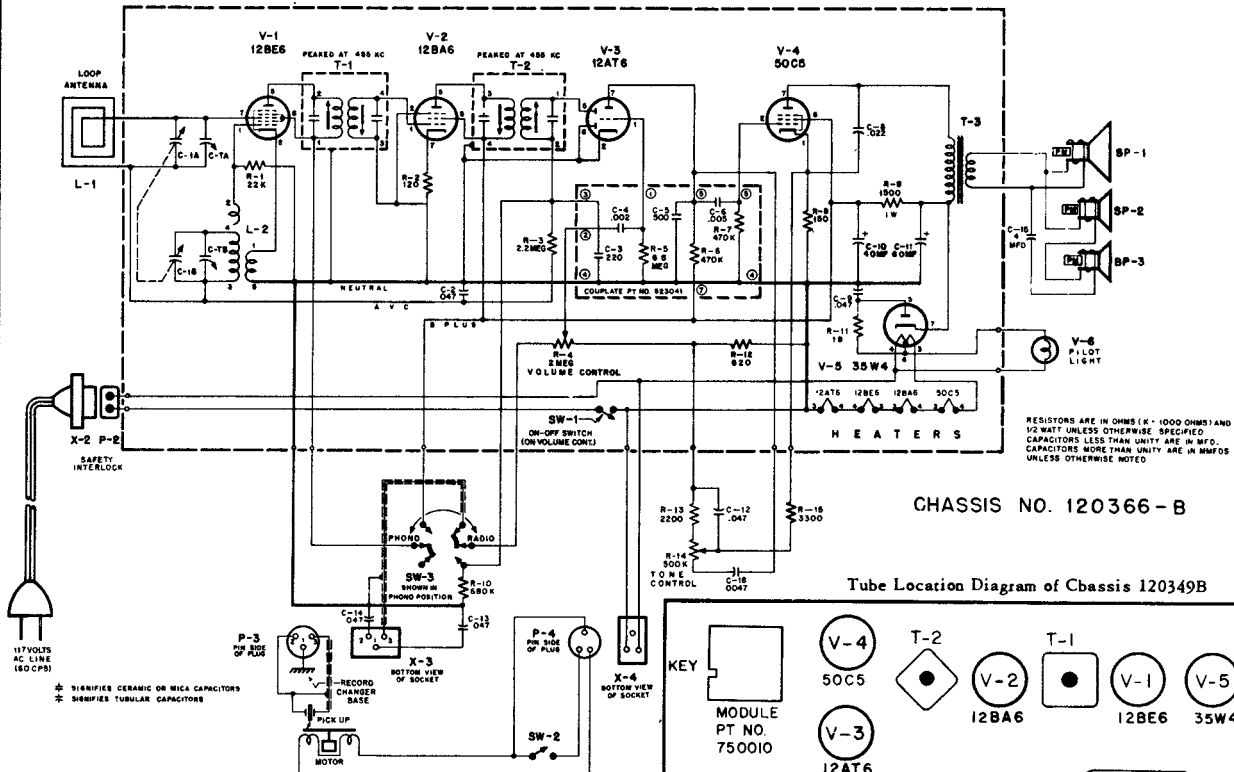

### DISASSEMBLY INFORMATION

1. Remove all knobs and remove masonite back.
2. Remove 2 "C" and 2 standard washers securing changer hold down bolts to mounting board (which is part of cabinet), remove 2 three-prong plugs and remove changer (unstaple fish paper wire holders.)
3. To remove radio:
  - a) Remove AC interlock, slide off pilot light assembly.

- b) Unsolder 2 speaker leads at SP-1 (Woofer), remove antenna assembly from bracket.
- c) Remove Phillips head screws securing radio to cabinet (on top).
- d) Remove 45 r.p.m. spindle holder.

4. To reassemble, reverse procedures #1 through #3.

### ALIGNMENT INSTRUCTIONS

STEP	DUMMY ANTENNA	SIGNAL GENERATOR COUPLING	SIGNAL GENERATOR FREQUENCY	RADIO DIAL SETTING	OUTPUT METER	ADJUST	REMARKS
1	.005 mfd.	High side to grid (pin 7) of V1 (12BE6). Low side to B-neutral (See item 2 under alignment instructions).	455 KC	Variable condenser fully open.	Across voice coil.	T2, T1	Adjust for maximum output.
2		Form loop of several turns and radiate signal into receiver	1620 KC	"	Across voice coil.	Trimmer C-TB (Osc.)	Adjust for maximum output.
3			1400 KC	Tune for maximum output.	Across voice coil.	Trimmer C-TA (Ant.)	Adjust for maximum output.

# Emerson

Chassis 120374, Model 888

## ALIGNMENT INSTRUCTIONS

Volume control should be at maximum; output of signal generator should be no higher than necessary to obtain an output reading with a 30% audio modulated R.F. Use an insulated alignment screwdriver for adjusting.

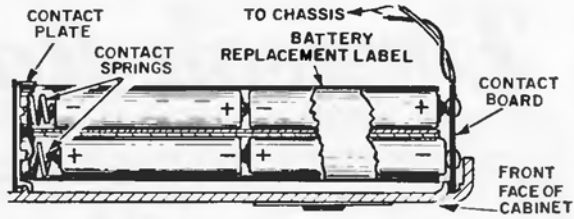

	DUMMY ANTENNA	SIGNAL GENERATOR COUPLING	SIGNAL GENERATOR FREQUENCY	RADIO DIAL SETTING	OUTPUT METER	ADJUST	REMARKS
1	.1 mfd.	High side to junction of L-1 & C-1. Low side to chassis.	455 KC.	Tuning condenser fully open.	Across voice coil.	T2, T3 and T1	Adjust for maximum output starting with T3.
2		Use a loop set perpendicular and about 20" from center of bar loop ant. in set.	1650 KC.	Tuning condenser fully open.	Across voice coil.	CT2 (osc. trimmer)	Fashion loop of several turns of wire and radiate signal into bar loop of receiver. Adjust for maximum output.
3		"	1400 KC.	Tune for maximum output.	Across voice coil.	CT1 (Ant. trimmer)	Adjust for maximum output.
4		"	600 KC.	Tuning condenser set for 600 KC.	Across voice coil.	Osc. slug in L-2	Rock the variable cond. each side of 600 KC while adj. osc. slug for maximum response.
5		"	1650 KC.	Tuning condenser fully open.	"	CT2 Osc. trimmer	If readjustment is necessary repeat steps 2 to 4 until no further improvement is noted.

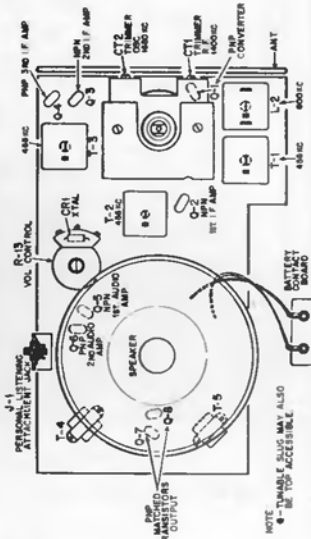

NOTE: For optimum results, repeat entire alignment procedure.

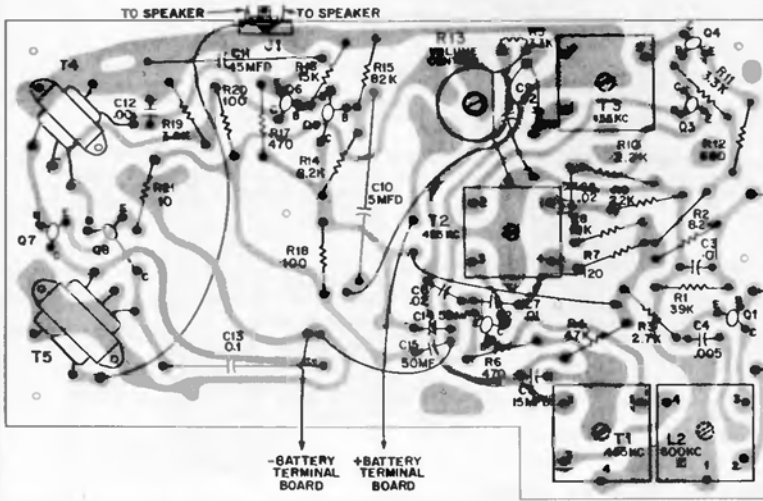
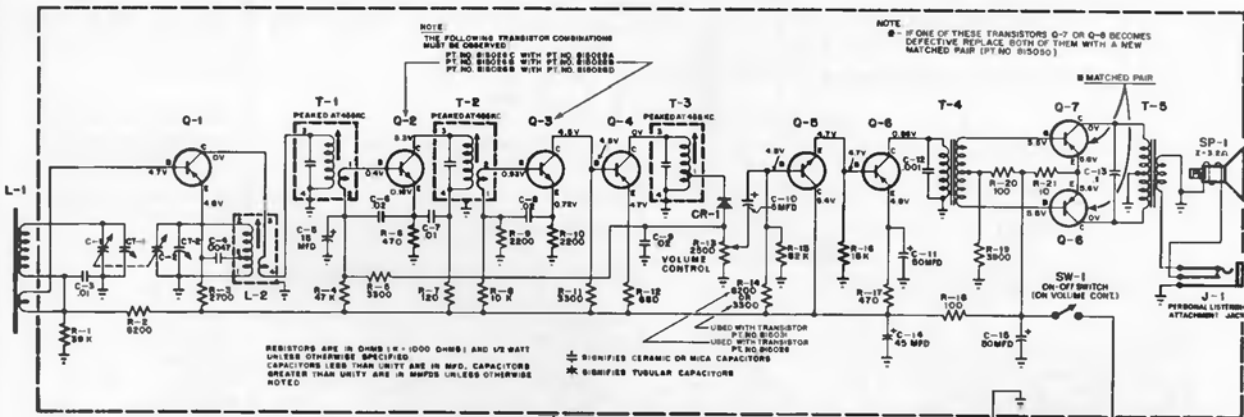

### CONDITIONS FOR VOLTAGE READINGS

1. Voltages indicated are positive D.C.
  2. Measurements taken with V.T.V.M.
  3. All Measurements taken between points and chassis.
  4. Voltage measurements taken with:
    - (a) Fresh 6 Volt battery supply. Four 1½ Vqft conventional penlight cells.  
Note: Should Mercury or Nickel-Cadmium batteries be used, an approx. 15% lower voltage reading will be obtained from the battery supply which is considered to be perfectly normal.
    - (b) Volume control set for maximum volume.
    - (c) Variable capacitor fully closed and no signal applied.
  5. Nominal tolerances in component values make possible a variation of ± 15% in readings.
- Caution - When taking voltage checks, avoid accidental shorting across transistor leads as they may cause transistor damage. Do not use a non-vacuum tube-type voltmeter as the relatively low shunt resistance of this type of voltmeter can easily disrupt the transistor bias and result in erroneous readings as well as damage to the transistor.

# Emerson Radio

(Material continued on the next page adjacent at right)

MODEL - 885B  
 CHASSIS - 120371B  
 MODEL - 886B  
 CHASSIS - 120371B

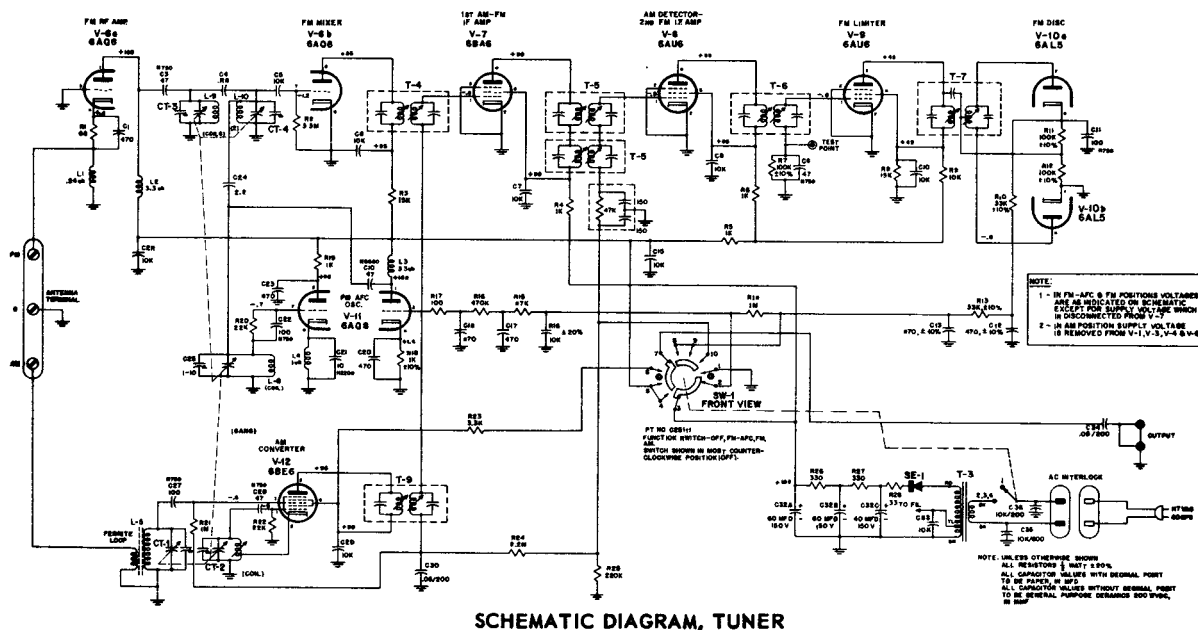
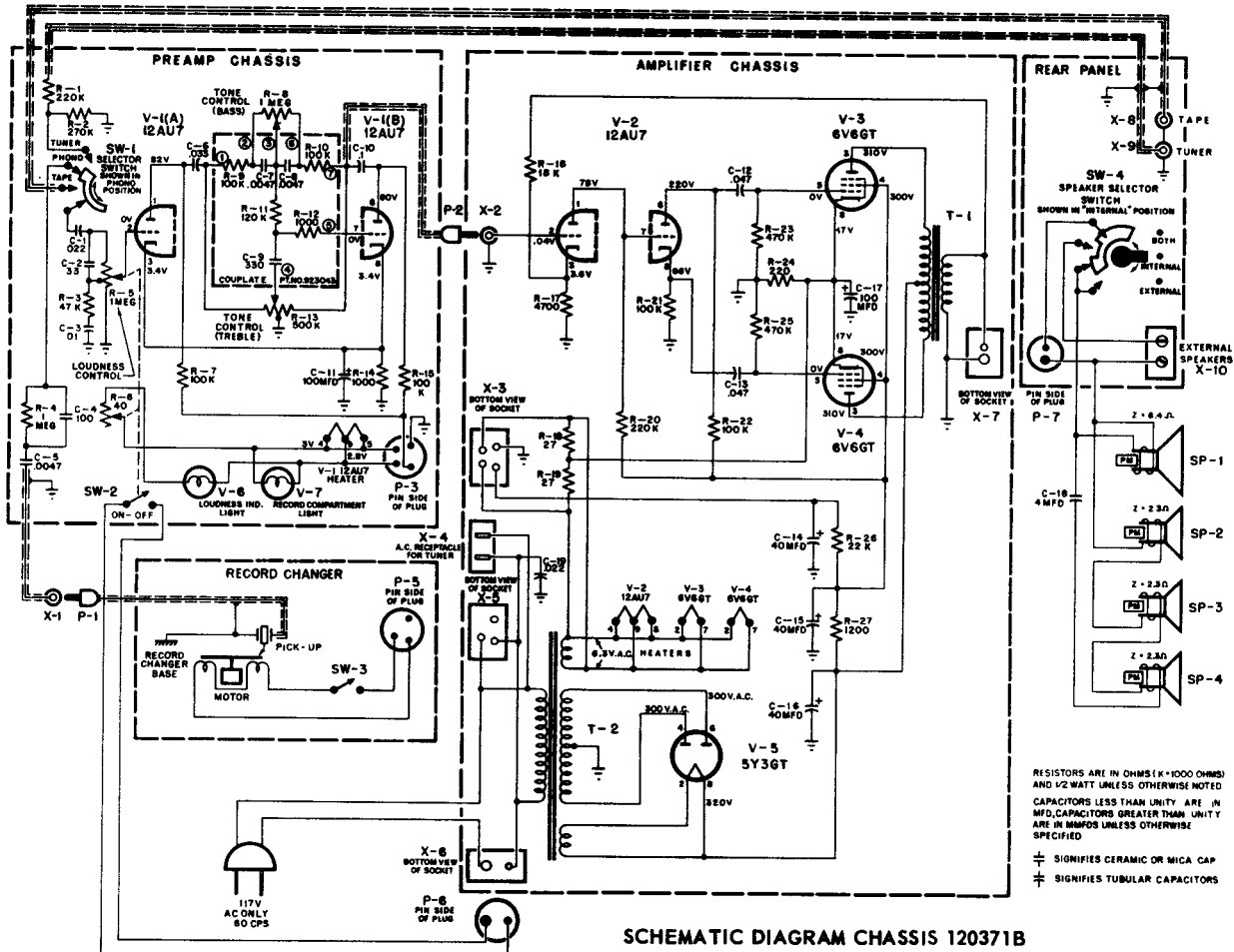

# Emerson

CHASSIS 120371B  
 Models 885B and 886B  
 (Continued from preceding page adjacent at left.)

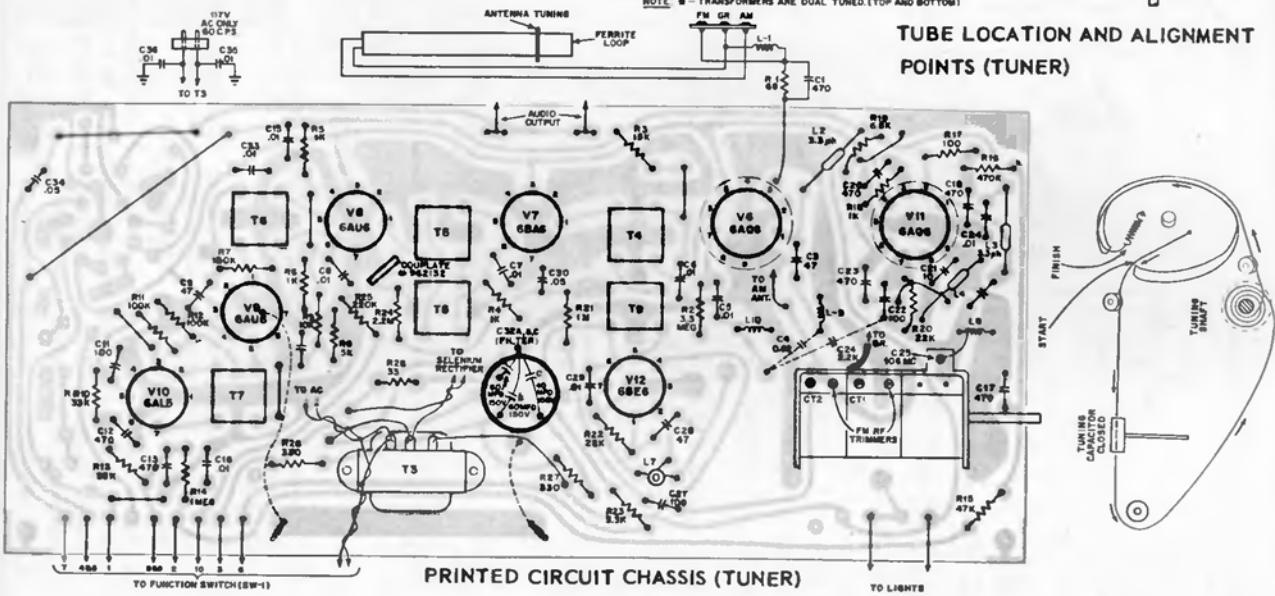
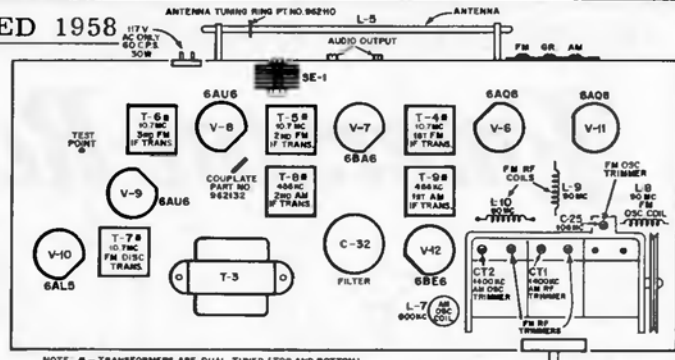

### ALIGNMENT INSTRUCTIONS (AM)

Selector Switch set to AM position; output of signal generator should be no higher than necessary to obtain an output reading with a 40% modulated R.F. Use an insulated alignment screw driver for adjustments.

STEPS	SIGNAL GENERATOR COUPLING	SIGNAL GENERATOR FREQUENCY	RADIO DIAL SETTING	OUTPUT METER VTVM OR SCOPE	ADJUST	REMARKS
1	High side to junction L-5 and C-27. Low side to chassis ground.	455 kc	Tuning condenser fully open	Across tuner output	T-8 T-9 Top & Bot.	Adjust for maximum output
2	High side to AM ont. terminal. Low side to chassis ground.	1400 kc	1400 kc	Across tuner output	CT-1 CT-2	Adjust for maximum output
3	High side to AM ant. terminal. Low side to chassis ground.	600 kc	600 kc	Across tuner output	L-5 L-7	Adjust for maximum output (L-7 adjusted by sliding tuning ring on loopstick)
4	1400 kc	REPEAT STEP NO. 2				

### FM ALIGNMENT INSTRUCTIONS

Selector Switch to FM position; sweep generator  $\pm 300$  KC. Marker generator as indicated.

1	High side to junction of L-10 & CT-4. Low side to chassis ground.	10.7 mc	Tuning condenser fully open	Test point and chassis	Top & Bot. T-6, T-5, T-3	Adjust for maximum gain & symmetry.
2	High side to junction of L-10 & CT-4. Low side to chas. ground.	10.7 mc	Tuning condenser fully open	Across tuner output	T-7 top & bot.	Adjust for maximum gain & symmetry (S pattern) See Fig. 7.
3	High side to FM ont. term. Low side to chassis ground.	106 mc	106 mc	Test point and chassis	C-25 CT3 CT4	Adjust for maximum output
4	High side to FM ant. term. Low side to chassis ground.	90 mc	90 mc	Test point and chassis	L8, L9, L10	Adjust (by spreading and/or compressing coils with non-metallic screw driver) for maximum output.

DIAL CORD STRINGING DIAGRAM (TUNER)

# Emerson Radio

MODEL - 875-B

CHASSIS - 120365B

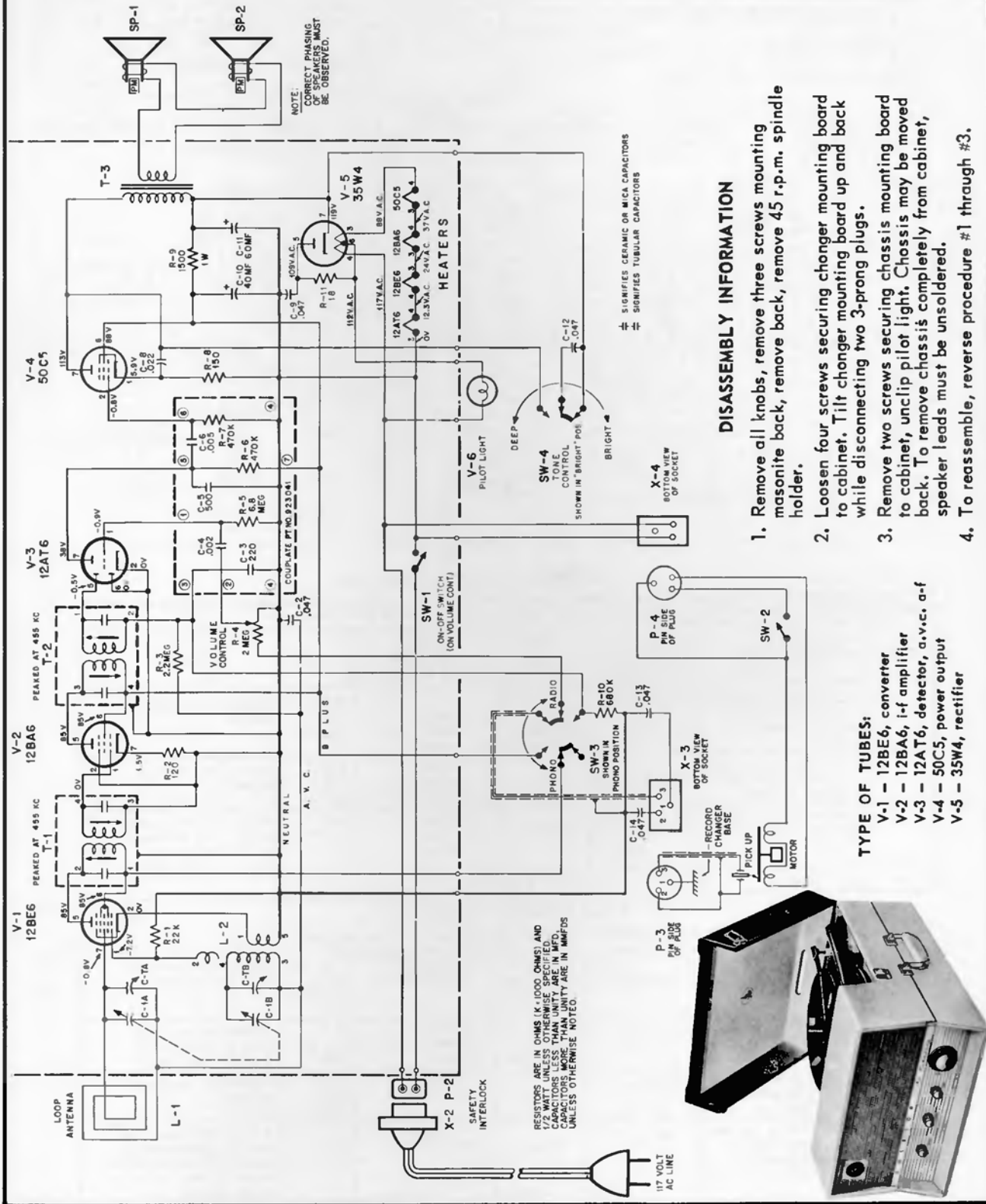

### DISASSEMBLY INFORMATION

1. Remove all knobs, remove three screws mounting masonite back, remove back, remove 45 r.p.m. spindle holder.
2. Loosen four screws securing changer mounting board to cabinet. Tilt changer mounting board up and back while disconnecting two 3-prong plugs.
3. Remove two screws securing chassis mounting board to cabinet, unclip pilot light. Chassis may be moved back. To remove chassis completely from cabinet, speaker leads must be unsoldered.
4. To reassemble, reverse procedure #1 through #3.



# EMERSON RADIO

- MODEL - 876B  
CHASSIS - 120398B
- MODEL - 881B  
CHASSIS - 120373B
- MODEL - 882B, 883B,  
884B  
CHASSIS - 120372B

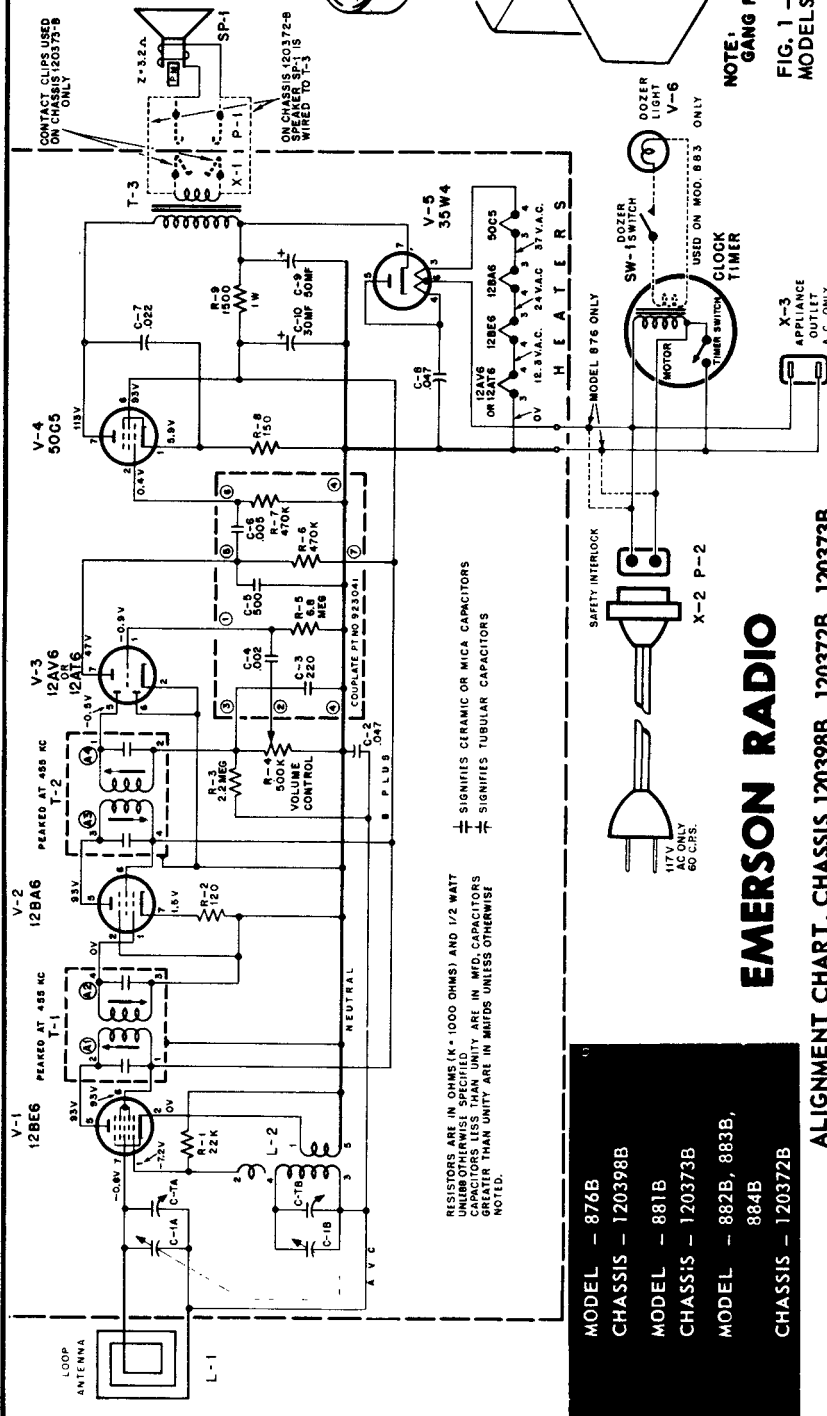

# EMERSON RADIO

- MODEL - 876B  
CHASSIS - 120398B
- MODEL - 881B  
CHASSIS - 120373B
- MODEL - 882B, 883B,  
884B  
CHASSIS - 120372B

ALIGNMENT CHART, CHASSIS 120398B, 120372B, 120373B

STEP	DUMMY ANTENNA	SIGNAL GENERATOR COUPLING	SIGNAL GENERATOR FREQUENCY	RADIO DIAL SETTING	OUTPUT METER	ADJUST	REMARKS
1	.005 mfd.	High side to grid (pin 7) of V1 (12BE6). Low side to B-neutral (See Alignment Note)	455 KC	Variable condenser fully open.	Across voice coil.	T2, T1 (A3, A4, A1, A2)	Adjust for maximum output.
2		Form loop of several turns and radiate signal into receiver	1620 KC	Variable condenser fully open.	Across voice coil.	Trimmer C-TB (Osc.)	Adjust for maximum output.
3		Form loop of several turns and radiate signal into receiver	1400 KC	Tune for maximum output.	Across voice coil.	Trimmer CTA (Ant.)	Adjust for maximum output.

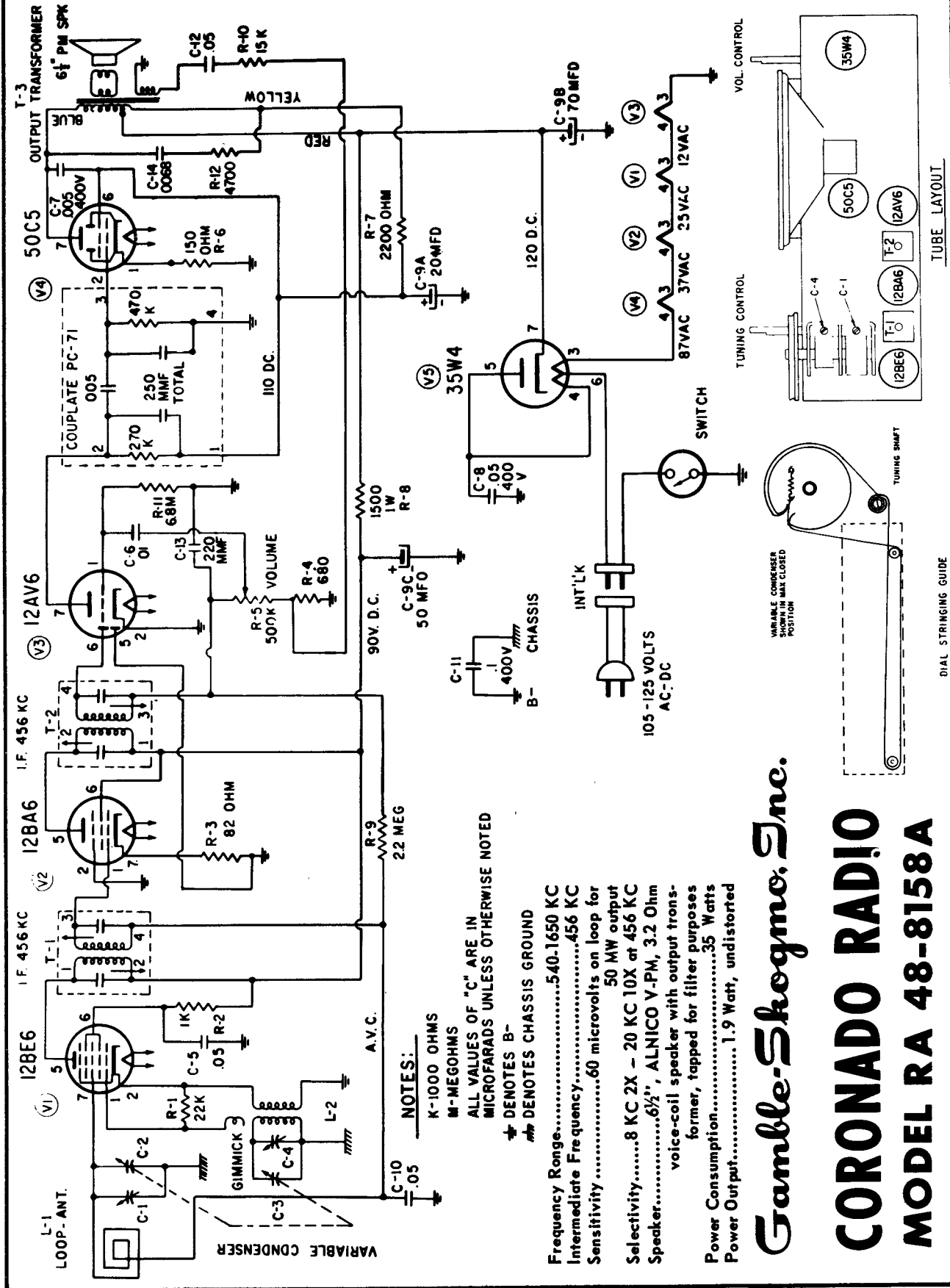



# GENERAL ELECTRIC

Models T105 and T106

## TO REMOVE CHASSIS FROM CABINET

To remove chassis from cabinet, remove cabinet back. Unsolder the output transformer leads from the speaker. Remove the four self-tapping screws, (hex-heads) one on each corner of the chassis, and the single hex screw just below the tuning gang capacitor. Pull off the volume control knob. The tuning control knob is held to the cabinet, so the chassis must be pulled out of the cabinet, at the same time pulling it off the tuning knob, which remains on the cabinet. When pulling out the chassis, it is best to grasp the tuning capacitor (C1) by the thumb and forefinger of one hand, the tuning knob by the other hand and pull.

**CAUTION:** It is important to use extreme care replacing parts and/or soldering on this chassis. Too much heat on the chassis will cause the copper plating to become unbonded. Only apply the soldering iron long enough to melt the solder and pull out the part to be replaced.

## TO REPLACE A TUBE SOCKET

Cut the socket free by cutting all of the socket terminals at the chassis and unsolder the center terminal. Now, heat each terminal only enough to push it out. The new socket can now be inserted into place.

## TO REPLACE THE VOLUME CONTROL

Remove the shaft nut and the fibre washer, then cut the center and lower terminals. Apply only enough heat to the upper terminal to pull out the control. Apply heat to the center and lower terminals so they may be pushed out. The new control may now be inserted into place and soldered. Make sure the fibre washer is in place before installing the shaft nut.

**NOTE:** The shield cans on T1 and T2 can be removed by unfastening the two spring clips and lifting the cans off the transformers, thereby leaving the coils open for inspection or repair.

ALIGNMENT CHART				
STEP	CONNECT TEST OSCILLATOR TO	TEST OSC. SETTING	TUNING GANG SETTING	ADJUST FOR MAX. OUTPUT
I. F. ALIGNMENT				
1	V2, 12BA6 grid (pin 1) in series with .05mf.	455KC		Cores of 2nd. IF xformer T2
2	V1, 12AU6 grid (pin 1) in series with .05mf.	455KC		Cores of 1st I.F. xformer T1
3	Same	455KC		recheck adjustment of T1 and T2
R. F. ALIGNMENT				
4	Inductively coupled to radio loop	1620 KC	Tuning gang open completely	C1D
5		1500 KC	For Maximum Output	C1B

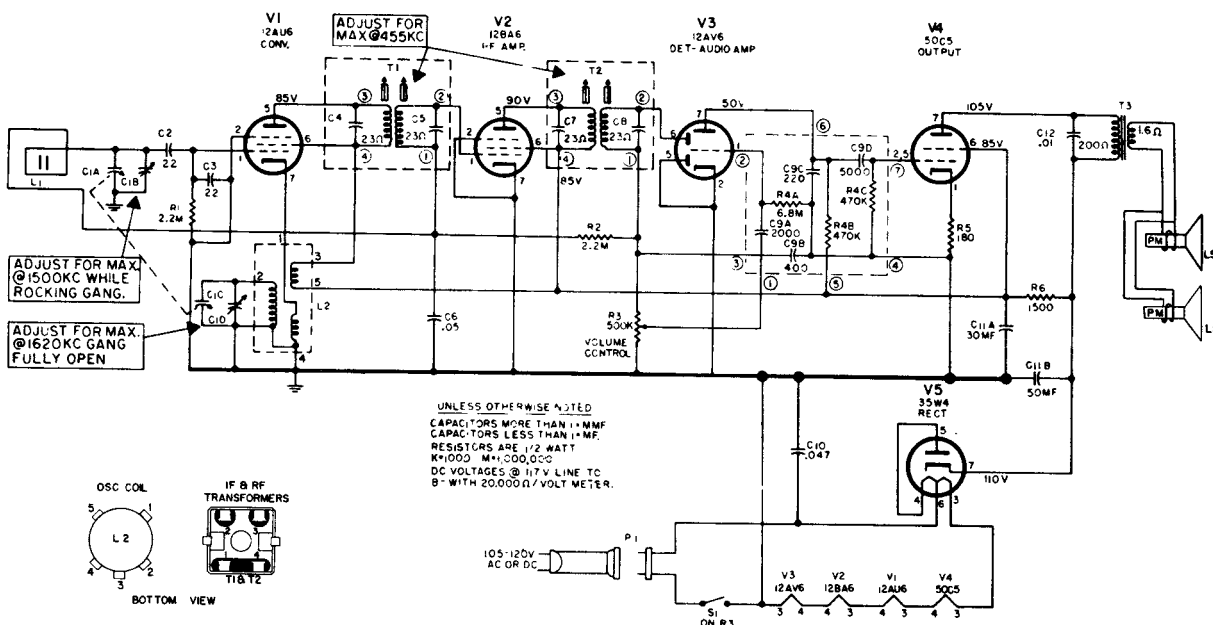

# GENERAL ELECTRIC

Models T115 and T116

### TO REMOVE CHASSIS FROM CABINET

1. Remove the cabinet back by unscrewing the 5 screws.
2. Pull off the three knobs.
3. Remove tone control from bracket.
4. Unsolder the 2 leads which connect the speaker to the chassis.
5. Remove cabinet front by unscrewing the 2 screws on the bottom rail; also the screws on the tone control and volume control brackets.

### TO REMOVE SPEAKERS

1. Remove grille by unscrewing the 4 corner screws on the inside of the cabinet front.
2. Remove the speakers by removing the screws on the front of the speaker.

Label the speaker leads before unsoldering them from the speakers; incorrectly connecting the leads will cause distorted audio.

NOTE: The radio-phonograph switch on the rear of the cabinet should be in the "radio" position before starting alignment procedures.

Always have Volume Control set for maximum, and reduce signal input so AVC will not affect output.

SPECIFICATIONS		
CABINET:	T115, Brown; T116, Ivory	
ELECTRICAL RATING:	Voltage 105-120 Volts AC or DC, 30 Watts	
POWER OUTPUT:	Undistorted	.75 Watts
	Maximum	1.25 Watts
SPEAKERS:	(2) 6 1/2" and 4"; 3.2 ohms @ 400 cps.	
TUBE COMPLEMENT:	V1 R. F. Amplifier	12BA6
	V2 Oscillator-Converter	12BE6
	V3 I. F. Amplifier	12BA6
	V4 Det. & Audio amplifier	12AV6
	V5 Power Output	35C5
	V6 Rectifier	35W4

### ALIGNMENT CHART

Step	Connect Test Oscillator To	Test Oscillator Setting	Receiver Tuning	Adjust for Maximum Output
1	12BA6, V3 grid (pin 1) in series with .05 mf.	455 KC	Minimum capacity	Cores of 2nd i-f transformer T4
2	12BE6, V2 grid (pin 7) in series with .05 mf.			Cores of 1st i-f transformer, T3
3				Recheck adjustment of T4 and T3
4	Inductively coupled to radio loop, L1	1620 KC	Minimum capacity	C1D, oscillator trimmer
5		1500 KC	For Maximum Signal	C1F, r-f trimmer
6				C1B, antenna trimmer
7		Approximately 600 KC	Rock in with core of T1	Core of r-f transformer, T1. Rock in with re-receiver tuning.
8	Repeat steps 4, 5, 6 and 7.			

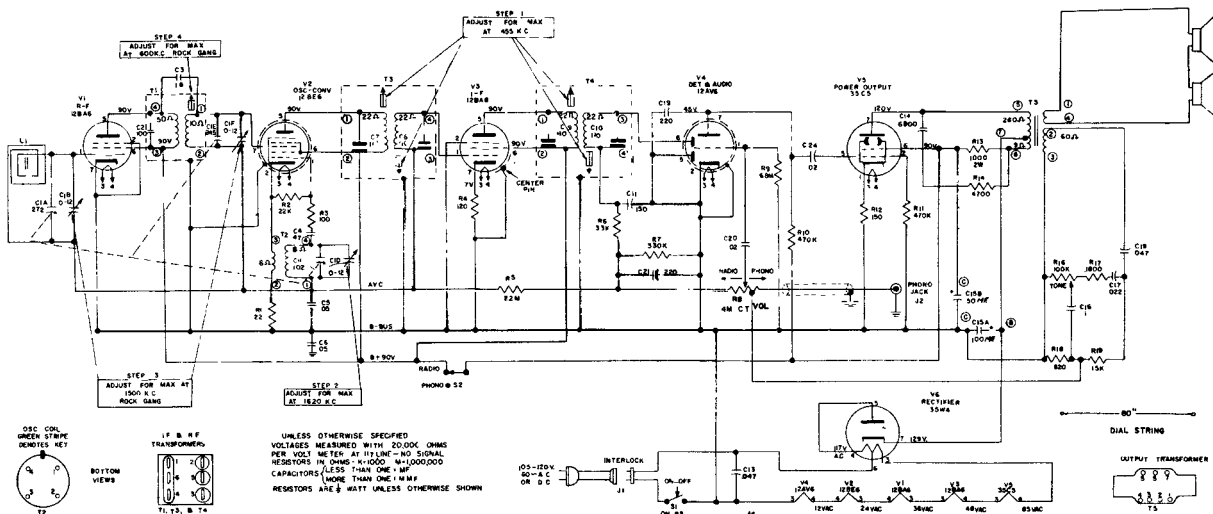

# GENERAL ELECTRIC

MODEL C399

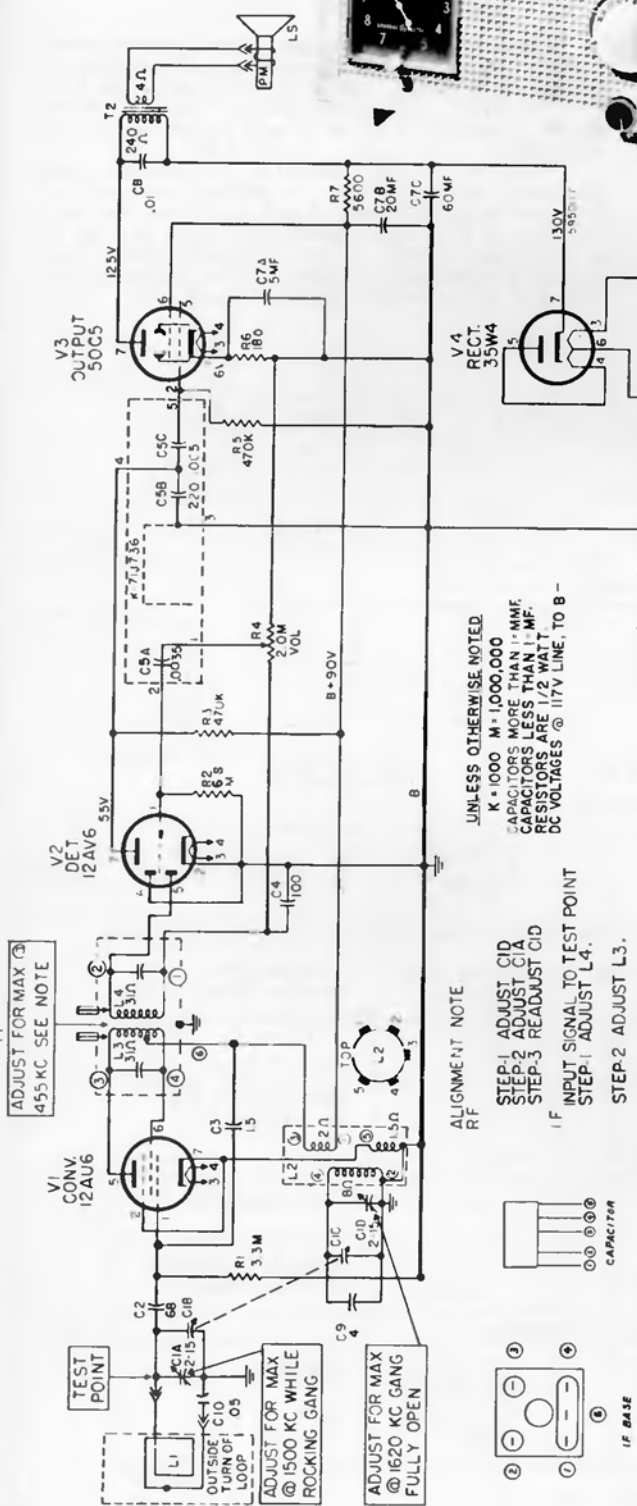
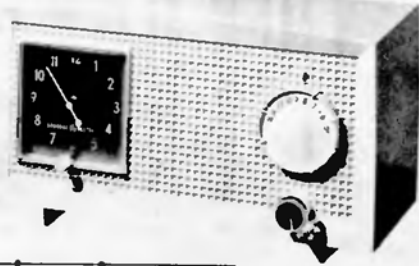

UNLESS OTHERWISE NOTED.  
K = 1000 M = 1,000,000  
CAPACITORS MORE THAN 1.0 MMF.  
RESISTORS LESS THAN 1.0 MF.  
DC VOLTAGES @ 1/2 WATT  
AC VOLTAGES @ 1/2 LINE, TO B -

ALIGNMENT NOTE  
RF  
STEP 1 ADJUST C1A  
STEP 2 ADJUST C1A  
STEP 3 READJUST C1D  
IF INPUT SIGNAL TO TEST POINT  
STEP 1 ADJUST L4.  
STEP 2 ADJUST L3.

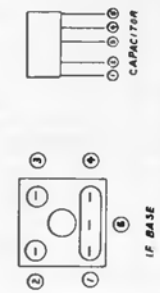

### TO REMOVE CHASSIS FROM CABINET:

Remove cabinet back and interlock. Remove the four self-tapping screws (hex heads), one on each corner of the chassis, and the single hex screw just below the tuning gang capacitor. Pull off the volume control knob. The tuning control knob is attached to the cabinet, so the chassis must be pulled out of the cabinet, at the same time pulling it off the tuning knob, which remains on the cabinet. When pulling out the chassis, first close the tuning capacitor, grasp the capacitor with the thumb and forefinger of one hand and the tuning knob with the other hand and pull.

### TO REPLACE A TUBE SOCKET:

Cut the socket free by cutting all of the socket terminals at the chassis. Now heat each terminal only enough so that the socket may be pushed out. The new socket can now be inserted into the holes left by the old one and soldered into place.

### TO REPLACE THE VOLUME CONTROL:

Remove the shaft nut, then cut the center and lower terminals. Apply only enough heat to the upper terminal to enable you to pull out the control. Apply heat to the center and lower terminals, so they may be pushed out as the new control is inserted into place and soldered.

### COILS AND TRANSFORMERS

RLC-135	L2	Oscillator Coil	1.00
RS-1027	T1	I-F Transformer	1.90
RTO-176	T2	Output Transformer	2.05

### CABINET AND APPEARANCE ITEMS

RB-1000	Cabinet (Yellow)	4.10
RS-1000	Second Hand (Clock)	.05
RS-1005	Knob Clock	.05
RDK-516	Knob, Tuning, Brown	1.25
RDK-425	Knob, Volume, Clear and Gold	.35
RZW-025	Crystal, Clock, Clear	.75
RAB-305	Back and Loop	1.60

### CAPACITORS

CAT. NO.	SYMBOL	DESCRIPTION	PRICE
RCE-217	C7A, B, C	5 mf., @ 25 v., 20 mf., & 60 mf. @ 150 v., electro	\$2.00
RCN-048	C3	1.5 mmf., 20%, 500 v., ceramic	.20
RCN-053	C6	.047 mf., +40 -10%, 600 v., molded	.35
RCT-097	C1A, B, C, D	Tuning capacitor—two gang.	3.40
RCW-3036	C5A, B, C	Bulplate—.0035 mf., 220 mmf., .005 mf	.80
RCW-3079	C4	100 mmf., 20%, 500 v., ceramic	.25
RCW-3186	C8	.01 mf., +40 -10%, 400 v. ....	.30
RCW-3209	C9	4 mmf., ±20%, 500 v., ceramic	.25
UCG-1024	C2	68 mmf., 10%, 500 v.	.35
	C10	.05 mf., 200 v.	

### POTENTIOMETER

RS-1028	R4	Volume Control—2 meg.	1.15
---------	----	-----------------------	------

### RESISTORS

All resistors used in this receiver are common carbon type and are readily obtainable at any Radio Parts Jobber. For values and symbol numbers, refer to the schematic diagram.

# GENERAL ELECTRIC

Models C415, -A, -B, C416, -A, -B, and C417

### TO REMOVE CHASSIS FROM CABINET

1. Remove tuning, volume and timer knobs.
2. Remove time set knob from shaft at back of cabinet. Hold shaft and turn knob counter clockwise.
3. Remove five hex-head screws on cabinet back.
4. Remove four hex-head screws on bottom of cabinet.
5. Remove Snooz-Alarm knob.
6. Remove timer by unscrewing four Phillips head screws.
7. Unsolder speaker leads from speaker.
8. Pull chassis out slowly. Leads from chassis to timer remain attached for A. C. while testing.

### CAUTION

The chassis uses the dip solder copper-plated printed circuit to eliminate most of the inter-connecting wiring. When soldering, keep the heat to a minimum to prevent the printed wiring from becoming unbonded. A 35 to 50 watt soldering iron is recommended.

Always use an isolation transformer when servicing this receiver. To protect the test equipment being used when aligning, connect the output lead of the signal generator to the grid of an I. F. tube through a .05 capacitor. This will prevent the output impedance of the generator from having a loading effect on the circuit.

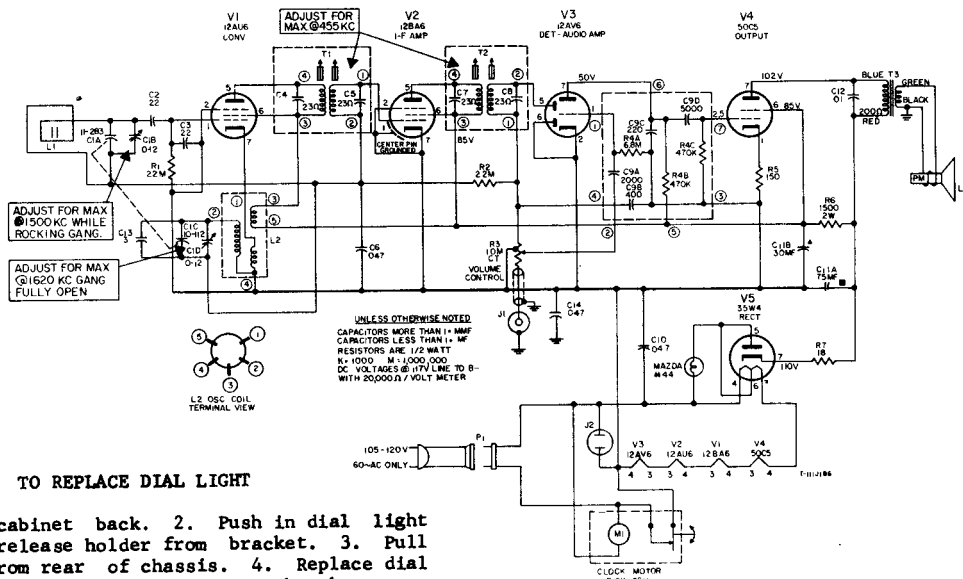

STEP	CONNECT TEST OSCILLATOR TO	TEST OSCILLATOR SETTING	TUNING GANG SETTING	ADJUST FOR MAXIMUM OUTPUT
<b>I. F. ALIGNMENT</b>				
1	V2, 12BA6 grid (pin 1) in series with .05 mfd.			Cores of 2nd I.F. Transformer T2
2	V1, 12AU6 grid (pin 1) in series with .05 mfd.			Cores of 1st I. F. Transformer T1
3				Recheck adjustment of T1 and T2
<b>R. F. ALIGNMENT</b>				
4	Inductively coupled to radio loop	1620 kc	Tuning gang Open	CLD
5		1500 kc	For Maximum Output	CLB*

\* Rock Tuning for maximum while adjusting CLB.

# GENERAL ELECTRIC

Models C420 and C421

### TO REMOVE SPEAKER

1. Follow steps 1 through 5 as above.
2. Remove the 4 hexhead screws from around speaker. This will remove the speaker and speaker grille.

### TO REMOVE CHASSIS

1. Remove volume and tuning knobs.
  2. Unscrew alarm set indicator knob (Rear)
  3. Remove back of cabinet.
  4. Unsolder leads from speaker.
  5. Remove the cabinet top.
5. Remove the cabinet bottom. Timer leads should remain connected, as they are long enough to allow removal of radio for repair.

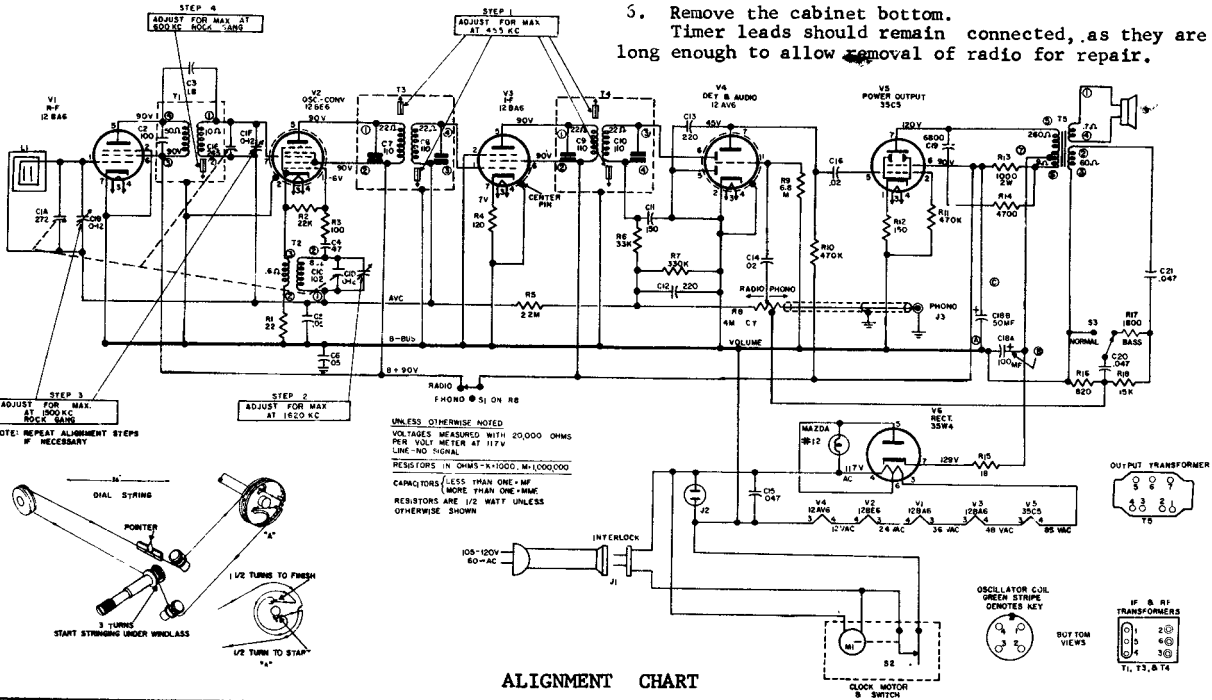

ALIGNMENT CHART

Step	Connect Test Oscillator	Test Oscillator Setting	Receiver Tuning	Adjust for Maximum Output
1.	12BA6, V3 grid (pin 1) in series with a .05 mf.	455KC.	Tuning Gang Open (minimum capacity)	Cores of 2nd I. F. Transformer T4
2.	12BE6, V2 grid (pin 7) in series with a .05 mf.			Cores of 1st I. F. Transformer T3
3.				Recheck adjustment of T3 and T4
4.	Inductively Coupled to Antenna L1	1620 KC	Tuning gang open	C1D Oscillator trimmer
5.		1500 KC	Tune for max. signal	C1F, R.F. Trimmer
6.				C1B, Antenna trimmer
7.		Approximately 600 KC.	Rock in With core Of T1	cores of R. F. Transformer, T1. Rock in with receiver tuning
8.	Repeat Steps 4,5,6,7			

# GENERAL ELECTRIC

Models P710A, -B, -C, -C<sub>1</sub>, and P711A, -B, -C, -C<sub>1</sub>, (Continued on the next page at right)

### TO REMOVE CHASSIS FROM THE CABINET

Pry off the cabinet back by using a small coin in the slots provided on the bottom of the case. Pull off the volume control knob. Remove the tuning knob by unscrewing the thumb screw in its center in a counterclockwise direction; then pull off the large knob. Remove the Phillips flat head screw located under the tuning dial. Also remove the two Phillips head screws located on the speaker end of the chassis. This will enable the chassis to come free from the cabinet front.

This receiver is of dual chassis design. The speaker, loop antenna, volume control, and tuning condenser are mounted on the upper metal chassis. All transistors, transformers, and components are soldered on the etched circuit board.

To separate the metal chassis from circuit board unsolder the two tabs that hold the volume control to the metal chassis; unsolder the lead from the loud-speaker; unsolder the lead from the top lug of the tuning gang oscillator section and two loop leads to the chassis board; carefully bend the two mounting lugs on the speaker end of the circuit board and on the tuning condenser end; also unsolder the lug near the phone jack; then gently pull off the circuit board. The tuning condenser, loop antenna, and speaker will remain on the metal chassis.

### COMPONENT REMOVAL

To remove the speaker from the radio, unsolder one speaker lead and carefully bend over condenser C13 and remove speaker mounting screw.

Remove the tuning condenser by unscrewing the two mounting screws located on the face of the metal chassis.

To replace the volume control, unsolder the three volume control leads at the control and the two switch leads on the back of the control.

### ALIGNMENT

Feed the output from the signal generator to the junction of C2 and the loop antenna for IF alignment. For oscillator and antenna peaking, radiate a signal to the receiver by connecting a ferrite-rod antenna to the signal generator output leads.

All alignment points can be adjusted with the cabinet back off. The I.F. and oscillator cores can be peaked by using the holes provided in the circuit board.

Keep RF from signal generator low.

It is advisable to check battery voltage before alignment to insure a proper operating voltage. Always align the receiver with the batteries in place, as their close proximity to the loop antenna maintains the inductance constant for maximum operating efficiency.

1. Align all IF cores in T1, T2 and T3.
2. With gang fully open align oscillator trimmer C1D to peak at 1620KC.
3. Peak antenna trimmer C1C to maximum output at 1400 KC.
4. Rock oscillator core and gang to peak at 580 KC. Repeat steps 2, 3 and 4 as necessary.

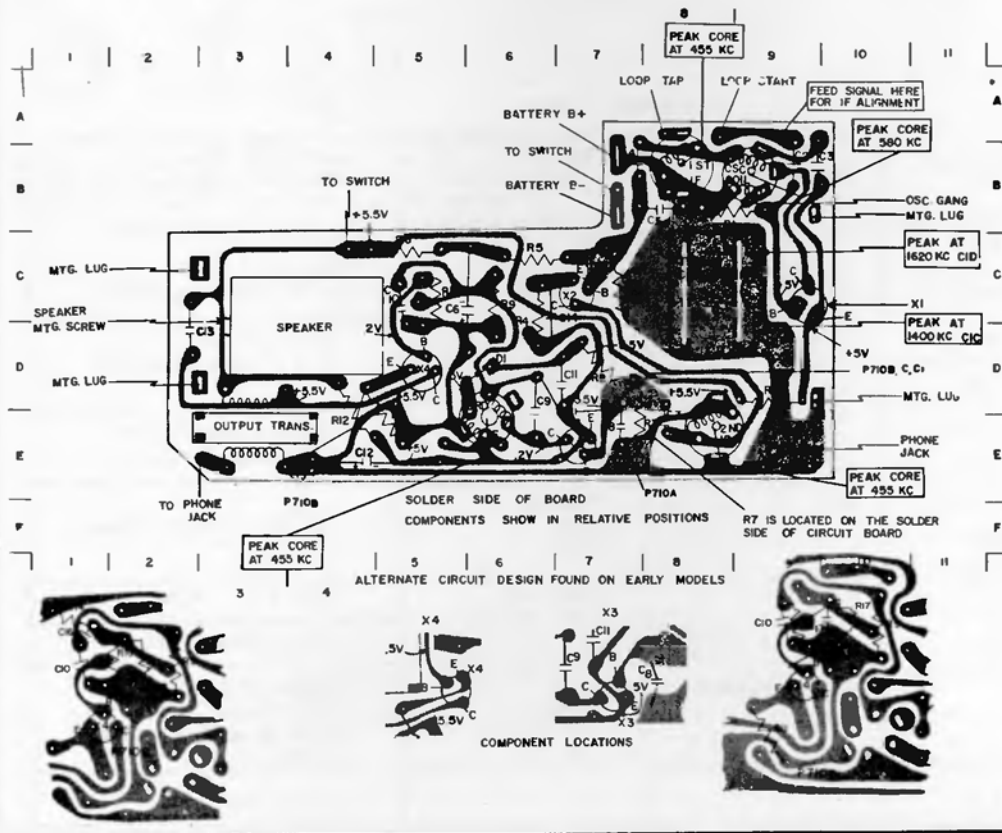

### TRANSISTOR REPLACEMENT

To replace X4, remove the speaker as described above. To remove X2, use needle nose pliers through the hole near the volume control.

# GENERAL ELECTRIC

Models P710A, -B, -C, -C,, and P711A, -B, -C, -C, (Continued from the preceding page)

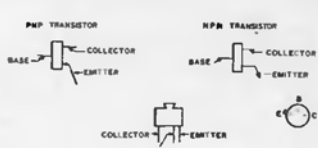
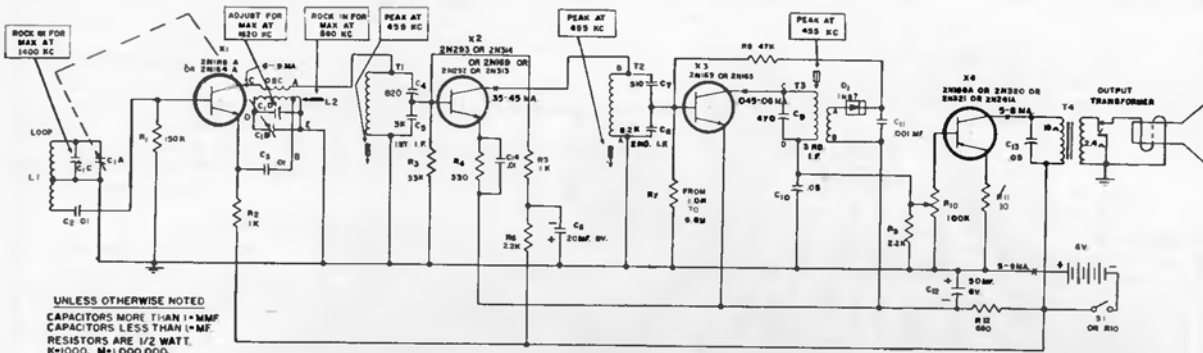

P710A, P711A

### Production Changes

P710B

- C8-- 3000mmf., connected to junction of C9 and C10.
- C15- 50mf., 6V, connected across R11
- R8-- 22K
- R12- 390 ohms
- See Fig. A for X3 and X4 stages.

P710C

- C8-- 3000mmf., connected to junction of C9 and C10.
- C16- 3mf.
- R4-- 120 ohms
- R7-- 1.5 meg
- R8-- 22K
- R12- 390 ohms
- R13- 3.3K
- R14- 18K
- See Fig. B for X3 and X4 stages.

P710C,

- C8-- 3000 mmf., connected to junction of C9 and C10.
- C17- 3mf.
- R8-- 22K
- R17- 4.7K
- R17 and C17 mounted to solder side of component board.
- See Fig. C for X3 and X4 stages.

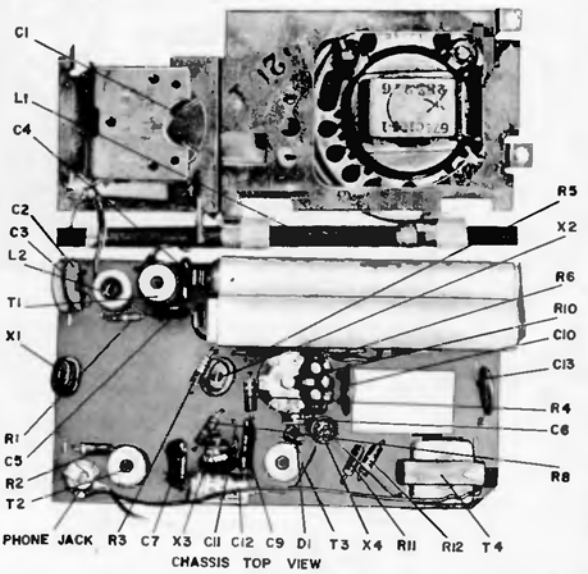
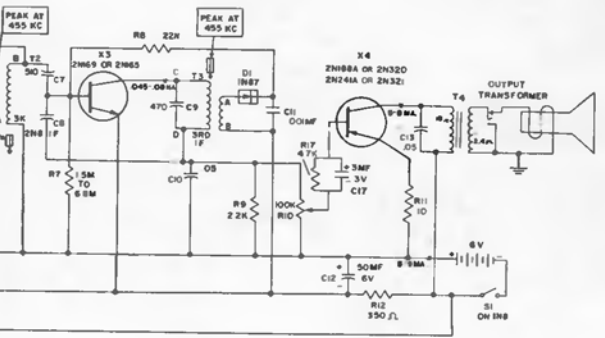
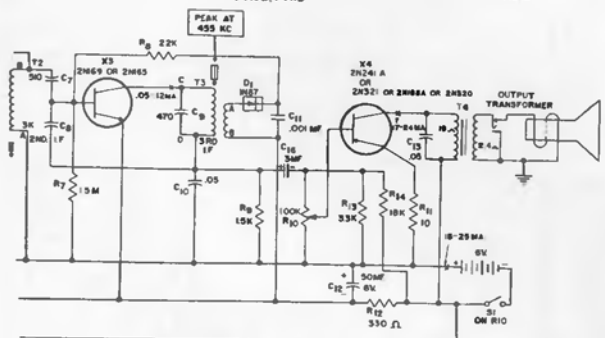
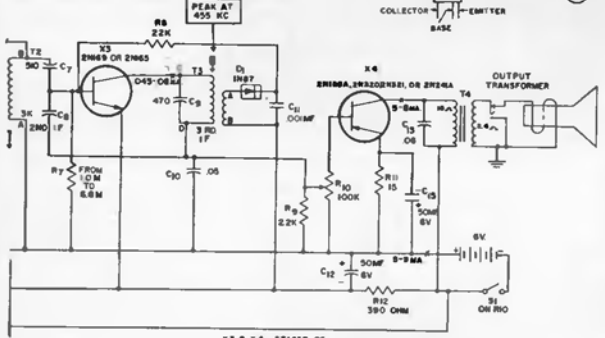

# GENERAL ELECTRIC

Models P725 and P726

## CHASSIS REMOVAL

Remove both knobs. Remove the 4 batteries. Unsolder the two leads on the speaker; unscrew the 5 screws holding chassis to cabinet.

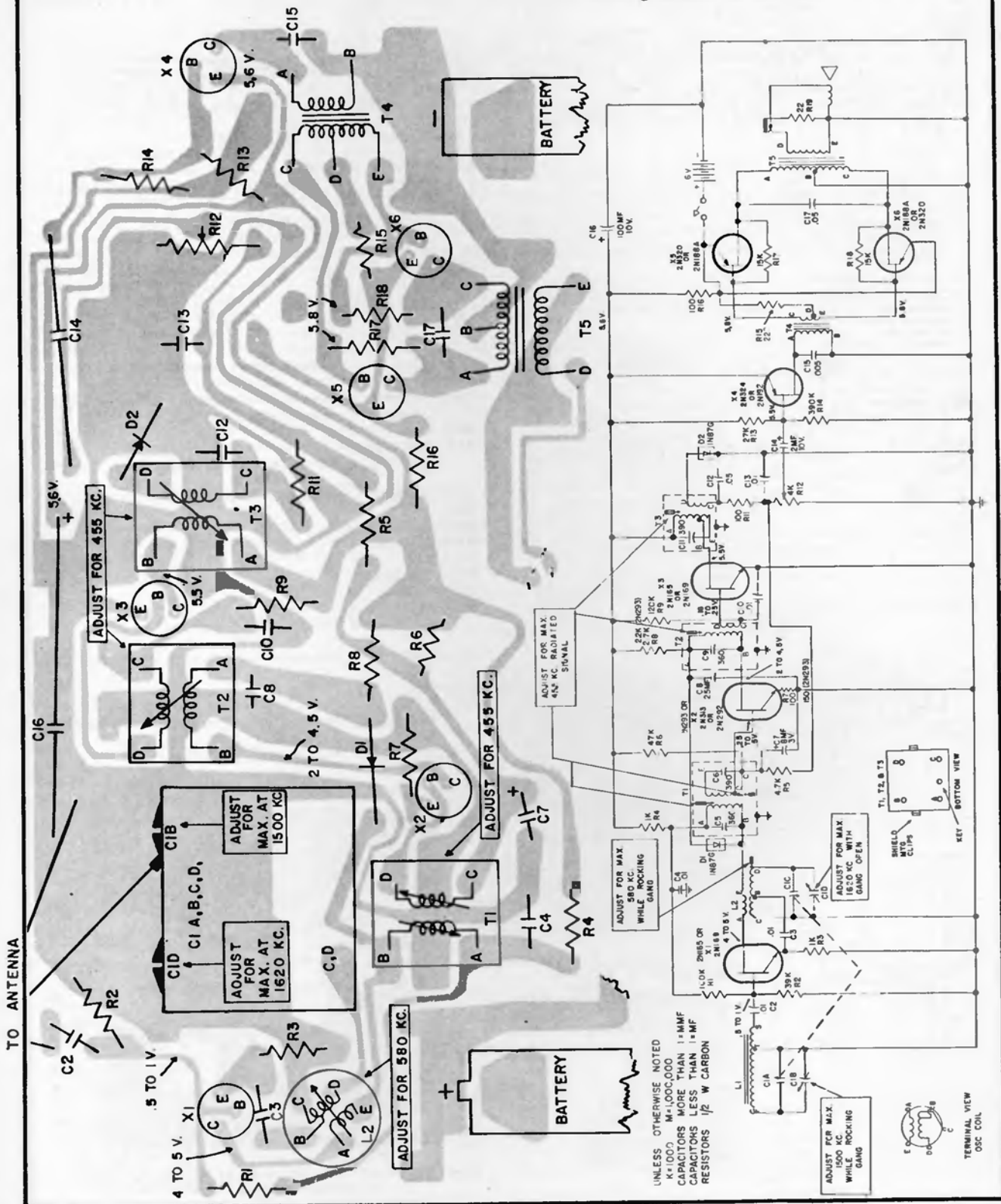



# GENERAL ELECTRIC

Models P745A, P746A

### TO REMOVE CIRCUIT BOARD

1. Remove cabinet back by twisting a coin in the two slots provided along bottom of the cabinet.
2. Remove the four screws that secure the circuit board to cabinet bosses. (SEE COMPONENT WIRING DIAGRAM FOR MOUNTING SCREW POSITIONS).
3. Remove the two screws that secure circuit board to speaker. (SEE COMPONENT WIRING DIAGRAM FOR MOUNTING SCREW POSITIONS).
4. Swing circuit board out of cabinet front. Leave all connecting leads attached to volume control and tuning capacitor.

### TO REMOVE TUNING CAPACITOR

1. Follow steps 1 and 2 as above.
2. Remove tuning knob by unscrewing the thumbscrew in its center in a counterclockwise direction.
3. Remove the flat head screws located under tuning knob.

### TO REMOVE VOLUME CONTROL

1. Follow steps 1 through 3 as above.
2. Remove on-off volume knob by unscrewing the screw in the center of the knob.
3. Remove hex nut from volume control shaft.
4. Move tuning capacitor slightly and lift out volume control.

### TROUBLESHOOTING

A check of the battery condition and total current drain of the receiver should be made first. All current measurements are made at quiescence with the receiver turned on, volume control at maximum, tuning gang closed, and with no signal conditions.

### CAPACITORS

RS-1378	CA, B, C, D	Tuning Capacitor.....
RS-1022	C1, 3	.01mf., 450V.....
	C2, 7	.01mf., 50V.....
	C4	150mmf., 300V.....
RS-1462	C5	8mf., 6V.....
	C6, 9	390mmf., 300V.....
RS-1024	C10, 17, 19	.05mf., 50V.....
	C18	.003mf., 100V.....
RS1453	C16	32mf., 6V.....
RS-1460	C11, 12, 14, 15	3mf., 6V.....

The total receiver current drain is 15 to 20 mls. This is measured by inserting a milliammeter in series with the batteries.

If an excessive total current drain is recorded, the individual collector current readings of each transistor should be checked. An excessive current reading may mean a shorted transistor; no current will indicate that a transistor or associated circuit components are defective.

A single-edge razor blade is a satisfactory tool for cutting the copper circuit wiring, so that a milliammeter can be inserted in series with the break to measure the current flow. After each current check is completed, solder the cut carefully to complete the circuit again.

### NO RECEPTION:

1. Check battery voltage and battery contacts.
2. Check on-off switch.
3. Check all antenna lead connections.
4. Check coil L2.

### WEAK AUDIO:

1. Check battery voltage for 4.5 volts.
2. Check battery current.
3. Check transistor collector currents.
4. Check alignment.

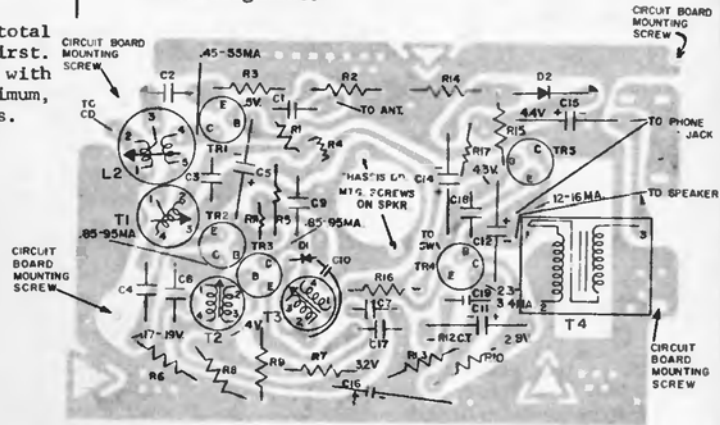

COMPONENT WIRING DIAGRAM

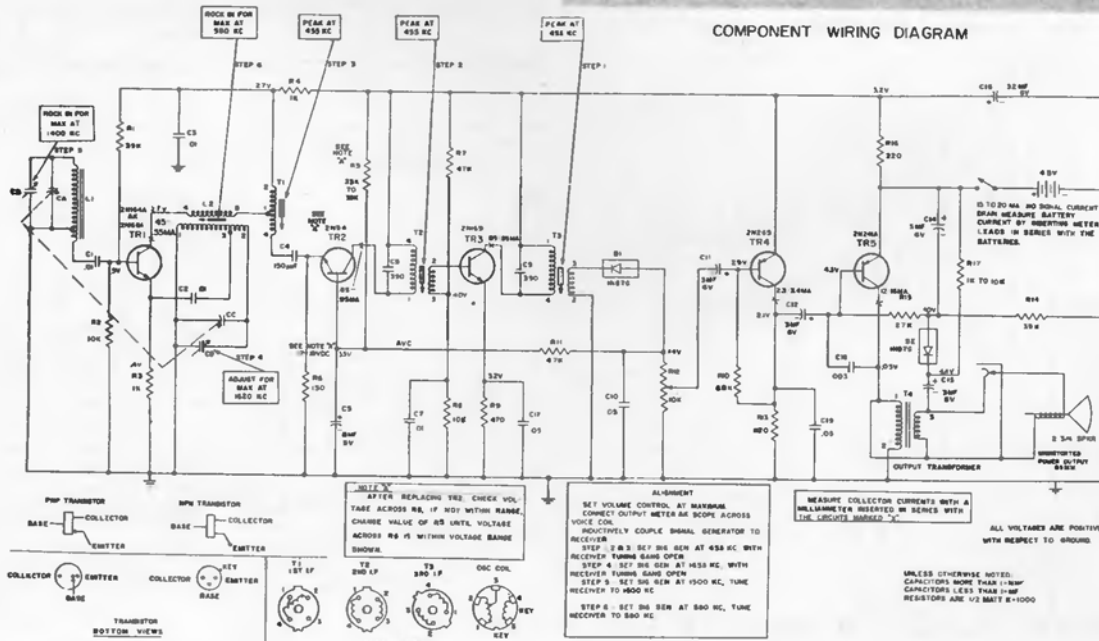

GENERAL ELECTRIC Model P750A

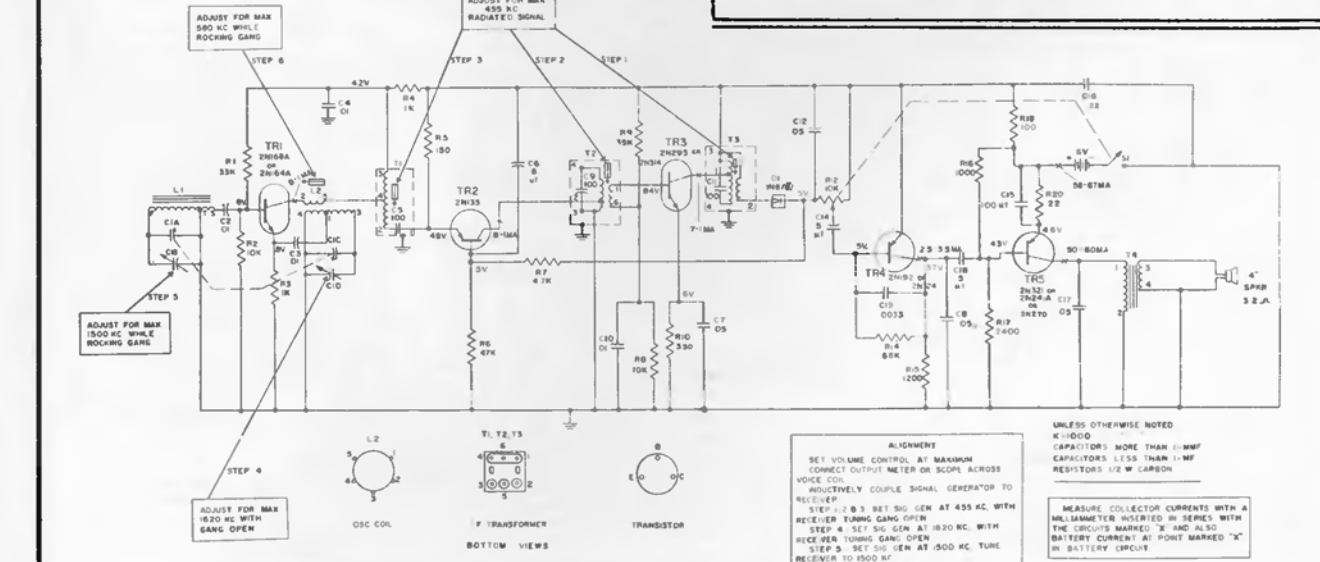
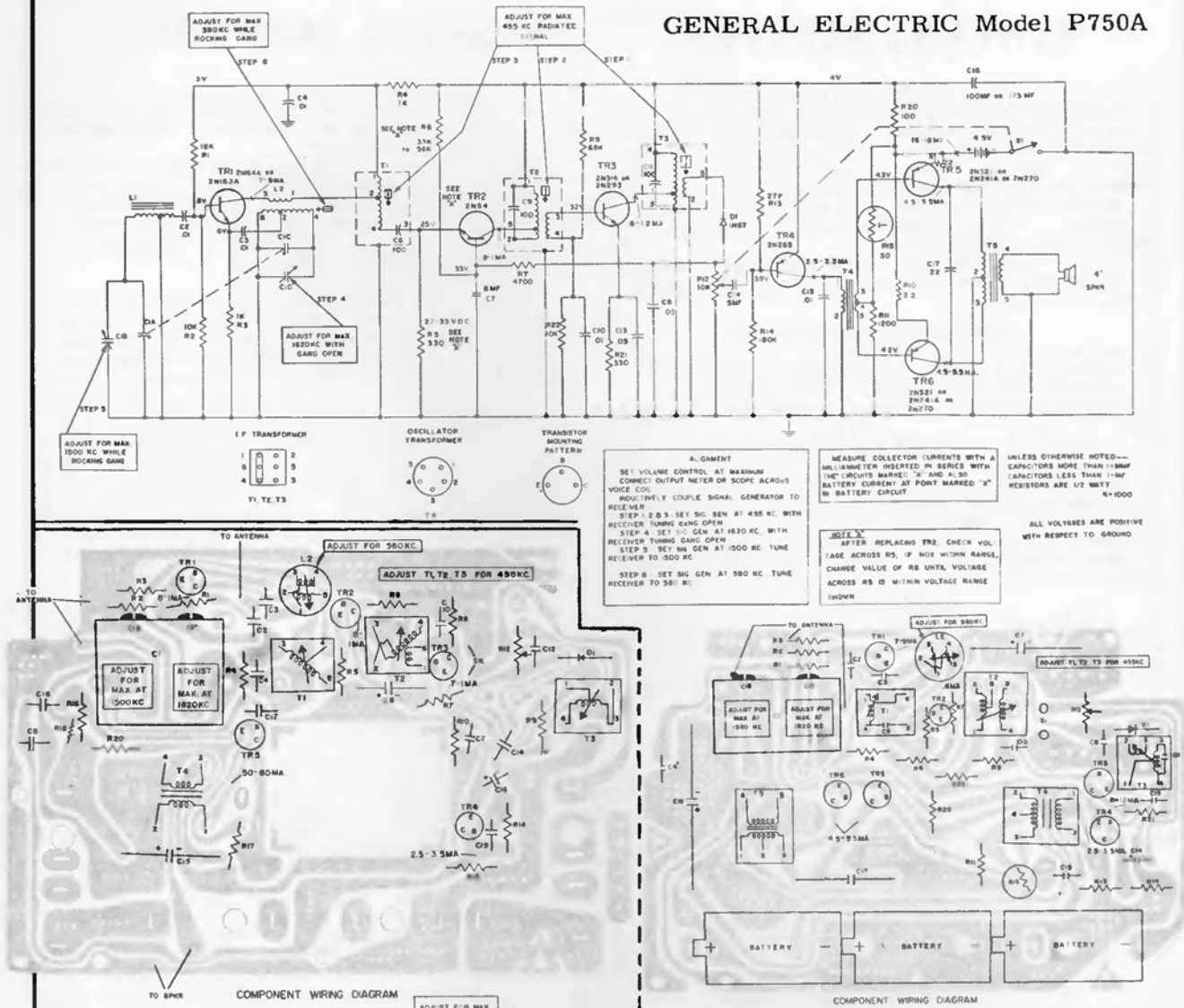

GENERAL ELECTRIC Models P760A, P761A

# GENERAL ELECTRIC

Models P765A, -B, and P766A, -B

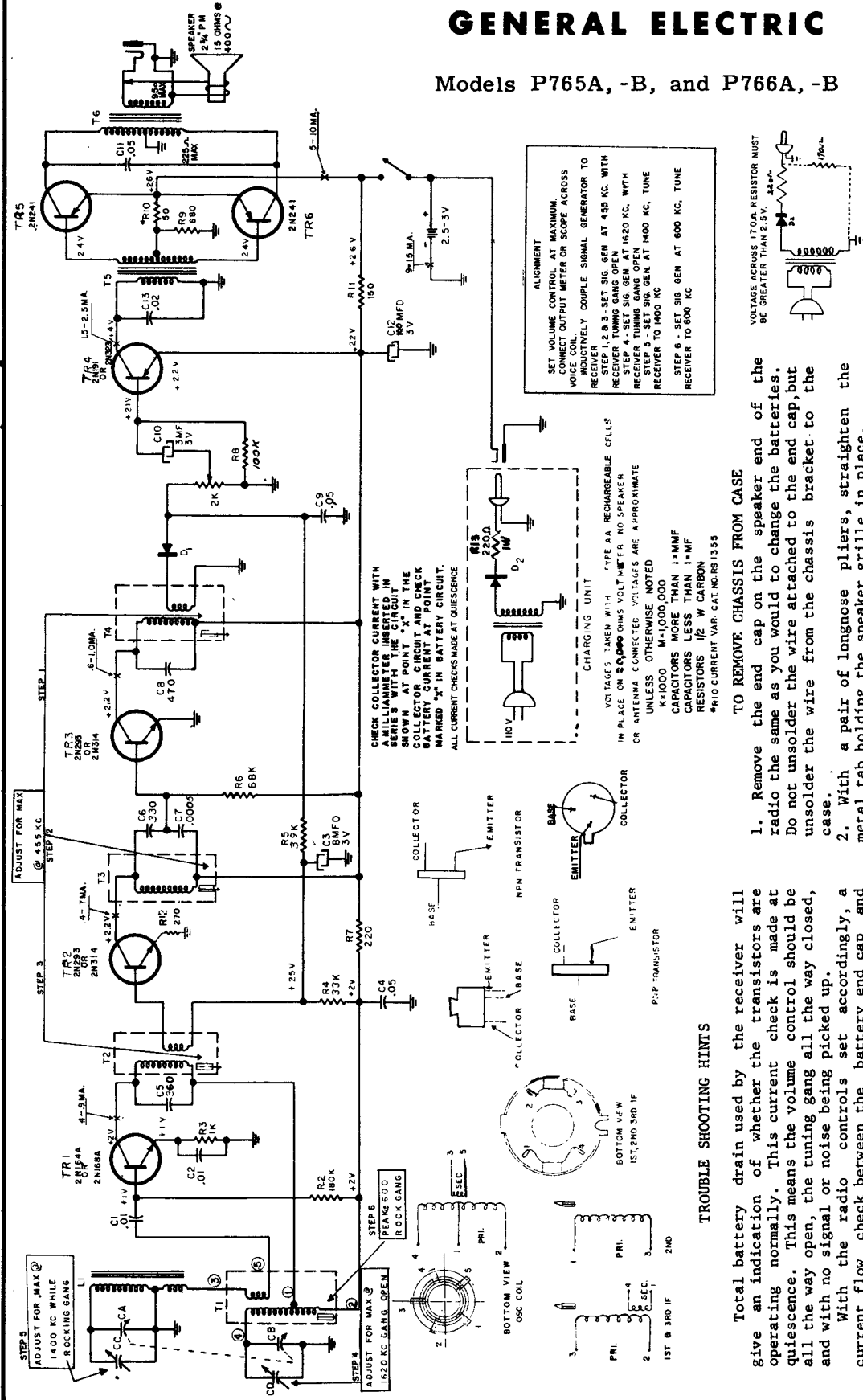

MONTGOMERY WARD Transistor Radio Model BR-1102A

TYPE 2N109, 2N139 AND 2N140

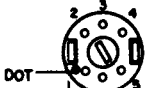

TRANSISTOR SOCKET

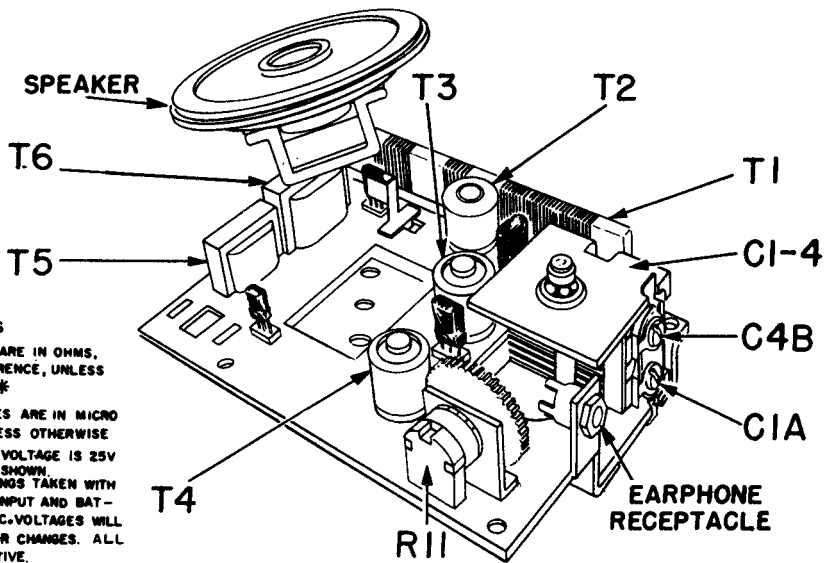
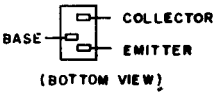

NOTES

RESISTOR VALUES ARE IN OHMS, 1/4 WATT, 10% TOLERANCE, UNLESS OTHERWISE SHOWN. \*  
 CAPACITOR VALUES ARE IN MICRO-MICROFARADS, UNLESS OTHERWISE SHOWN. DC WORKING VOLTAGE IS 25V UNLESS OTHERWISE SHOWN. DC VOLTAGE READINGS TAKEN WITH VTVM, NO SIGNAL IN INPUT AND BATTERY VOLTAGE - 9VDC. VOLTAGES WILL VARY WITH TRANSISTOR CHANGES. ALL VOLTAGES ARE NEGATIVE.

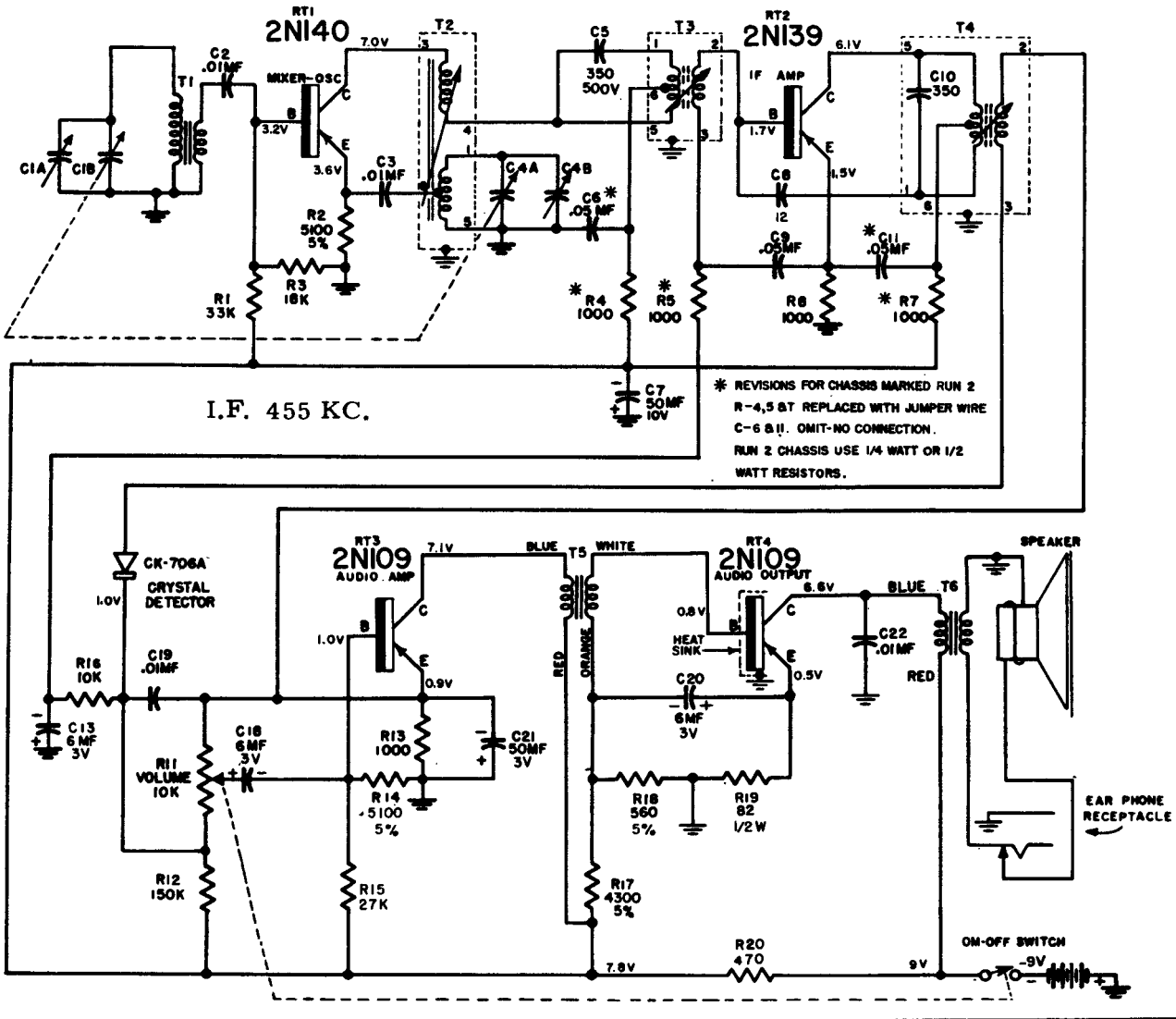

\* REVISIONS FOR CHASSIS MARKED RUN 2  
 R-4,5 BT REPLACED WITH JUMPER WIRE  
 C-6 & 11 OMIT-NO CONNECTION.  
 RUN 2 CHASSIS USE 1/4 WATT OR 1/2 WATT RESISTORS.

MONTGOMERY WARD  
Models BR-1557B, BR-1558B

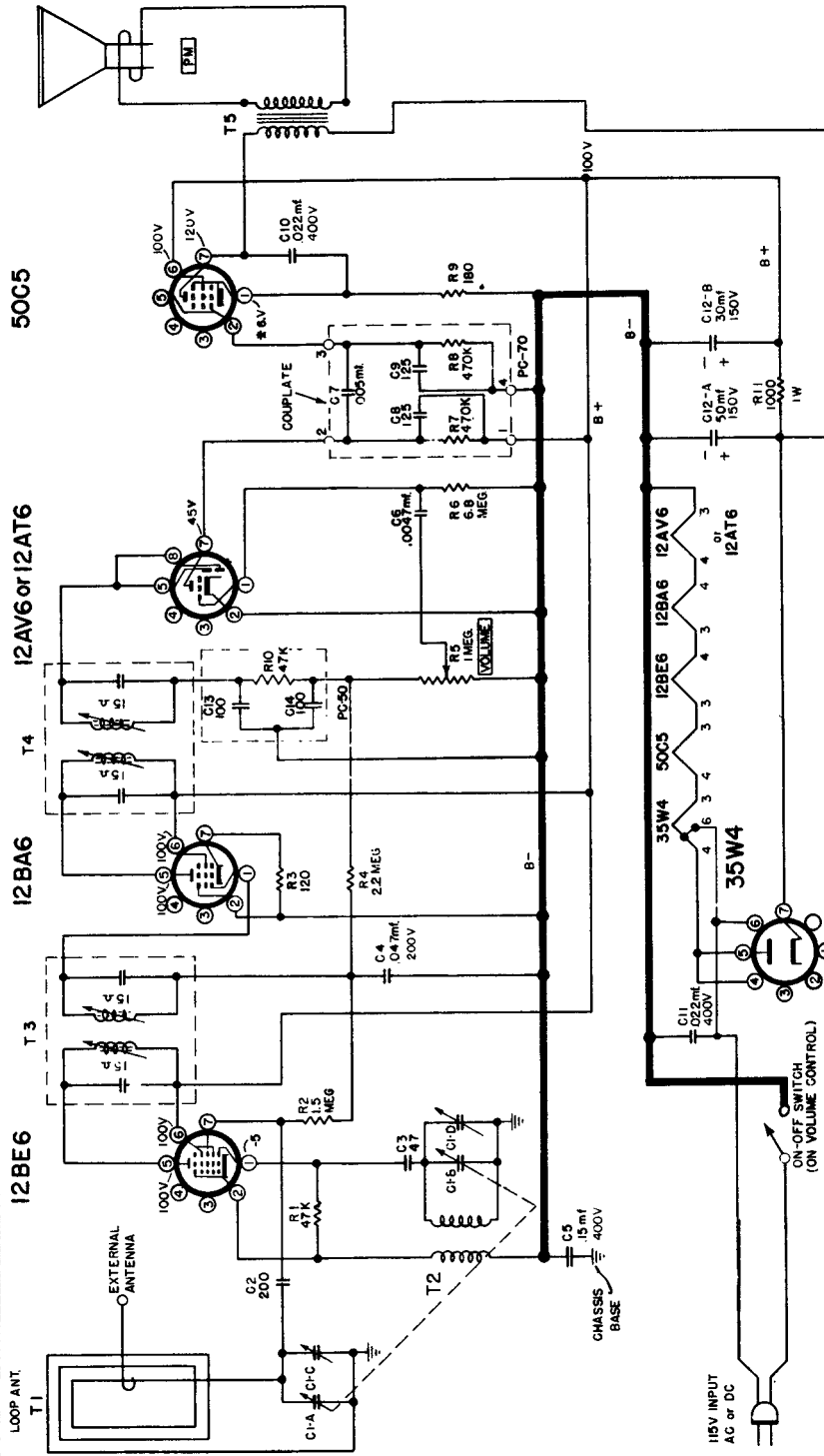

NOTES:  
VOLTAGE READINGS TAKEN WITH A 1000-OHM-PER-VOLT  
VOLTMETER ON THE 250 VOLT SCALE  
\*READ ON THE 10 VOLT SCALE OF THE VOLTMETER  
LINE INDICATES OTHERWISE SHOWN, RESISTOR VALUES ARE IN OHMS  
AND ARE 1/2 WATT  
CAPACITOR VALUES ARE IN MICRO-MICROFARADS

ALIGNMENT PROCEDURE

FREQUENCY	SIGNAL GENERATOR		GROUND SIDE	TUNER SETTING	ADJUST FOR MAXIMUM OUTPUT
	COUPLING CAPACITY	CONNECTION TO RADIO			
I.F.	485 KC	.1 mfd.	SHELL OF LYTIC	GANG OPEN (plates out of mesh)	Top and Bottom cores T4 and T3
Osc.	1620 KC	.1 mfd.	SHELL OF LYTIC	GANG OPEN (plates out of mesh)	CIF Osc. trimmer on gang
Ant.	1400 KC	Connect 3 turn loop generator place near loop on receiver		TUNE TO (1400 KC signal)	C1E Antenna trimmer on gang

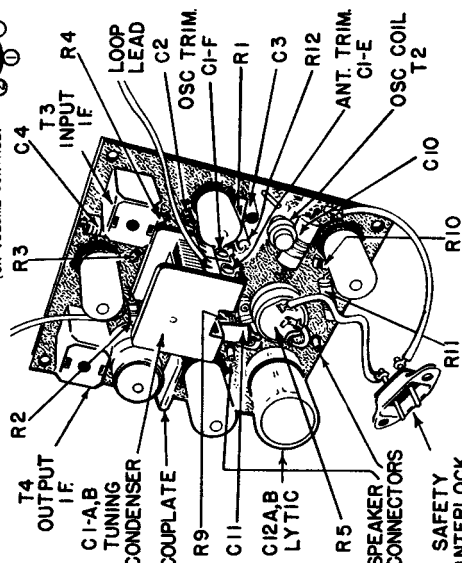

CHECK FOR ALIGNMENT AND DIAL CALIBRATION AT 1000 AND 600 KC.

## MONTGOMERY WARD

### Models HA-1645A, HA-1646A

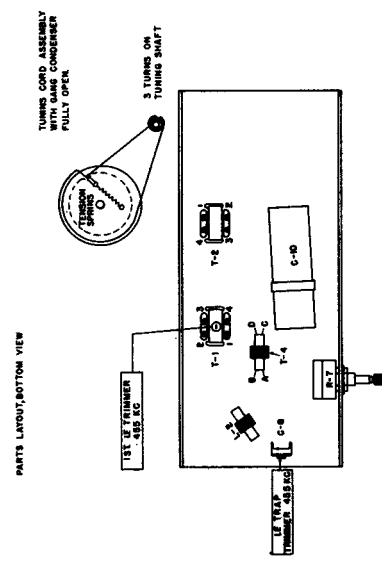
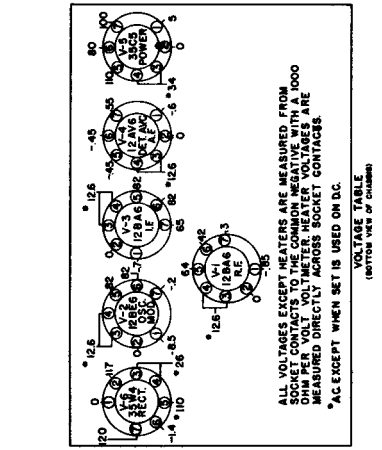
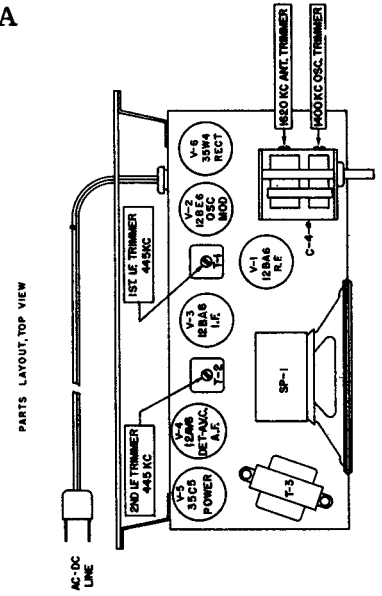
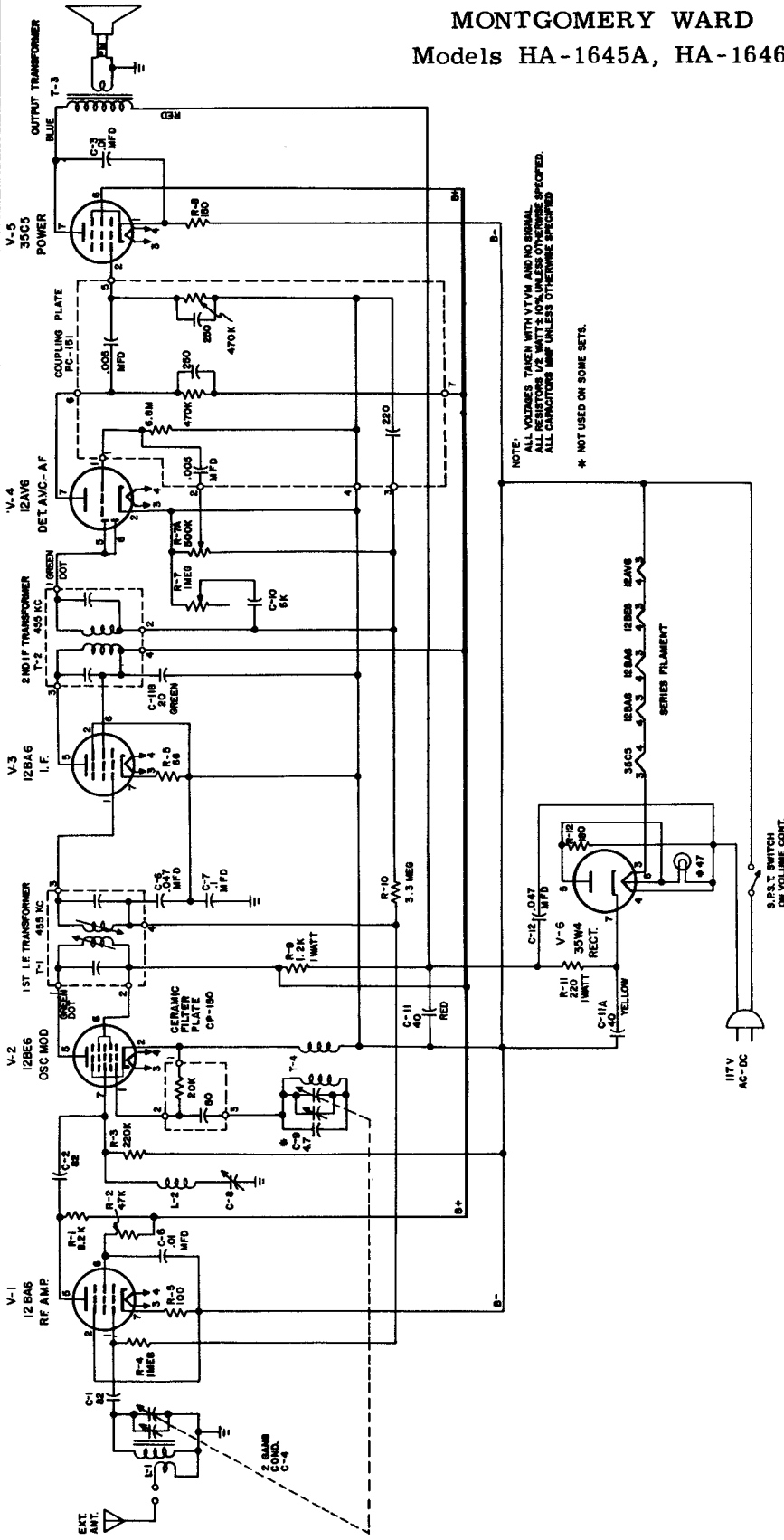

# MOTOROLA

**AUTO RADIO  
MODEL  
7MX**

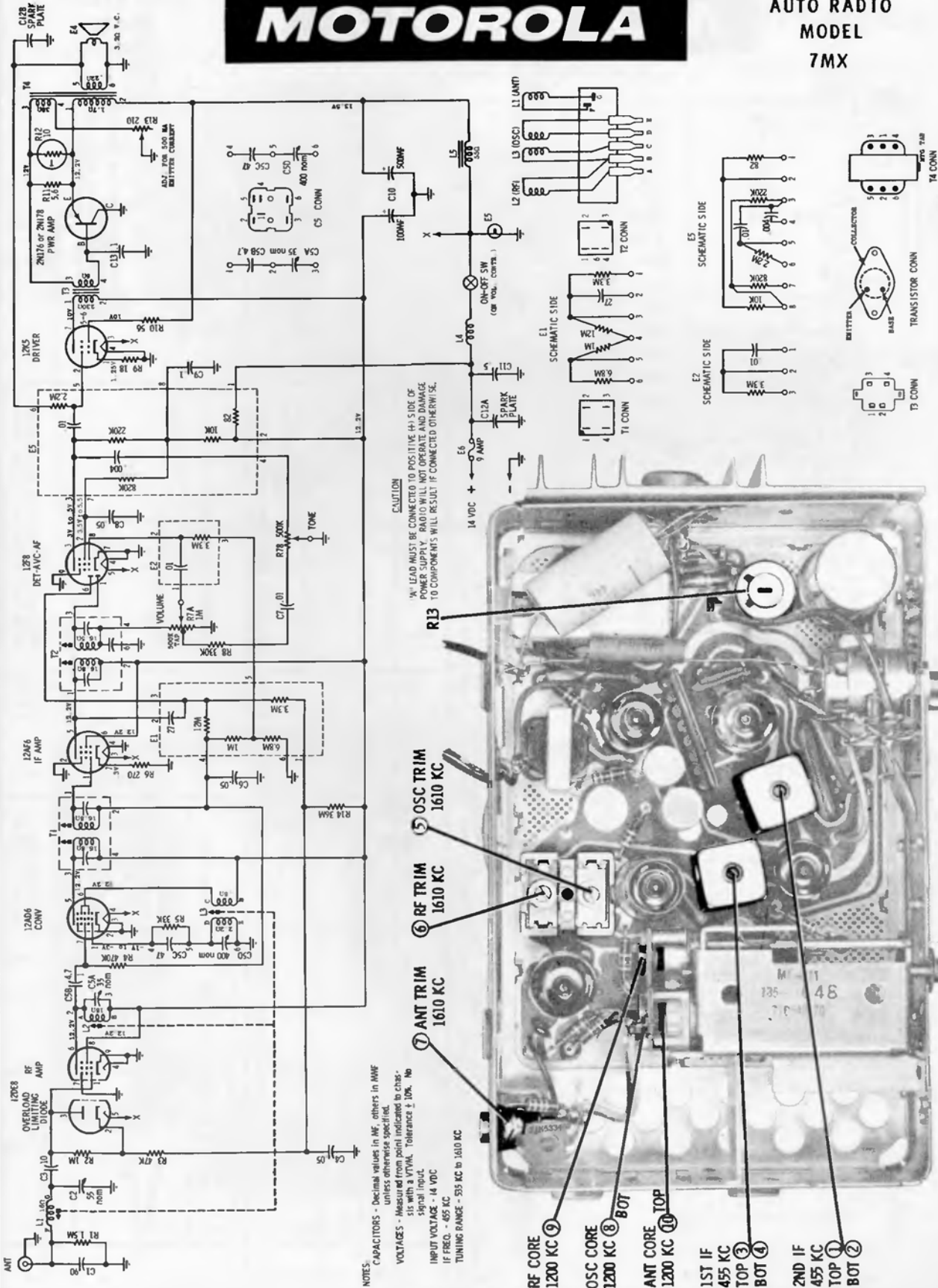

# MOTOROLA

(Continued on page 81)

**AUTO RADIO  
MODEL  
CTM7X**

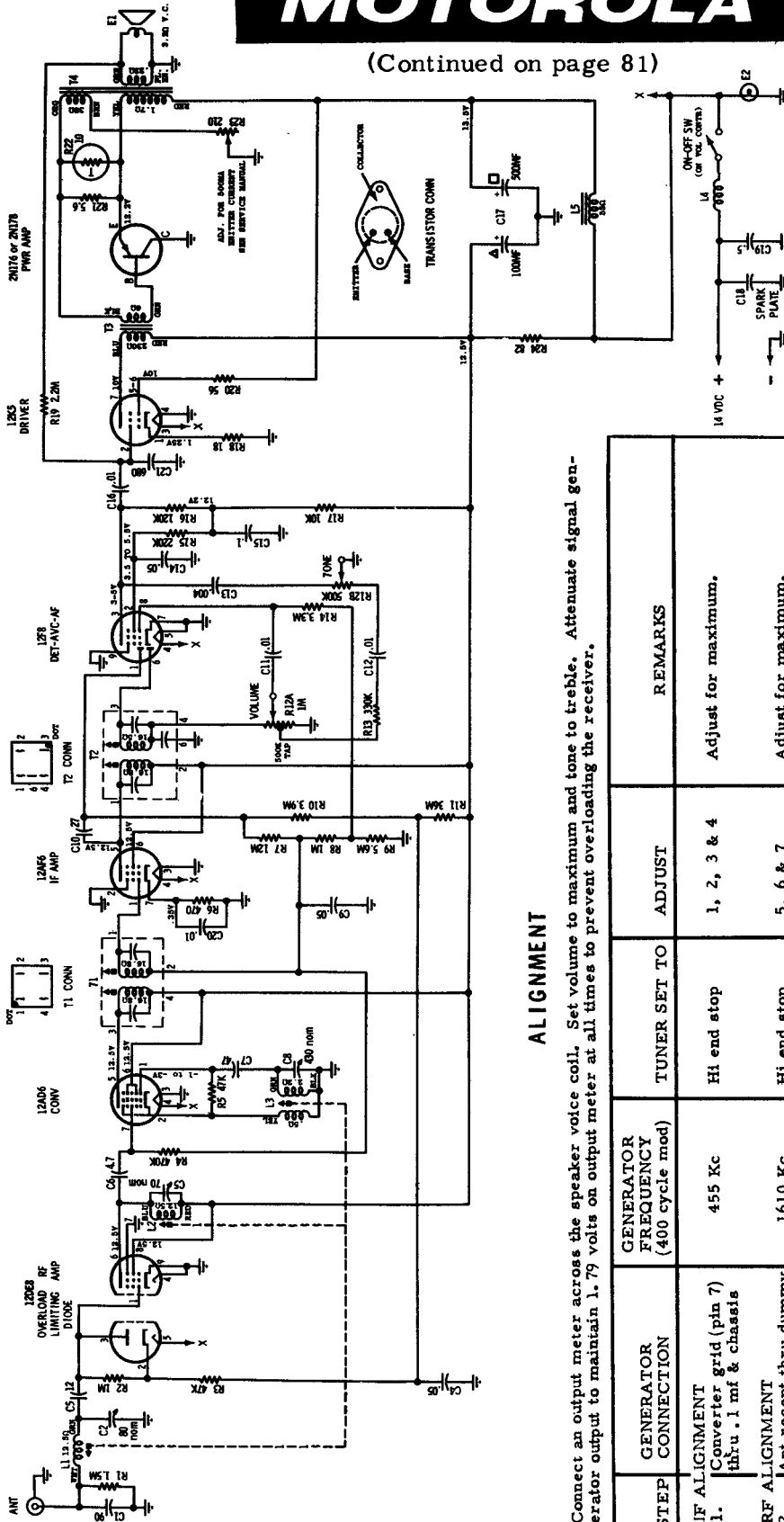

**CAUTION**  
"M" LEAD MUST BE CONNECTED TO POSITIVE (+) SIDE OF POWER SUPPLY. RADIO WILL NOT OPERATE AND DAMAGE TO COMPONENTS WILL RESULT IF CONNECTED OTHERWISE.

**NOTES:**  
CAPACITORS - Decimal values in MF, others in MUF unless otherwise specified.  
VOLTAGES - Measured from point indicated to chassis with a VTVM. Tolerance  $\pm 10\%$ . No signal input.  
INPUT VOLTAGE - 14 VDC.  
TUNING RANGE - 295 KC to 1605 KC.  
IF FREQ. - 455 KC.

## ALIGNMENT

Connect an output meter across the speaker voice coil. Set volume to maximum and tone to treble. Attenuate signal generator output to maintain 1.79 volts on output meter at all times to prevent overloading the receiver.

STEP	GENERATOR CONNECTION	GENERATOR FREQUENCY (400 cycle mod)	TUNER SET TO	ADJUST	REMARKS
1.	IF ALIGNMENT Converter grid (pin 7) thru .1 mf & chassis	455 Kc	Hi end stop	1, 2, 3 & 4	Adjust for maximum.
2.	RF ALIGNMENT Ant recept thru dummy (see Fig.)	1610 Kc	Hi end stop	5, 6 & 7	Adjust for maximum.
3.	Ant recept thru dummy (see Fig.)	1610 Kc	Hi end stop	5, 6 & 7	Adjust for maximum.
4.	"	1400 Kc	Tuner carriage 13/64" from Hi end stop	8, 9 & 10	Adjust for maximum.
5.	"	1610 Kc	Hi end stop	5, 6 & 7	Adjust for maximum.
6.	Repeat steps 4 & 5 until no further increase, then cement tuning cores in place; step 5 should be last adjustment.				
7.	ANTENNA TRIMMER	-	Weak station around 1400 Kc	7	With radio installed in car and antenna fully extended, adjust antenna trimmer for maximum.

(See page 81 for views of locations of adjustments and parts)



**MOTOROLA**

Model CTM7X

(Continued from page 80)

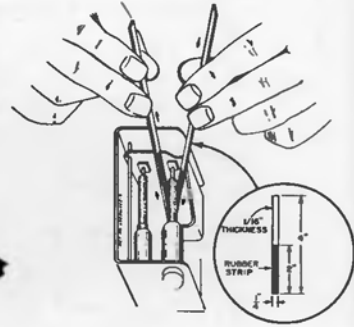
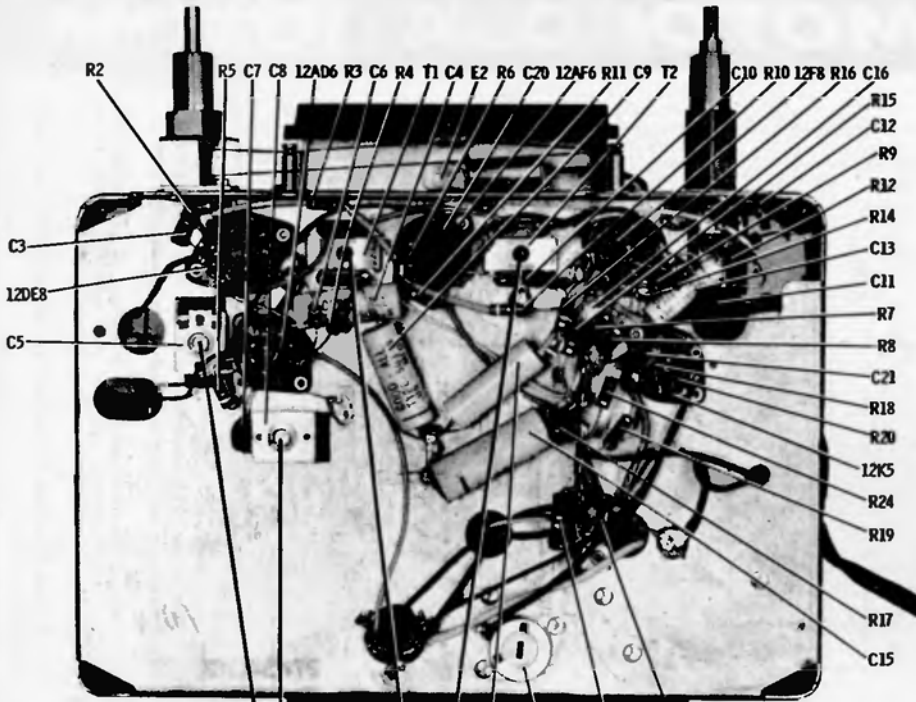

CORE ALIGNMENT TOOL DETAIL

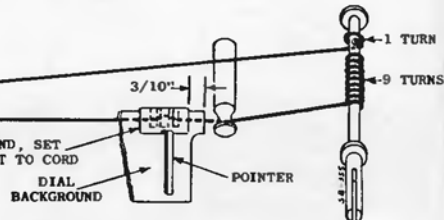
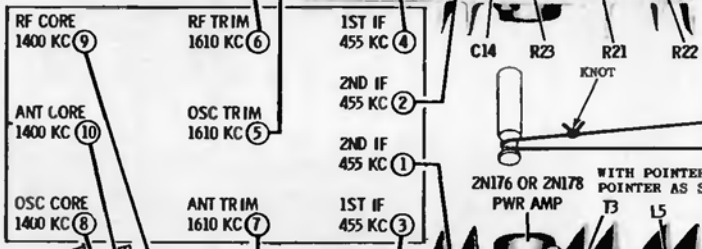

DIAL RESTRINGING DETAIL

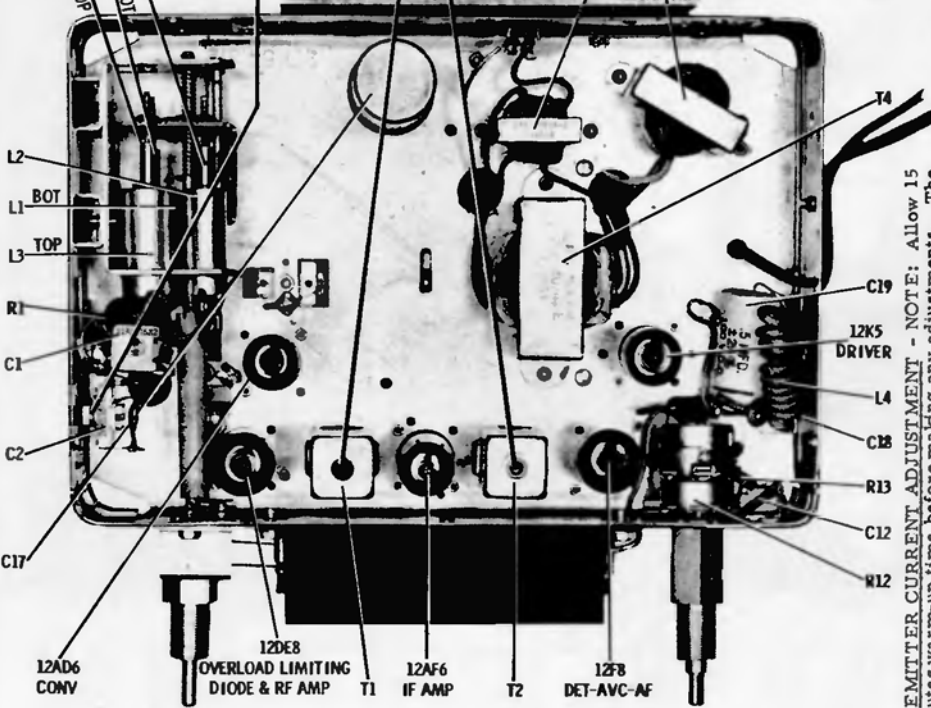

ALIGNMENT ADJUSTMENTS & PARTS LOCATIONS

**EMITTER CURRENT ADJUSTMENT - NOTE:** Allow 15 minutes warm-up time before making any adjustments. The emitter current is adjusted by variable resistor R-23 for a 500 Ma flow through the transistor with 14 volts at the receiver's "A" lead. Disconnect yellow lead which goes to the emitter contact of the transistor socket; connect this lead to the positive side of a milliammeter; connect negative side of meter to emitter contact of the transistor socket. Adjust variable resistor R-23 for a 500 Ma current flow through the meter. NOTE: INTERNAL RESISTANCE OF MILLIAMMETER SHOULD NOT EXCEED .5 OHM.

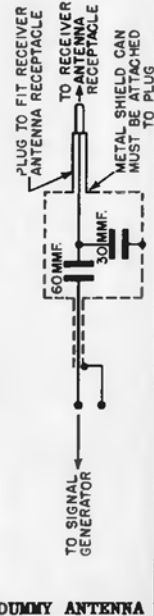

DUMMY ANTENNA

# MOTOROLA

## AUTO RADIO MODEL 0EA7X

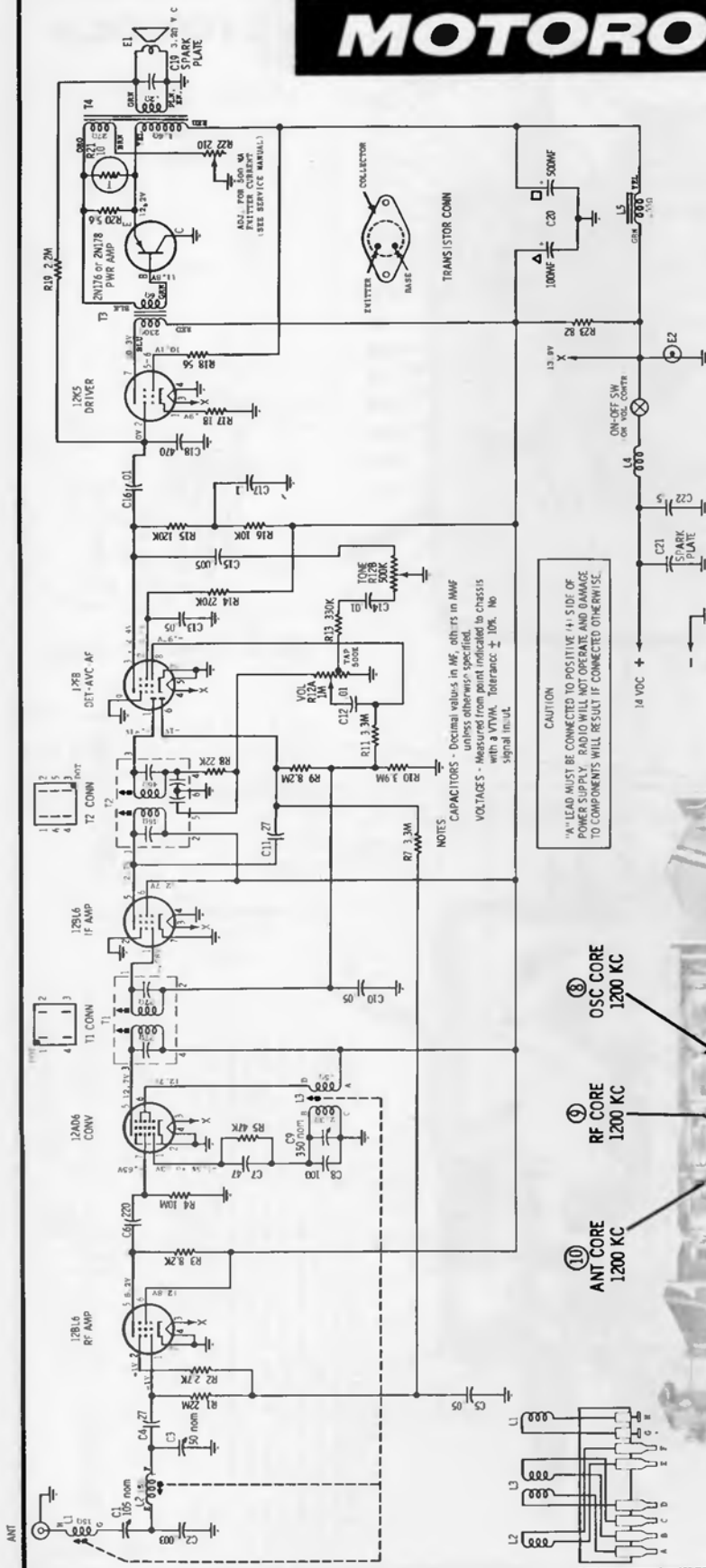

**CAUTION**  
"A" LEAD MUST BE CONNECTED TO POSITIVE (+) SIDE OF POWER SUPPLY. RADIO WILL NOT OPERATE AND DAMAGE TO COMPONENTS WILL RESULT IF CONNECTED OTHERWISE.

**NOTES**  
CAPACITORS - Decimal values in MF, others in MMF unless otherwise specified.  
VOLTAGES - Measured from point indicated to chassis with a VTVM. Tolerance: ± 10%. No signal input.

### TO SET PUSHBUTTONS

- To set the pushbuttons for automatic tuning, proceed as follows:
1. Tune in the desired station with the manual tuning knob. Tune carefully until you are exactly on the station.
  2. Pull out the first pushbutton to be set, to unlock the button for station set-up, and then push button in firmly to set and lock the pushbutton.
  3. Follow the above procedure for the remaining four pushbuttons.

- ⑩ ANT CORE 1200 KC
- ⑨ RF CORE 1200 KC
- ⑧ OSC CORE 1200 KC



# MOTOROLA

## AUTO RADIO MODEL VWA7

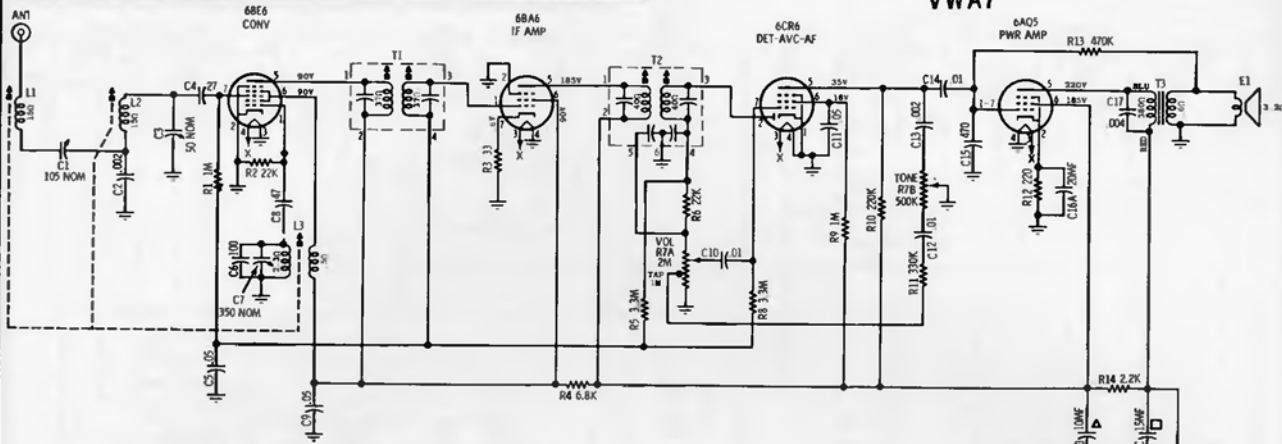

TYPE - Automotive type superheterodyne receiver designed for custom installation in the 1957, 1956, 1955, 1954 & 1953 Volkswagen cars.

NOTES:  
CAPACITORS: Decimal values in MF, all others in MUF unless otherwise specified.  
VOLTAGES: Measured from point indicated to chassis with a VTVM. No signal input.  
Tolerance  $\pm 10\%$ .  
INPUT VOLTAGE: 7V  
TUNING RANGE: 535 KC to 1605 KC.  
IF: 262.5 KC.

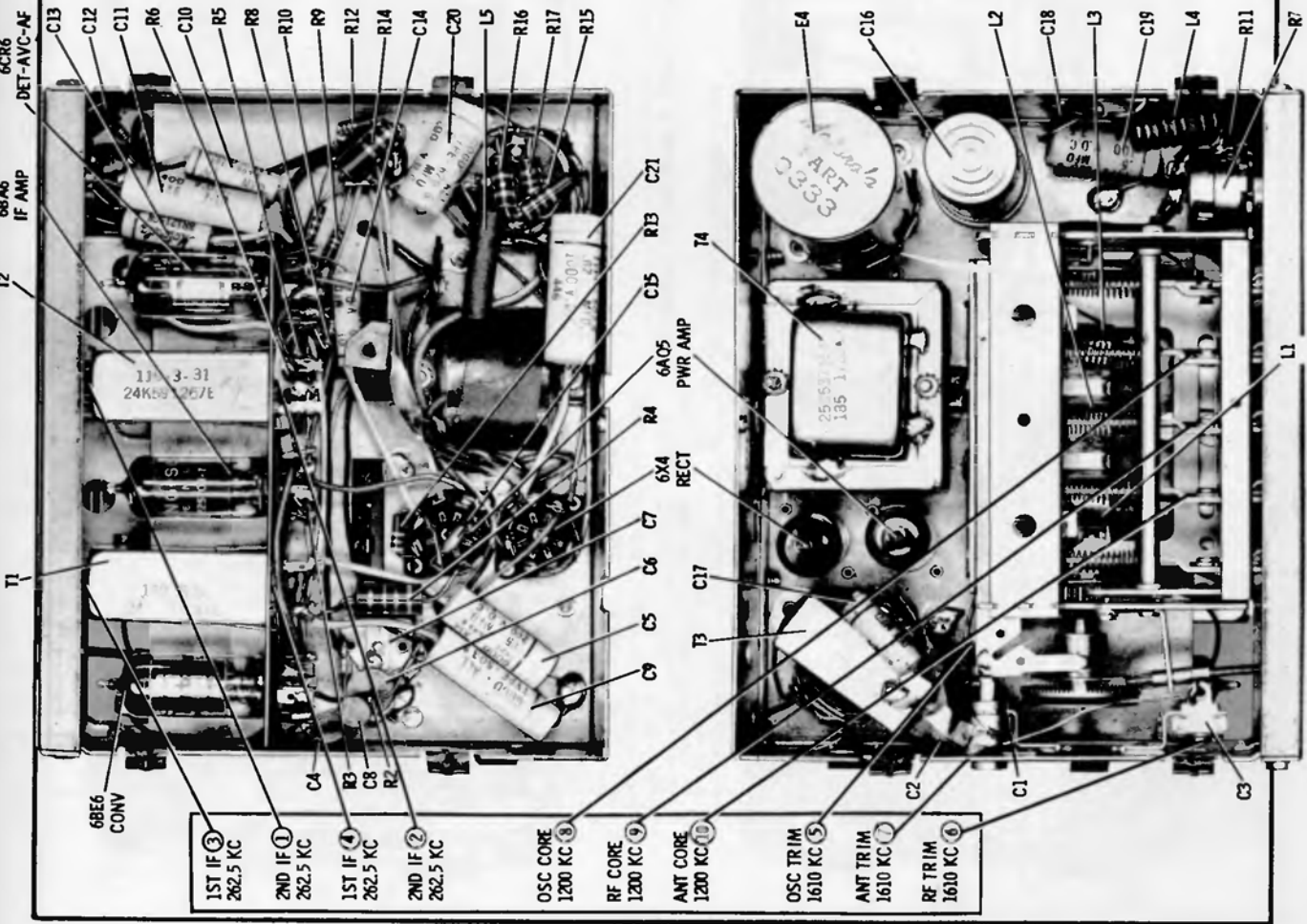
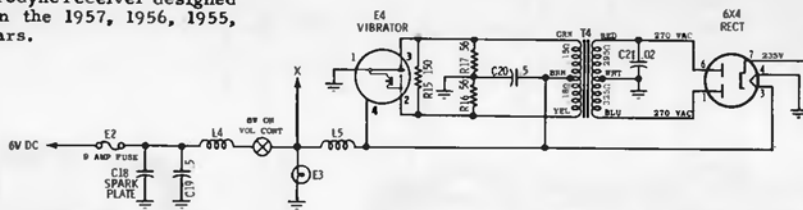

- 1ST IF ③ 262.5 KC
- 2ND IF ① 262.5 KC
- 1ST IF ④ 262.5 KC
- 2ND IF ② 262.5 KC
- OSC CORE ⑧ 1200 KC
- RF CORE ⑨ 1200 KC
- ANT CORE ⑩ 1200 KC
- OSC TRIM ⑤ 1610 KC
- ANT TRIM ⑦ 1610 KC
- RF TRIM ⑥ 1610 KC

ALIGNMENT ADJUSTMENTS AND PARTS LOCATIONS

**MOTOROLA**

Auto Radio Model 8M

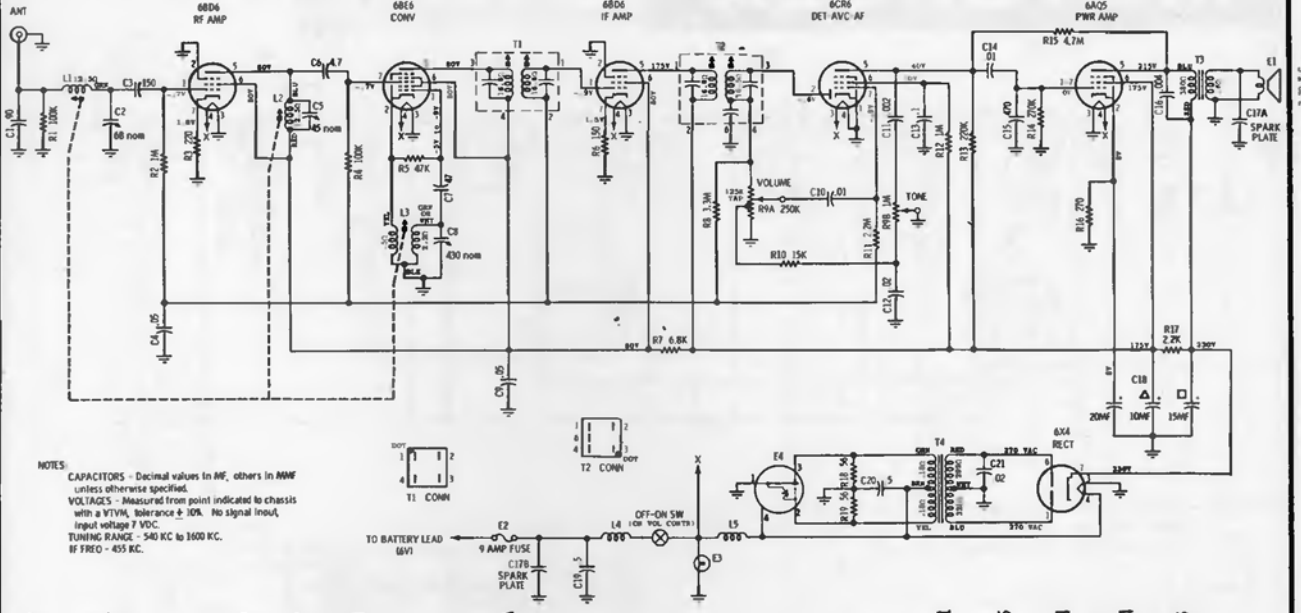

NOTES  
 CAPACITORS - Decimal values in MF, others in MMF unless otherwise specified.  
 VOLTAGES - Measured from point indicated to chassis with a VTVM, tolerance  $\pm 10\%$ . No signal input, input voltage 7 VDC.  
 TUNING RANGE - 540 KC to 1600 KC.  
 IF FREQ - 455 KC.

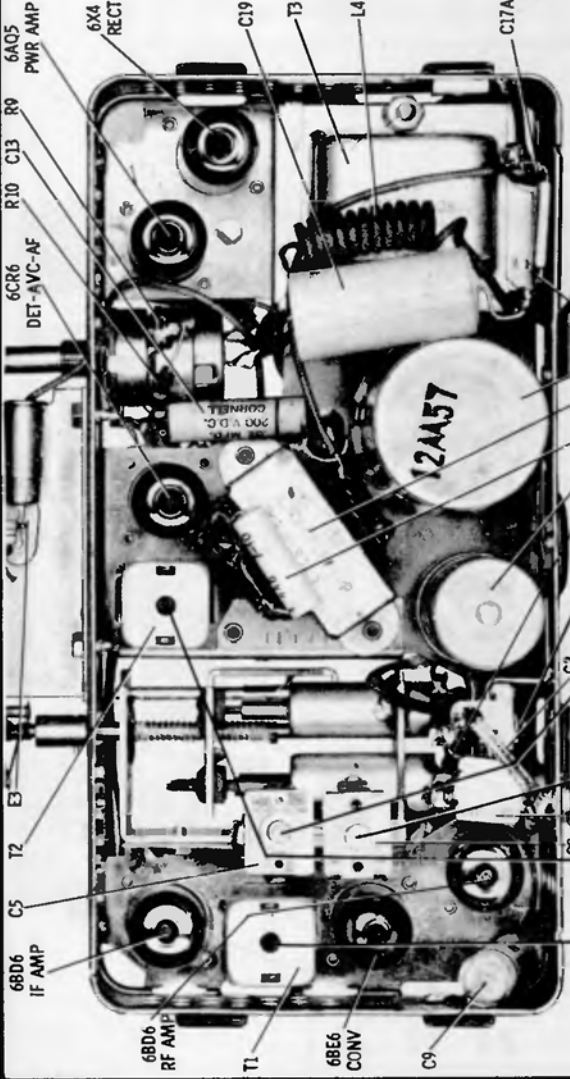

ALIGNMENT ADJUSTMENT & PARTS LOCATIONS

1	1ST IF	455 KC
2	2ND IF	455 KC
3	OSC TRIM	1610 KC
4	RF CORE	1400 KC
5	OSC TRIM	1610 KC
6	RF TRIM	1610 KC
7	ANT TRIM	1610 KC
8	ANT CORE	1400 KC

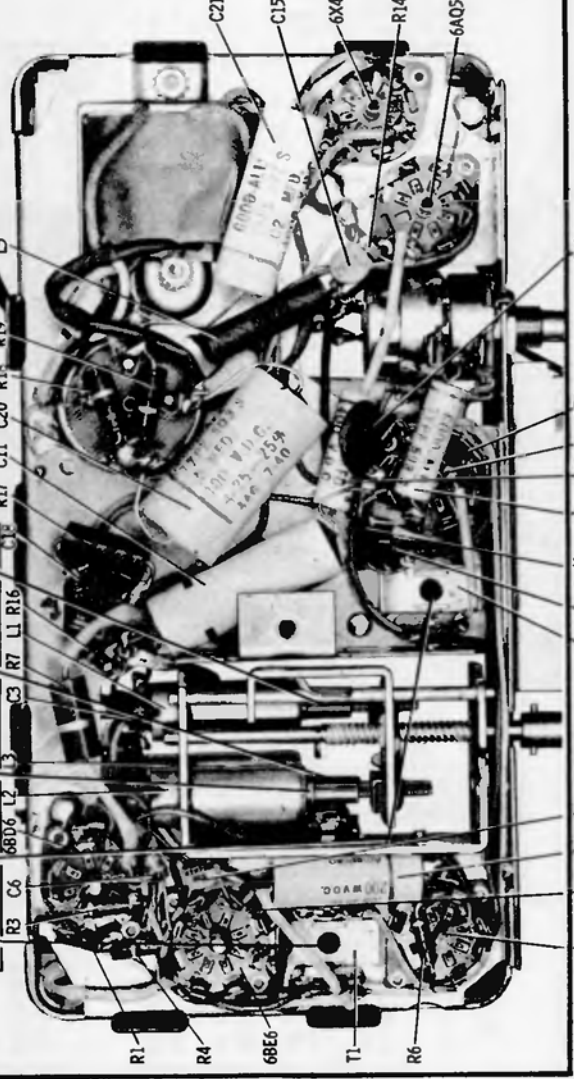

# MOTOROLA

AUTO RADIO

MODEL  
8MX

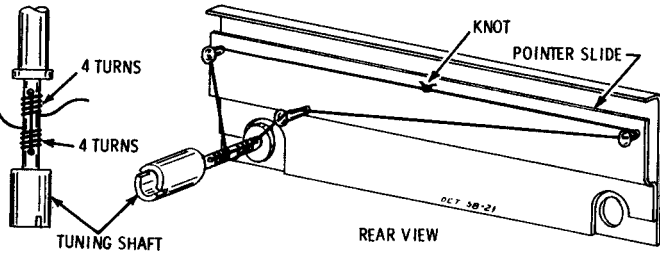

1. Thread a sufficient length of dial cord through two holes in shaft.
2. Wind 4 turns from each hole toward center of shaft as shown in detail.
3. Thread over guides and tie knot as shown.

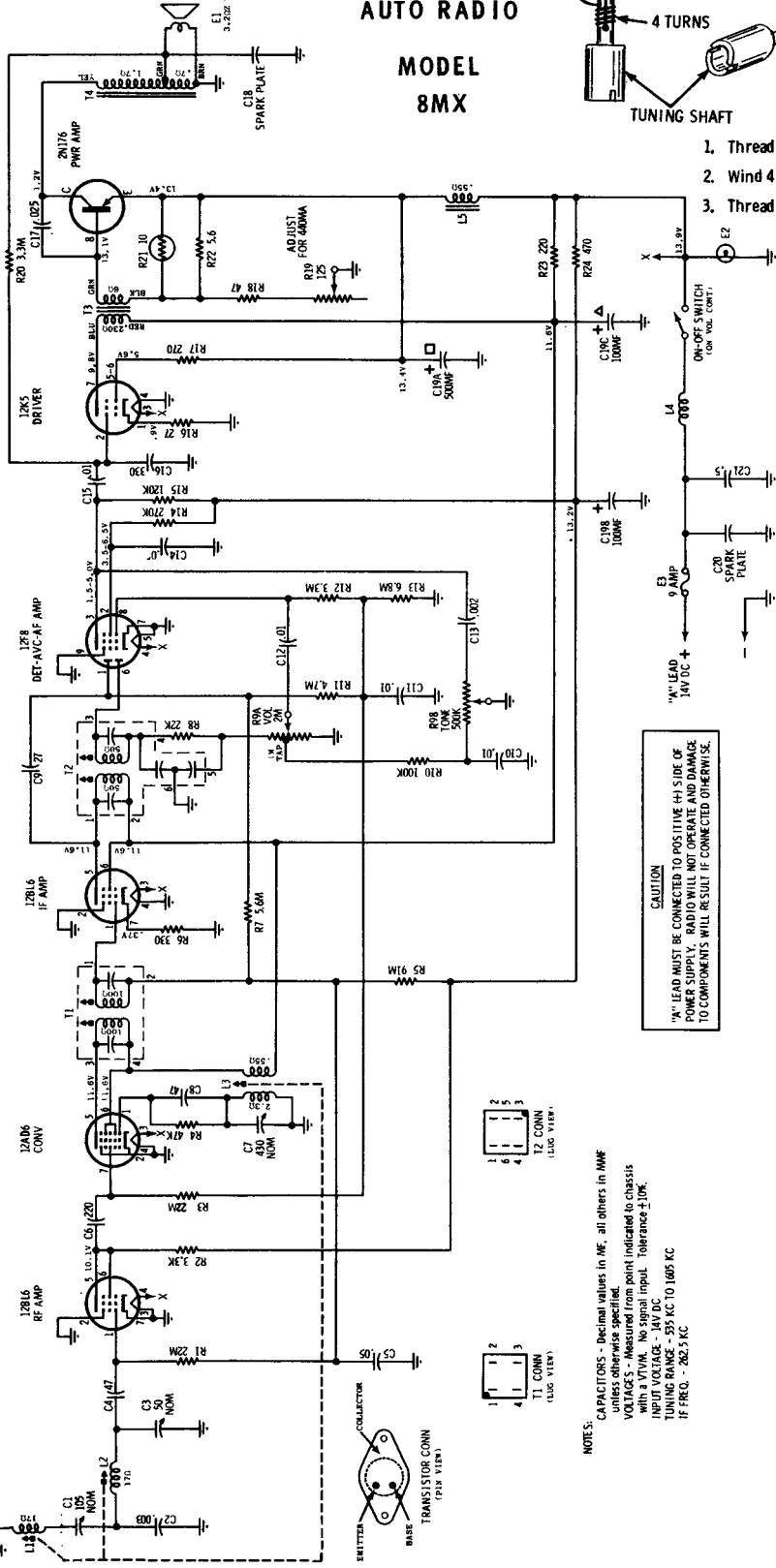

c. Adjust R-19 for a collector current reading of 360 ma with 12.6 volts input to radio "A" lead.

NOTE: Two values of radio input voltage are given as a convenience to service personnel to accommodate different power sources. The schematic collector current value of 440 ma is stated with 14 volts DC input to receiver "A" lead.

TRANSISTOR INSULATOR - When replacing a transistor or transistor insulator, be sure to coat both sides of insulator with DC-4 grease (Motorola Part No. 11M490487) to insure proper heat dissipation.

TRANSISTOR CHECK - Substituting a known good transistor for a suspected one is the simplest and most positive method of checking transistors. NOTE: When checking, be sure transistor insulator is in place (see SERVICE NOTE 6).

TUBE CHECK - Substituting a known good tube for a suspected one is the best and only check recommended at this time.

CAUTION  
"A" LEAD MUST BE CONNECTED TO POSITIVE (+) SIDE OF POWER SUPPLY. RADIO WILL NOT OPERATE AND DAMAGE TO COMPONENTS WILL RESULT IF CONNECTED OTHERWISE.

## SERVICE NOTES

TRANSISTOR REPLACEMENT - When replacing a transistor, be sure that the transistor insulator is in place and that the mounting screws are securely tightened. If insulator is not in place the transistor will be shorted to chassis and set will not operate. If mounting screws are not tight, the transistor will be damaged due to lack of proper heat dissipation.

TRANSISTOR CURRENT ADJUSTMENT - After the transistor has been replaced, the collector current should be checked and adjusted for proper operation.

- Set R-19 on back of receiver to its maximum resistance position (fully clockwise) to avoid excessive collector current, then allow radio to warm-up for 15 minutes.
- Open the output transformer T4 (speaker connected) by disconnecting the collector lead (Yel.) from the center lug of transistor socket, and insert a 0-1 amp DC Ammeter whose internal resistance is .05 ohms or less: (+) side of meter to lug of transistor socket and (-) side to yellow lead of transformer.

NOTES:  
CAPACITORS - Decimal values in MF, all others in MME unless otherwise specified.  
VOLTAGES - Measured from point indicated to chassis with a VTVM. No signal input. Tolerance  $\pm 1\%$ .  
INPUT VOLTAGE - 14V DC.  
TUNING RANGE - 535 KC TO 1605 KC  
IF FREQ. - 88.5 KC



# MOTOROLA

Auto Radio Model CTA8X  
(Service material continued on page 87, adjacent at right)

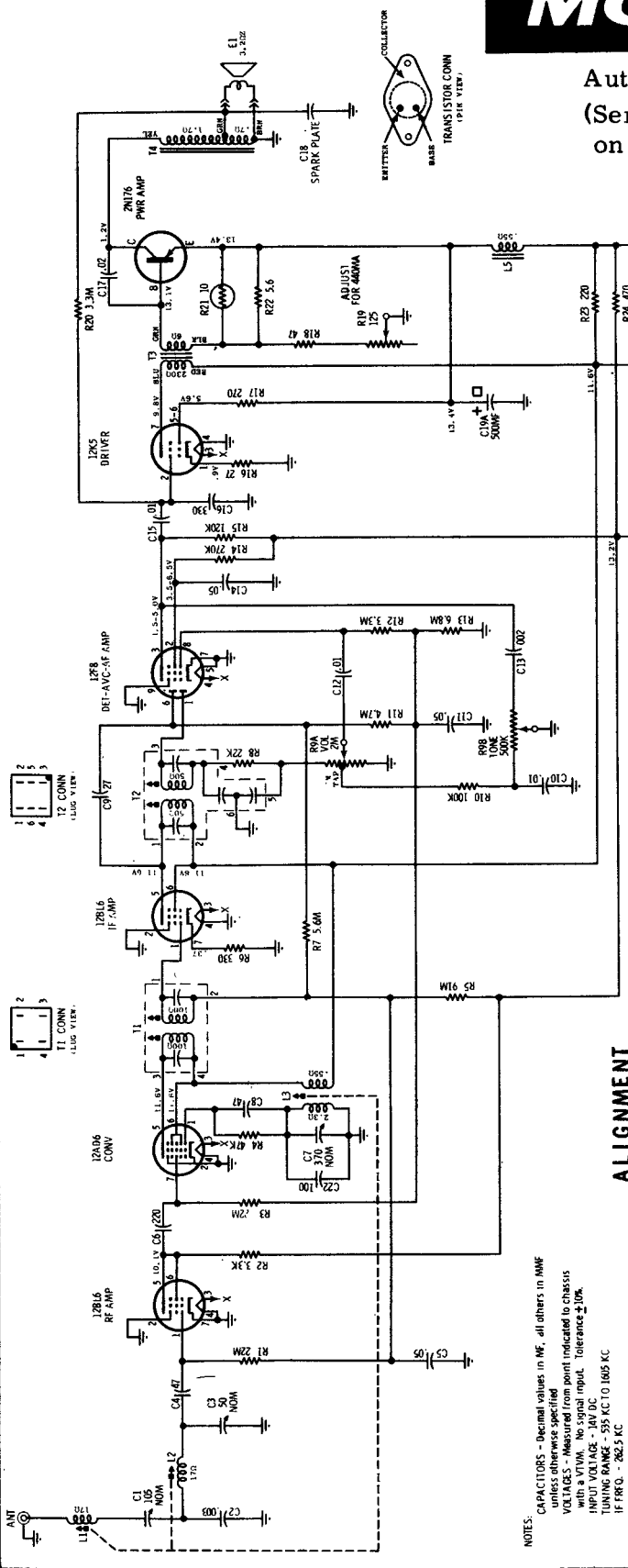

**ALIGNMENT**

STEP	GENERATOR CONNECTION	GENERATOR FREQUENCY (400 cycle mod)	TUNER SET TO	ADJUST	REMARKS
1.	IF ALIGNMENT Converter grid (pin 7) through .1 mf & chassis.	262.5 Kc	Hi end stop	1, 2, 3 & 4	Adjust for maximum.
2.	RF ALIGNMENT Ant receipt through dummy (see Fig.)	1610 Kc	Hi end stop	5, 6 & 7	Adjust for maximum.
3.	Ant receipt through dummy (see Fig.)	1610 Kc	Hi end stop	5, *6 & 7	Adjust for maximum.
4.	"	1200 Kc	Tuner carriage 9/32" from hi end stop	8, 9 & 10	Adjust for maximum, using alignment tool, Motorola Part No. 66A76278.
5.	"	1610 Kc	Hi end stop	5, 6 & 7	"
6.	Repeat steps 4 and 5 until no further increase.				Step 5 should be last adjustment.
7.	ANTENNA TRIMMER	-	Weak station Around 1400 Kc	7	With radio installed in car and antenna fully extended, adjust antenna trimmer for maximum.

NOTES:  
CAPACITORS - Decimal values in MF, all others in MMF unless otherwise specified  
VOLTAGES - Measured from point indicated to chassis with a VTVM. No signal input. Tolerance ±10%.  
12B6 VOLTAGE - 8V DC  
12B6 VOLTAGE - 5.5V AC 10 1605 KC  
IF FREQ. - 262.5 KC

NOTE: Do not perform steps 3, 4, 5 & 6 unless the tuner has been tampered with or components have been replaced. Remove the escutcheon and dial background plate to expose the core screws. Before proceeding with step 3, back the tuning core screws 7/16" out of the coils to eliminate their effect on trimmer adjustments.

CAUTION  
"A" LEAD MUST BE CONNECTED TO POSITIVE (+) SIDE OF POWER SUPPLY. RADIO WILL NOT OPERATE AND DAMAGE TO COMPONENTS WILL RESULT IF CONNECTED OTHERWISE.

**MOTOROLA**

Auto Radio Model CTA8X

(Continued from page 86)

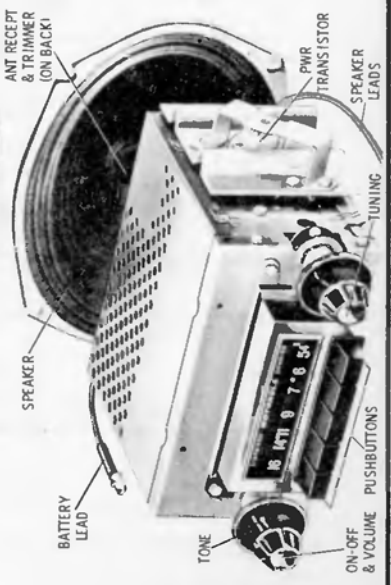
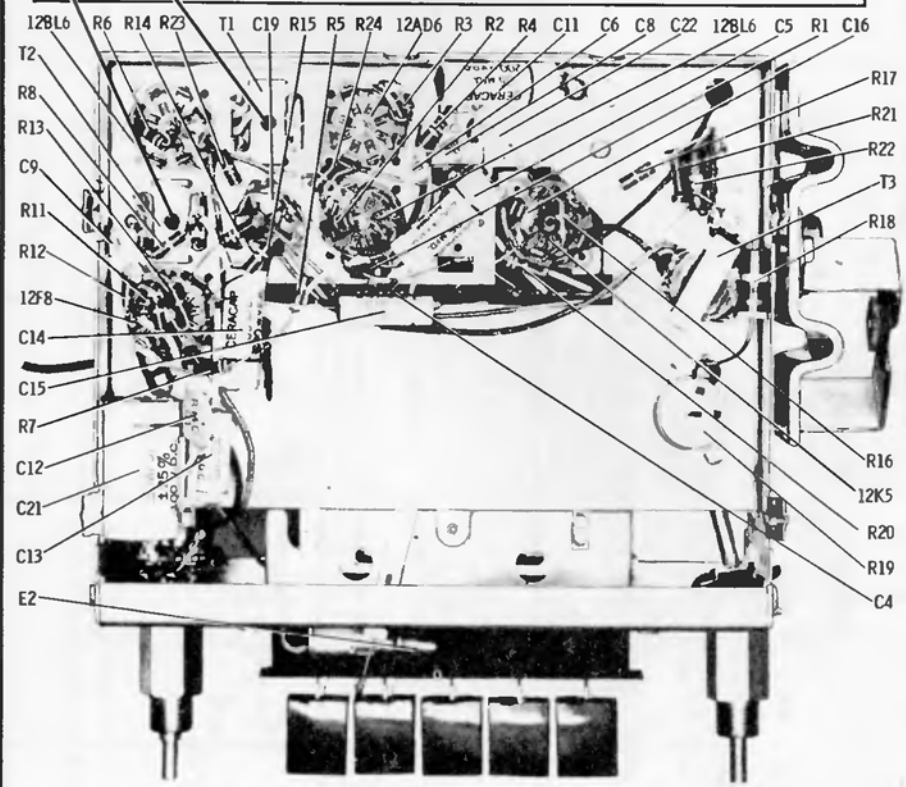
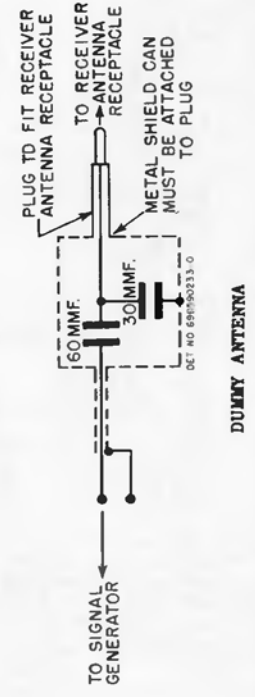
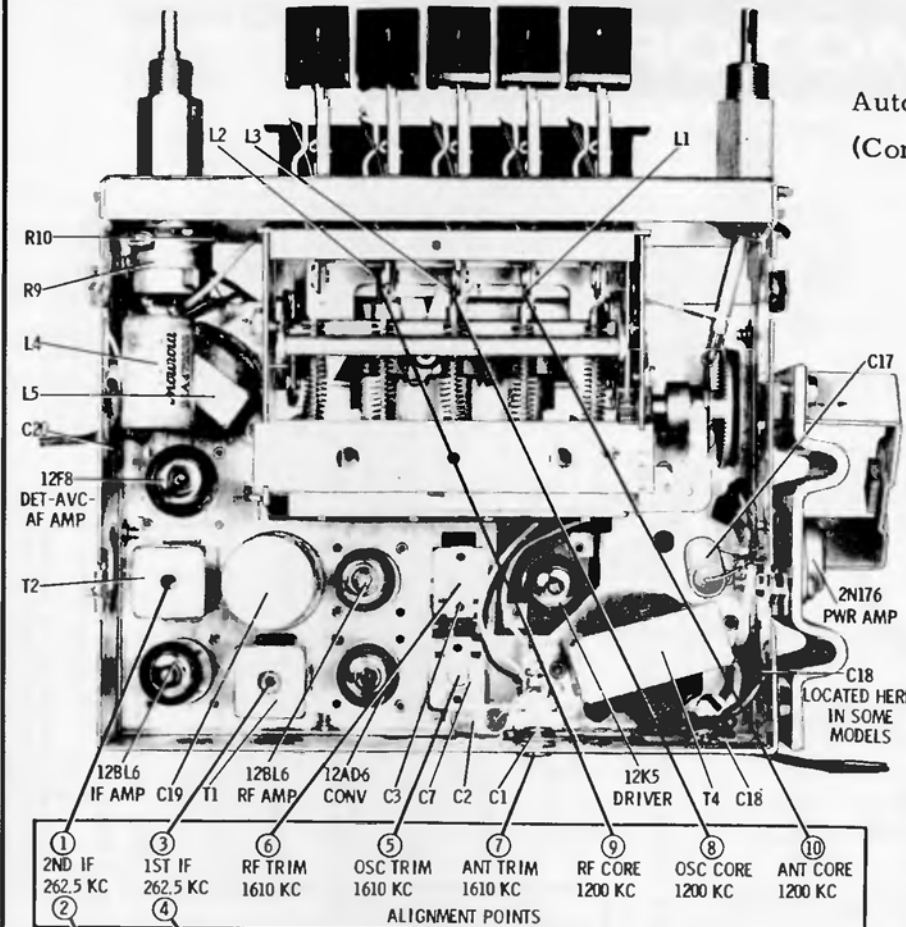

ALIGNMENT ADJUSTMENTS & PARTS LOCATIONS

# MOTOROLA

MODELS  
CTM8X  
CTM57X

Service material continued on page 89.

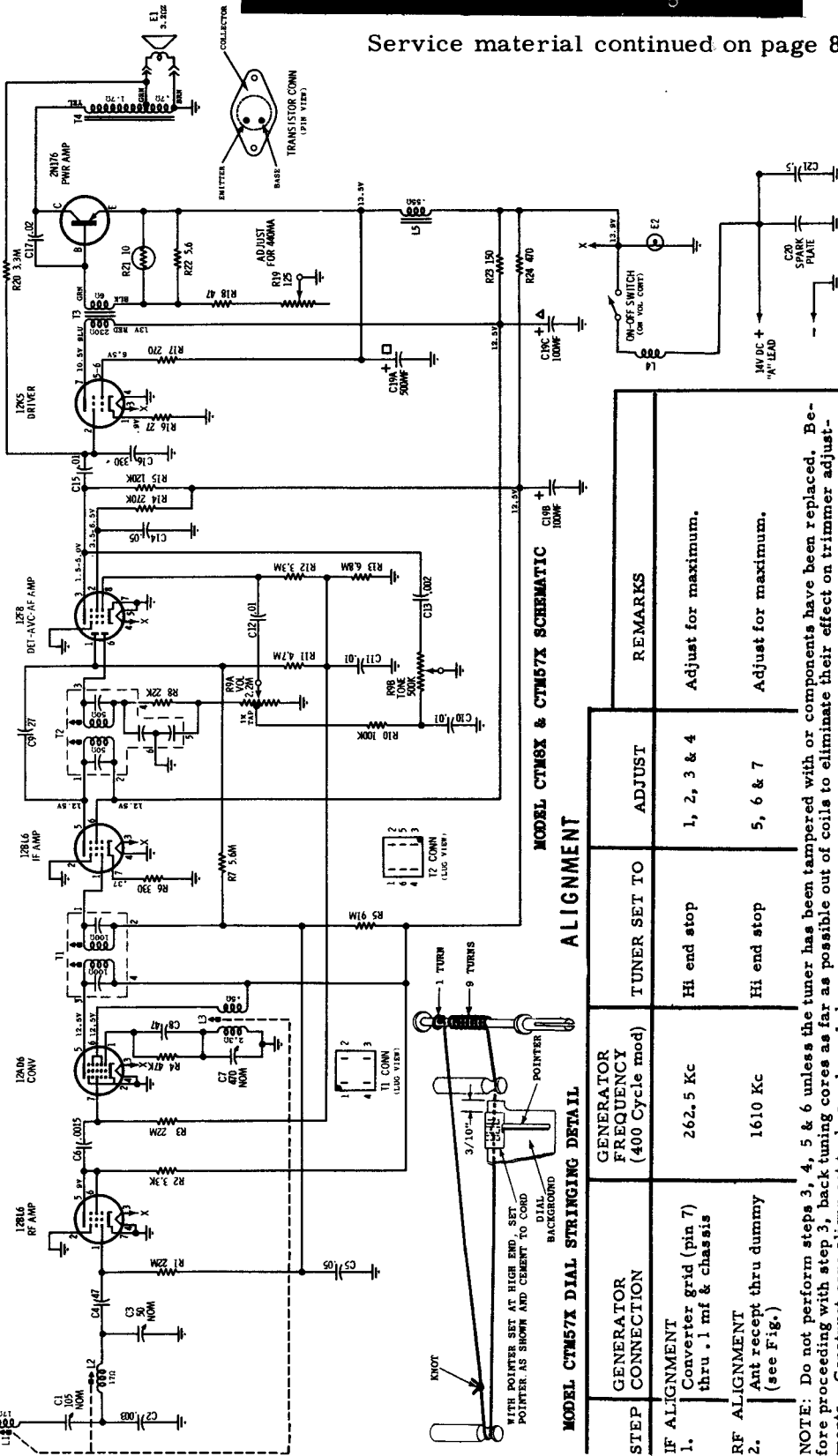

**CAUTION**  
"N" LEAD MUST BE CONNECTED TO POSITIVE (+) SIDE OF POWER SUPPLY. RADIO WILL NOT OPERATE AND DAMAGE TO COMPONENTS WILL RESULT IF CONNECTED OTHERWISE.

**NOTES:**  
CAPACITORS - Decimal values in MF, all others in MMF unless otherwise specified.  
VOLTAGES - Measured from point indicated to chassis with a VTVM. No signal input. Tolerance  $\pm 10\%$ .  
INPUT VOLTAGE - 140 DC  
INPUT VOLTAGE - 140 DC  
INPUT VOLTAGE - 140 DC  
IF FREQ. - 262.5 Kc

### MODEL CTM57X DIAL STRINGING DETAIL

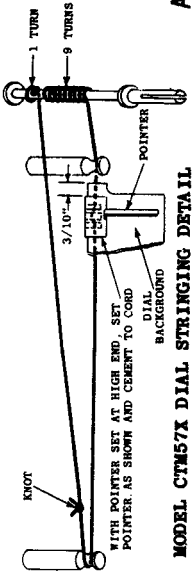

### ALIGNMENT

STEP	GENERATOR CONNECTION	GENERATOR FREQUENCY (400 Cycle mod)	TUNER SET TO	ADJUST	REMARKS
1.	IF ALIGNMENT Converter grid (pin 7) thru .1 mf & chassis	262.5 Kc	Hi end stop	1, 2, 3 & 4	Adjust for maximum.
2.	RF ALIGNMENT Ant recept thru dummy (see Fig.)	1610 Kc	Hi end stop	5, 6 & 7	Adjust for maximum.
3.	Ant recept thru dummy (see Fig.)	1610 Kc	Hi end stop	5, 6 & 7	Adjust for maximum.
4.	"	1400 Kc	Tuner carriage 13/64" from hi end stop	8, 9 & 10	Adjust for maximum.
5.	"	1610 Kc	Hi end stop	5, 6 & 7	Adjust for maximum.
6.	Repeat steps 4 & 5 until no further increase, then cement tuning cores in place; step 5 should be last adjustment.				
7.	ANTENNA TRIMMER		Weak station around 1400 Kc	7	With radio installed in car and antenna fully extended, adjust antenna trimmer for maximum.

(For location of alignment adjustments, see illustrations on page 89)



**MOTOROLA**

Models CTM8X and CTM57X (Continued)

(See page 88 for circuit diagram and additional service material)

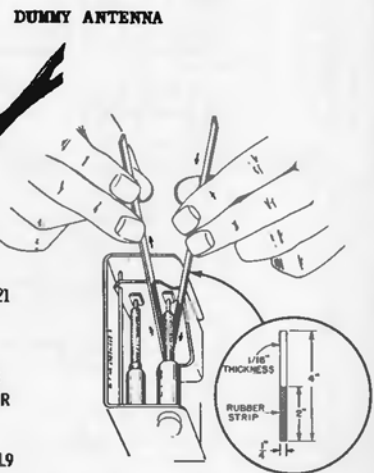
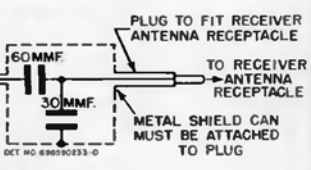
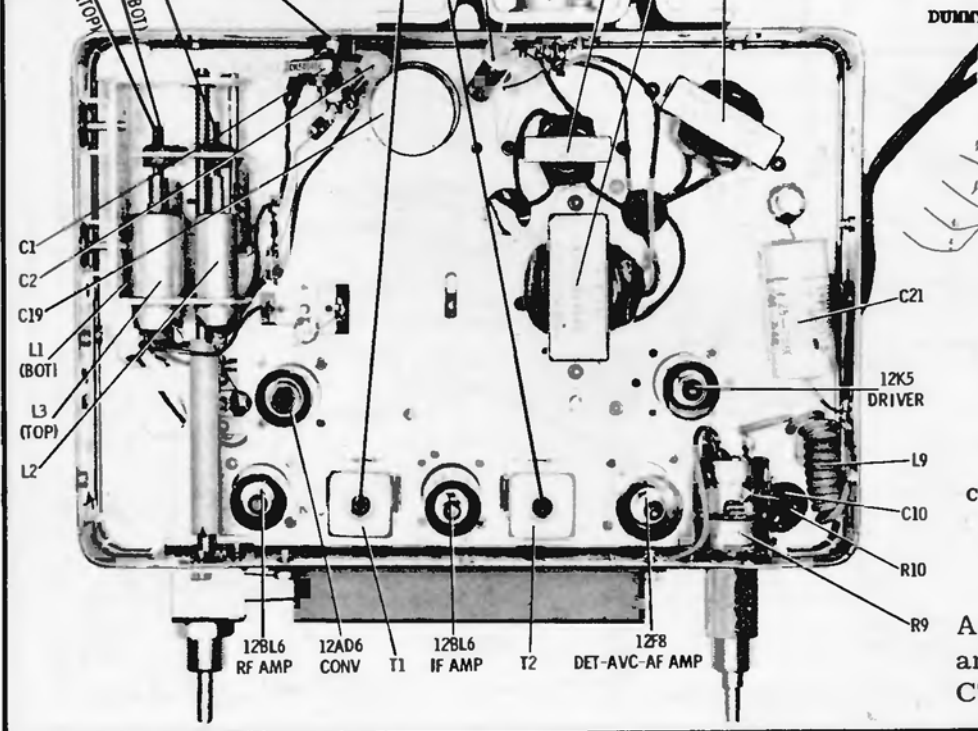
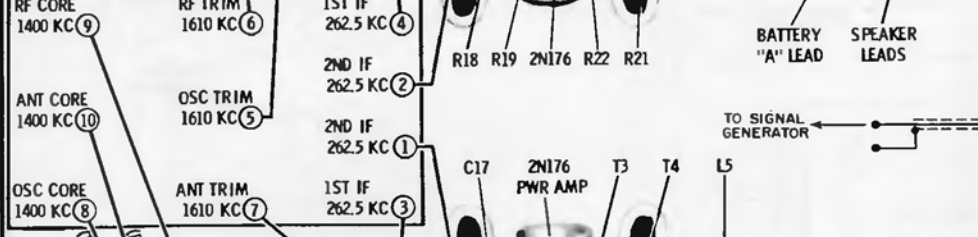
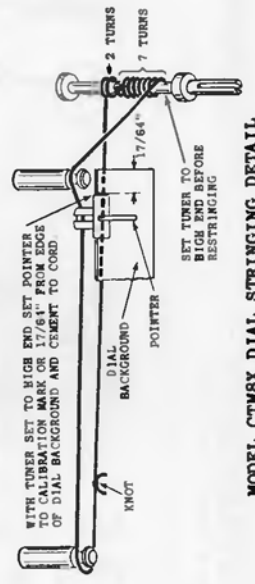
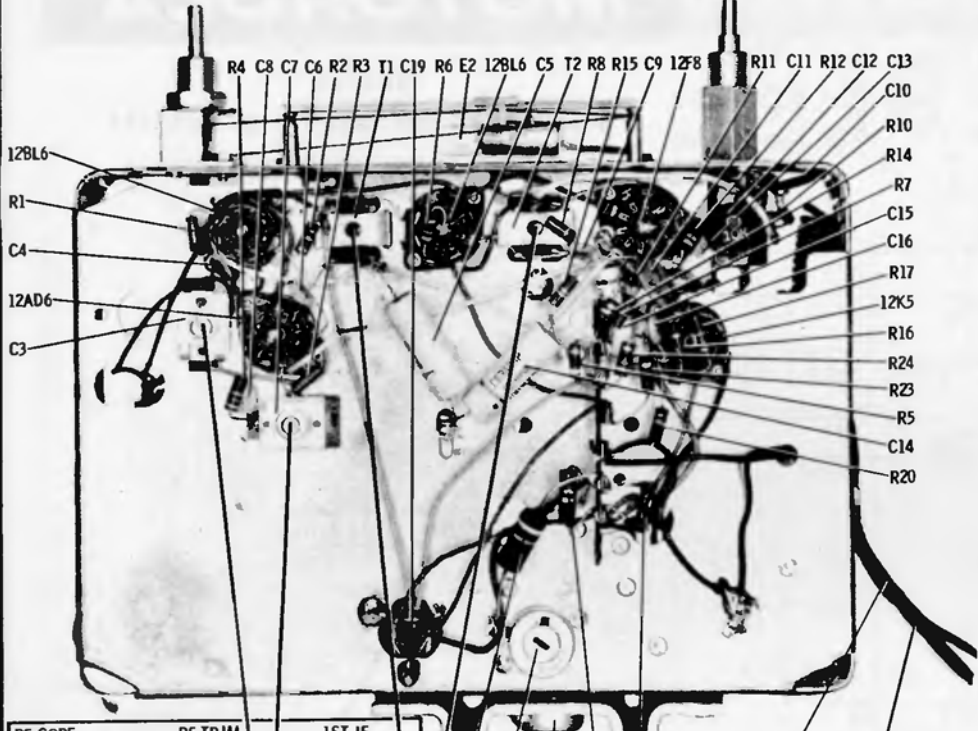

Model CTM8X Alignment adjustments and parts locations. CTM57X is similar.

# MOTOROLA

## MODELS

MOTOROLA 74MF FORD B7A-18805-A1

MOTOROLA 84MF FORD B8A-18805-B

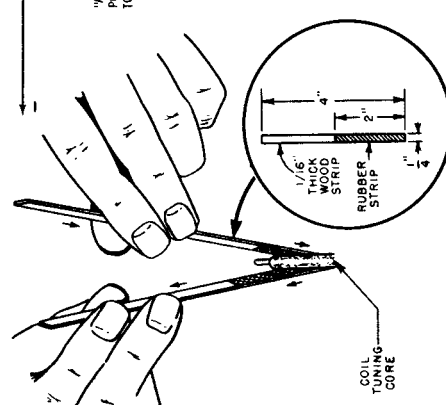
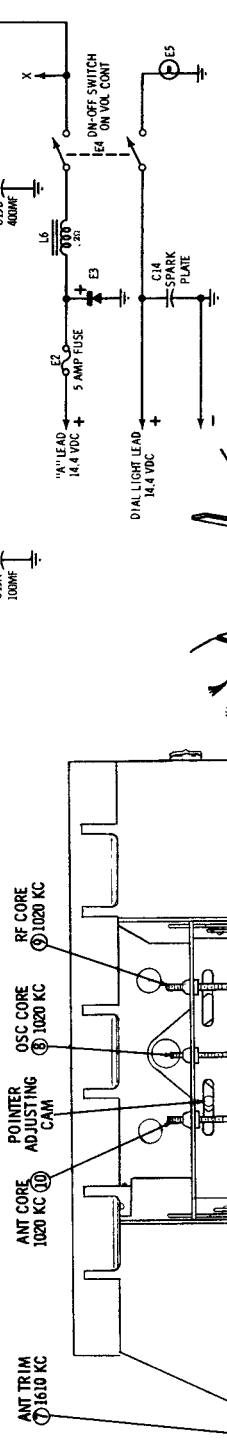
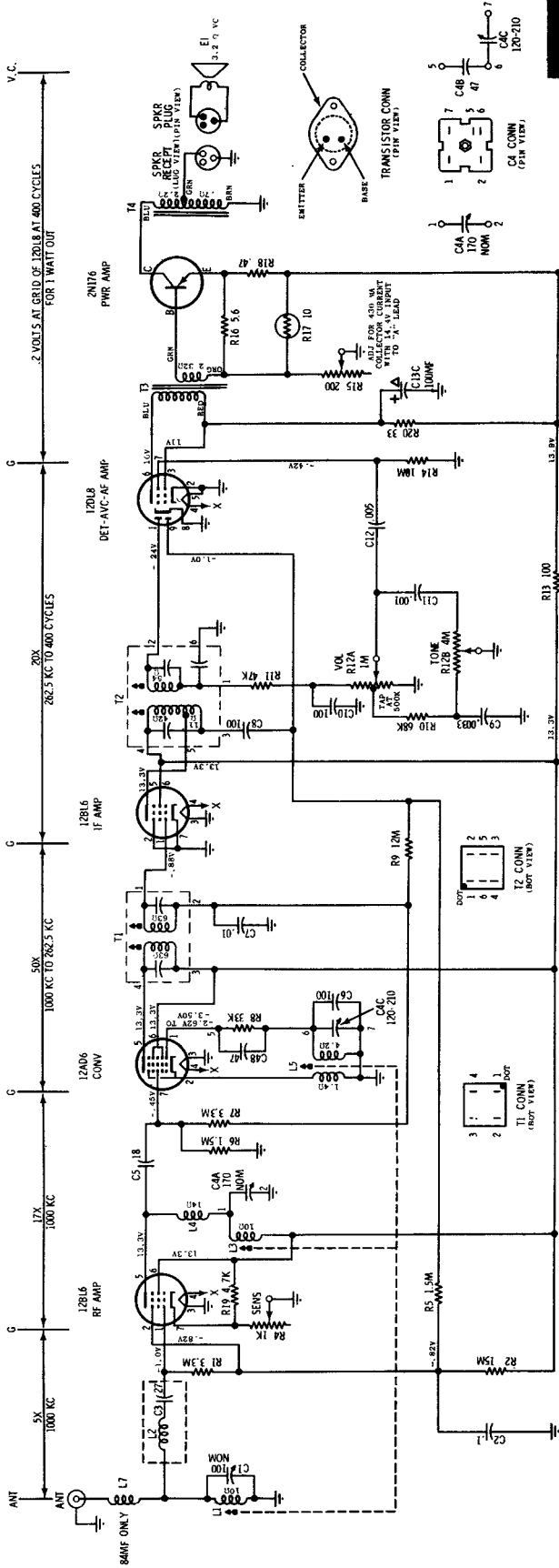

CORE ALIGNMENT TOOL DETAIL

**CAUTION**  
 \*AN LEAD MUST BE CONNECTED TO POSITIVE (B) SIDE OF POWER SUPPLY. \*IF NOT CONNECTED TO POSITIVE, COMPONENTS WILL RESULT IF CONNECTED OTHERWISE.

**NOTES:**  
 CAPACITORS - Decimal values in MF. All others in MMF unless otherwise specified.  
 VOLTAGES - Measured from point indicated to chassis with a VTVM. Tolerance  $\pm 10\%$ .  
 No signal input.  
 IF - 262.5 KC.  
 TUNING RANGE - 540 KC TO 1610 KC.  
 Resistance measured in power amp stage with transistor removed.

# MOTOROLA

## MODELS

MOTOROLA 76MF(SR) FORD B7A-18805-B1  
 MOTOROLA 86MF FORD B8A-18805-A

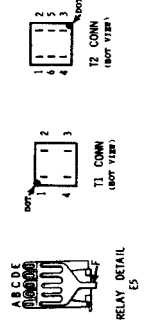
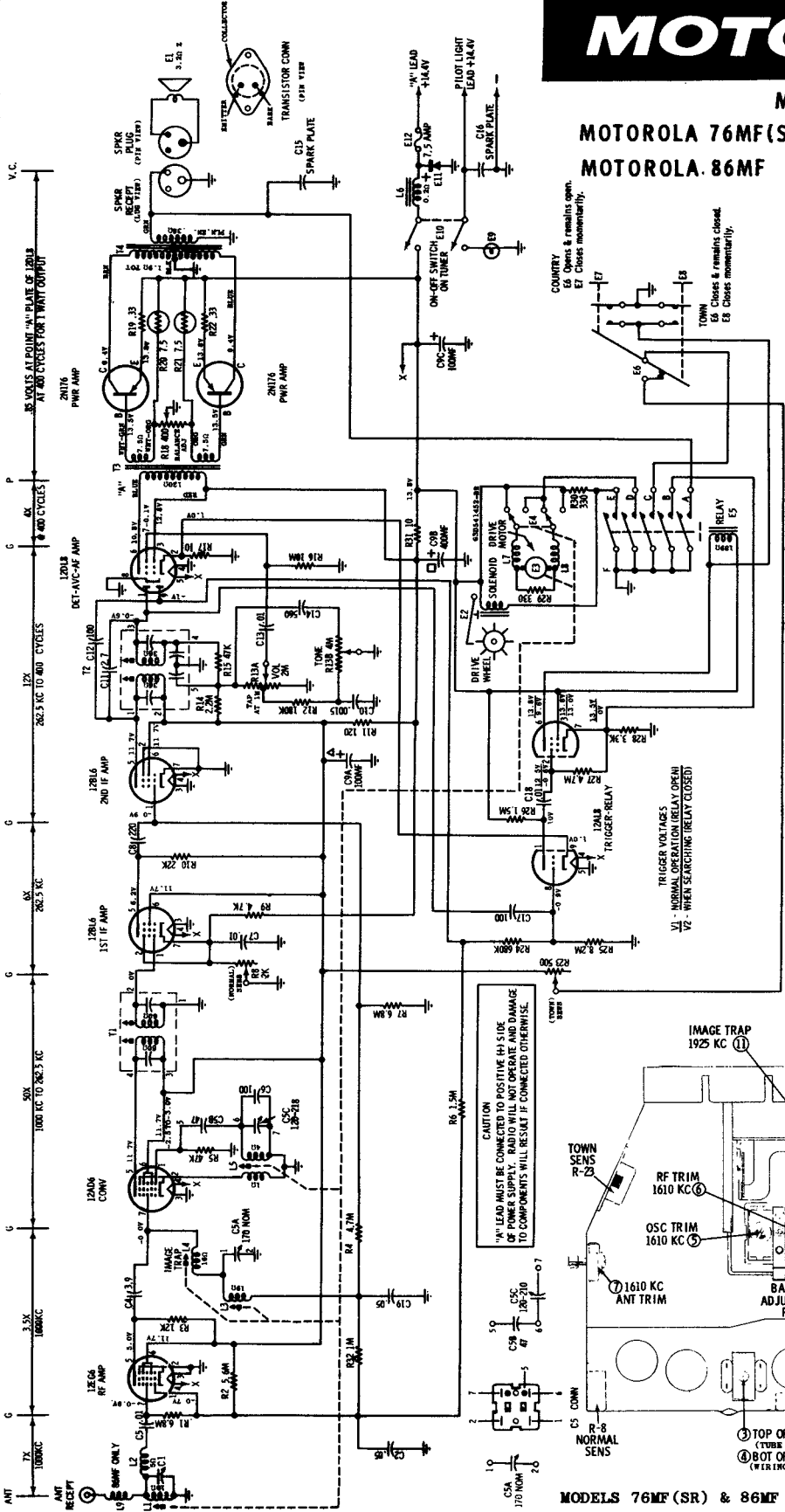

NOTES:  
 CAPACITORS - decimal values in MF. All others in MMF unless otherwise specified.  
 Values in VTVM - 100K. Non-pertinent indicated to chassis.  
 INPUT VOLTAGE - 1A/100C.  
 TUNING RANGE - 540-1610KC.  
 IF - 262.5KC.  
 Resistance in power amp stage made with transistors removed.

**TRANSISTOR CURRENT ADJUSTMENT** - After replacing transistor and before connecting radio to power supply, set the transistor balance control (R-18) to the mid-position to prevent excessive current from damaging the transistors. Allow about 15 minutes warm-up time before proceeding with the following:

- Connect a VTVM from collector to collector. Be sure VTVM is accurately zeroed and set to a low voltage scale. NOTE: If VTVM has a center zero scale, use this scale.
  - Adjust R-18 for zero DC reading on VTVM.
- TRANSISTOR INSULATOR** - When replacing a transistor or transistor insulator, be sure to coat both sides of insulator with DC-4 grease (Motorola Part No. 11M490487) to insure proper heat dissipation.

CAUTION  
 "N" LEAD MUST BE CONNECTED TO POSITIVE (+) SIDE OF POWER SUPPLY. RADIO WILL NOT OPERATE AND DAMAGE TO COMPONENTS WILL RESULT IF CONNECTED OTHERWISE.

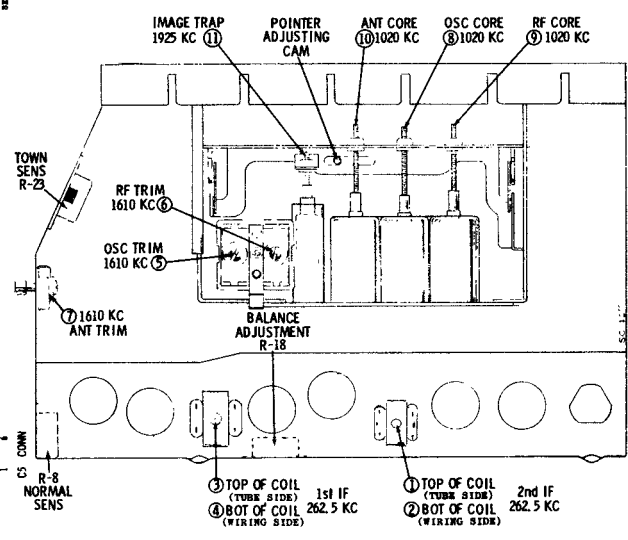

MODELS 76MF(SR) & 86MF ALIGNMENT POINT LOCATION DETAIL

# MOTOROLA

MODEL  
AMERICAN MOTORS 8990543  
MOTOROLA 83MR

(Continued on page 93)

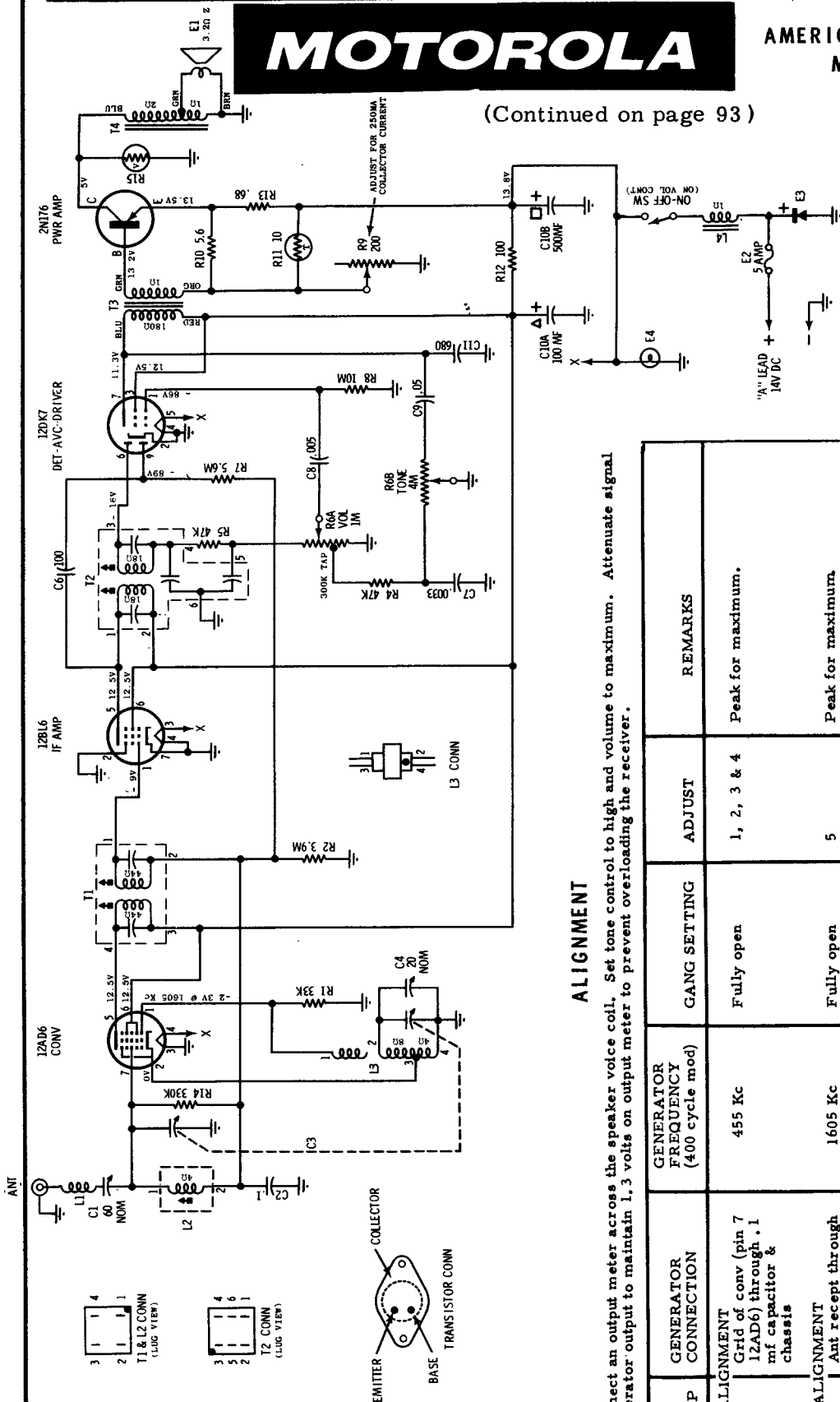

**CAUTION**  
"A" LEAD MUST BE CONNECTED TO POSITIVE (+) SIDE OF POWER SUPPLY. RADIO WILL NOT OPERATE AND DAMAGE TO COMPONENTS WILL RESULT IF CONNECTED OTHERWISE.

**NOTES:**  
CAPACITORS - Decimal values in MF. All others in MMF unless otherwise specified.  
VOLTAGES - Measured from point indicated to chassis.  
INPUT VOLTAGE - 14V DC  
TUNING RANGE - 540 KC to 1605 KC  
IF - 455 KC

## ALIGNMENT

Connect an output meter across the speaker voice coil. Set tone control to high and volume to maximum. Attenuate signal generator output to maintain 1.3 volts on output meter to prevent overloading the receiver.

STEP	GENERATOR CONNECTION	GENERATOR FREQUENCY (400 cycle mod)	GANG SETTING	ADJUST	REMARKS
1.	IF ALIGNMENT Grid of conv (pin 7 12AD6) through .1 mf capacitor & chassis	455 Kc	Fully open	1, 2, 3 & 4	Peak for maximum.
2.	RF ALIGNMENT Ant receipt through dummy antenna.	1605 Kc	Fully open	5	Peak for maximum.
3.	"	1400 Kc	Tune for max	6	Peak for maximum.
4.	"	600 Kc	Tune for max	7	Peak for maximum while rocking gang.
5.	Repeat steps 3 & 4 until no further increase.		The last adjustment should be the trimmer (6).		
6.	ANTENNA TRIMMER	-	Tune to a weak station around 1400 Kc	6	With radio installed in car and antenna fully extended, peak antenna trimmer for max.

(For location of alignment adjustments see illustration on page 93)

# MOTOROLA

Model 83MR, American Motors 8990543  
(Continued from page 92)

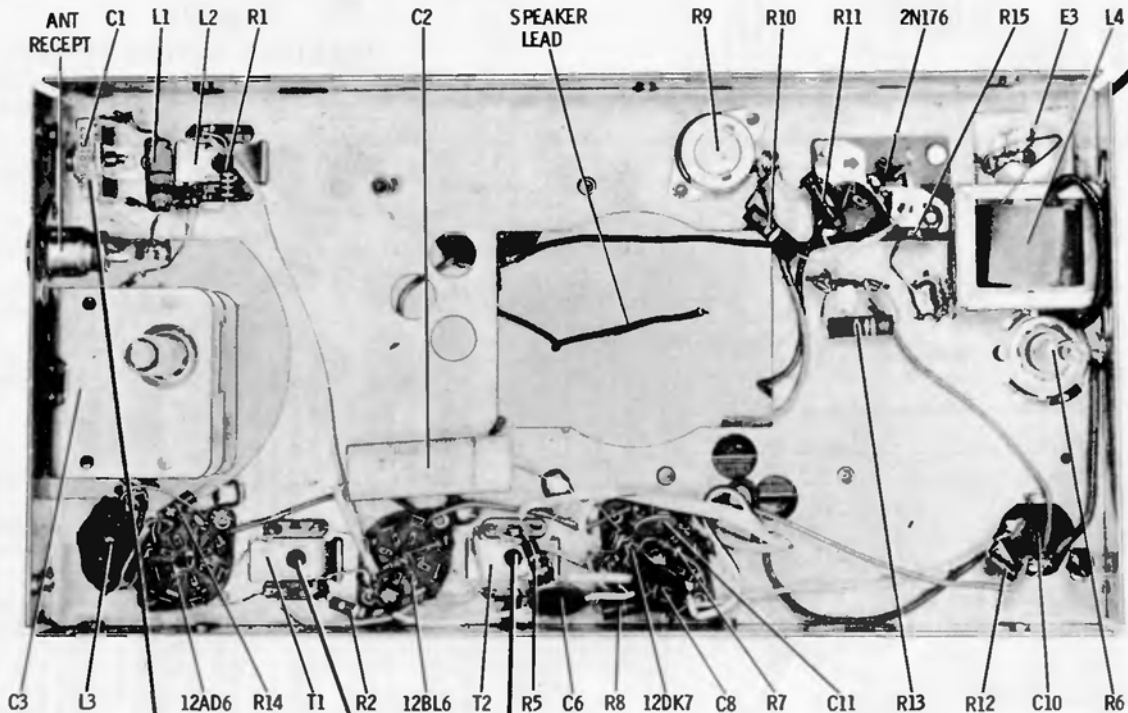

⑥	④	②
OSC TRIM 1605 KC	ANT TRIM 1400 KC	ANT CORE 600 KC
⑤	⑦	③
		1ST IF 455 KC
		①
		2ND IF 455 KC

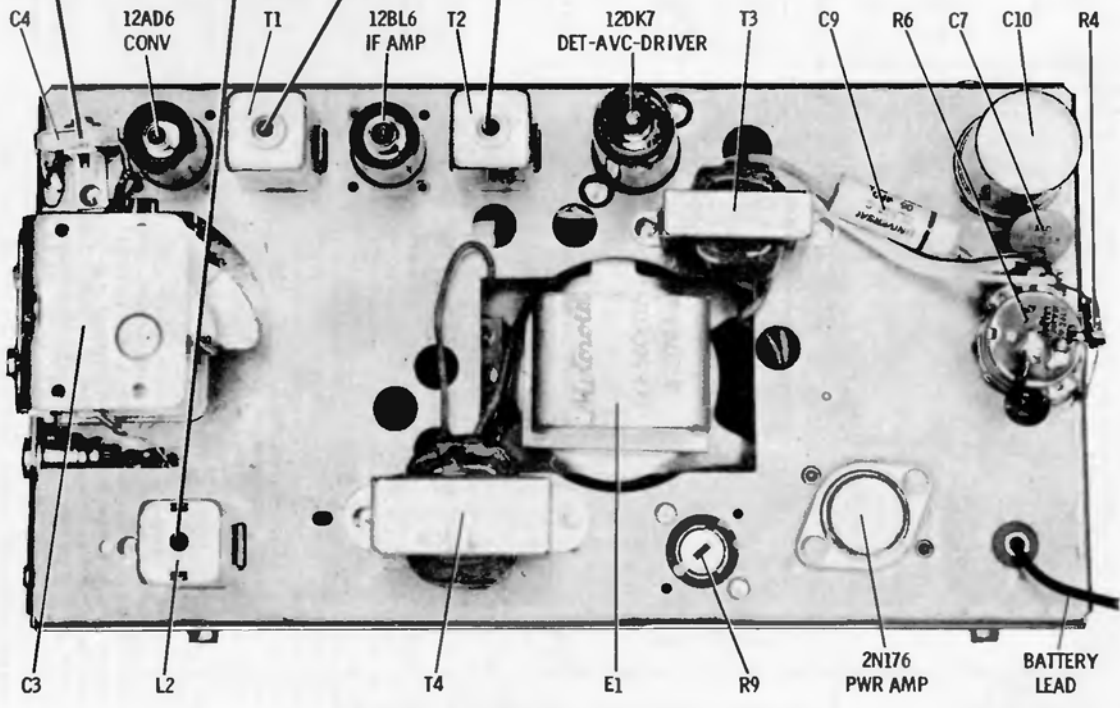
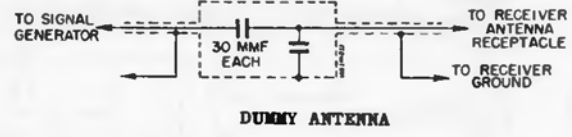

ALIGNMENT ADJUSTMENTS AND PARTS LOCATIONS



MODEL  
AMERICAN MOTORS 8990494  
MOTOROLA 84MA

(Continued on page 95)

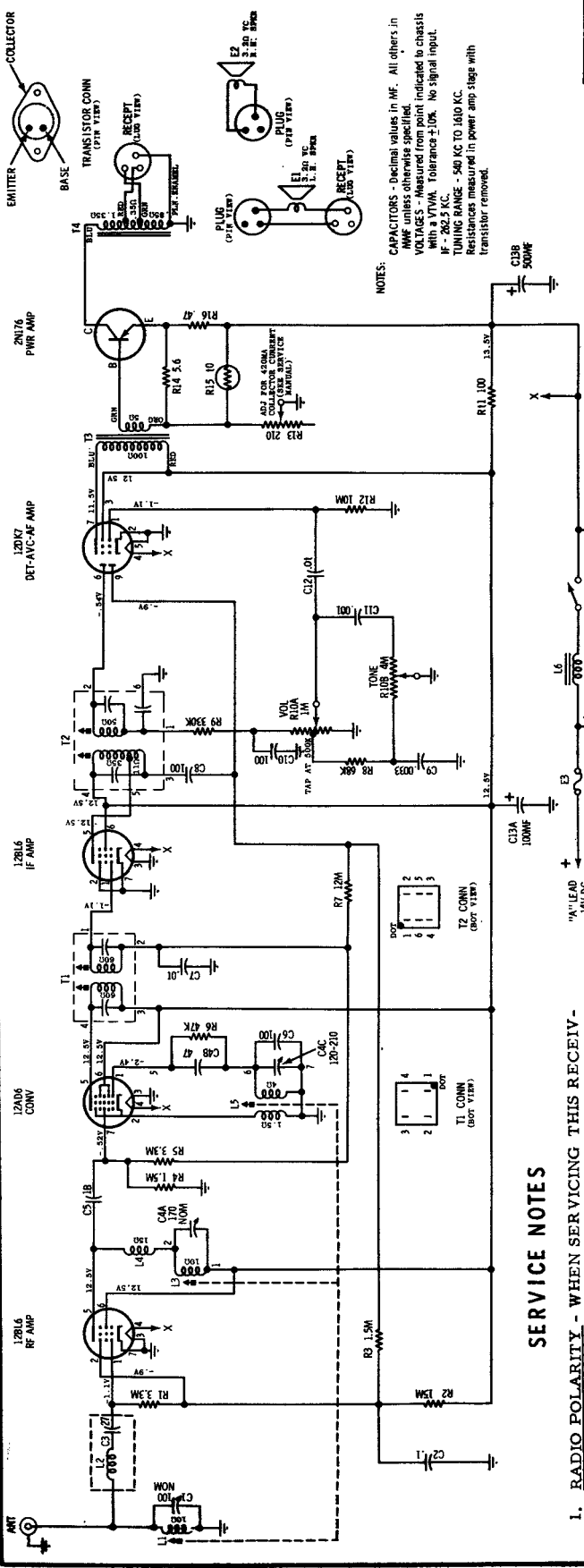

NOTES:  
CAPACITORS - Decimal values in MF. All others in microfarads. Values in parentheses indicated to chassis voltage. All values are tolerance  $\pm 10\%$ . No signal input.  
TUNING RANGE - 540 KC TO 1400 KC.  
Resistances measured in power amp stage with transistor removed.

CAUTION  
"A" LEAD MUST BE CONNECTED TO POSITIVE HI SIDE OF POWER SUPPLY. RADIO WILL NOT OPERATE AND DAMAGE TO COMPONENTS WILL RESULT IF CONNECTED OTHERWISE.

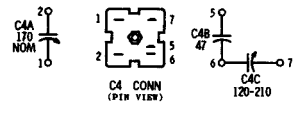

**SERVICE NOTES**

- RADIO POLARITY** - WHEN SERVICING THIS RECEIVER ON THE SERVICE BENCH, BE SURE THAT THE RECEIVER "A" LEAD IS CONNECTED TO THE POSITIVE SIDE OF THE POWER SOURCE AND THAT THE RECEIVER HOUSING IS CONNECTED TO THE NEGATIVE SIDE. IF CONNECTED OTHERWISE, THE RECEIVER WILL NOT OPERATE AND DAMAGE TO COMPONENTS MAY RESULT.
- POWER SUPPLY REQUIREMENTS** - It is preferable to use a storage battery (without a battery charger) in place of a battery eliminator when servicing this receiver, because the average eliminator has an extremely high AC ripple content which may damage the transistor and other low voltage components. The average output of the eliminator may be read as 14 volts, but the peak ripple may actually be 15 to 25 volts or higher. Only a well filtered and regulated eliminator type power supply should be used to service this receiver in place of the storage battery recommended.
- SERVICING PRECAUTION** - When servicing this receiver, probing with a screwdriver (checking for spark to ground from various points) must be avoided, because the plate power is obtained directly from the storage battery and high currents can flow through the components causing permanent damage. The transistor stage is especially susceptible to damage from this type of check. If the transistor BASE electrode is shorted to ground (either directly or through any other path) the BASE bias will be removed allowing excessive current to flow through the transistor causing permanent damage by melting the indium junctions in the transistor.
- TRANSISTOR REPLACEMENT** - When replacing a transistor, be sure that the transistor insulator is in place and that the mounting screws are securely tightened. If insulator is not in place the transistor will be shorted to chassis and set will not operate. If mounting screws are not tight, the transistor will be damaged due to a lack of proper heat dissipation. NOTE: When a transistor is replaced the current should be checked (see SERVICE NOTE 5 and 6).
- TRANSISTOR CURRENT ADJUSTMENT** - After replacing transistor and before connecting radio to power supply, set the transistor bias control (R-13) to the maximum (fully counterclockwise) position to prevent excessive current from damaging the transistor. Allow about 15 minutes warm-up time before proceeding with the following:
  - Connect a VTVM from transistor collector electrode (external shell) to chassis.
  - Adjust R-13 for .98 volts on VTVM. (This corresponds to a collector current of 420 MA).
  - Repeat Step b after a half hour.
- TRANSISTOR INSULATOR** - When replacing a transistor or transistor insulator, be sure to coat both sides of insulator with DC-4 grease (Motorola Part No. 11M490487) to insure proper heat dissipation.
- TRANSISTOR CHECK** - Substituting a known good transistor for a suspected one is the simplest and most positive method of checking transistors.

VOLUME R-18, MOST-OFTEN-NEEDED 1958 RADIO SERVICING INFORMATION

MOTOROLA Model 84MA, American Motors 8990494, Continued from page 94

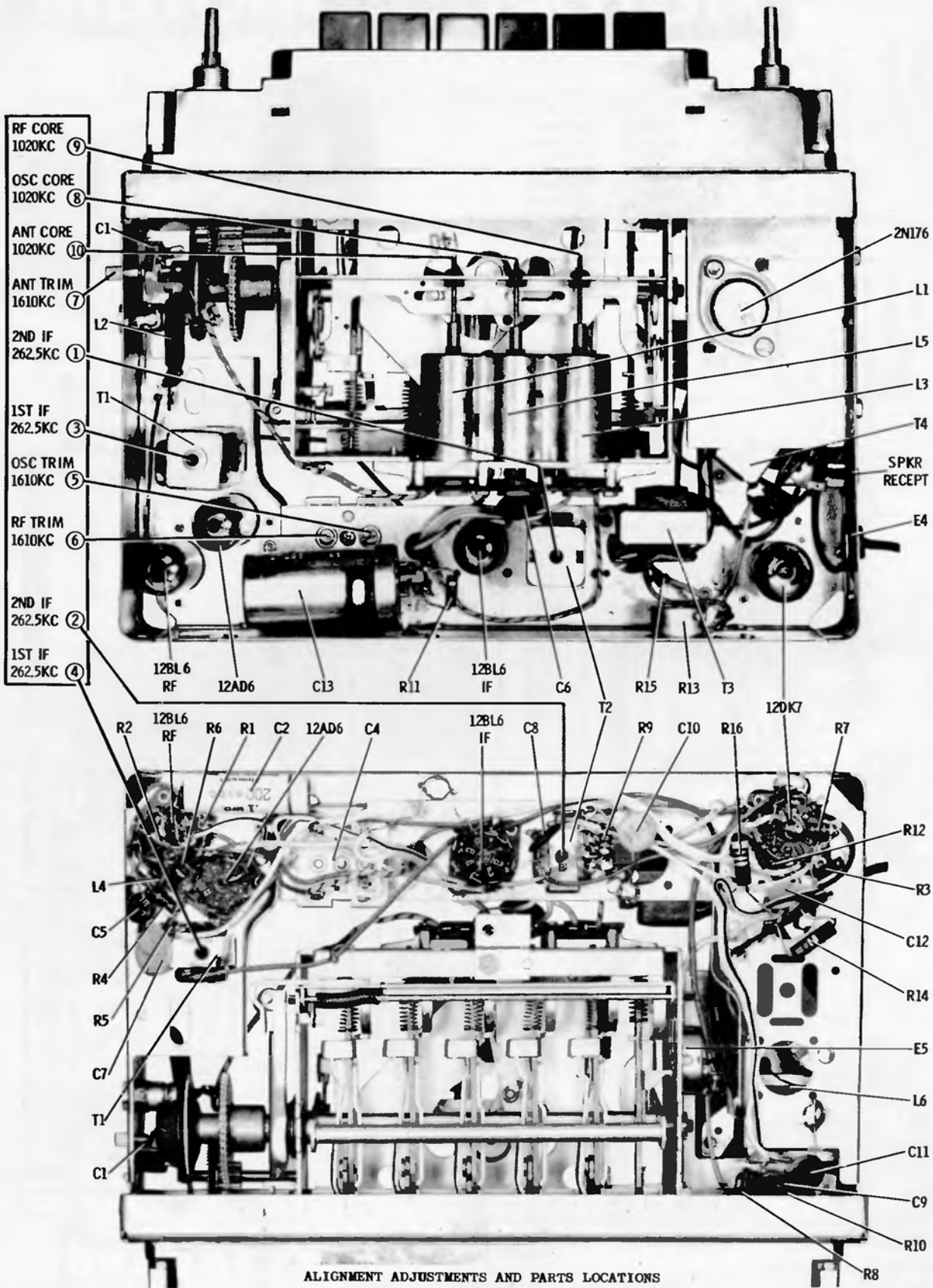

# MOTOROLA

MOTOROLA 84MS  
FORD FEV-18805-F

TUBE AND TRANSISTOR COMPLEMENT

- |       |                |
|-------|----------------|
| 12AF6 | RF amp         |
| 12AD6 | Converter      |
| 12BL6 | IF amp         |
| 12DL8 | Det-AVC-AF amp |
| 2N176 | Pwr amp        |
| 2N176 | Pwr amp        |

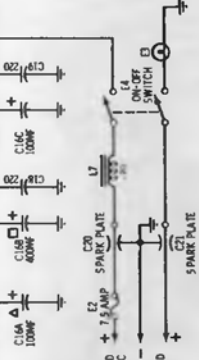
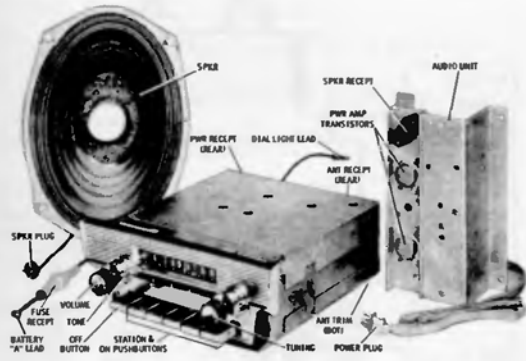
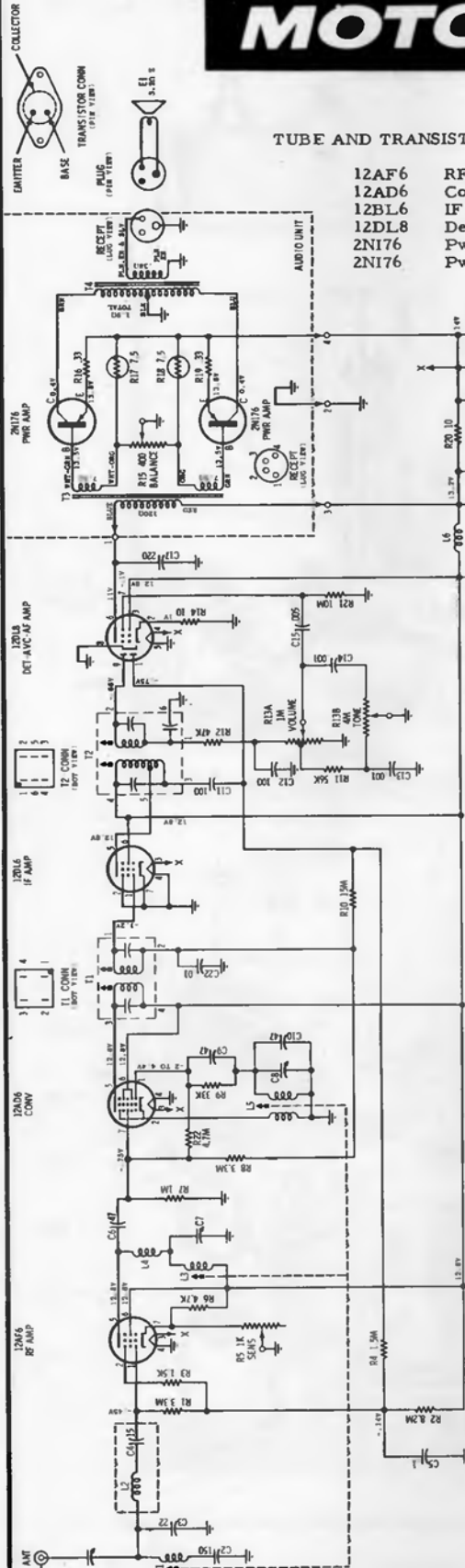

CAUTION  
"A" LEAD MUST BE CONNECTED TO POSITIVE (+) SIDE OF POWER SUPPLY. RADIO WILL NOT OPERATE AND DAMAGE TO COMPONENTS WILL RESULT IF CONNECTED OTHERWISE.

NOTES:  
CAPACITORS - Decimal values in  $\mu F$ , all others in  $M\mu F$  unless otherwise specified.  
TUNING RANGE - 535 KC TO 1610 KC.  
INPUT VOLTAGE - 14.4V DC.  
RESISTORS - Values measured from point indicated to chassis with a VTVM,  $\pm 10\%$ . No signal input.  
Resistances made in Power Amp stage with transistor removed.

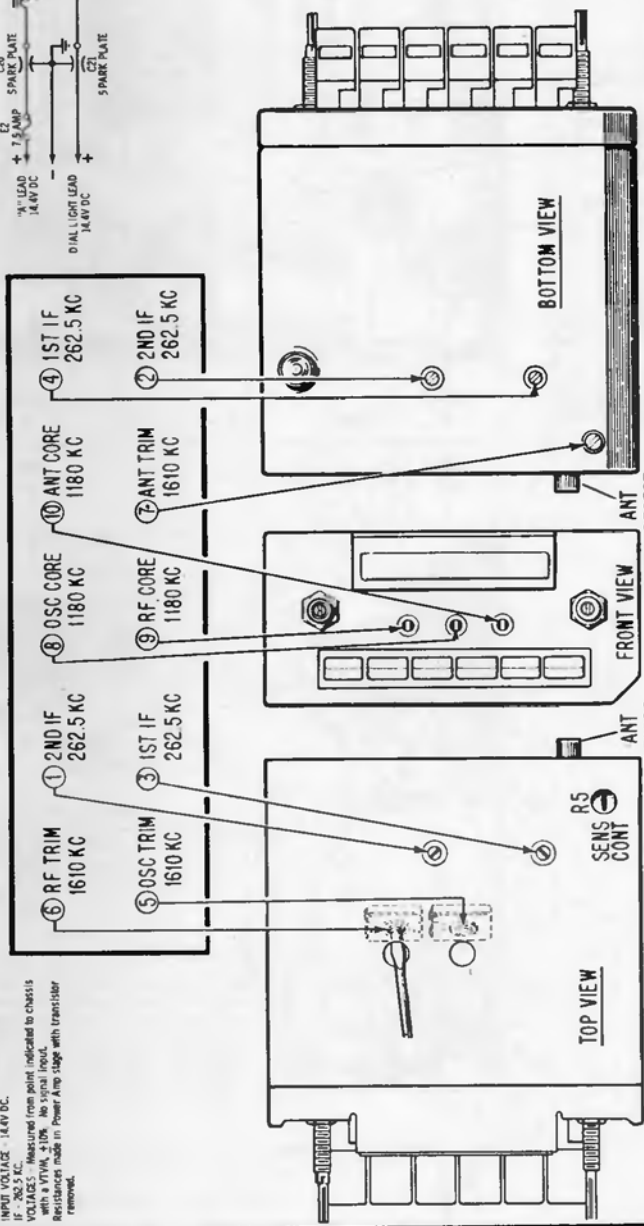

ALIGNMENT ADJUSTMENTS



# MOTOROLA

## AUTO RADIO MODEL

397

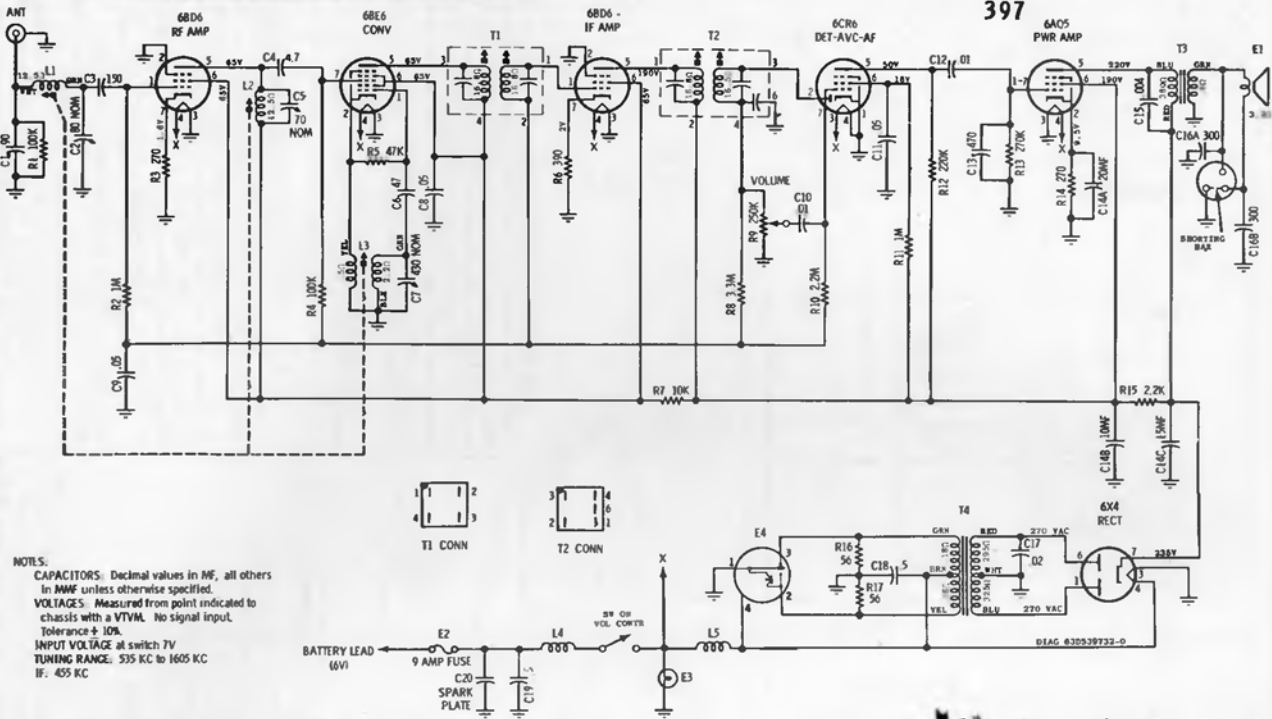

NOTES:  
CAPACITORS: Decimal values in MF, all others in MMF unless otherwise specified.  
VOLTAGES: Measured from point indicated to chassis with a VTVM. No signal input. Tolerance  $\pm 10\%$ .  
INPUT VOLTAGE at switch 7V  
TUNING RANGE: 535 KC to 1605 KC  
IF: 455 KC

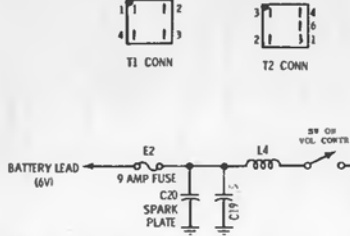

68D6 R3 R2 R5 C4 R15 C8 T1 R4 R6 68D6 E3 C9 R8 T2 R12 6CR6 C12 R11 R9

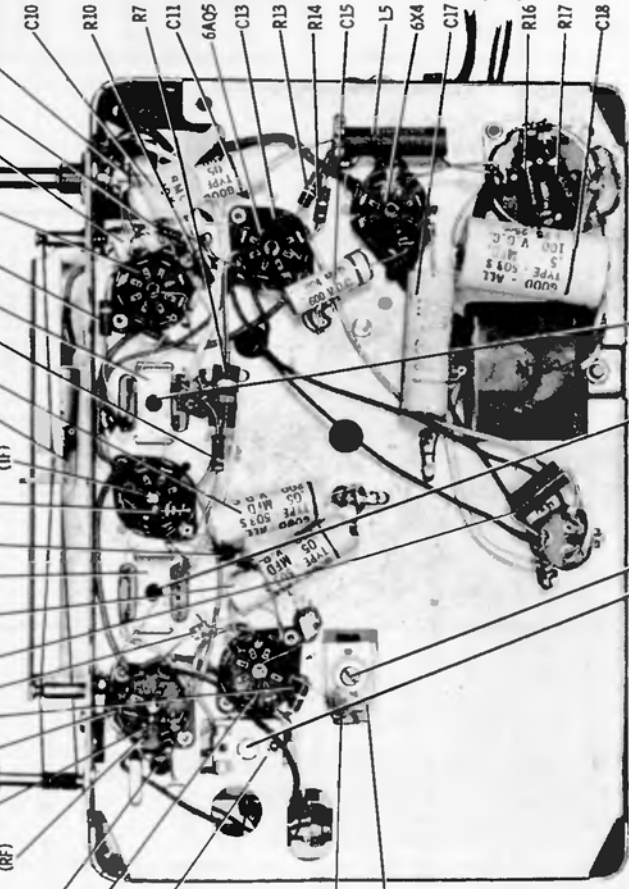

- RF CORE 1400 KC (9)
- ANT CORE 1400 KC (10)
- OSC CORE 1400 KC (8)
- RF TRIM 1610 KC (6)
- OSC TRIM 1610 KC (5)
- ANT TRIM 1610 KC (7)
- 1ST IF 455 KC (1)
- 2ND IF 455 KC (4)
- 1ST IF 455 KC (2)
- 2ND IF 455 KC (3)

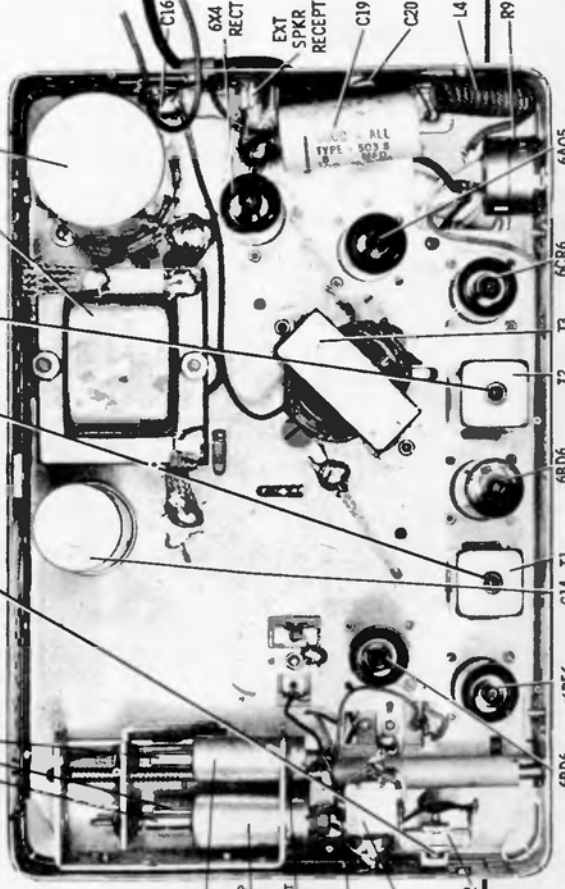

ALIGNMENT ADJUSTMENT & PARTS LOCATIONS

# MOTOROLA

## AUTO RADIO MODEL 398X

(Continued on page 99)

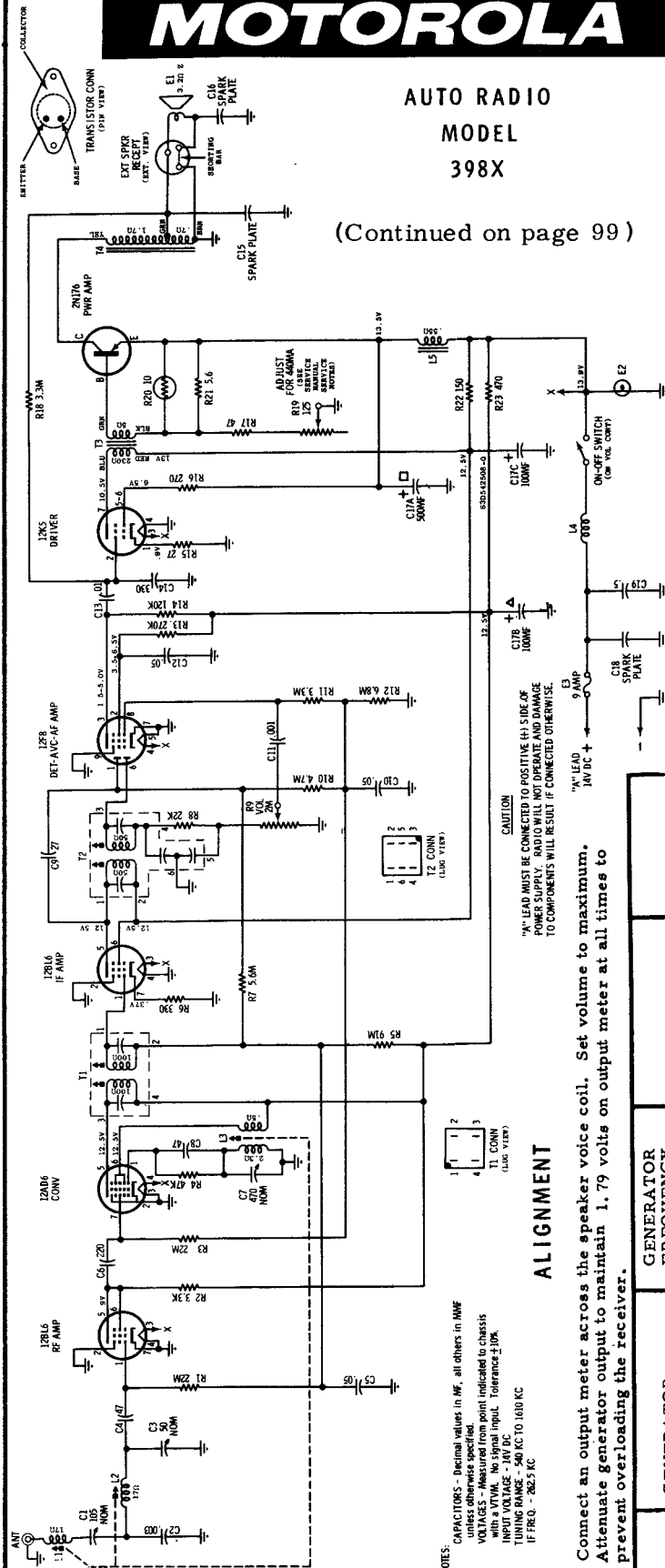

**TRANSISTOR REPLACEMENT** - When replacing a transistor, be sure that the transistor insulator is in place and that the mounting screws are securely tightened. If insulator is not in place the transistor will be shorted to chassis and set will not operate. If mounting screws are not tight, the transistor will be damaged due to lack of proper heat dissipation. **NOTE:** When a transistor is replaced the current should be checked (see SERVICE NOTE 5 and 6).

**TRANSISTOR CURRENT ADJUSTMENT** - After a transistor has been replaced, the collector current should be checked and adjusted for proper operation.

A. Set R-19 to its maximum resistance position (fully counter-clockwise from wiring side) to avoid excessive collector current, then allow radio to warm-up for 15 minutes.  
 B. Open the output transformer T4 (speaker connected) by disconnecting the collector lead (Yel) from the center lug of transistor socket and insert an 0-1 amp DC Ammeter (.05 ohms internal resistance or less): (+) side of meter to lug of transistor socket and (-) to yellow lead of transformer.  
 C. Adjust R-19 for a collector current reading of 360 ma with 12.6 volts input to radio "A" lead.

**NOTE:** Two values of radio input voltage are given as a convenience to service personnel to accommodate different power sources. The schematic collector current value of 440 ma is stated with 14 volts DC input to receiver "A" lead.

### ALIGNMENT

Connect an output meter across the speaker voice coil. Set volume to maximum. Attenuate generator output to maintain 1.79 volts on output meter at all times to prevent overloading the receiver.

STEP	GENERATOR FREQUENCY (400 cycle mod)	TUNER SET TO	ADJUST	REMARKS
1. IF ALIGNMENT	262.5 Kc	Hi end stop	1, 2, 3 & 4	Peak for maximum.
RF ALIGNMENT	1610 Kc	Hi end stop	5, 6 & 7	Peak for maximum.

**NOTE:** Do not perform steps 3, 4, 5 & 6 unless tuner has been tampered with or components have been replaced. Before proceeding with step 3, back tuning cores 1" out of coils to eliminate their effect on trimmer adjustments. Construct core alignment tools as shown below.

3.	Ant receipt through dummy (see Fig.)	Hi end stop	5, 6 & 7	Peak for maximum.
4.	"	13/64" from hi end stop	8, 9 & 10	Peak for maximum.
5.	"	Hi end stop	5, 6 & 7	Peak for maximum.
6.	Repeat steps 4 and 5 until no further increase, then cement tuning cores in place.			

**ANTENNA TRIMMER**

7.	-	Weak station around 1400 Kc	7	With radio installed in car and antenna fully extended, peak antenna trimmer for maximum.
----	---	-----------------------------	---	---

- NOTES:** CAPACITORS - Decimal values in MF, all others in MMF unless otherwise specified.  
 VOLTAGES - Measured from point indicated to chassis with a VTVM. No signal input. Tolerance  $\pm 10\%$ .  
 TUNING RANGE - 540 KC TO 1600 KC  
 IF FREQ. - 262.5 KC



**MOTOROLA**

Model 398X  
(Continued from page 98)

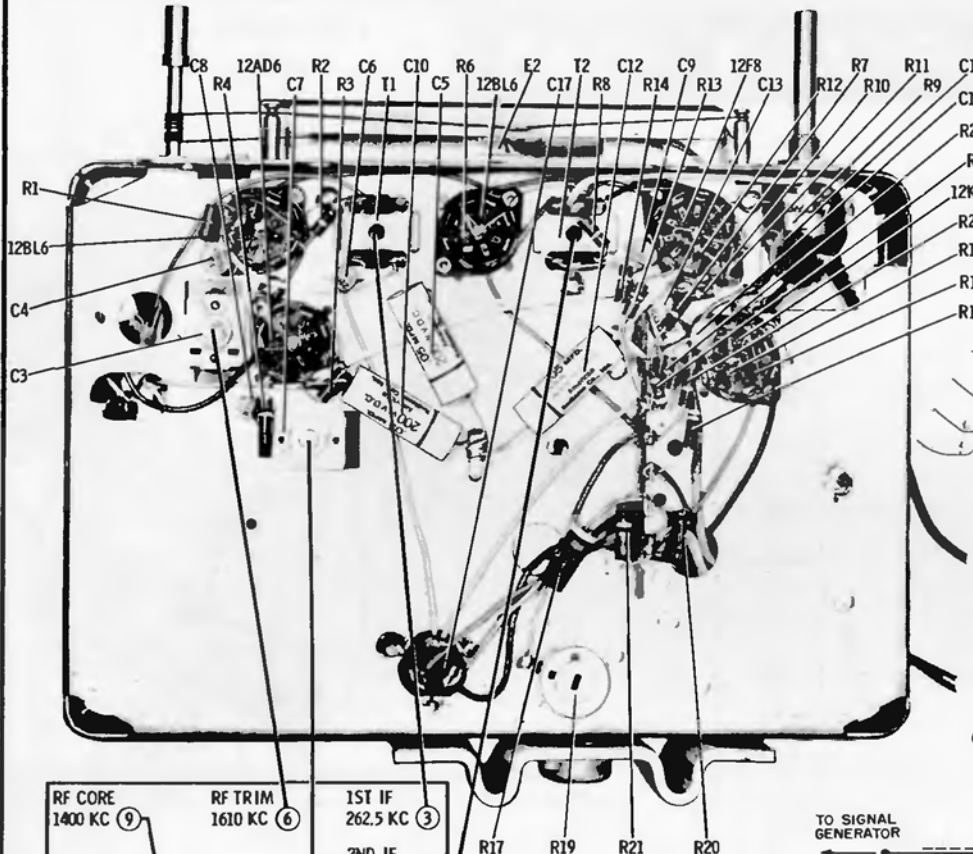

- |                          |                         |                        |
|--------------------------|-------------------------|------------------------|
| RF CORE<br>1400 KC (9)   | RF TRIM<br>1610 KC (6)  | 1ST IF<br>262.5 KC (3) |
| ANT CORE<br>1400 KC (10) | OSC TRIM<br>1610 KC (5) | 2ND IF<br>262.5 KC (2) |
| OSC CORE<br>1400 KC (8)  | ANT TRIM<br>1610 KC (7) | 2ND IF<br>262.5 KC (1) |
|                          |                         | 1ST IF<br>262.5 KC (4) |

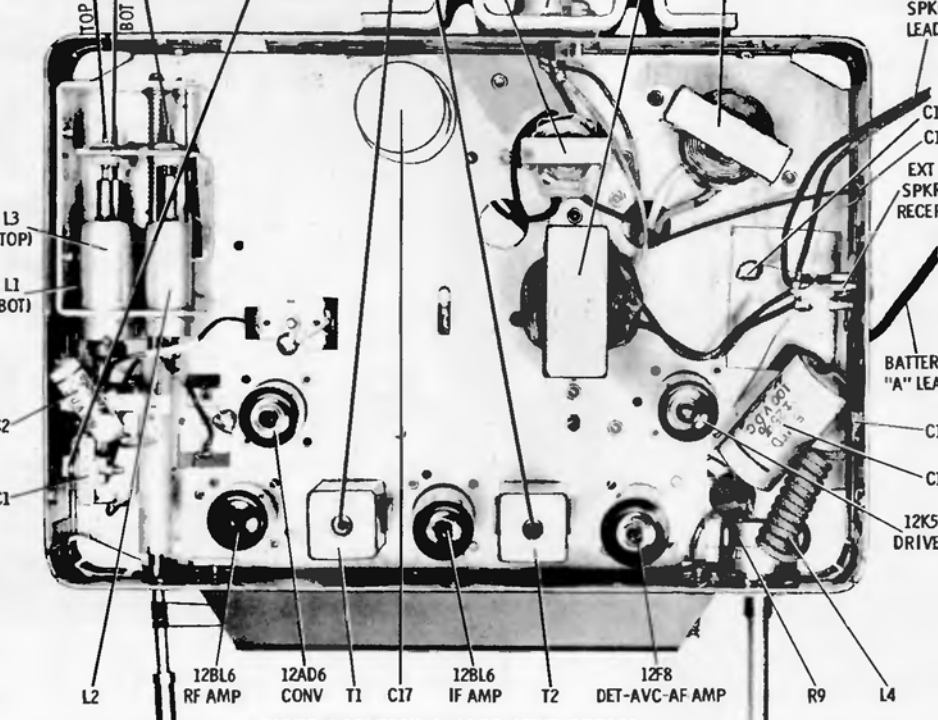

PARTS LOCATION & ALIGNMENT DETAIL

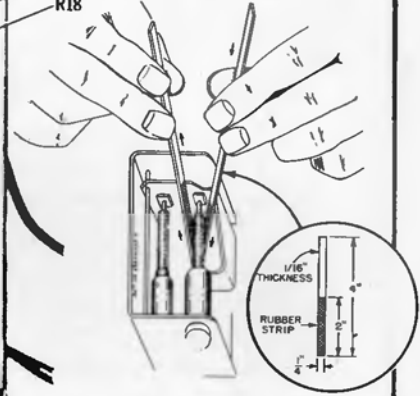

CORE ALIGNMENT TOOL DETAIL

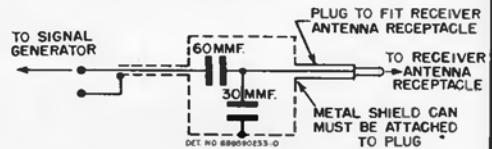

DUMMY ANTENNA DETAIL

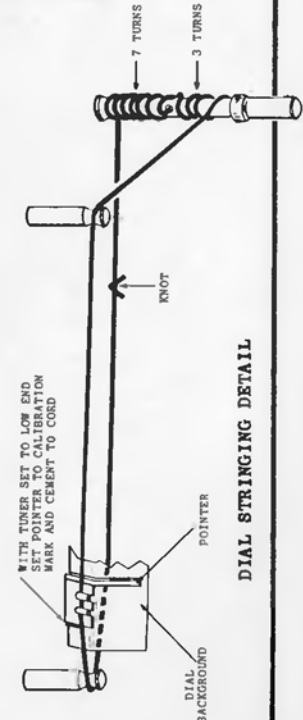

DIAL STRINGING DETAIL

# MOTOROLA

AUTO RADIO  
MODEL  
397X

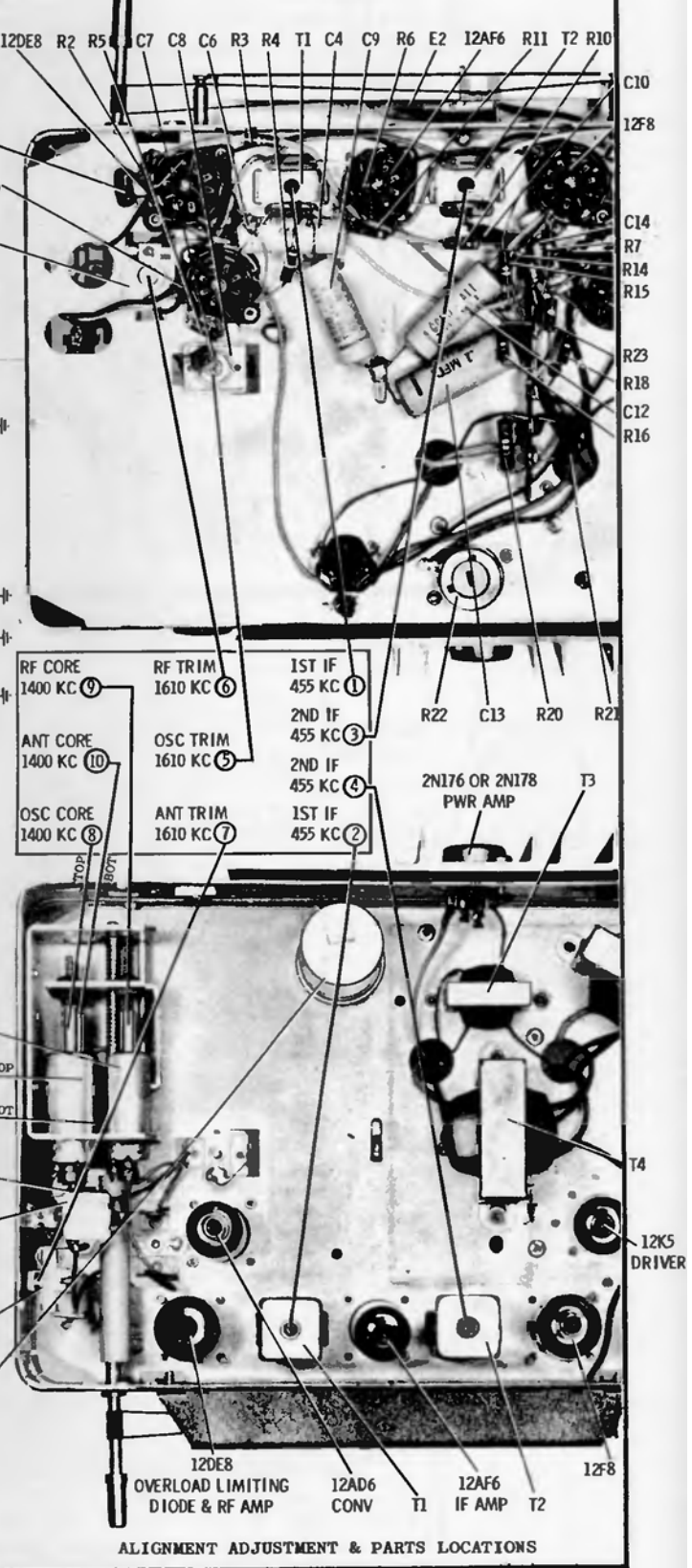
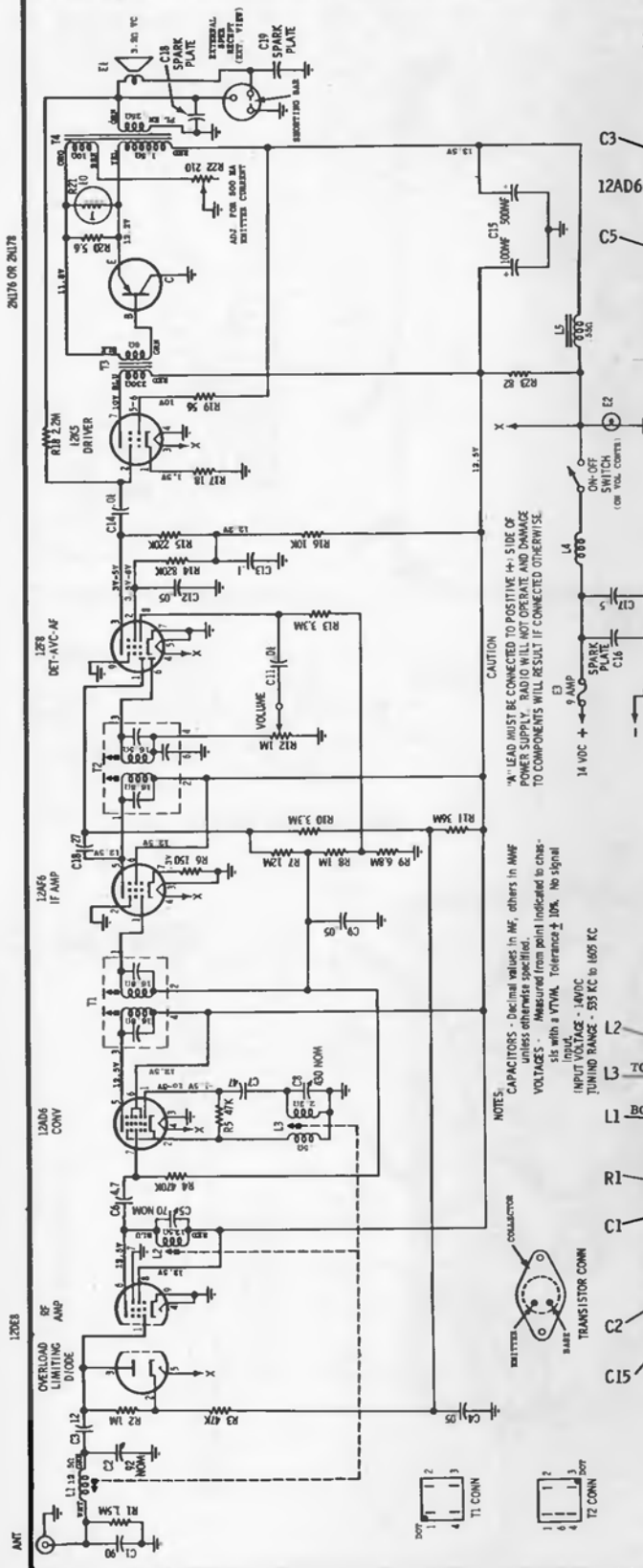

CAUTION  
\*A LEAD MUST BE CONNECTED TO POSITIVE + SIDE OF POWER SUPPLY. RADIO WILL NOT OPERATE AND DAMAGE TO COMPONENTS WILL RESULT IF CONNECTED OTHERWISE.

NOTES:  
CAPACITORS - Decimal values in MF, others in MMF unless otherwise specified.  
VOLTAGES - Measured from point indicated to chassis with a VTVM. Tolerance  $\pm 10\%$ . No signal.  
INPUT VOLTAGE - 14VDC  
TUNING RANGE - 555 KC to 1605 KC

ALIGNMENT ADJUSTMENT & PARTS LOCATIONS

# MOTOROLA

MODELS

- 597X
- BKA6X
- BKA7X
- CTA6X
- CTA7X
- PCA7X

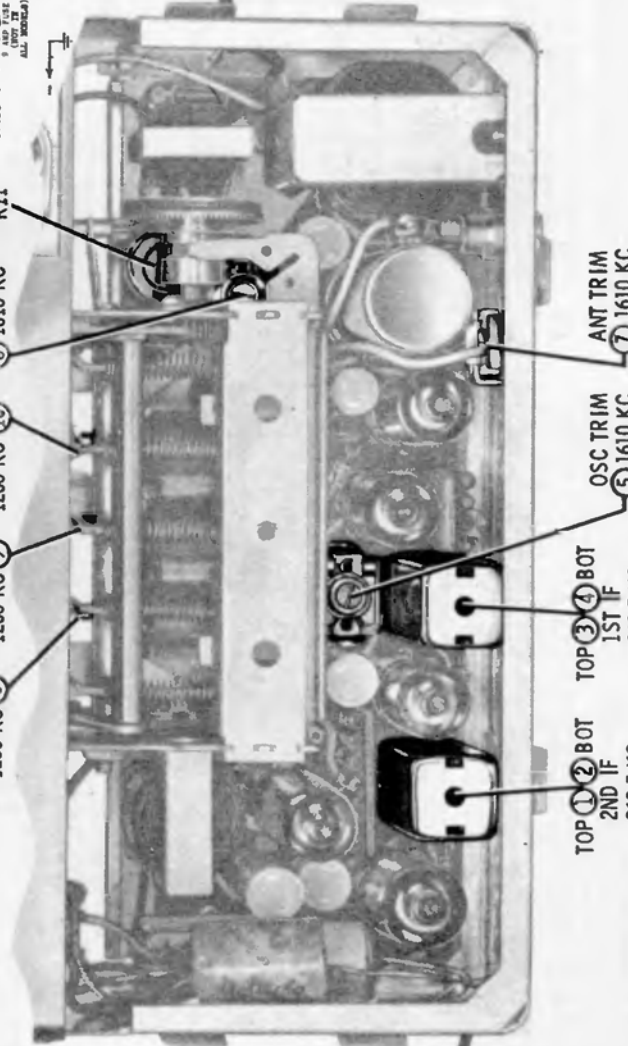
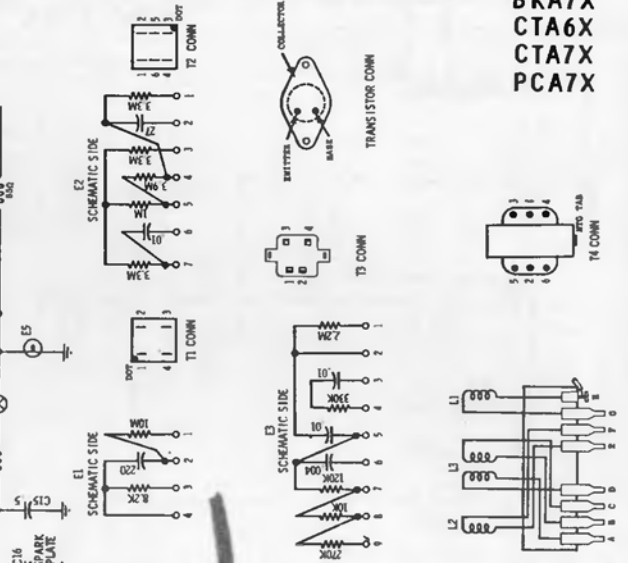
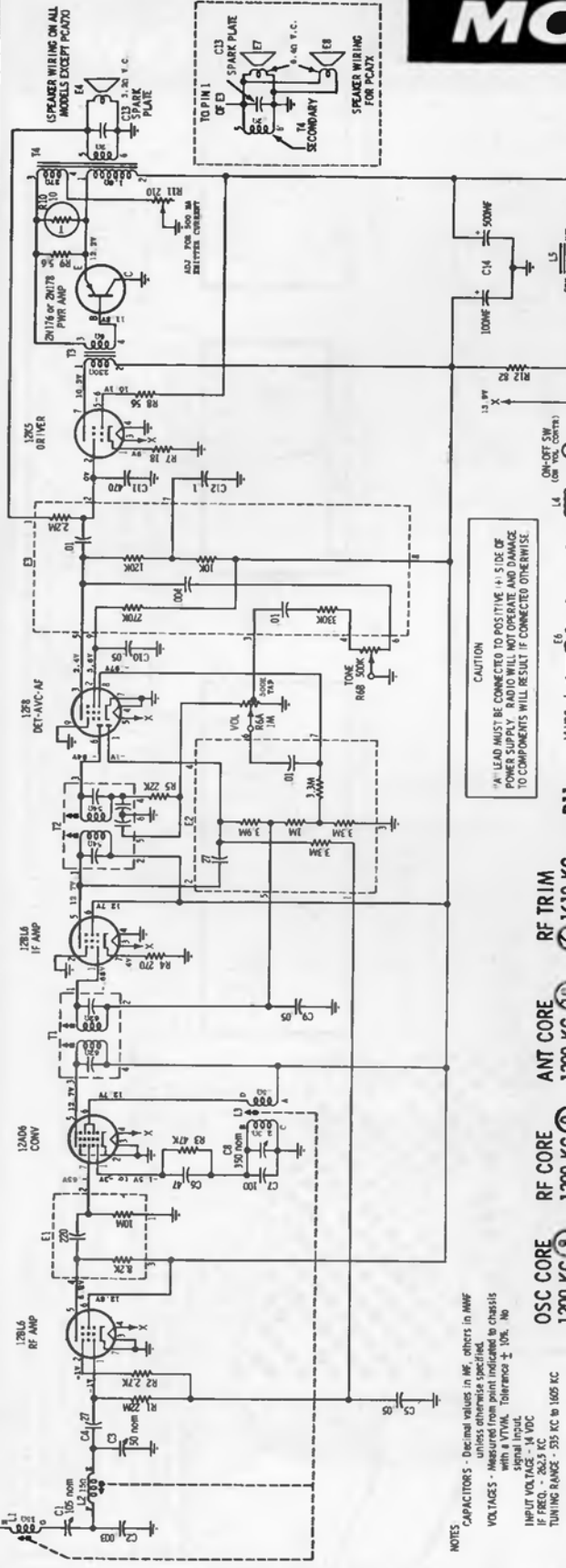

NOTES  
 CAPACITORS - Decimal values in MF, others in µMF  
 VOLTAGES - Measured from point indicated to chassis with a VTVM. Tolerance ± 10%. No signal input.  
 INPUT VOLTAGE - 14 VDC  
 IF FREQ. - 262.5 KC  
 TUNING RANGE - 535 KC to 1605 KC

ALIGNMENT POINTS

# MOTOROLA

Model 600X

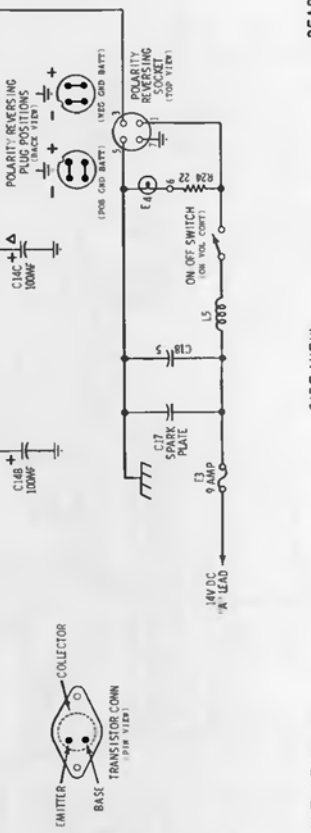
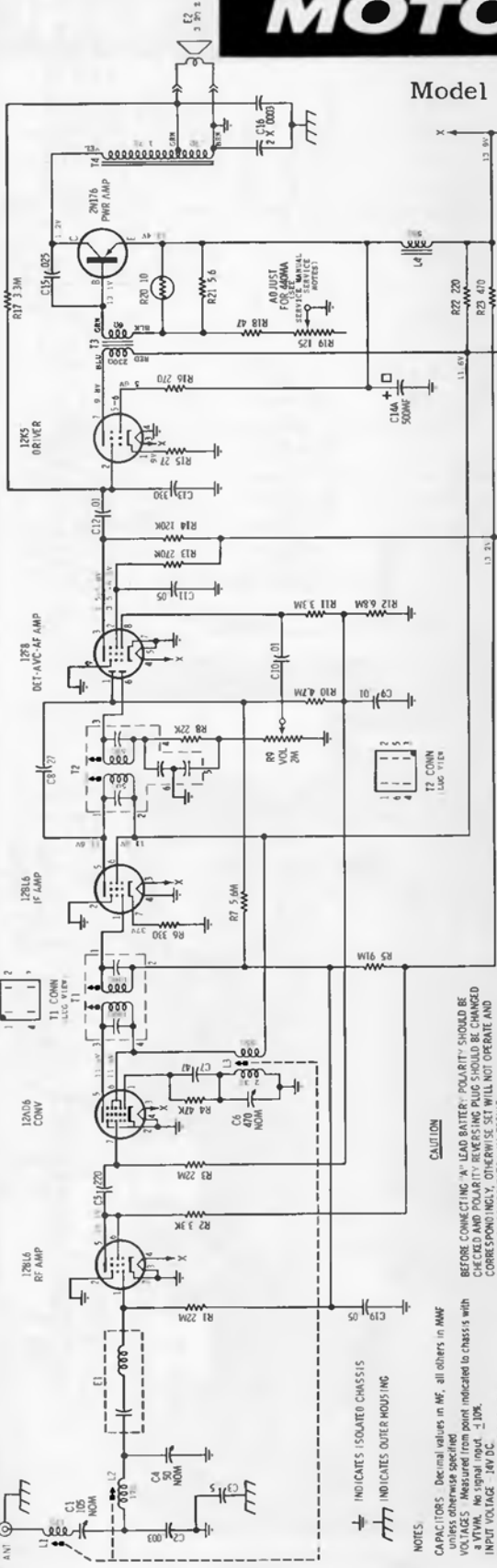

**CAUTION**  
BEFORE CONNECTING "A" LEAD BATTERY, POLARITY SHOULD BE CHECKED AND SPARK PLATE SHOULD BE CHANGED TO POSITIVE POSITION. OTHERWISE, SET WILL NOT OPERATE AND DAMAGE TO COMPONENTS WILL RESULT.

**NOTES:**  
CAPACITORS: Decimal values in MF, all others in MMF unless otherwise specified.  
VOLTAGES: Measured from point indicated to chassis with 500KΩ, no signal input, ±10%.  
TUNING RANGE: 535 KC TO 1605 KC.  
IF: FREQ. - 262.5 KC.

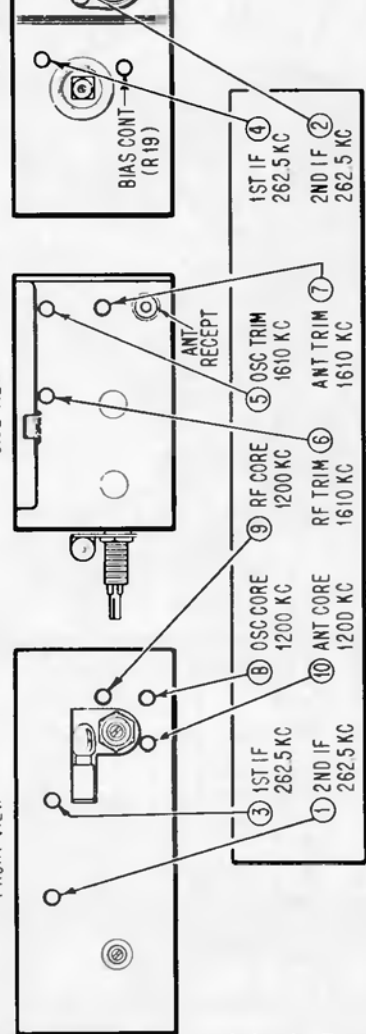

ALIGNMENT ADJUSTMENTS

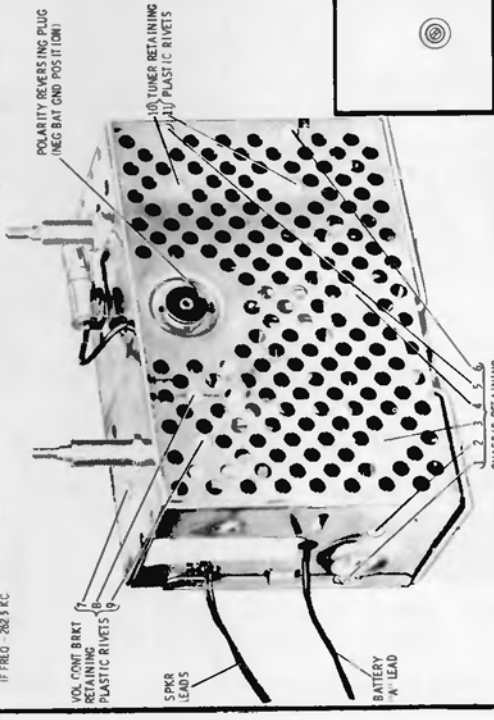

**CHASSIS REMOVAL**

- A. Remove cover and back plate.
- B. Remove chassis retainer plastic rivets 1, 2, 3, 4, 5 and 6 (see photo) by carefully pushing out center pin and then remove plastic rivet.
- C. Unsolder chassis leads to Polarity Reversing Socket.
- D. Unsolder chassis leads to mica capacitor (C16).
- E. Unsolder chassis leads going to antenna receptacle and volume control.
- F. Unsolder chassis leads to tuner.
- G. Remove chassis.

# MOTOROLA

Model 852, used in Dodge cars  
 Model 853, used in DeSoto cars  
 Model 854, used in Plymouth cars

Circuit diagram is exact for Model 854. Models 852 and 853 are similar electrically to Model 854.

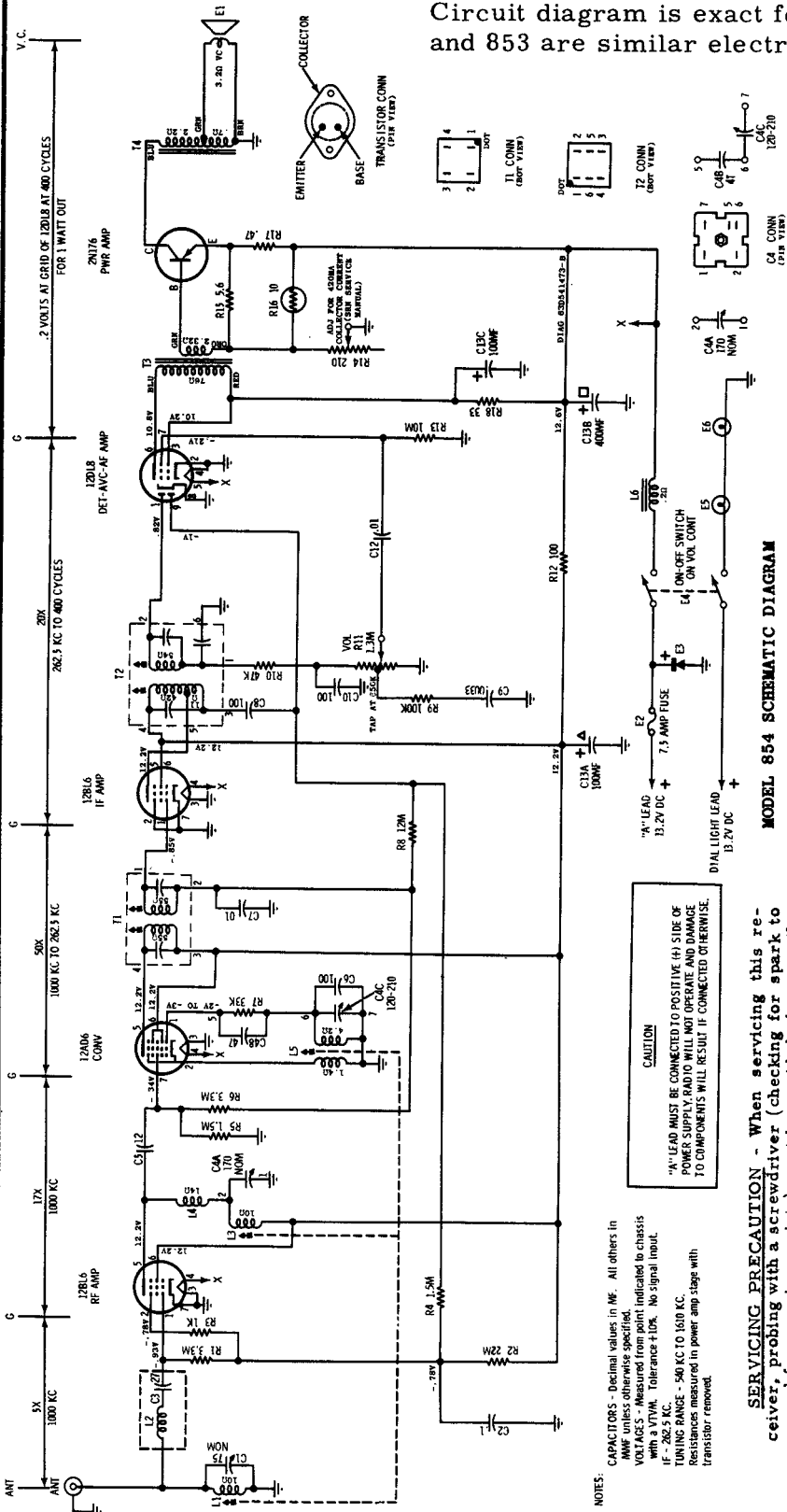

Model 852	Dodge	LD1, LD2, LD3
Model 853	DeSoto	LS1, LS2, LS3
Model 854	Plymouth	LPI, LP2

MODEL 854 SCHEMATIC DIAGRAM

- Connect a VTVM from collector electrode (transistor shell) to chassis.
  - Adjust R-14 for .85 volts on VTVM. (this corresponds to a collector current of 425 Ma.)
  - Repeat step b after a half-hour.
- TRANSISTOR REPLACEMENT** - When replacing a transistor, be sure that the transistor insulator is in place and that the mounting screws are securely tightened. If insulator is not in place the transistor will be shorted to chassis and set will not operate. If mounting screws are not tight, the transistor will be damaged due to a lack of proper heat dissipation.
- TRANSISTOR CURRENT ADJUSTMENT** - After replacing transistor and before connecting radio to power supply, set the transistor bias control (R-14) to the maximum (fully counter-clockwise) position to prevent excessive current from damaging the transistor. Allow about 15 minutes warm-up time before proceeding with the following:
- TRANSISTOR INSULATOR** - When replacing a transistor or transistor insulator, be sure to coat both sides of insulator with DC-4 grease (Motorola Part No. 11M490487) to insure proper heat dissipation.
- TRANSISTOR CHECK** - Substituting a known good transistor for a suspected one is the simplest and most positive method of checking transistors. NOTE: When checking, be sure transistor insulator is in place (see SERVICE NOTE 6).
- TUBE CHECK** - Substituting a known good tube for a suspected one is the best and only check recommended at this time.

**NOTES:**  
 CAPACITORS - Decimal values in  $\mu$ F. All others in  $\mu$ MFD unless otherwise specified.  
 VOLTS AC TYP. Measured from 100K. No signal input.  
 IF - 262.5 KC. Tolerance  $\pm 1.0\%$ .  
 TUNING RANGE - 540 KC TO 1630 KC.  
 Resistances measured in power amp stage with transistor removed.

# MOTOROLA

Model MoPar 923  
(Continued on page 105)

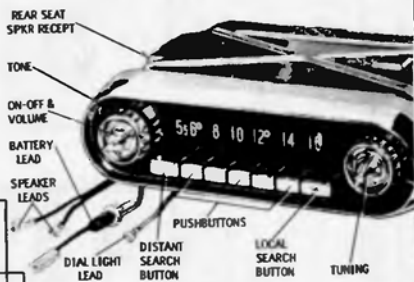
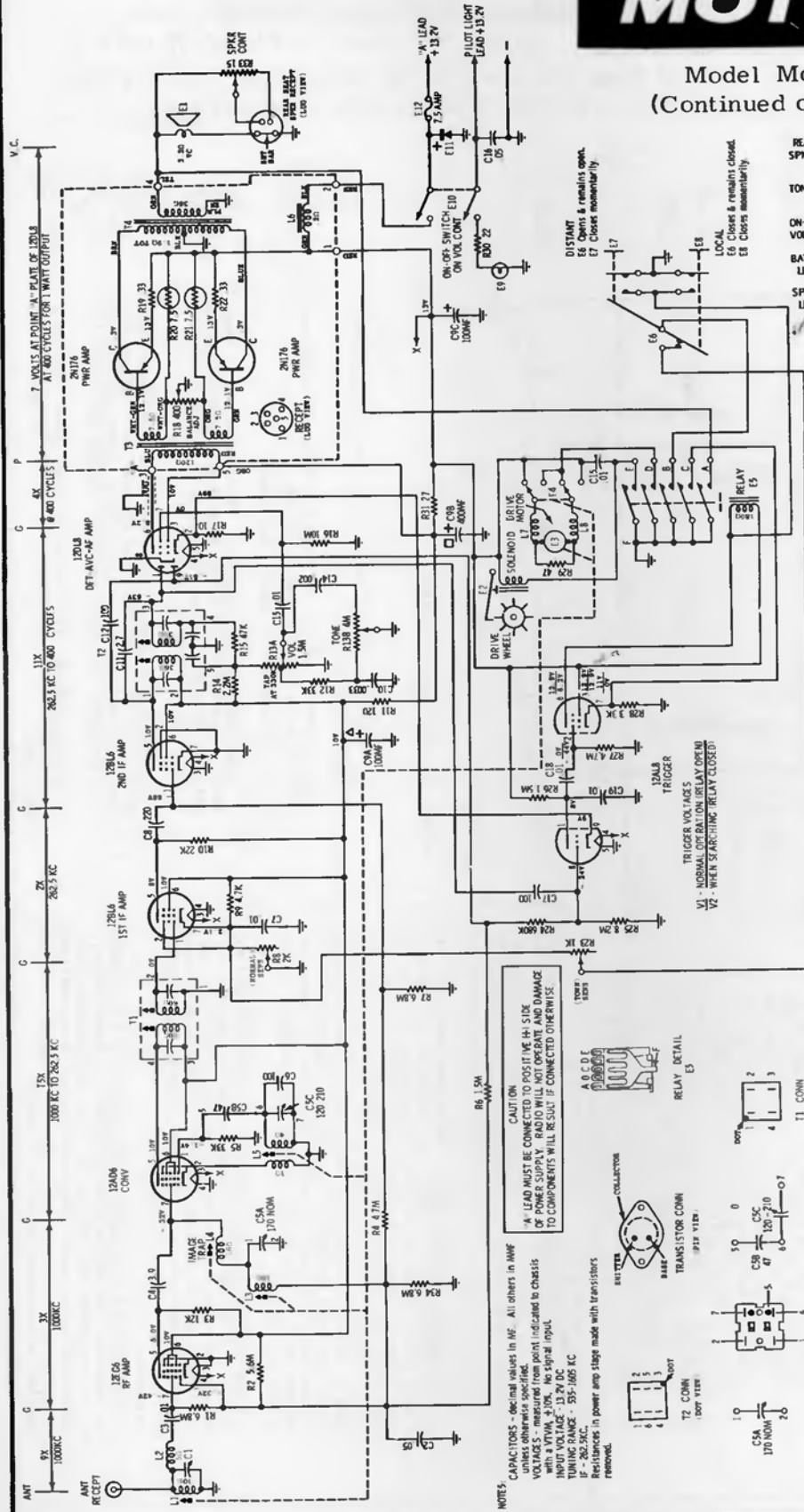

- TRIGGER VOLTAGES**  
 V1 - NORMAL OPERATION (RELAY OPEN)  
 V2 - WHEN SEARCHING (RELAY CLOSED)
- SERVICE NOTES**
- TRANSISTOR REPLACEMENT** - When replacing a transistor, be sure that the transistor insulator is in place and that the mounting screws are securely tightened. If insulator is not in place the transistor will be shorted to chassis and set will not operate. If mounting screws are not tight, the transistor will be damaged due to lack of proper heat dissipation. NOTE: When a transistor is replaced the current should be checked (see SERVICE NOTE 6 and 7).
  - TRANSISTOR CURRENT ADJUSTMENT** - After replacing transistor and before connecting radio to power supply, set the transistor balance control R-18 to the mid-position to prevent excessive current from damaging the transistors. Allow about 15 minutes warm-up time before proceeding with the following:
    - Connect a VTVM across the two ends of balance adjustment control R-18; be sure VTVM is accurately zeroed and set to a low voltage scale. NOTE: If VTVM has a center zero scale, use center zero scale.
    - Adjust R-18 for zero reading on VTVM.
  - TRANSISTOR INSULATOR** - When replacing a transistor or transistor insulator, be sure to coat both sides of insulator with DC-4 grease (Motorola Part No. 11M490487) to insure proper heat dissipation.
  - TRANSISTOR CHECK** - Substituting a known good transistor for a suspected one is the simplest and most positive method of checking transistors. NOTE: When checking, be sure transistor insulator is in place (see SERVICE NOTE 7).
  - TUBE CHECK** - Substituting a known good tube for a suspected one is the best and only check recommended at this time.

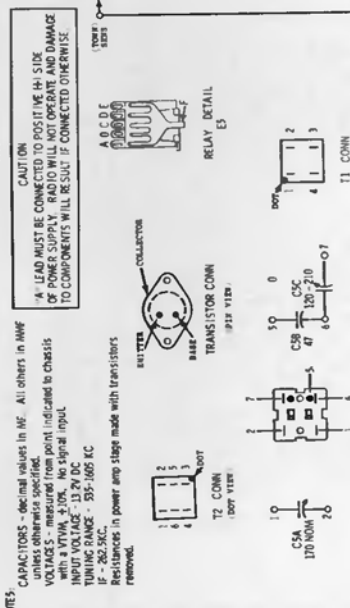

NOTES:  
 CAPACITORS - decimal values in MF. All others in MMF unless otherwise specified.  
 RESISTORS - values in ohms unless indicated to be in kilohms (K) or megohms (M).  
 INPUT VOLTAGE - 13.2V DC  
 TUNING RANGE - 535-1605 KC  
 IF - 455.5 KC  
 Resistances in power amp stage made with transistors removed.



MOTOROLA Model MoPar 923 (Continued from page 104)

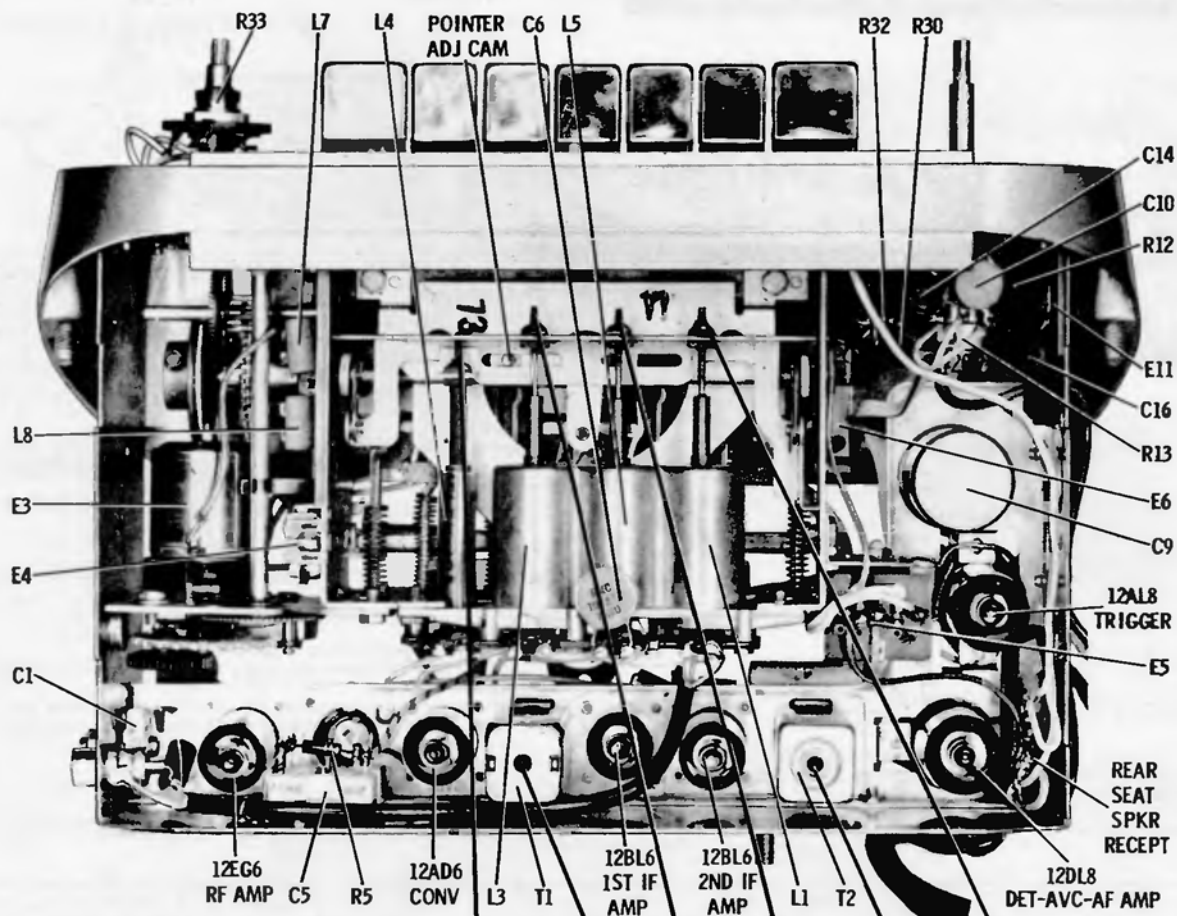

7	ANT TRIM 1610 KC	OSC TRIM 1610 KC	RF TRIM 1610 KC	11	IMAGE CORE 1925 KC	3	1ST IF 262.5 KC	9	RF CORE 1020 KC	8	OSC CORE 1020 KC	1	2ND IF 262.5 KC	10	ANT CORE 1020 KC
		5	6			4						2			

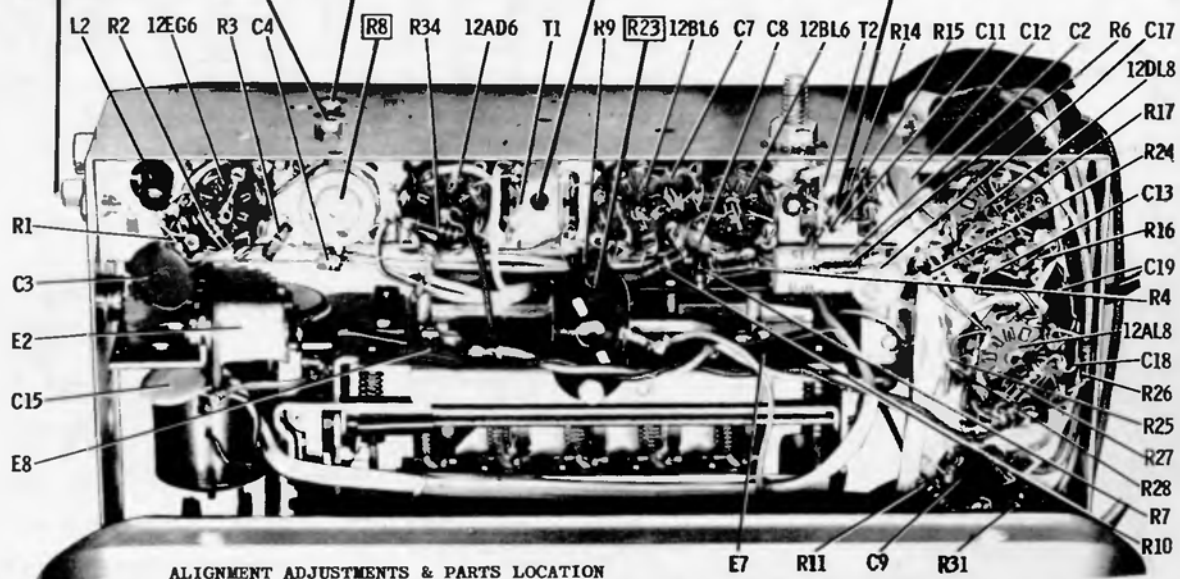

ALIGNMENT ADJUSTMENTS & PARTS LOCATION

# MOTOROLA

CHASSIS  
HS-598

MODELS  
2F21B  
2F21R

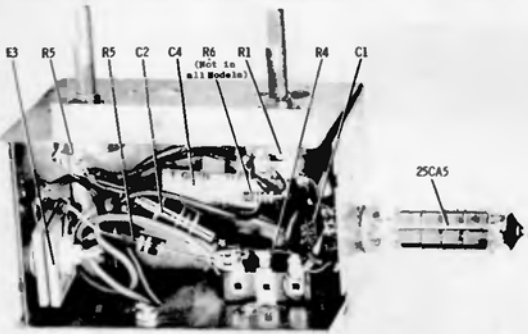

PARTS LOCATION

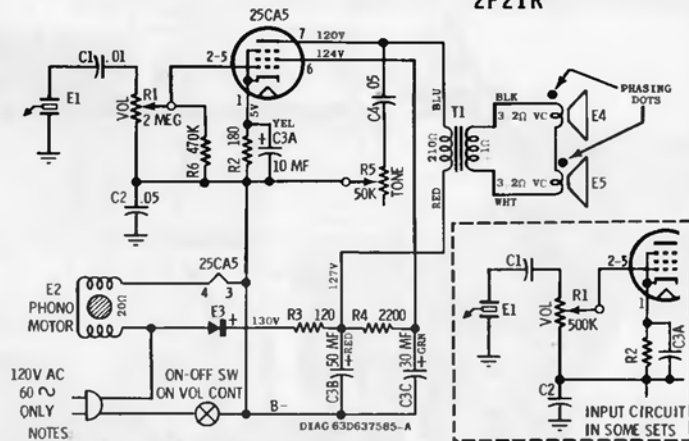

Capacitors - decimal values in MF all others in MMF unless otherwise specified.  
Voltages - measured from point indicated to B- with a VTVM.

### DISASSEMBLY INSTRUCTIONS

#### To Remove Chassis from Cabinet

1. Pull off two knobs from front of cabinet.
2. Remove four (4) phono mounting board and two (2) baffle retainer screws.
3. Lift rear of phono mounting board slightly and slide out.
4. Remove two screws which hold chassis to mounting board and remove chassis.

#### To Remove Turntable

1. Remove "C" washer from spindle.
2. Remove turntable by pulling up - off of spindle.

### SPEAKER PHASING

NOTE: THE SPEAKERS MUST BE PHASED OR A LOSS OF THE LOW FREQUENCIES WILL RESULT

Phasing can be checked by momentarily connecting a 1-1/2 volt flashlight cell in parallel with the output transformer secondary and noting that the cones of all speakers move in the same direction. If they do not, reverse the connections of one speaker.

## MOTOROLA Chassis HS-599, Model 3F22

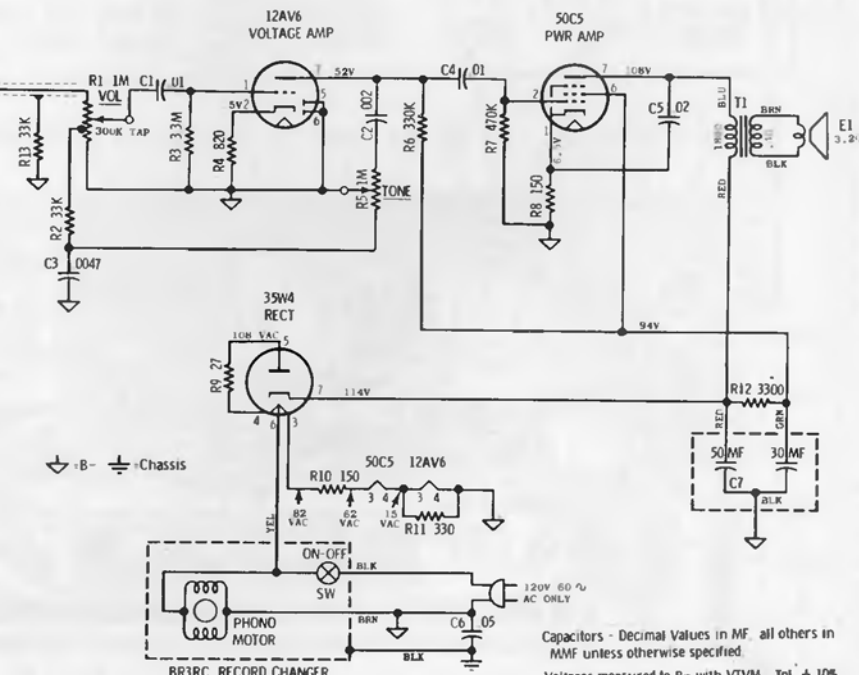
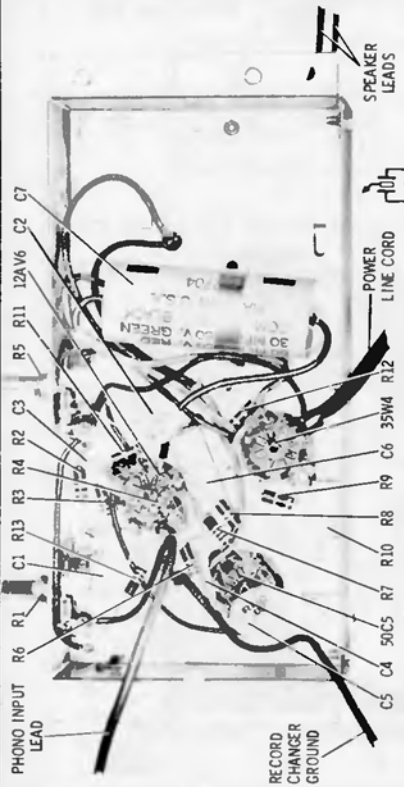

Capacitors - Decimal Values in MF, all others in MMF unless otherwise specified.  
Voltages measured to B- with VTVM. Tol. ± 10%

**MOTOROLA**

**CHASSIS**  
HS-601  
HS-602

**MODELS**  
3H24B-1  
3H24B-2  
3H24S-1  
3H24S-2  
3H25B  
3H25B-1  
3H25M  
3H25M-1

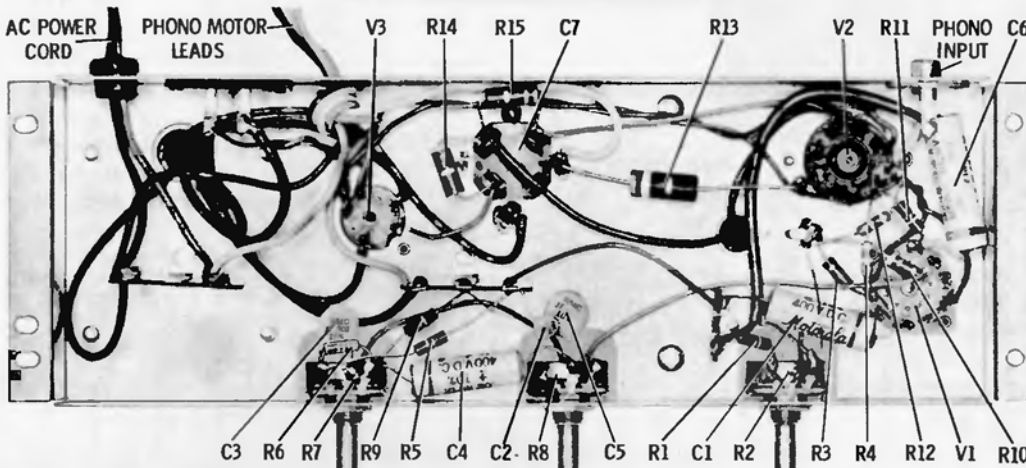

**PARTS LOCATION - BOTTOM VIEW OF CHASSIS (EARLY VERSION)**

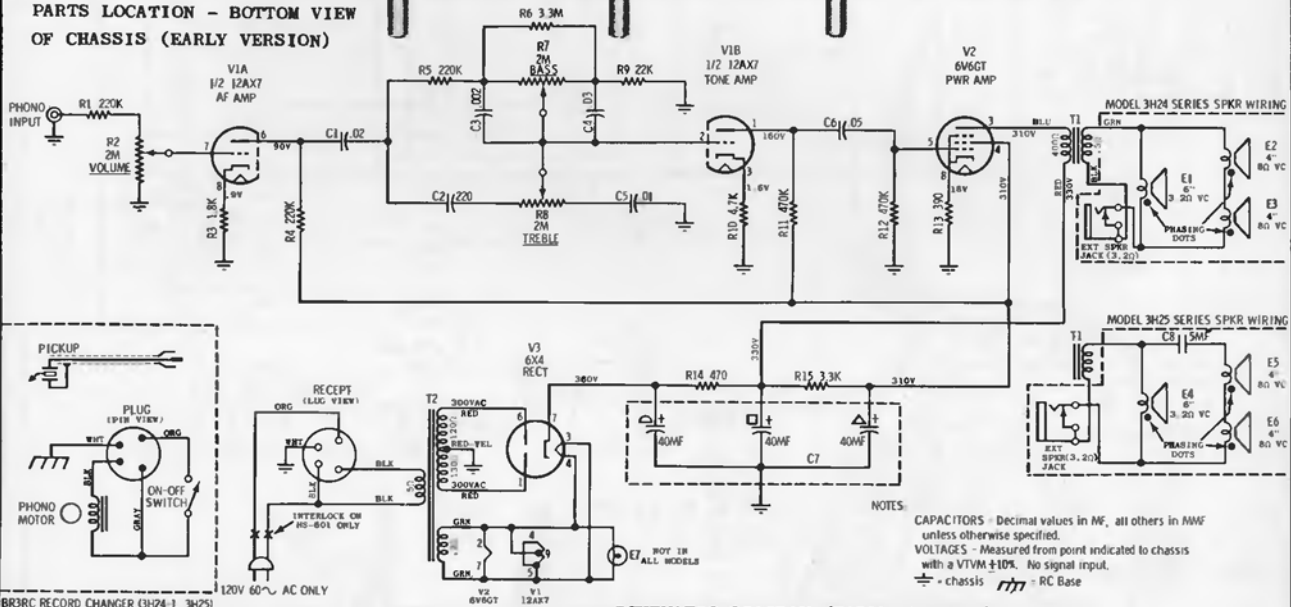

**SCHEMATIC DIAGRAM (EARLY VERSION)**

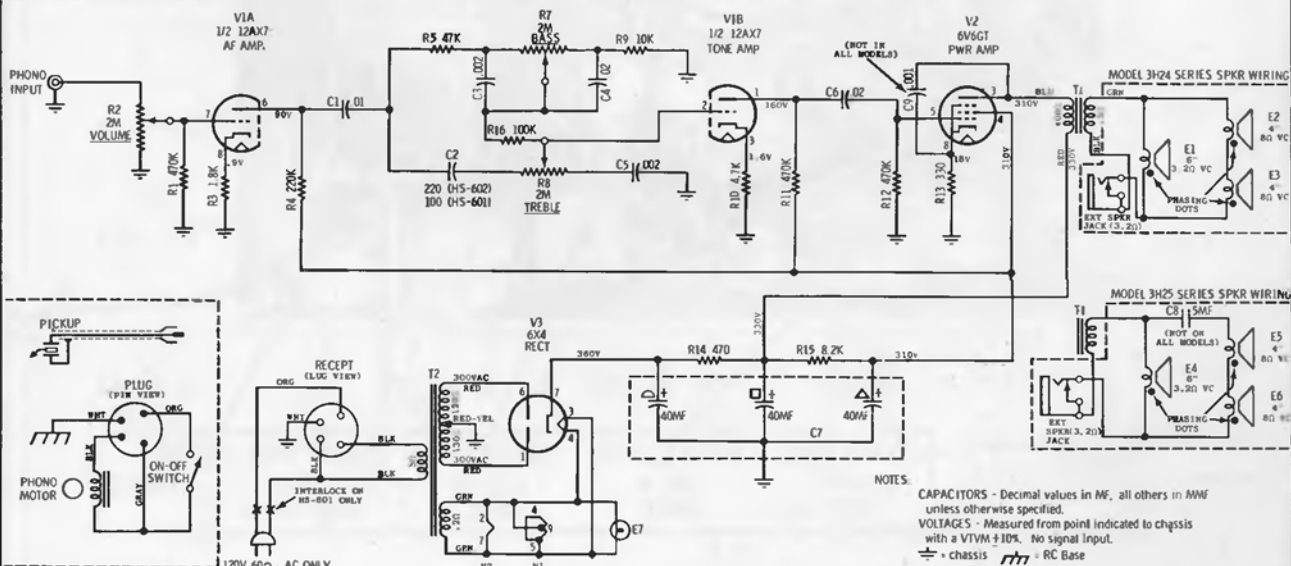

**SCHEMATIC DIAGRAM (LATE VERSION)**

**NOTES:**  
CAPACITORS - Decimal values in MF, all others in MMF unless otherwise specified.  
VOLTAGES - Measured from point indicated to chassis with a VTVM  $\pm 10\%$ . No signal input.  
- chassis  $\text{---}$  RC Base

**NOTES:**  
CAPACITORS - Decimal values in MF, all others in MMF unless otherwise specified.  
VOLTAGES - Measured from point indicated to chassis with a VTVM  $\pm 10\%$ . No signal input.  
- chassis  $\text{---}$  RC Base

**MOTOROLA**

MODELS	CHASSIS
5C22M	HS-578
5C22N	HS-578
5C22P	HS-578
5C22W	HS-578
5C22Y	HS-578
5C23CW	HS-579
5C23GW	HS-579
5C23PW	HS-579

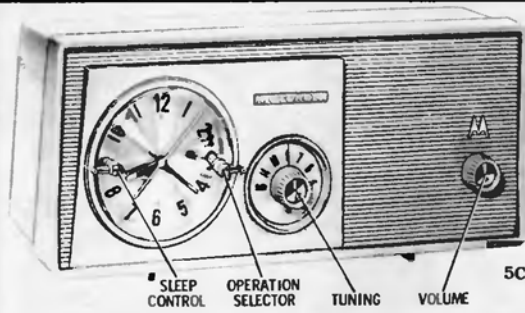

5C23 SERIES

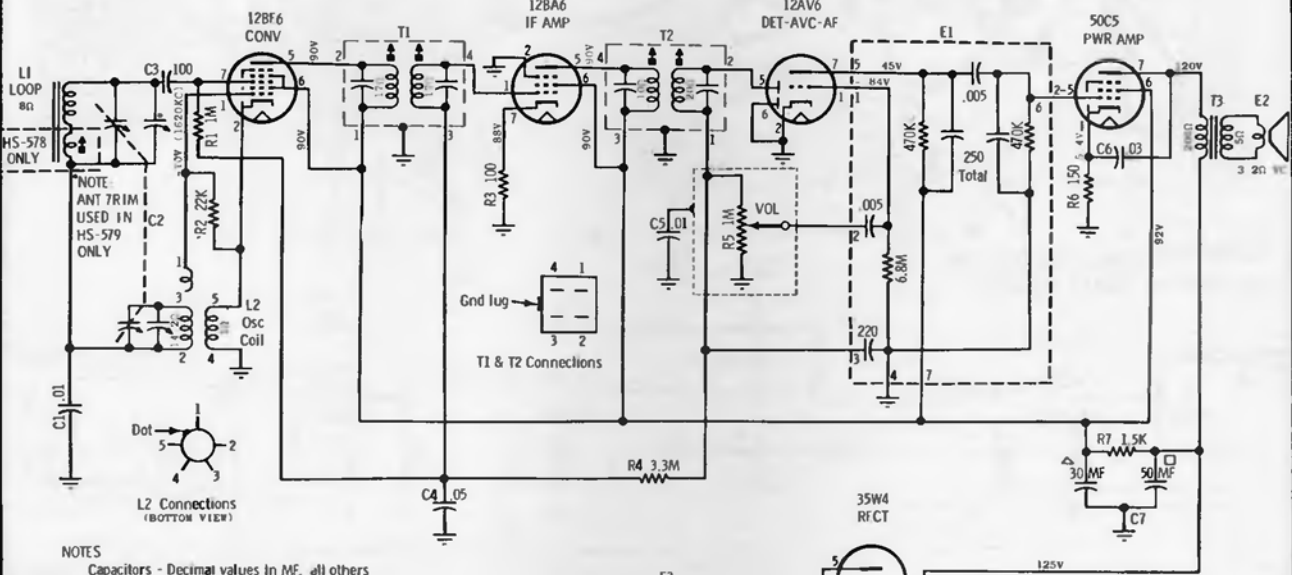

NOTES

Capacitors - Decimal values in MF, all others in MMF unless otherwise specified.

Voltages - Measured from point indicated to ground with a VTVM. No signal input.

Input Voltage - 120V AC  $\pm$  10%.

Tuning Range - 535 to 1620 KC.  
IF - 455 KC.

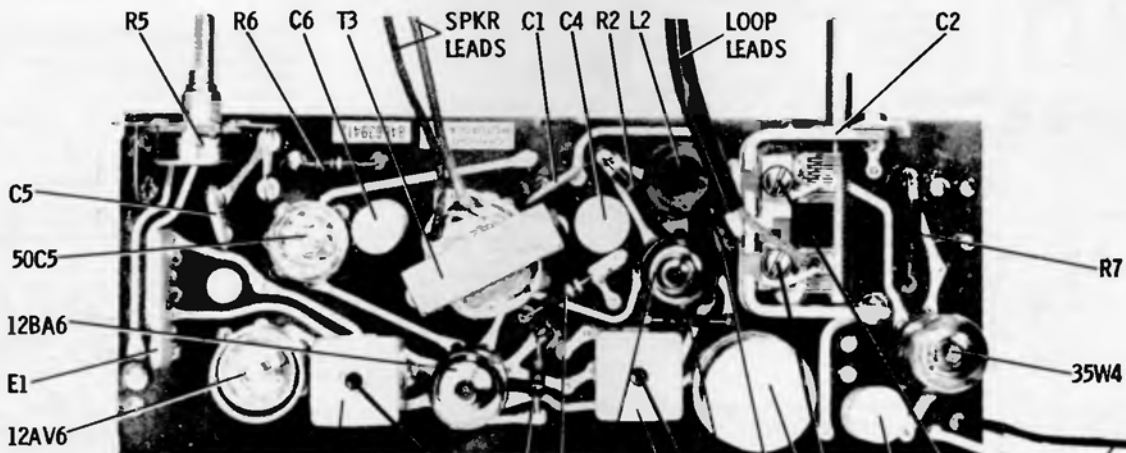
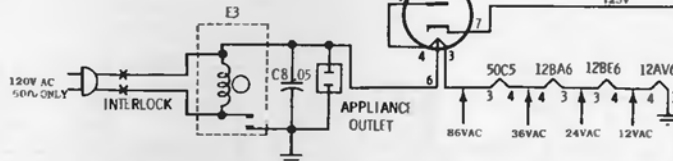

ANTENNA CIRCUIT  
INDUCTANCE ADJUSTMENT

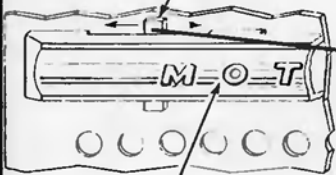

FERRITE LOOP ANTENNA

6	ANT CORE	TOP	1	2	BOT	TOP	3	4	BOT	7	ANT TRIM	5	OSC
	600KC				455KC				455KC		1400KC		1620KC
	(5C22 ONLY)										(5C23 ONLY)		

ALIGNMENT ADJUSTMENTS AND PARTS LOCATIONS

# MOTOROLA

MODELS	CHASSIS
5K21B, M	HS-608
5K21B-A, M-A	HS-632
5K23B-1, CW-1, M-1	HS-608
5K23B-1A, CW-1A, M-1A	HS-632

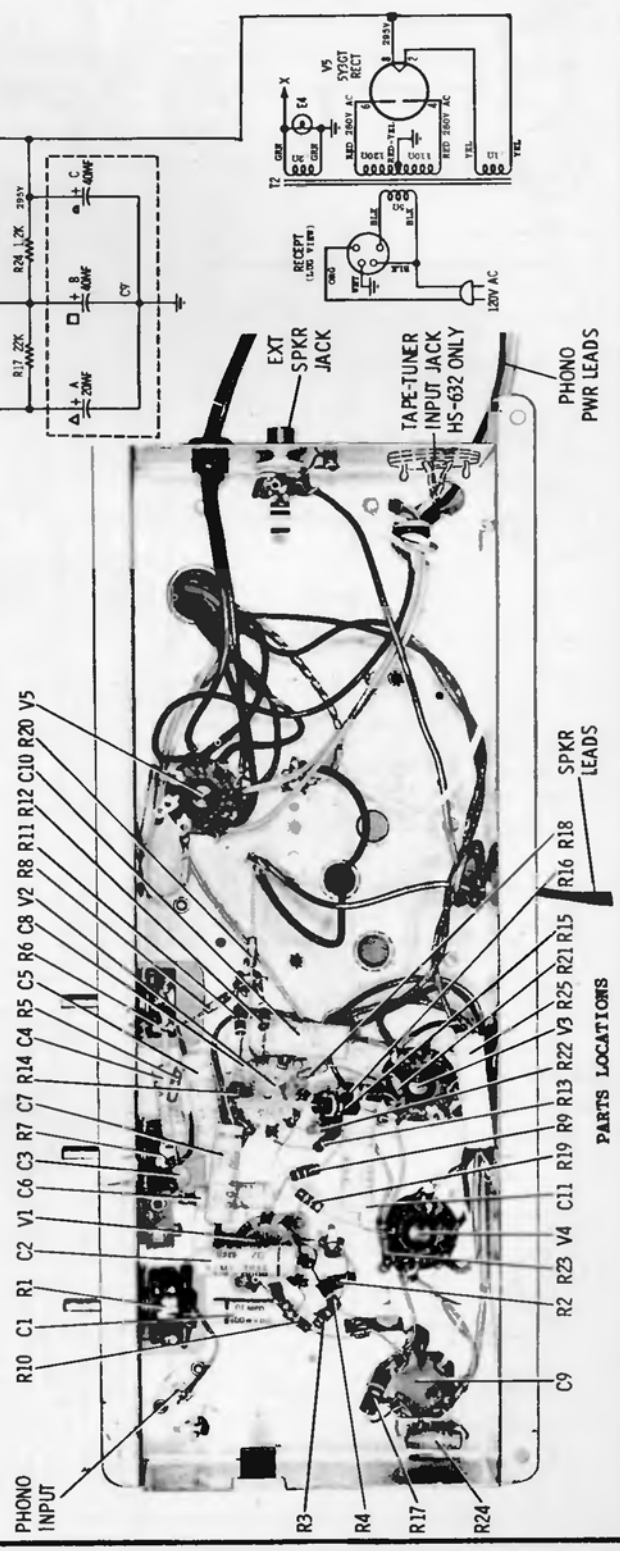
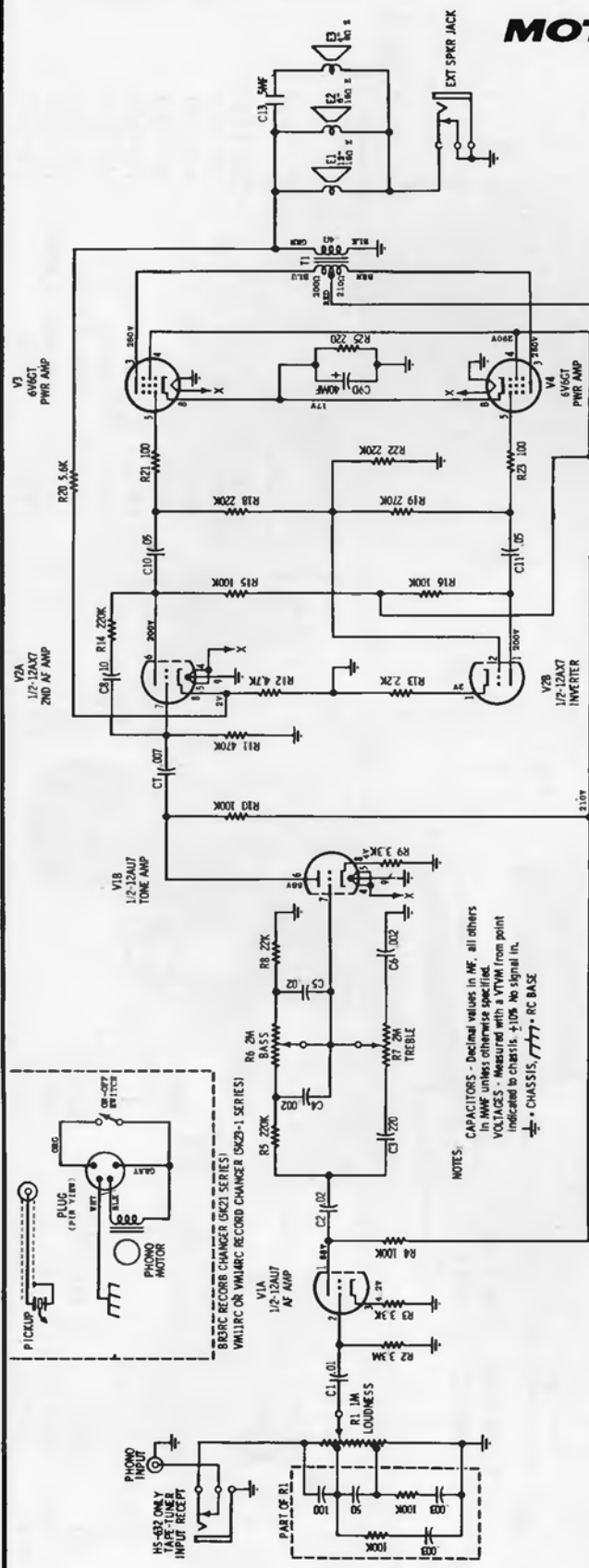

NOTES:  
 CAPACITORS - Decimal values in MF, all others in MMF unless otherwise specified.  
 VOLTAGES - Measured with a VTVM from point indicated to chassis. ±10% No signal in.  
 \* - CHASSIS, \*\* - RC BASE

VOLUME R-18, MOST-OFTEN-NEEDED 1958 RADIO SERVICING INFORMATION

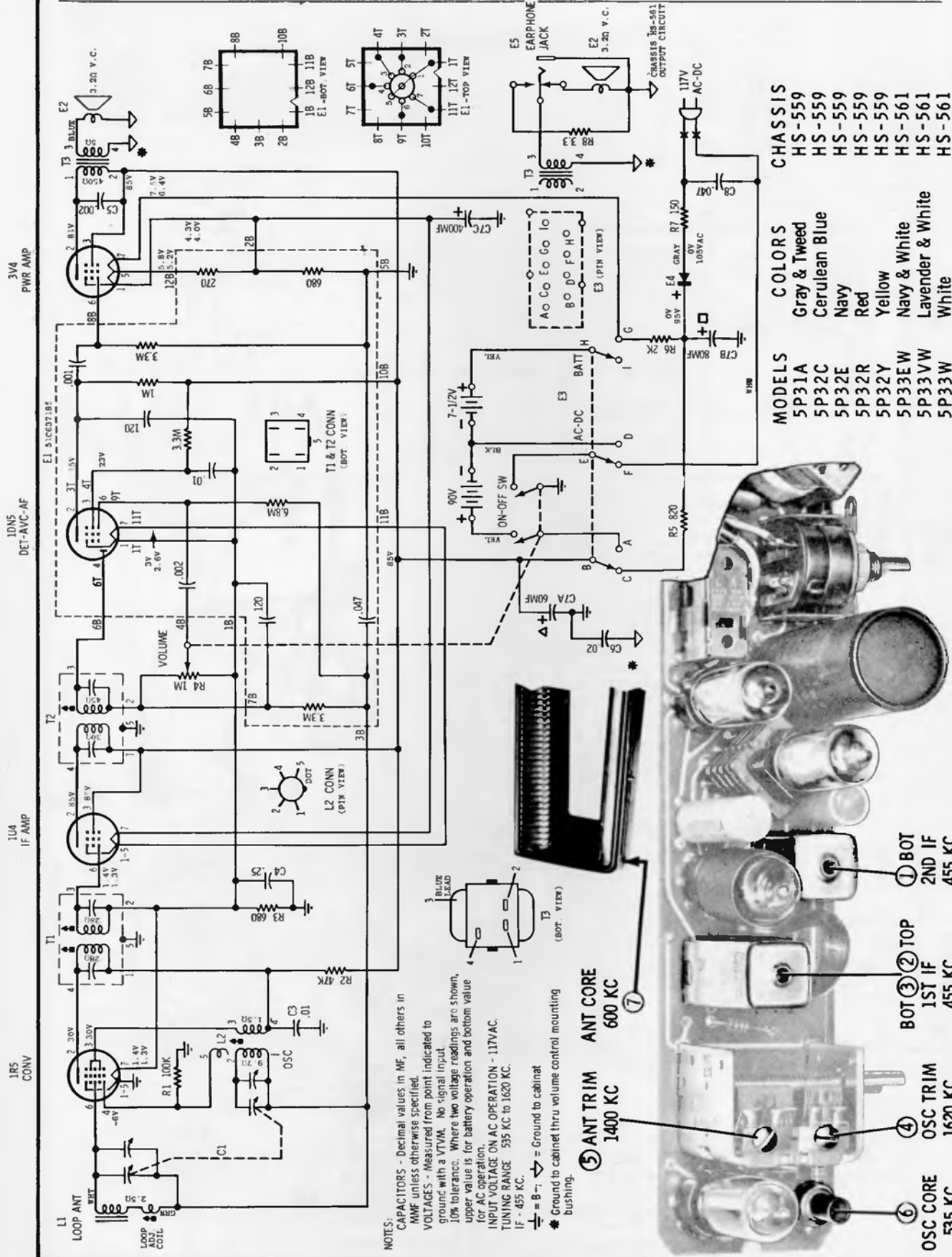

NOTES:  
 CAPACITORS - Decimal values in MF, all others in MMF unless otherwise specified.  
 VOLTAGES - Measured from point indicated to ground with a VTVM. No signal input 10% tolerance. Where two voltage readings are shown, upper value is for battery operation and bottom value for AC operation.  
 INPUT VOLTAGE ON AC OPERATION - 117VAC.  
 TUNING RANGE 535 KC to 1620 KC.  
 IF - 455 KC.  
 ⊕ = B+; ⊖ = Ground to cabinet bushing.  
 \* Ground to cabinet thru volume control mounting bushing.

- ⑤ ANT TRIM 1400 KC
- ⑥ OSC CORE 535 KC
- ⑦ ANT CORE 600 KC
- BOT ③ TOP ② 1ST IF 455 KC
- ④ OSC TRIM 1620 KC
- BOT ① 2ND IF 455 KC

MODELS	COLORS	CHASSIS
5P31A	Gray & Tweed	HS-559
5P32C	Cerulean Blue	HS-559
5P32E	Navy	HS-559
5P32R	Red	HS-559
5P32Y	Yellow	HS-559
5P33EW	Navy & White	HS-561
5P33VW	Lavender & White	HS-561
5P33W	White	HS-561

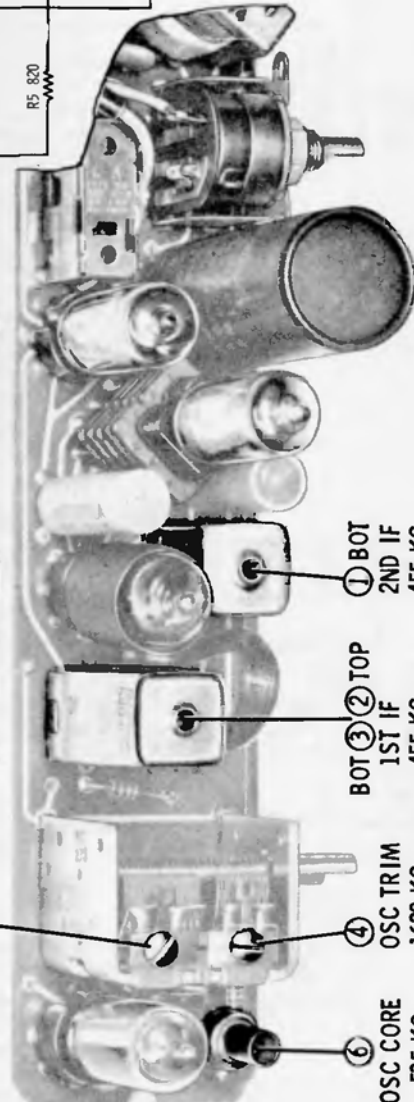

ALIGNMENT LOCATIONS

**MOTOROLA**

VOLUME R-18, MOST-OFTEN-NEEDED 1958 RADIO SERVICING INFORMATION

**MOTOROLA**

MODELS

CHASSIS

5R23G  
5R23G-1  
5R23N  
5R23N-1

HS-600  
HS-643  
HS-600  
HS-643

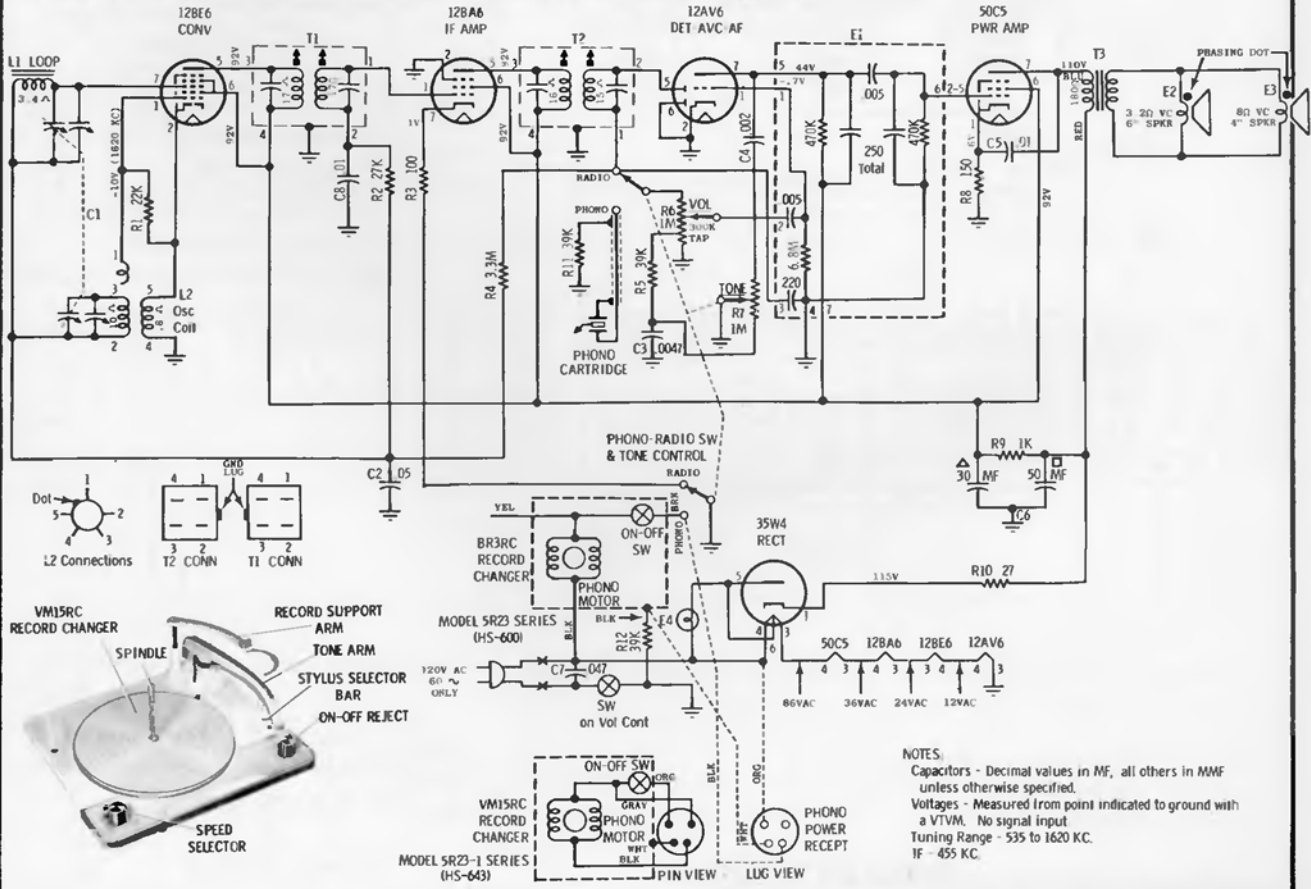
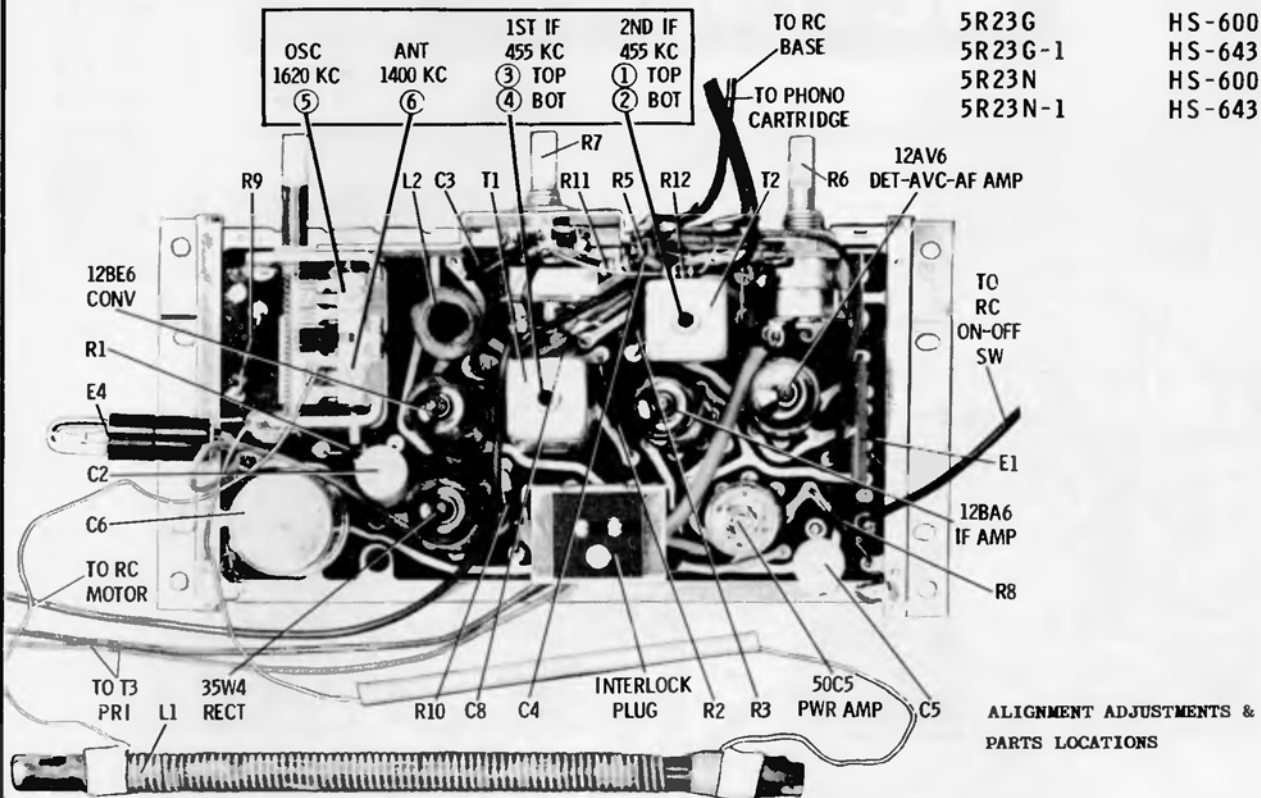

NOTES:  
Capacitors - Decimal values in MF, all others in MMF unless otherwise specified.  
Voltages - Measured from point indicated to ground with a VTVM. No signal input.  
Tuning Range - 535 to 1620 KC.  
IF - 455 KC.

# MOTOROLA

MODELS	CHASSIS
5T21W-1	HS-625
5T22M-1	HS-625
5T22R-1	HS-625
5T22W-1	HS-625
5T22Y-1	HS-627
5T23N-1	HS-627
5T23P-1	HS-627
5T23W-1	HS-627
5T23Y-1	HS-627



5T21-1 SERIES

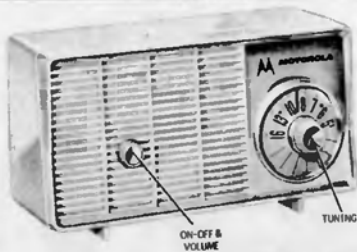

5T23-1 SERIES

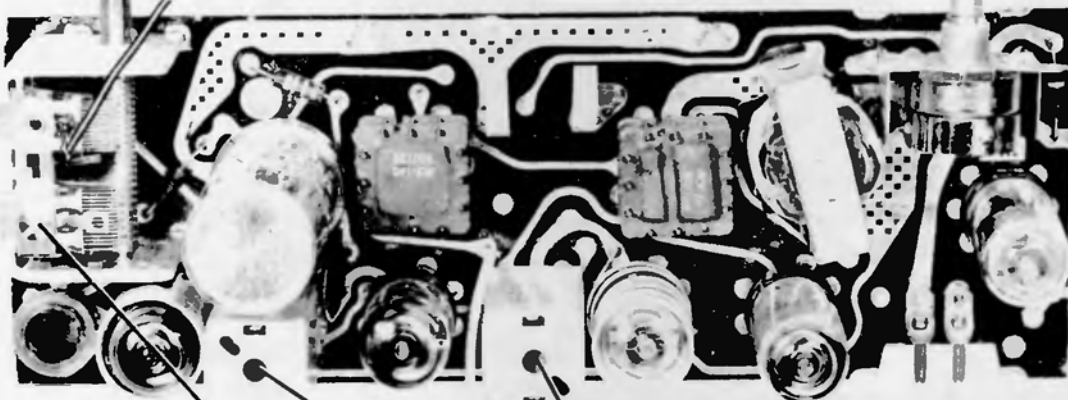

ALIGNMENT LOCATIONS

- ⑤ OSC 1620KC
- ③ TOP 1ST IF 455KC
- ④ BOT
- ① TOP 2ND IF 455KC
- ② BOT
- ⑥ ANT CORE 600KC

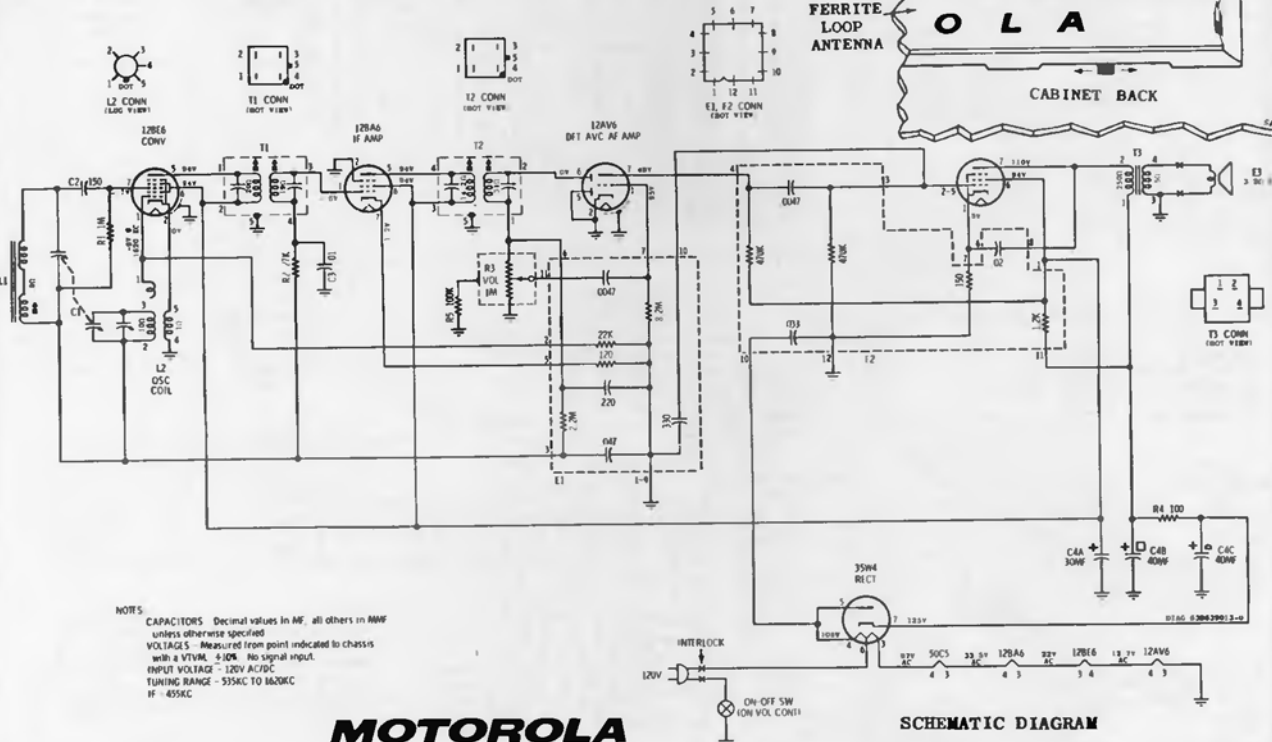
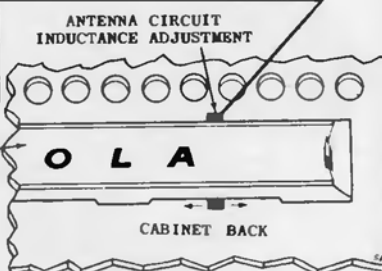

**MOTOROLA**



# MOTOROLA

MODELS	CHASSIS
5T24GW-1	HS-628
5T24WN-1	HS-628
5T25B-1	HS-629
5T25M-1	HS-629
5T25MC-1	HS-629

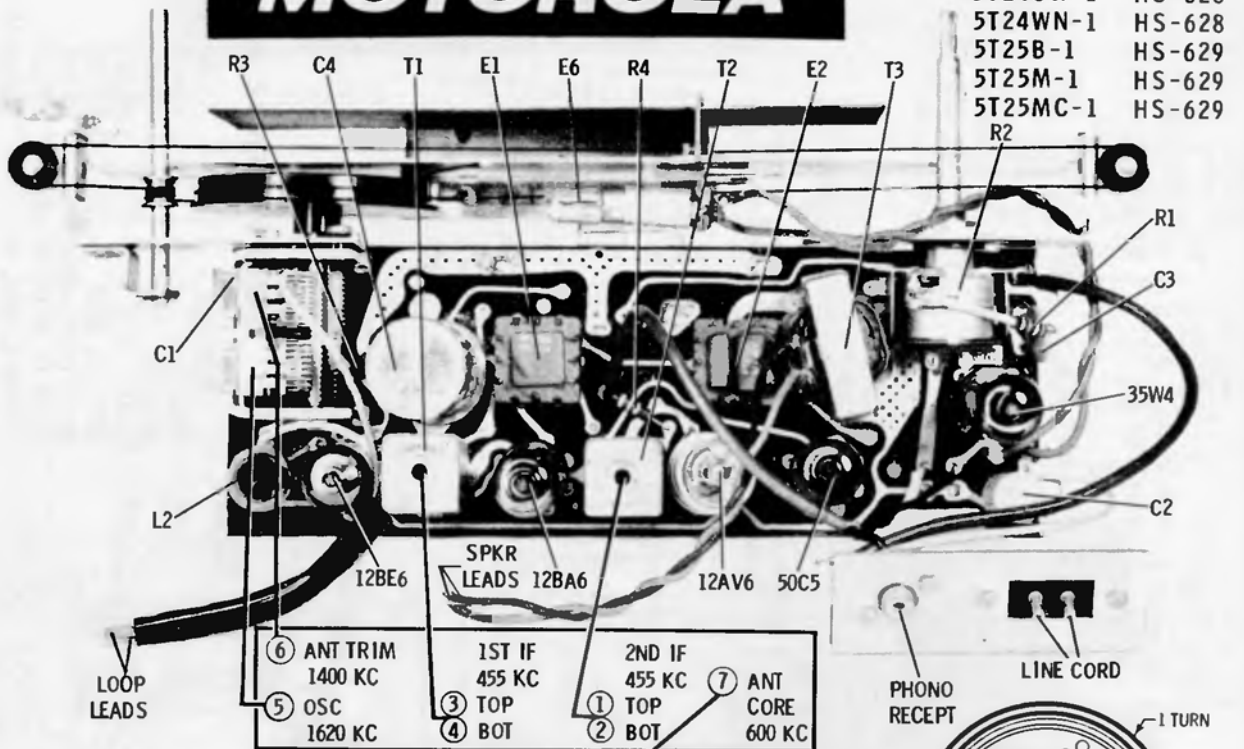

ANTENNA CIRCUIT INDUCTANCE ADJUSTMENT

FERRITE LOOP ANTENNA



MODEL 5T25-1 ALIGNMENT ADJUSTMENTS AND PARTS LOCATIONS

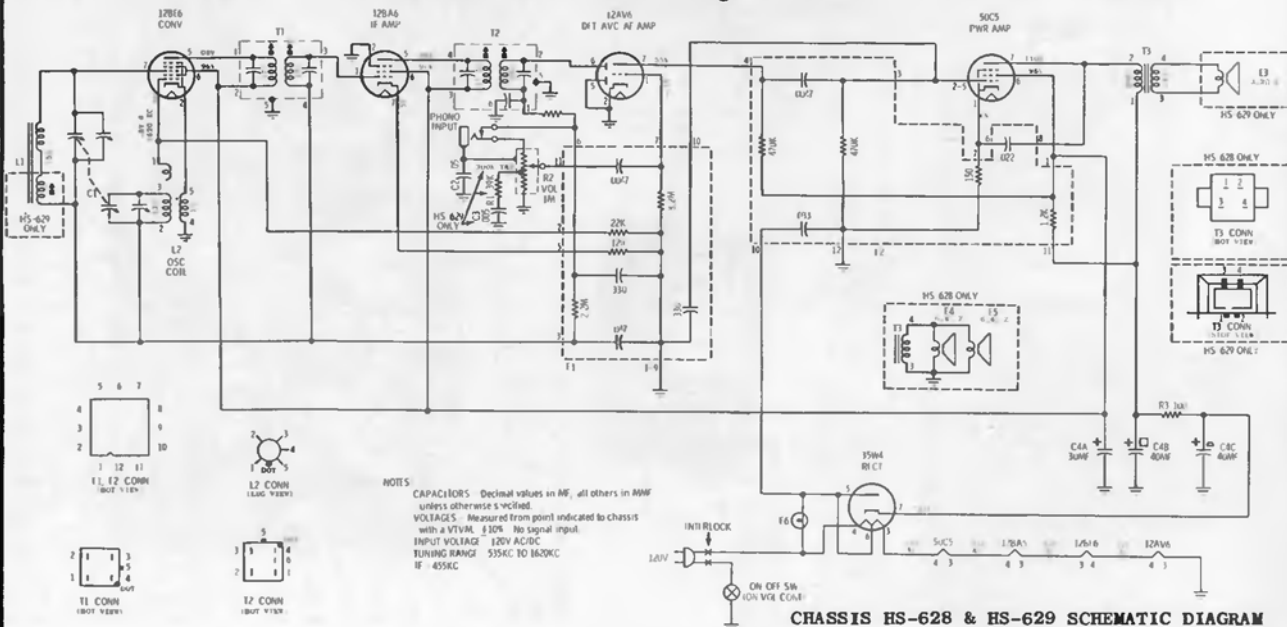
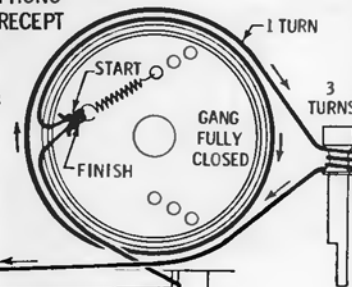
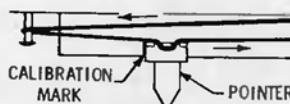

NOTES:  
 CAPACITORS: Decimal values in MF, all others in MMF unless otherwise specified.  
 VOLTAGES: Measured from point indicated to chassis with a VTVM  $\pm 10\%$ . No signal input.  
 INPUT VOLTAGE: 120V AC/DC.  
 TUNING RANGE: 535KC TO 1600KC IF - 455KC.

CHASSIS HS-628 & HS-629 SCHEMATIC DIAGRAM

**MOTOROLA**

**MOTOROLA**

**MODELS**

- 6H265-1
- 6H26S-1A
- 6H27B-1, W-1
- 6H27B-1A, W-1A
- 6K22B-1, M-1, MC-1, W-1
- 6K22B-1A, M-1A, MC-1A, W-1A
- 15KT24B-1, CW-1, M-1
- 15KT24B-1A, CW-1A, M-1A

**CHASSIS**

- HS-619
- HS-621
- HS-619
- HS-621
- HS-619
- HS-621
- HS-619
- HS-621

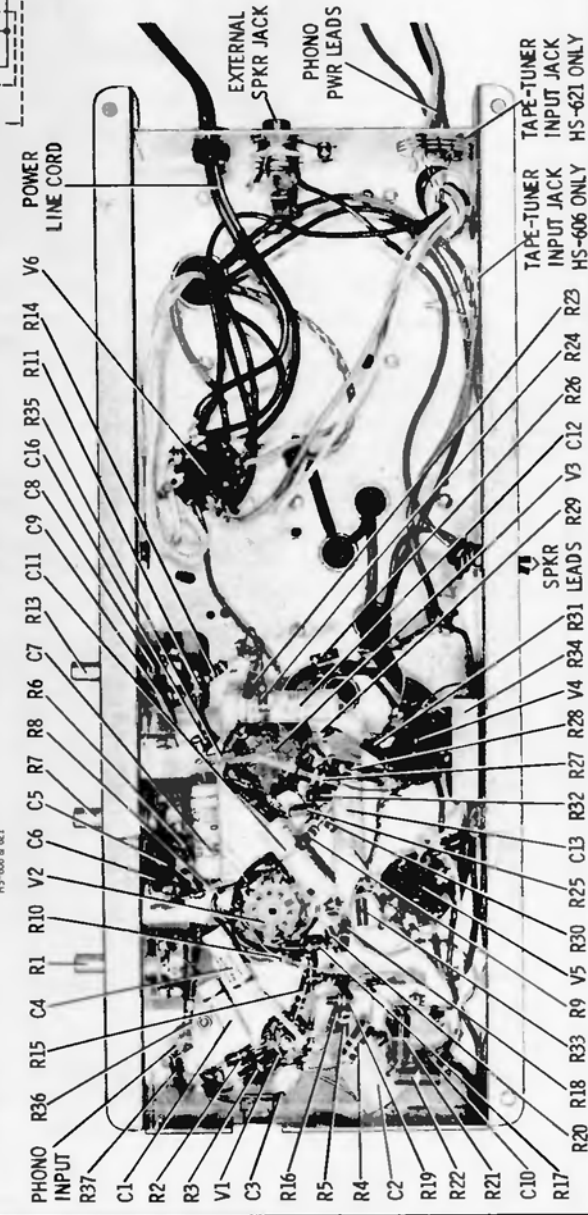
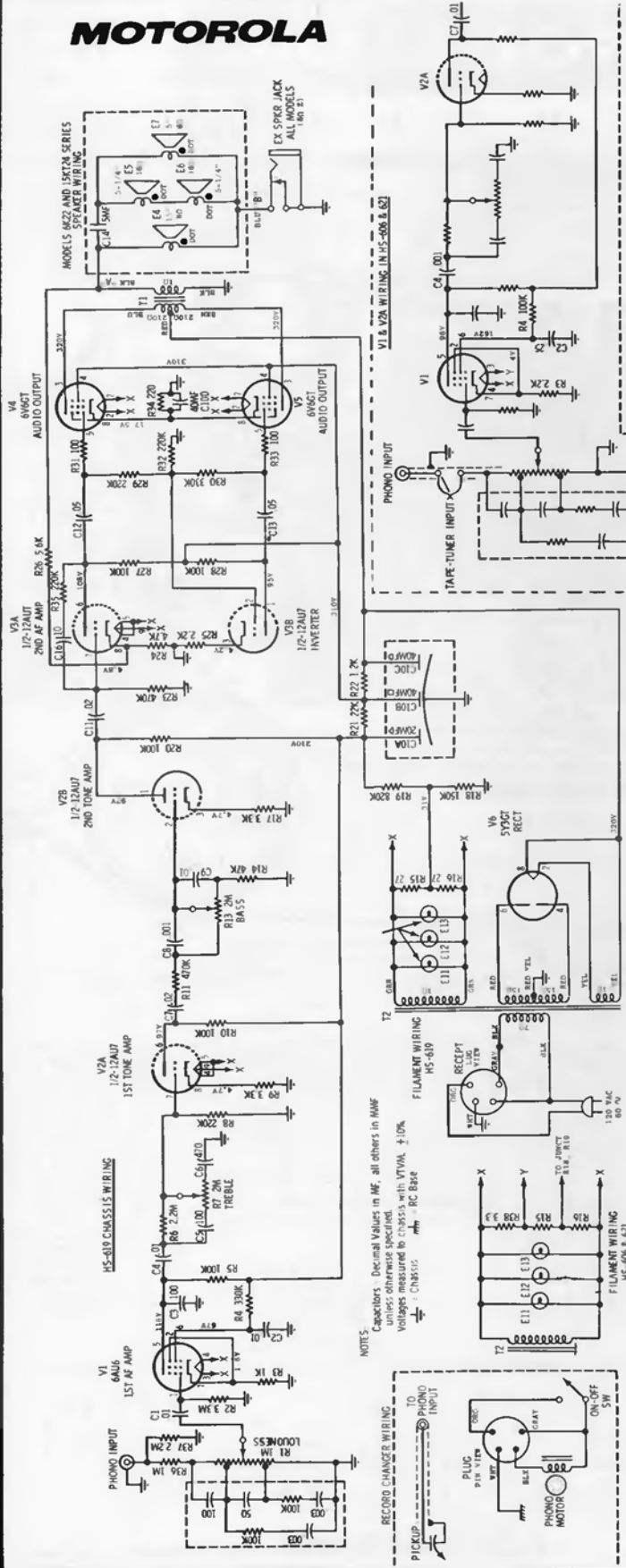

**NOTES:** Decimal Values in  $\mu F$ , all others in MAF unless otherwise specified. Voltages measured to chassis with VTVM,  $\pm 10\%$ . Chassis - RC Base.

**PARTS LOCATION**

# MOTOROLA

CHASSIS  
HS-562

MODELS  
6P34E Navy  
6P34S Sun Tan

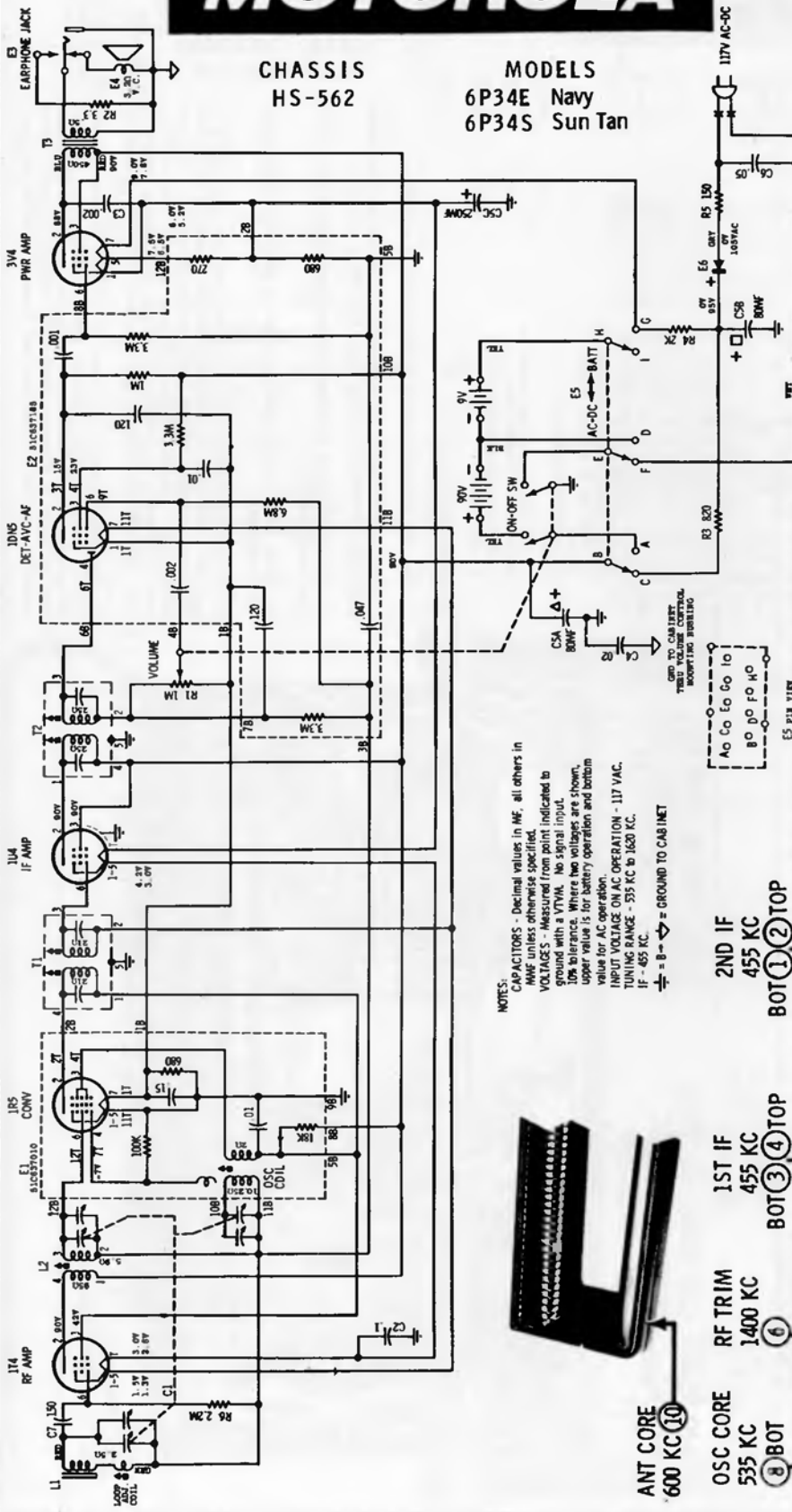

NOTES:  
CAPACITORS - Decimal values in MF, all others in MAF unless otherwise specified.  
VOLTAGES - Measured from point indicated to ground with a VTVM. No signal input.  
10% tolerance. Where two voltages are shown, upper value is for battery operation and bottom value for AC operation.  
INPUT VOLTAGE ON AC OPERATION - 117 VAC.  
TUNING RANGE - 535 KC to 1620 KC.  
⊕ - B → = GROUND TO CABINET

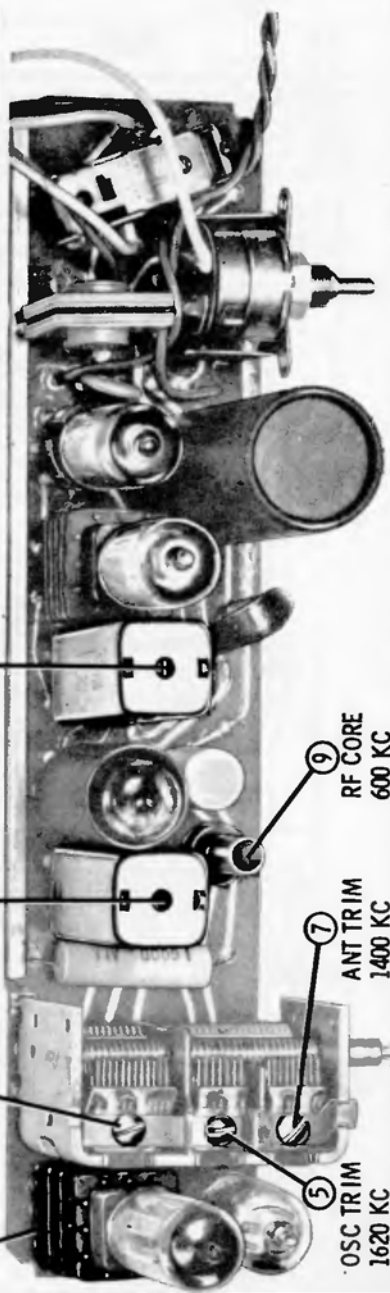
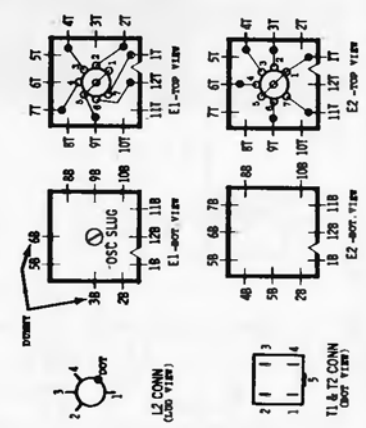

- ANT CORE 600 KC (10)
- OSC CORE 535 KC (8) BOT
- RF TRIM 1400 KC (6)
- 1ST IF 455 KC (3) BOT (4) TOP
- 2ND IF 455 KC (1) (2) TOP
- OSC TRIM 1620 KC (5)
- ANT TRIM 1400 KC (7)
- RF CORE 600 KC (9)

# MOTOROLA

MODELS	CHASSIS
6X31C	Blue & Beige HS-564
6X31N	Beige HS-564
6X31R	Red & Beige HS-564
6X32E	Navy Blue HS-563

V5\*  
2N1186 OR 2N1187 (HS-564)  
2N1188 OR 2N1241 (HS-563)  
PNR AMP

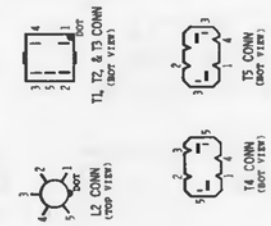
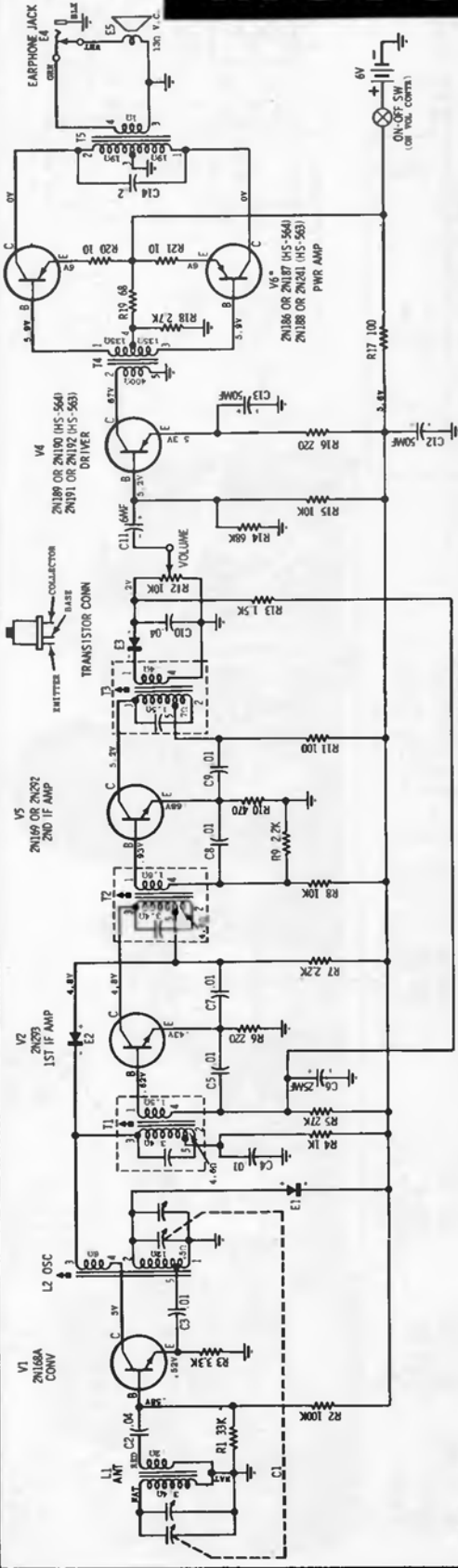

NOTES:  
CAPACITORS - Decimal values in MF, others in MUF unless otherwise specified.  
VOLTAGES - Measured from point indicated to ground with a VTVM  $\pm 10\%$ . No signal input, volume at maximum.  
TUNING RANGE - 530 KC to 1620 KC.  
\*Do not intermix power amplifier types, use two of the same type transistors in the output stage.  
DISTANCES - Measured with the transistors out of associated circuits.

### CHASSIS REMOVAL

1. Pull the volume control knob from front of radio.
2. Remove tuning knob retaining screw from the tuning knob and remove the tuning knob (see cover photo).
3. Remove chassis mounting screw from under tuning knob (see cover photo).
4. Open rear cover and turn handle perpendicular to the plated chassis.
5. Grasp handle near one of its two mounting bushings and pull out from side of cabinet until the round portion of the mounting bushing clears hole in side of cabinet, then lift this side of handle and chassis slightly out of cabinet. Perform the same procedure on the other mounting bushing, then lift handle, chassis and speaker plate out of cabinet.
6. The plated chassis is separated from the speaker mounting plate as follows: unsolder the wire that connects from the gang to the plated chassis. Remove speaker, earphone jack, antenna & battery leads from plated chassis. Then unsolder one at a time the four chassis mounting support lugs.

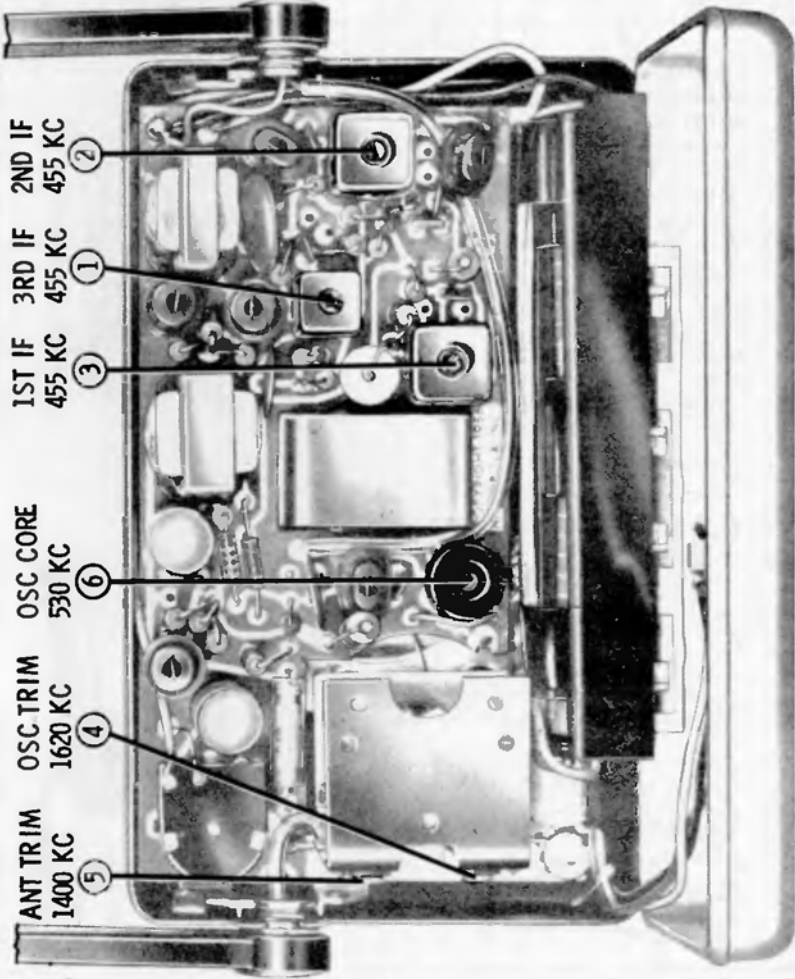

ALIGNMENT LOCATIONS

# MOTOROLA

MODEL	CHASSIS
6X39A	HS-630
6X39A-1	HS-683
6X39A-2	HS-684

### CHASSIS REMOVAL

1. Pull the volume control knob from front of radio.
2. Remove tuning knob retaining screw from the tuning knob and remove the tuning knob.
3. Remove chassis mounting screw from under tuning knob.
4. Open rear cover and turn handle perpendicular to the plated chassis.
5. Grasp handle near one of its two mounting bushings and pull out from side of cabinet until the round portion of the mounting bushing clears hole in side of cabinet, then lift this side of handle and chassis slightly out of cabinet. Perform the same procedure on the other mounting bushing, then lift handle, chassis and speaker plate out of cabinet.
6. The plated chassis is separated from the speaker mounting plate as follows: unsolder the wire that connects from the gang to the plated chassis. Remove speaker, earphone jack, antenna & battery leads from plated chassis. Then unsolder one at a time the three chassis mounting support lugs.

### HANDLE REPLACEMENT

1. Remove chassis and speaker mounting plate from cabinet as described under CHASSIS REMOVAL.
2. Unsolder antenna leads from chassis.
3. Turn handle perpendicular to chassis and slide out of handle clips.

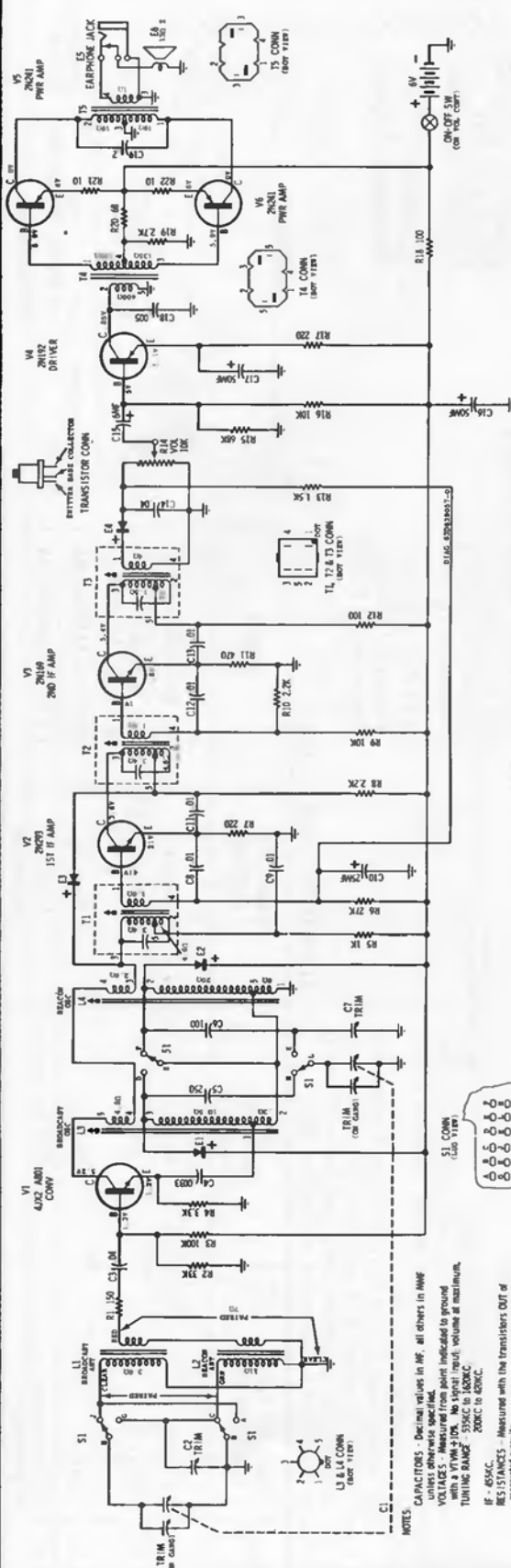
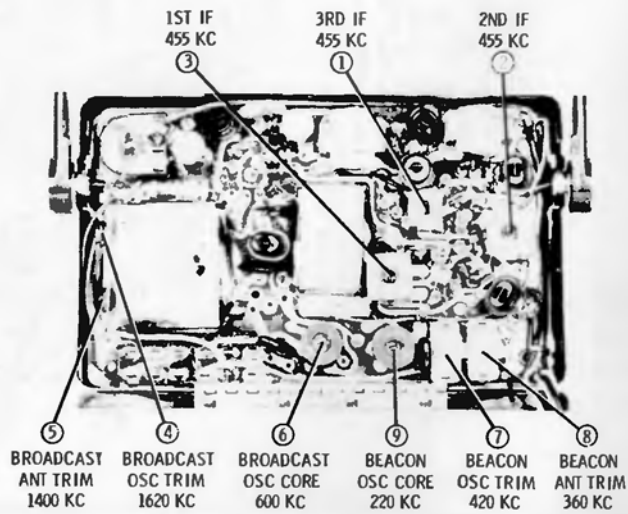
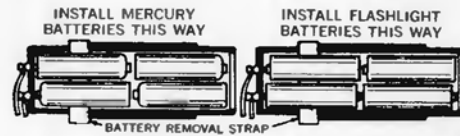

NOTES:  
 CAPACITORS - Decimal values in  $\mu$ F, all others in M $\mu$ F unless otherwise specified.  
 VOLTAGES - Measured from point indicated to ground.  
 TUNING RANGE - 530 KC to 1700 KC.  
 IF - 455 KC.  
 RESISTANCES - Measured with the transistors OUT of associated circuits.  
 S1 - 4-POS SWITCH - Shown in Broadcast band position.

# Packard Bell

## TABLE MODEL RADIO 6R1 CLOCK RADIO MODEL 6RC1

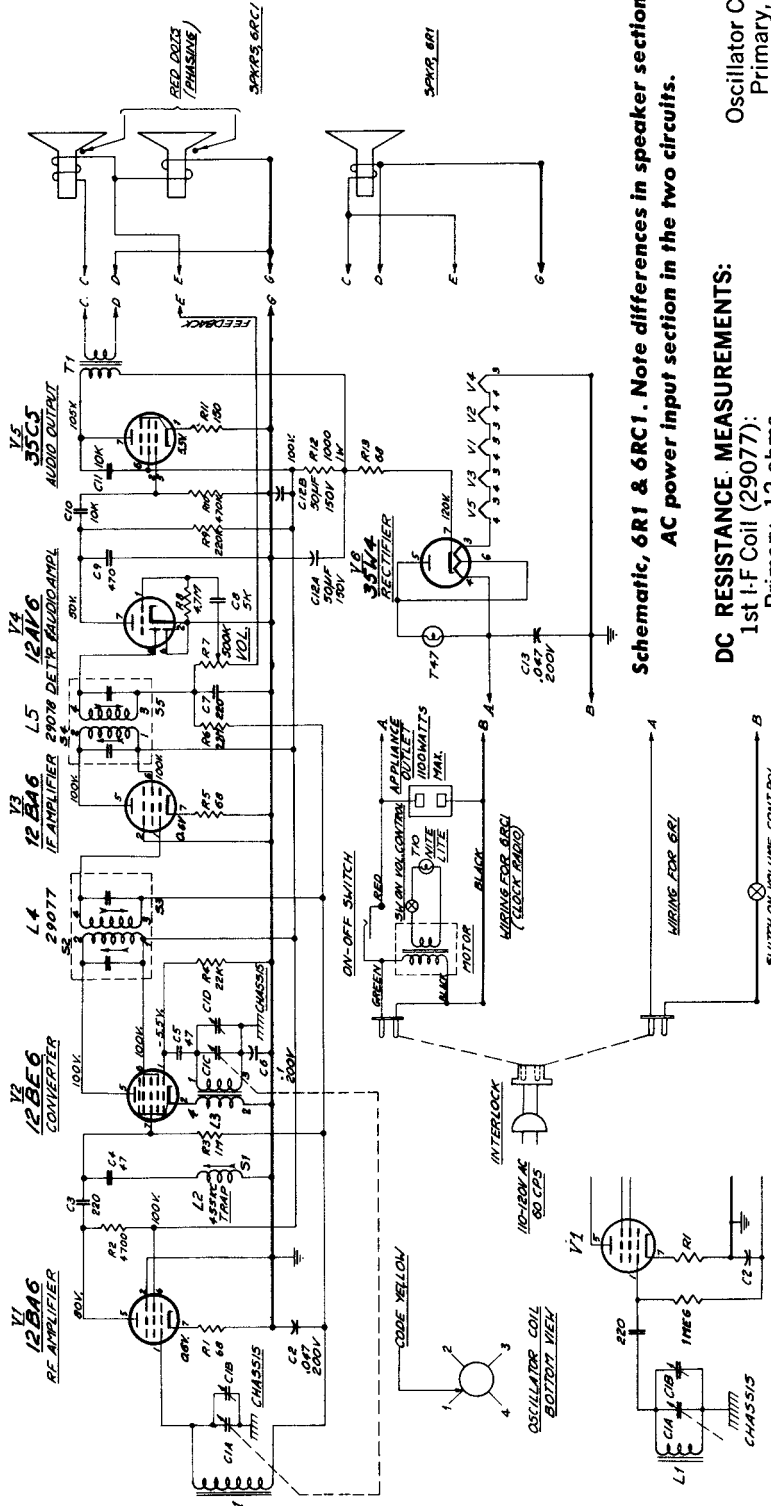

**Schematic, 6R1 & 6RC1. Note differences in speaker section and AC power input section in the two circuits.**

**DC RESISTANCE MEASUREMENTS:**

- 1st I-F Coil (29077):**  
 Primary, 12 ohms  
 Secondary, 13 ohms
- 2nd I-F Coil (29078):**  
 Primary, 13 ohms  
 Secondary, 13 ohms

- Oscillator Coil (29229B)**  
 Primary, 1 ohm  
 Secondary, 5.5 ohms
- Loop antenna:**  
 Resistance, 0.3 ohms

The alignment of the set is accomplished by following the steps in the chart below. Connect output meter to speaker voice coil.

Each adjustment should be made using a minimum input signal. Connect test oscillator through a .01 mfd capacitor to the point indicated below. Ground lead of oscillator is connected to B minus bus.

**ALIGNMENT PROCEDURE:**

Step	Connect Test Oscillator to	Test Oscillator Frequency	Radio Dial Setting	Adjust
1.	Pin 1, V-1 (12BA6)	455 kc	540 kc	S-1 for minimum
2.	ditto	ditto	ditto	S-2, S-3, S-4, & S-5 for MAXIMUM
3.	ditto	1620 kc	Tune to	C1-D for MAXIMUM
4.	Loose-couple to antenna	1500 kc	1620 kc oscillator	C1-B for MAXIMUM

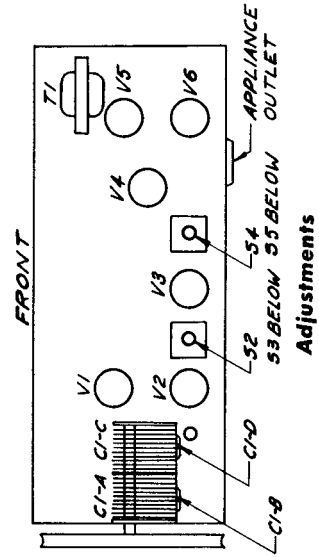

# PHILCO TRANSISTOR RADIO

## MODEL T-500 — CODE 124

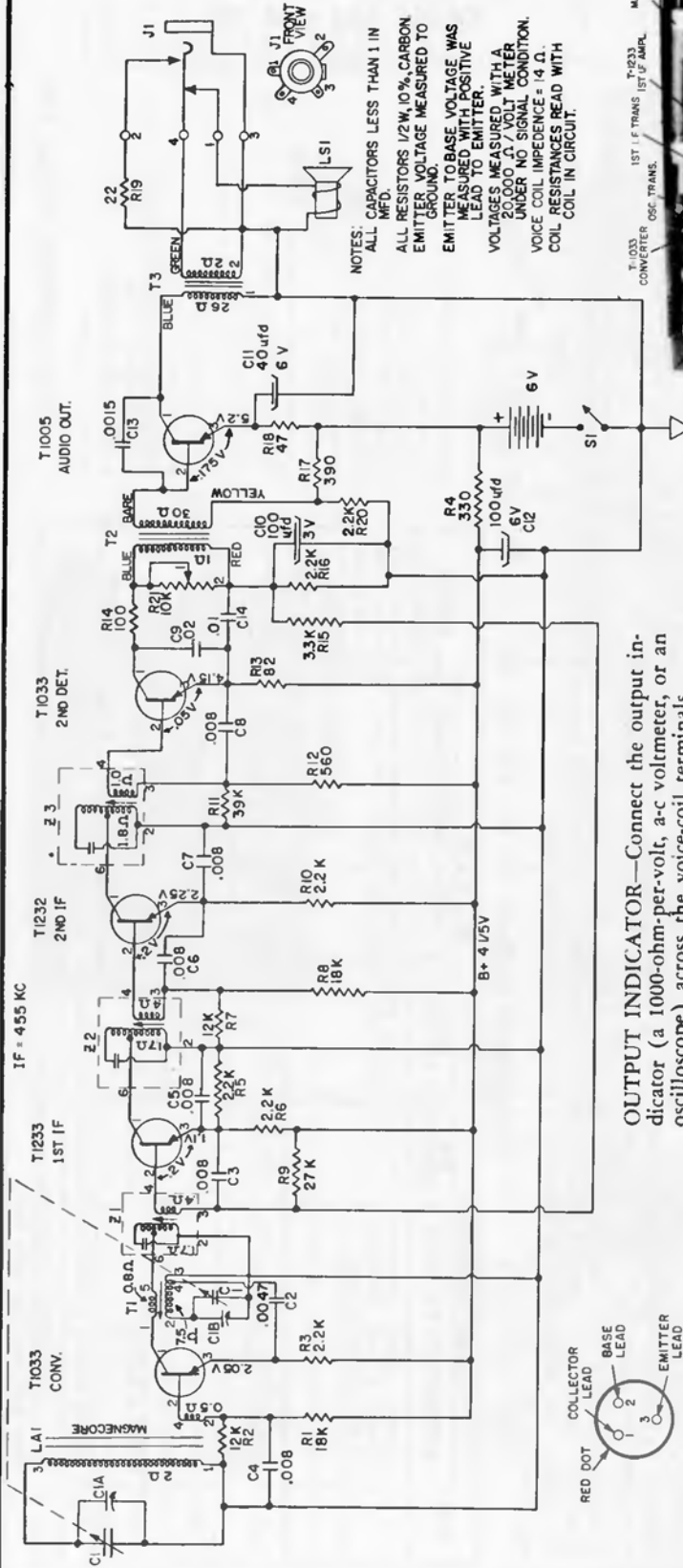

**OUTPUT INDICATOR**—Connect the output indicator (a 1000-ohm-per-volt, a-c voltmeter, or an oscilloscope) across the voice-coil terminals.

### ALIGNMENT CHART

STEP	RADIO			ADJUST
	SIGNAL GENERATOR CONNECTION TO RADIO	DIAL SETTING	SPECIAL INSTRUCTIONS	
1	Panel must be removed from cabinet. Connect signal generator through a .1 uf condenser to antenna section of gang. Use the least generator signal necessary to give an output indication.	455 KC	Tuning gang fully open. Adjust for maximum output in order given.	Z3—3rd IF Z2—2nd IF Z1—1st IF
2	Use radiating loop (See note 1 below).	1620 KC	1620 KC (gang fully open)	C1B—osc. trimmer
3	Same as step 2.	1400 KC	1400 KC	C1A—ant. trimmer
4	Same as step 2. Panel MUST be re-mounted in cabinet.	600 KC	600 KC	T1—osc. core
5	Repeat steps 2, 3 and 4 until no further improvement is obtained. Always stop on step 2.			

**NOTE 1.** Use a 6-to-8 turn, 6-inch diameter loop made up of insulated wire. Connect to generator terminals, and place about one foot from radio loop.

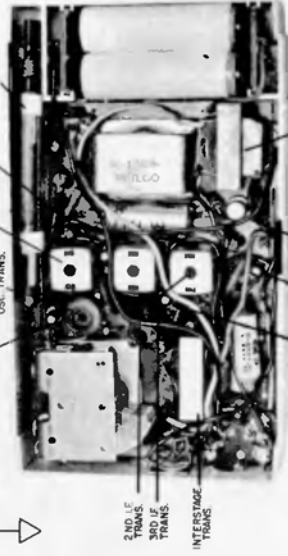

### TERMINAL LUG IDENTIFICATION

- L1 Orange jumper to L4, 5 volt B+.
- L2 Yellow lead to T2.
- L3 To short antenna lead no. 4.
- L4 Orange jumper to L1, 4.5 volt B+.
- L5 Black jumper to ground lug L10.
- L6 Black lead to positive battery terminal (6 volts).
- L7 Green lead to arm of R21.
- L8 Orange lead to end (No. 2) of R21.
- L9 Blue lead of T3.

# PHILCO TRANSISTOR RADIOS

MODELS T-700 and T-800  
CODES 124 and 126

(Continued on page 121, at right)

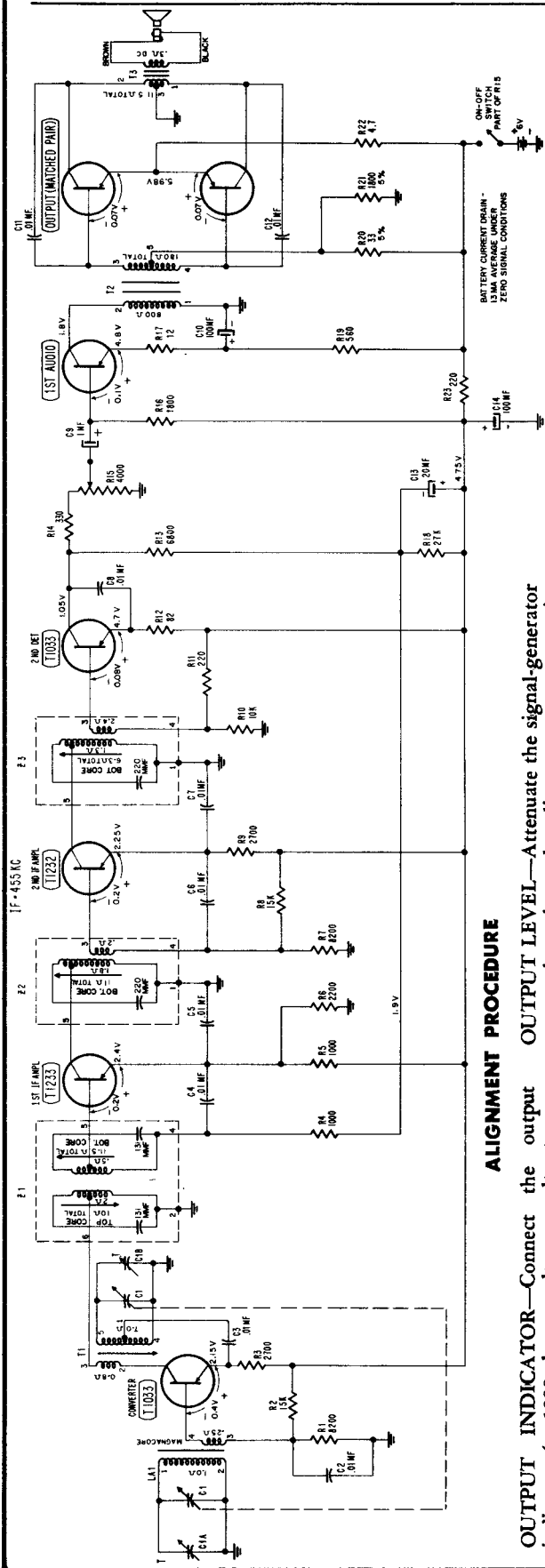

### ALIGNMENT PROCEDURE

**OUTPUT INDICATOR**—Connect the output indicator (a 1000-ohm-per-ohm, a-c voltmeter, or an oscilloscope) across the voice-coil terminals.

**SIGNAL GENERATOR**—Use an AM r-f signal generator. Connect the ground lead to chassis, and connect the output lead as indicated in the alignment chart.

**OUTPUT LEVEL**—Attenuate the signal-generator output throughout the alignment so as to maintain the output level below .4 volt.

**RADIO CONTROLS**—Set the volume control to maximum. Set the tuning control as indicated in the alignment chart.

### ALIGNMENT CHART

STEP	R A D I O			ADJUST
	SIGNAL GENERATOR CONNECTION TO RADIO	DIAL SETTING	SPECIAL INSTRUCTIONS	
1	Connect signal generator through a .1-uf. condenser to ant. section of gang.	455 kc.	Tuning gang fully open.	Z3—3rd i-f pri. Z2—2nd i-f pri. Z1—1st i-f sec. (Bottom Core) Z1—1st i-f pri. (Top Core)
2	Use radiating loop. (See NOTE 1 below).	600 kc.	600 kc.	T1—osc. core Rock tuning gang while making this adjustment.
3	Same as step 2.	1620 kc.	1620 kc. (Tuning gang fully open)	C1B—osc. trimmer
4	Same as step 2.	1400 kc.	1400 kc.	C1A—antenna trimmer
5	Repeat steps 2, 3 and 4 until no further improvement is obtained. Always stop on step 4.			

NOTE 1. Use a 6-to-8-turn, 6-inch diameter loop made up of insulated wire. Connect to generator terminals, and place about one foot from radio loop.

\* VOLTAGES READ UNDER NO SIGNAL CONDITIONS WITH A 20,000 PER VOLT METER. COIL RESISTANCES READ WITH COIL CONNECTED IN THE CIRCUIT.

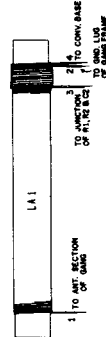
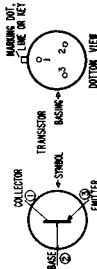

MODEL	CODE	TRANSISTORS	OUTPUT
T-700	124	T 1000	T 1007
T-800	126	T 1000	T 1007
T-800	126	T 1000	T 1008



PHILCO Models T-700 and T-800

(Continued from page 120)

REPLACEMENT PARTS LIST

T1	Transformer, oscillator	32-4689-2
T2	Transformer, audio driver	32-8813
T3	Transformer, audio output	32-8812
T1033	Transistor, converter and 2nd detector, 2 used	34-6000-3
T1233	Transistor, 1st I-F amplifier	34-6000-12
T1232	Transistor, 2nd I-F amplifier	34-6000-11
	Transistor, 1st audio, code 124, T1001	34-6001-16
	Transistor, 1st audio, code 126, T1000	34-6001-15
	Transistors, output, matched pair, code 124, T1007	34-6008
	Transistors, output, matched pair, code 126, T1008	34-6008
Z1	Transformer, 1st I-F	32-4736-1
Z2	Transformer, 2nd I-F	32-4736-2
Z3	Transformer, 3rd I-F	32-4736-3
	Printed wiring panel	54-6487
	Battery bracket and spring contactassy., end of panel	76-10141
	Battery bracket and contactassy., center	76-10142

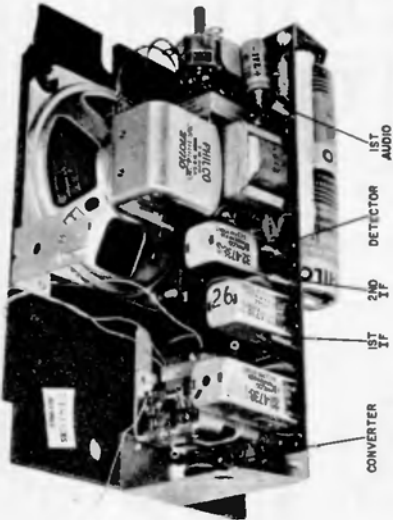

SERVICE NOTES

When signal tracing, inject signal at transistor collector and limit input to keep signal across speaker below 0.4 volts.

Normally, the transistors should be the last item suspected.

The dress (position) of condenser C8 may be helpful in reducing harmonic whistle when encountered. C8 may be bent over toward R14 and the detector transistor. In sets where C8 is in this bent position, do not disturb.

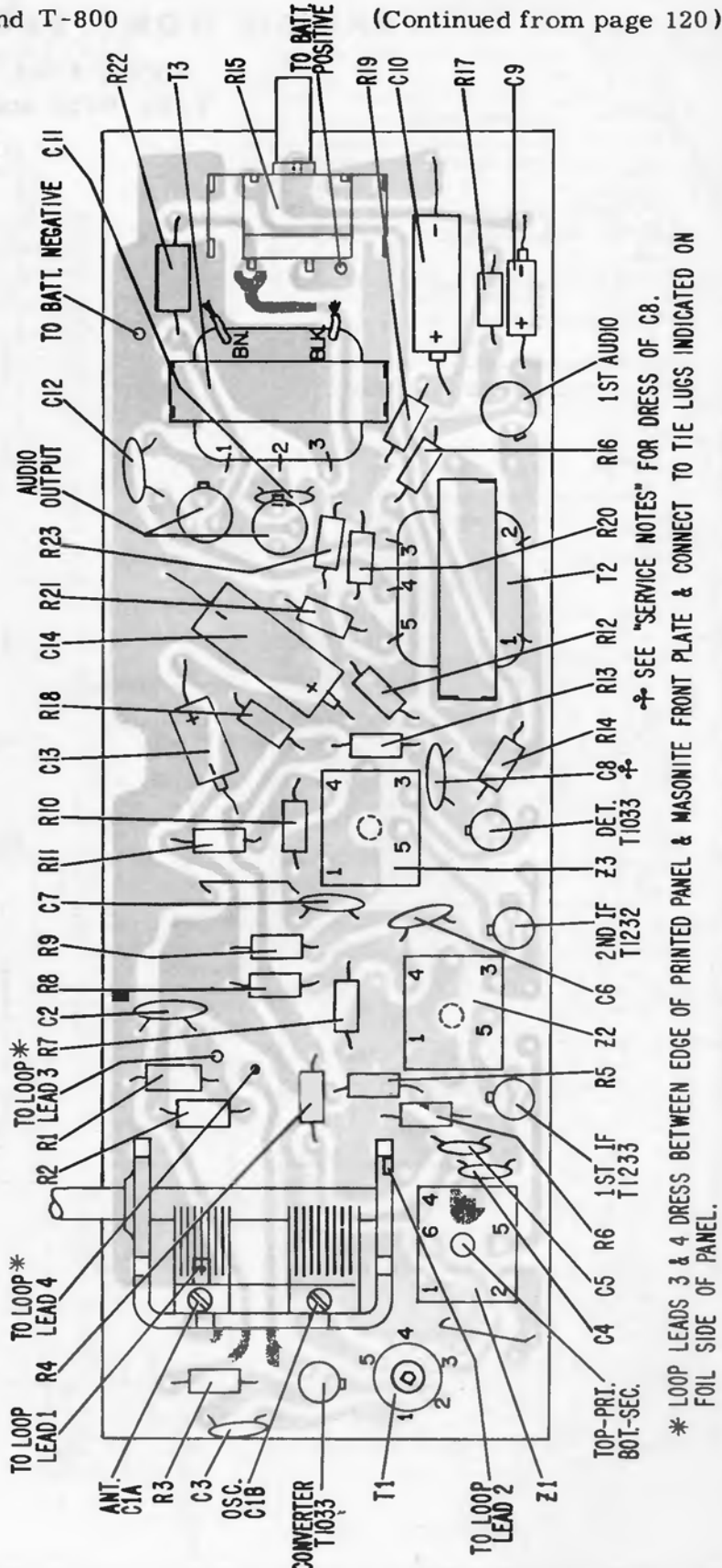

\* SEE "SERVICE NOTES" FOR DRESS OF C8.

\* LOOP LEADS 3 & 4 DRESS BETWEEN EDGE OF PRINTED PANEL & MASONITE FRONT PLATE & CONNECT TO TIE LUGS INDICATED ON FOIL SIDE OF PANEL.

Composite Panel View — Showing Parts Replacement and Tuning Adjustments

# PHILCO HOME RADIO

MODELS F-743, F-750,  
F-752, F-754 and F-758

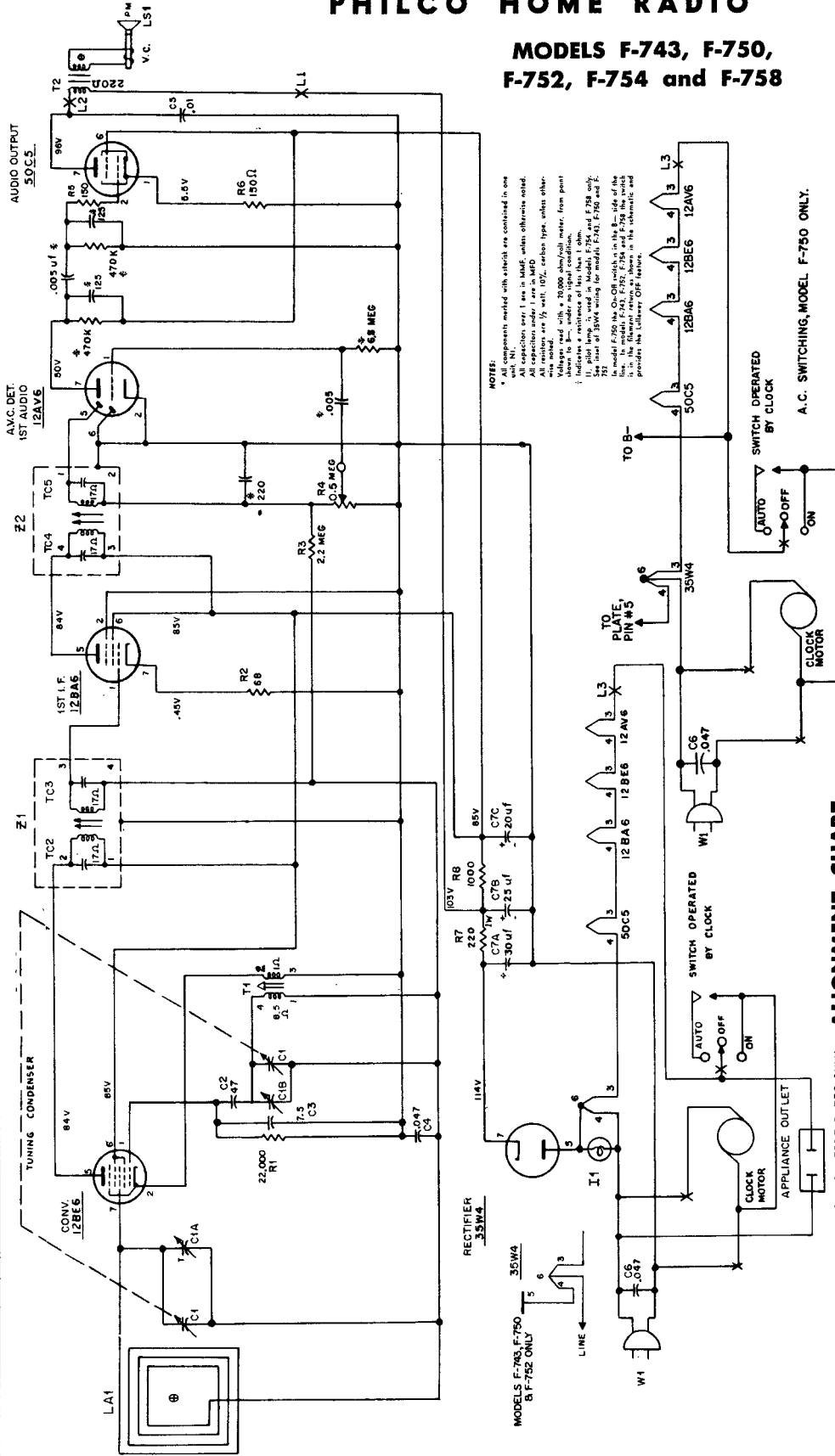

**NOTES:**  
 \* All components marked with asterisk are contained in one kit.  
 All resistors over 1 ohm in value, unless otherwise noted.  
 All capacitors under 1 are in MFD, unless otherwise noted.  
 All resistors are 1/2 watt, 10% carbon type, unless other.  
 Voltages read with a 20,000 ohm/volt meter, from point shown to B—, under no signal conditions.  
 1. R101 lamp: 3 used in models F-754 and F-758 only.  
 In model F-750 the On-Off switch in the B— side of the line. In models F-743, F-752, F-754 and F-758 the switch provides the Lullaby Off feature.  
 2. R101 lamp: 3 used in models F-754 and F-758 only.  
 In model F-750 the On-Off switch in the B— side of the line. In models F-743, F-752, F-754 and F-758 the switch provides the Lullaby Off feature.

## CHASSIS REMOVAL

- (1) Remove Back: In models F-750, F-752, F-754 and F-758 there are two screws holding the back to the cabinet. In model F-743 spring the cabinet top to allow the back top to come back and out. Then lift (or slide upwards) the back to free back from bottom slots. Disengage interlock.
- (2) Remove the drive screw which holds the volume control frame to a boss on inside of cabinet.
- (3) It may be desirable or necessary to unsolder the speaker and clock leads.

## ALIGNMENT CHART

STEP	SIGNAL GENERATOR		RADIO		ADJUST
	CONNECTION TO RADIO	DIAL SETTING	DIAL SETTING	SPECIAL INSTRUCTIONS	
1.	Ground lead to B—; output lead through a .1 mf condenser to grid (pin 7) of 12BE6 or top of i-f tuning condenser.	455 kc.	Tuning gang fully open.	Adjust tuning cores, in order given, for maximum output. TC3 and TC5 are located on top of transformers.	TC5—2nd i-f sec. TC4—2nd i-f pri. TC3—1st i-f sec. TC2—1st i-f pri.
2.	Radiating loop (See Note below).	1620 kc.	1620 kc.	Adjust for maximum output.	Cl-B—osc.
3.	Same as step 2.	1500 kc.	1500 kc.	Adjust for maximum output.	Cl-A—aerial

**NOTE:** Make up a 6-8 turn, 6 inch diameter loop from insulated wire, connect to signal-generator leads, and place near radio loop.

# PHILCO

## MODELS F-760 and F-963

### SPECIFICATIONS

Cabinet: Plastic, table model; Model F-963 has a rotary dial scale with a 5:1 drive ratio. Model F-760 has a slide rule dial with a 6:1 drive ratio.  
 Frequency Coverage: 535KC to 1620KC.  
 Intermediate Frequency: 455 KC.  
 Audio Output: 0.9 watts.  
 Operating Voltage: Model F-963—105 to 120 volts, AC-DC; Model F-760—105 to 120 volts, AC.  
 Aerial: High impedance loop mounted on back.  
 Speakers: (2) 4" pm speakers, each with 3.2 ohm voice coil.  
 Philco Tubes: 12BA6 RF Amplifier, 12BE6 Oscillator-Converter, 12BA6 IF Amplifier, 12AV6 Detector—AVC-1st Audio, 35C5 Audio Output, 35W4 Rectifier and a type 47 Dial Light.  
 Timer: F-760 only—A fully automatic Telechron (type C-103) internal timer and clock. Includes Sleep-Switch, Buzzer Alarm, and "Lullaway" Slow Shut-off.

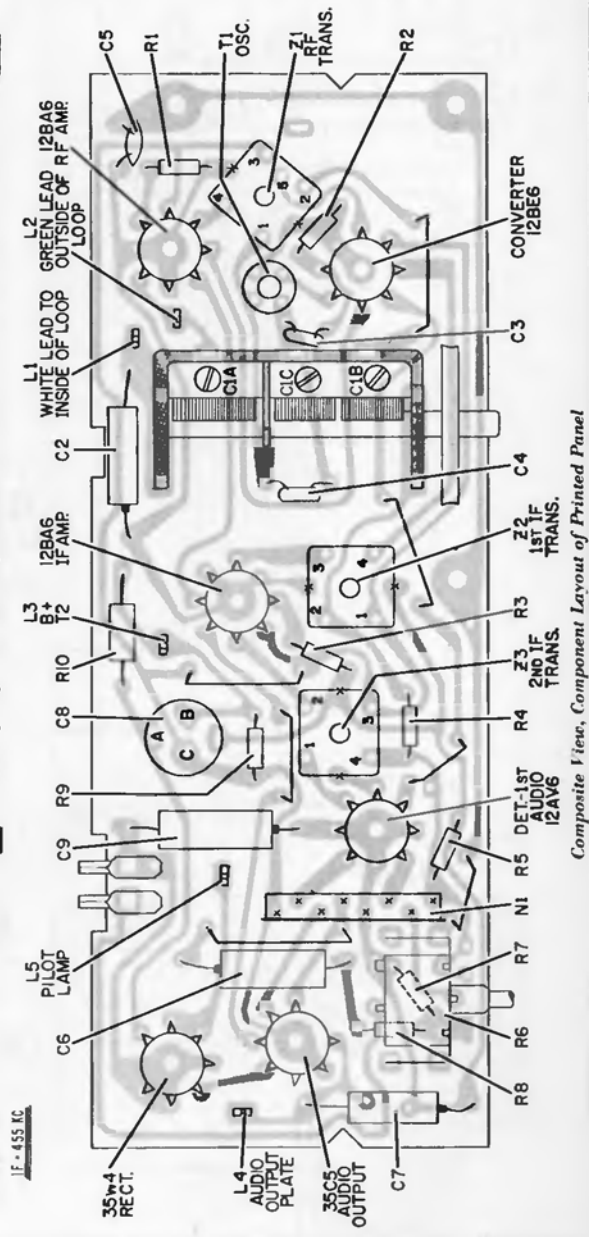
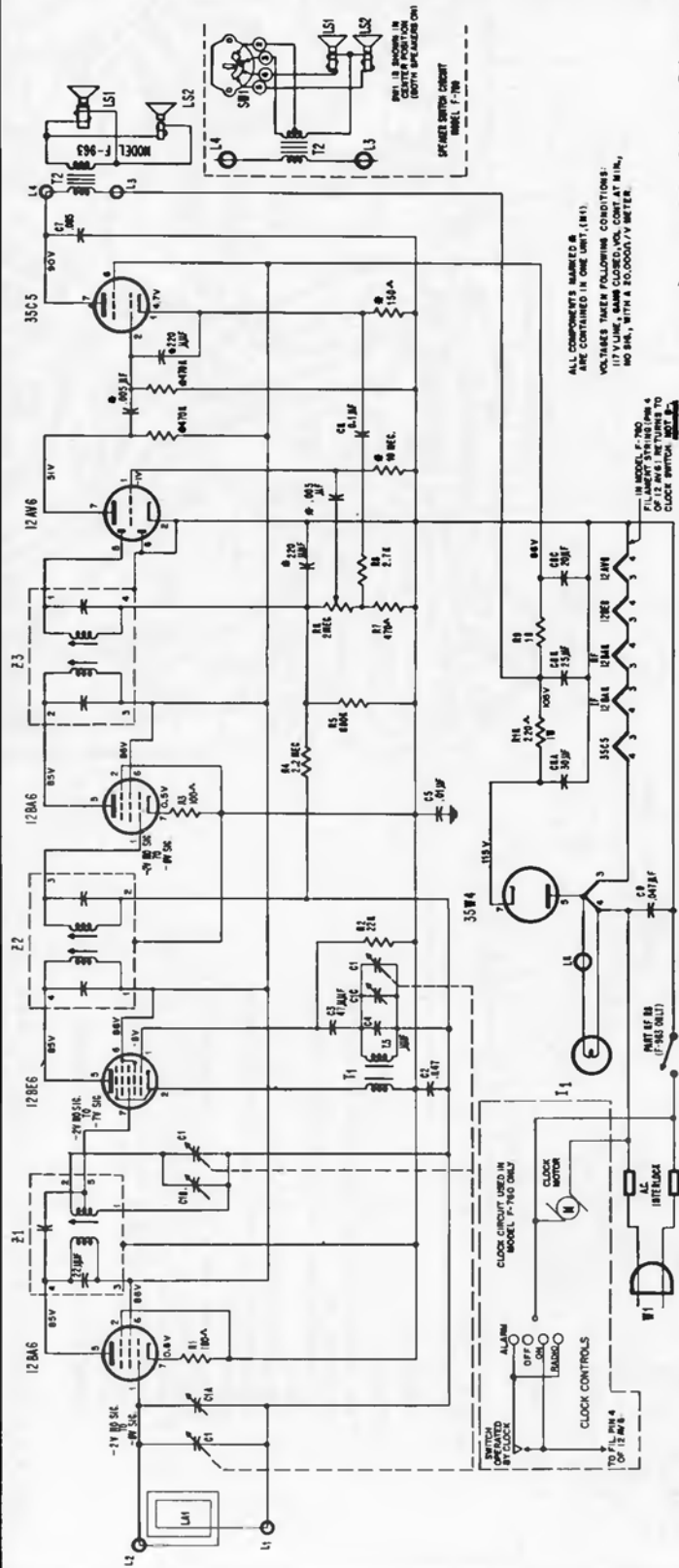

**PHILCO MODELS F-809, F-813  
F-815 and F-817**

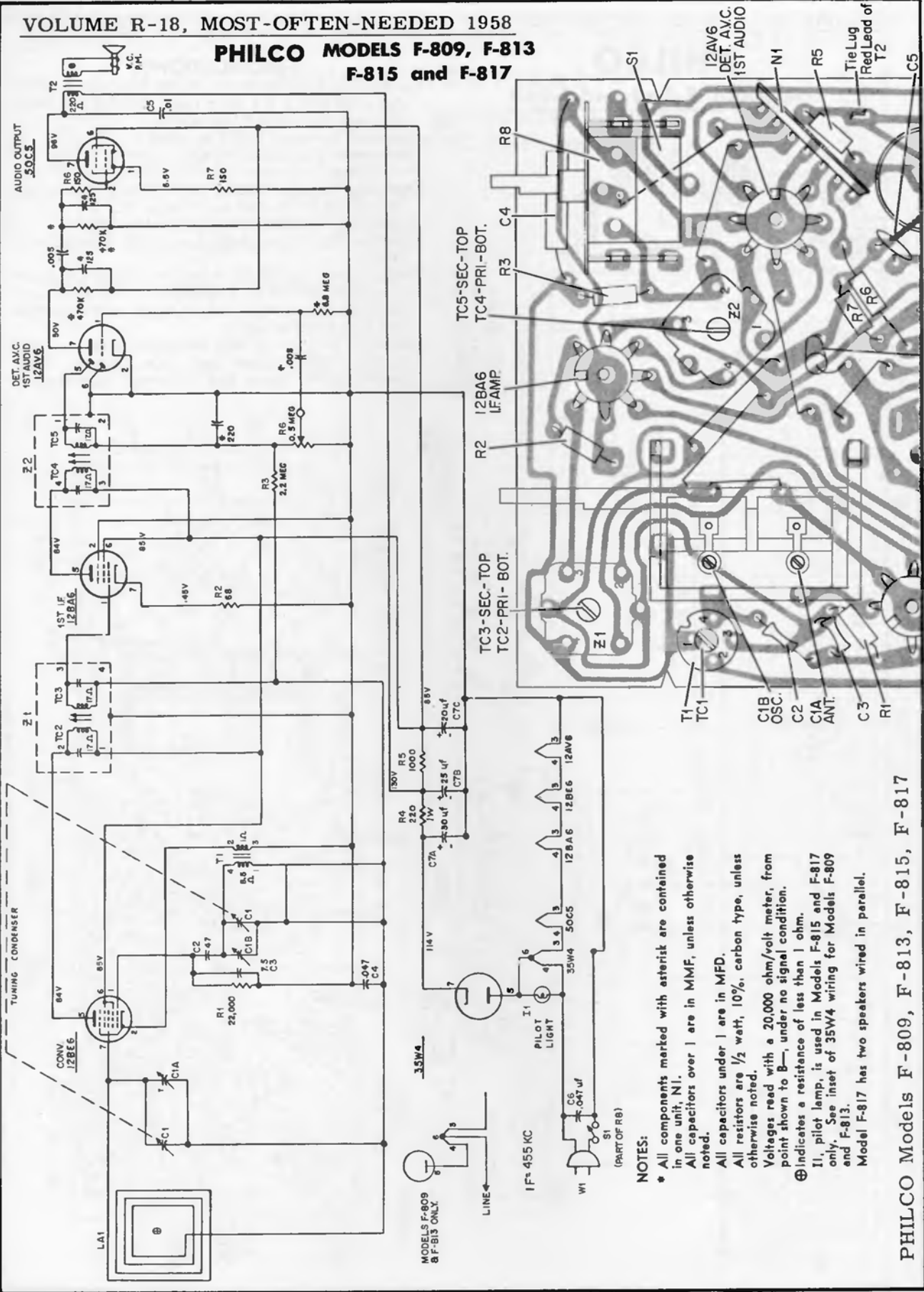

**NOTES:**

- \* All components marked with asterisk are contained in one unit, N1.
- All capacitors over 1 are in MMF, unless otherwise noted.
- All capacitors under 1 are in MFD.
- All resistors are 1/2 watt, 10%, carbon type, unless otherwise noted.
- ⊕ Indicates a resistance of less than 1 ohm.
- ⊕ I1, pilot lamp, is used in Models F-815 and F-817 only. See inset of 35W4 wiring for Models F-809 and F-813.
- Model F-817 has two speakers wired in parallel.

PHILCO Models F-809, F-813, F-815, F-817

# PHILCO HOME RADIO

## AM/FM MODEL F-974

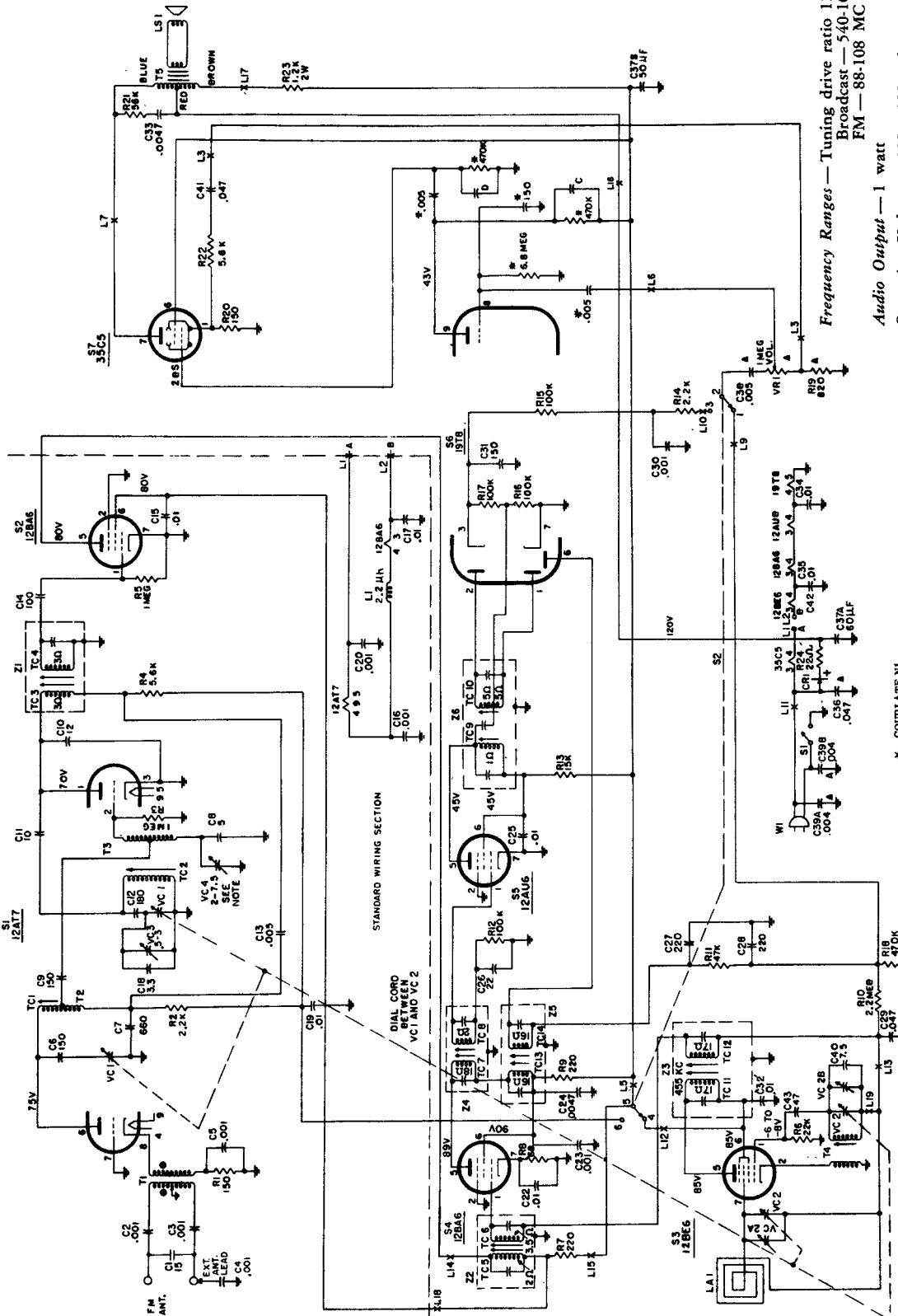

Frequency Ranges — Tuning drive ratio 12:1  
 Broadcast — 540-1620 KC  
 FM — 88-108 MC

Audio Output — 1 watt

Operating Voltage — 105 - 120 volts, a.c./d.c.

Power Consumption — 40 watts

Antennas — AM — Built in high impedance, pancake loop  
 FM — Line cord with provision for connecting external antenna.

Intermediate Frequency — AM 455 KC  
 FM 10.7 MC

\* CAPLATE N1  
 \* PART OF STANDARD WIRING  
 \* INDICATES LESS THAN 1 OHM  
 \* CONDENSERS C + D = 250 μf

ALL RESISTORS ARE 1/2 WATT, 10% UNLESS OTHERWISE NOTED.  
 ALL CAPACITORS ABOVE 1 ARE IN μf UNLESS OTHERWISE NOTED. ALL CAPACITORS BELOW 1 ARE μf.

VC4 IS A FACTORY ADJUSTMENT AND SHOULD NOT REQUIRE FUTURE ADJUSTMENT UNLESS RE-PLACED. IT MINIMIZES OSCILLATOR RADIATION. TO ADJUST, TUNE RADIO TO 100 MC AND ADJUST VC4 FOR MINIMUM INDICATION ON A FIELD STRENGTH METER TUNED TO THE OSC FREQ.

**PHILCO MODELS F-1372, F-1372X, F-1374 and F-1402**

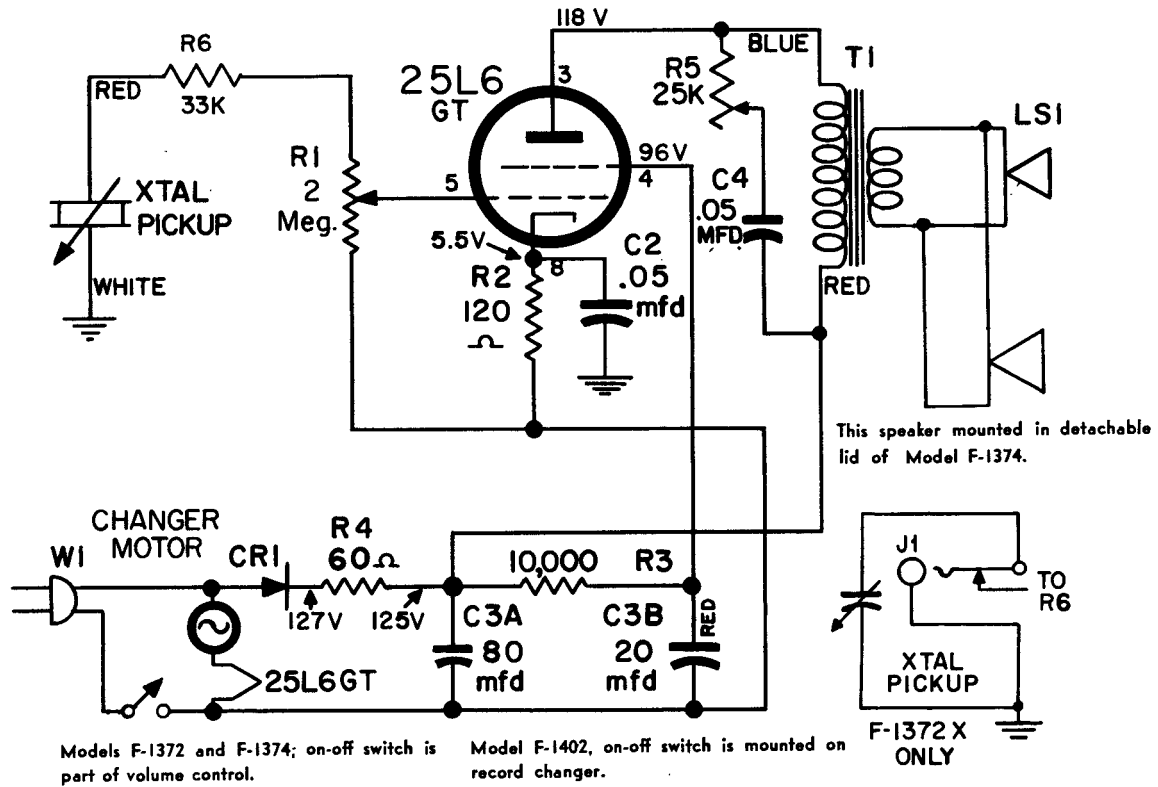

**LEAD DRESS**

R4, the surge limiting resistor, should be dressed up in the air and all leads and components kept away. This resistor operates at a high temperature that could damage lead insulation or cause value changes in components in contact with it.

**RECORD PLAYER (F-1372 and F-1374 Only)**

Tone Arm Assy.	35-2780
Cartridge and needle assy.	325-8012
Knob, cartridge flip-over	54-8333
Needle, 78 RPM	325-8013
Needle, LP	325-8013-1
Needle pressure spring	28-11728
Retaining ring, tone arm	1W42296FA3
Screw, knob	28-11729
Shaft and support assy., tone arm	76-11359
Spring, tone arm	28-10376-3
Washer, tone arm	28-10377
Bushing, tone arm	28-10374

**PHILCO PHONOGRAPH MODEL F-1404**

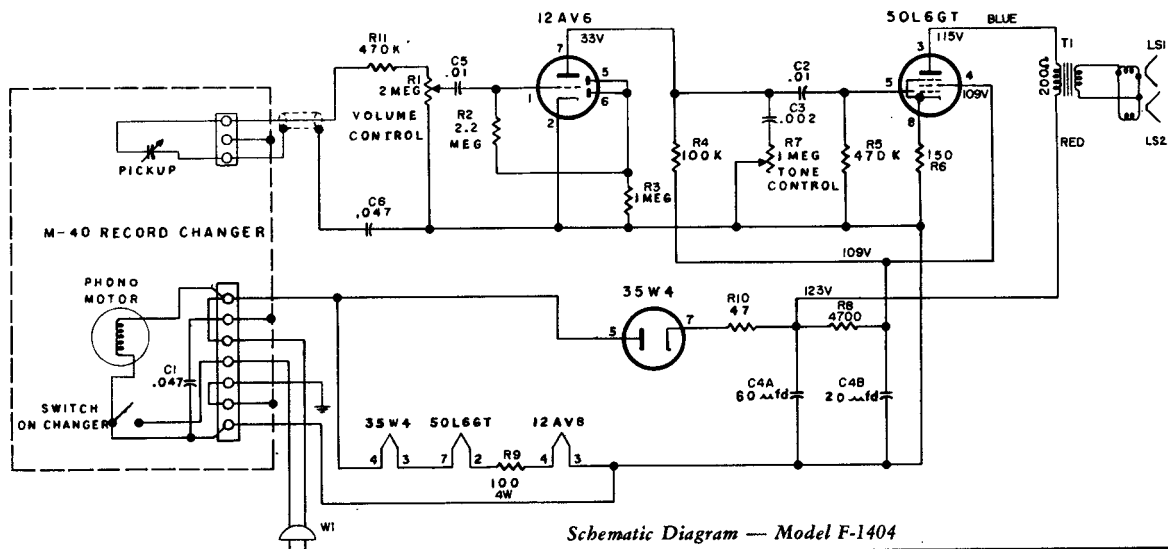

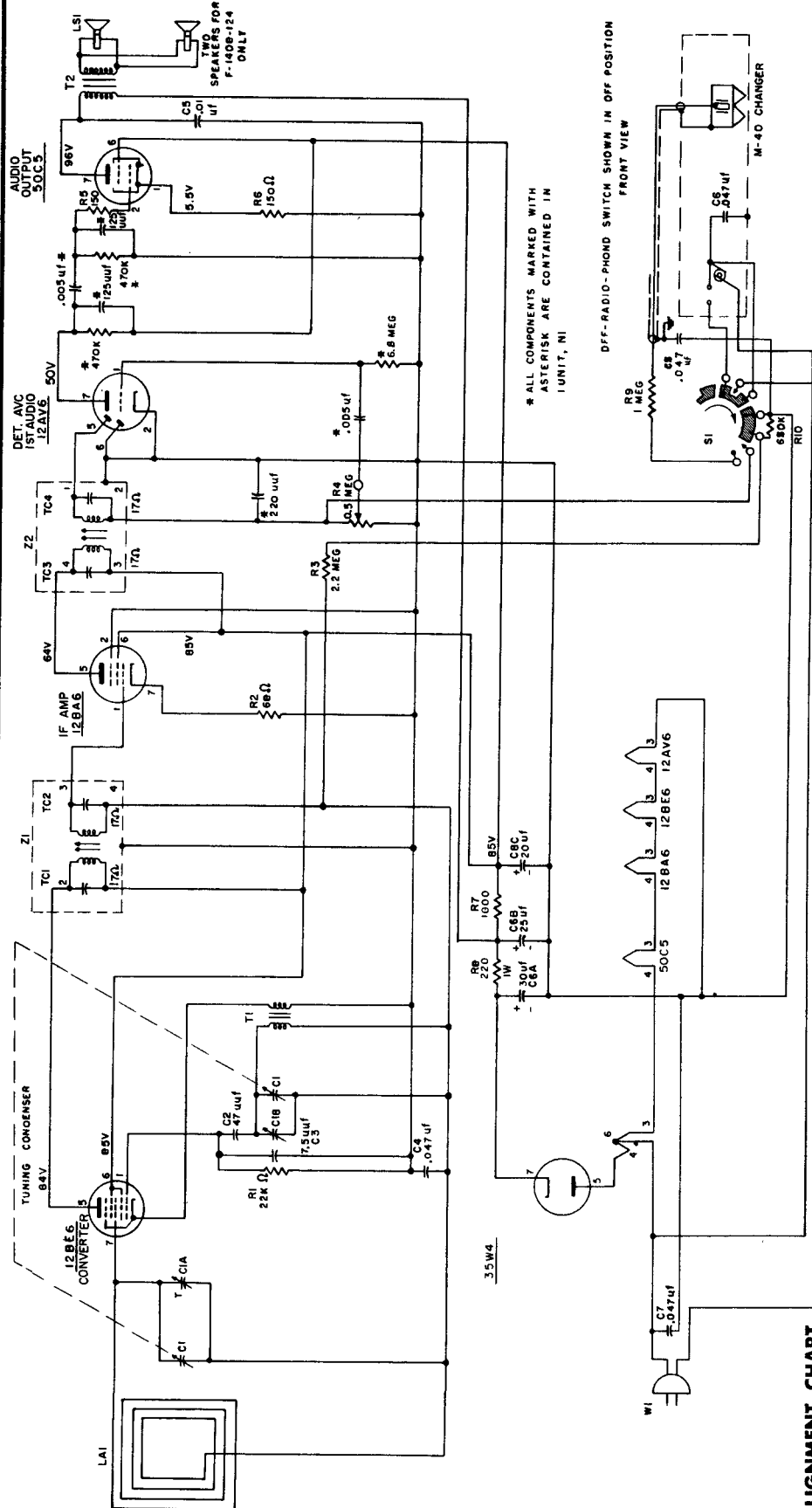

**PHILCO**

**MODELS F-1406 AND F-1408  
CODE 124**

*Frequency Range—540 KC to 1620 KC.  
Intermediate Frequency—455 KC.  
Audio Output—9 watts.  
Power Consumption—30 watts.  
Operating Voltage—105 to 120 volts, 60 cycle.*

**ALIGNMENT CHART**

STEP	SIGNAL GENERATOR		RADIO		ADJUST
	CONNECTION TO RADIO	DIAL SETTING	DIAL SETTING	SPECIAL INSTRUCTIONS	
1.	Ground lead to B-; output lead through a .1 mf condenser to grid (pin 7) of 12BE6.	455 kc.	Tuning gang fully open.	Adjust tuning cores, in order given, for max. output. TC2 and TC4 are located on top of transformers.	TC4—2nd i-f sec. TC3—2nd i-f pri. TC2—1st i-f sec. TC1—1st i-f pri.
2.	Radiating loop (See note below).	1620 kc.	1620 kc.*	Adjust for maximum output.	C1-B—osc.
3.	Same as Step 2.	1500 kc.	1500 kc.	Adjust for maximum output.	C1-A—aerial.

\* For proper adjustment of the oscillator trimmer, fully open the tuning gang and insert a .006 inch non-metallic shim between the heel of the rotor and the top of the stator plates. Close the tuning gang sufficiently to hold the shim in place, and then remove the shim without disturbing the gang setting.

NOTE: Make up a 6-8 turn, 6 inch diameter loop from insulated wire, connect to signal-generator leads, and place near radio loop.

**PHILCO PHONOGRAPHS**  
**MODELS F-1600, F-1700, F-1702,**  
**F-1802, F-1803, and F-1805**

(Continued on page 129,  
 adjacent at right)

**ALIGNMENT CHART**

Step	Signal Generator	Freq.	Dial Setting	Special Instruct. Adjust
1	Ground lead to B—. Output lead through a .01 mfd cond. to pin 7 (input grid) of 12BE6 converter	455KC	Gang fully open	Sec., 2nd IF, top Z3 Pri., 2nd IF, bot. Z3 Sec., 1st IF, top Z2 Pri., 1st IF, bot. Z2
2	Radiating loop. See Note 1 below	1620KC	See Note 2 below	C1C, osc. trimmer
3	Same as step 2	1520KC	Tune radio to gen. signal	C1B, mixer grid trimmer C1A, ant. trimmer
4	Same as step 2	580KC	Tune radio to gen. signal	Sec., RF trans., top Z1
5	Repeat steps 3 and 4 until no further improvement is obtained.			

Note 1: Make up a 6-8 turn, 6 inch diameter loop from insulated wire, connect to signal-generator leads and place near radio loop antenna.  
 Note 2: To set the tuning gang to 1620KC — place a 6 mil shim between rotor and stator, turn rotor until shim is held in place, remove shim.

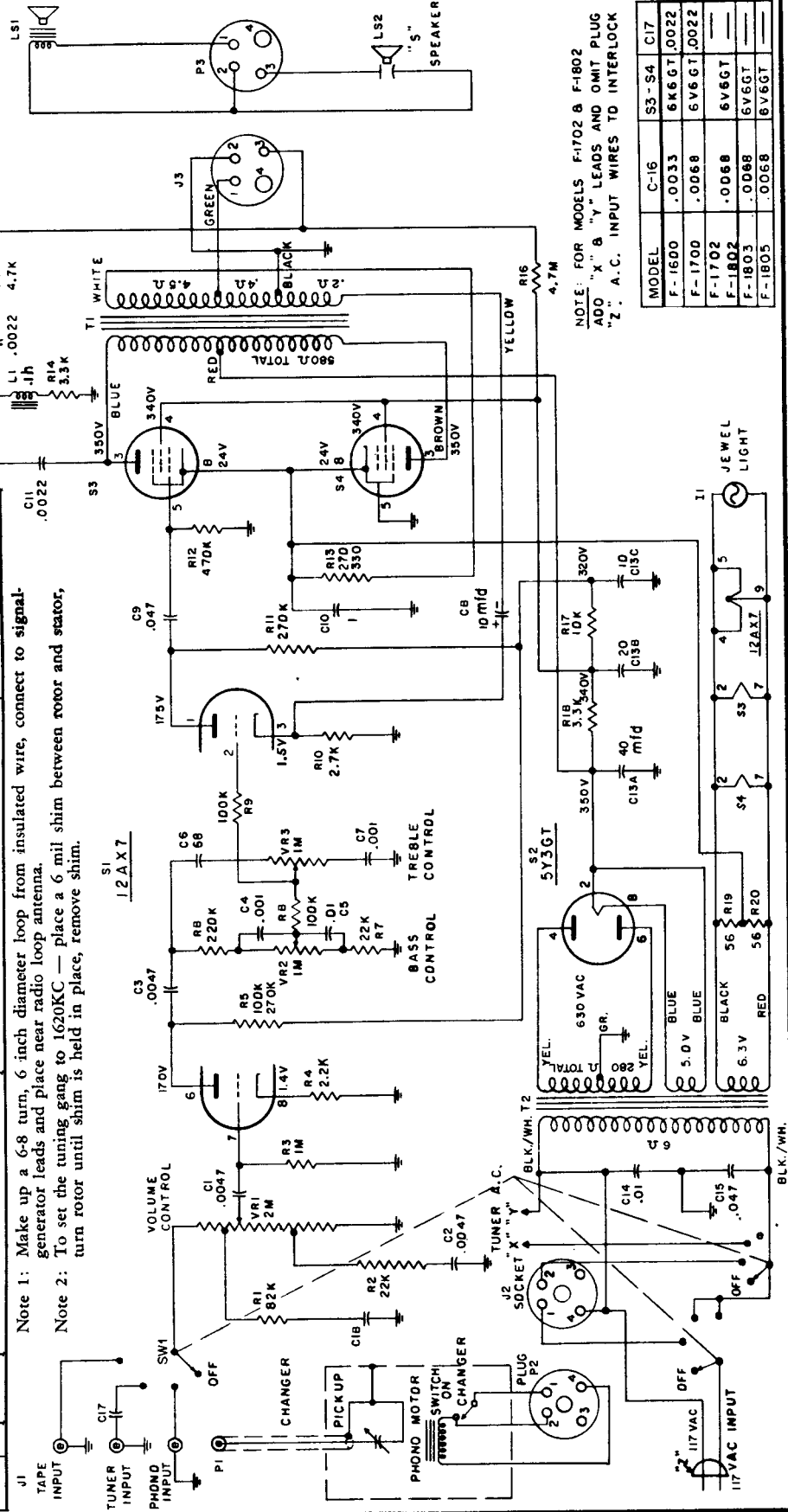

NOTE: FOR MODELS F-1702 & F-1802  
 ADD "X" & "Y" LEADS AND OMIT PLUG  
 "Z": A.C. INPUT WIRES TO INTERLOCK

MODEL	C-16	S3-S4	C17
F-1600	.0033	6K6GT	.0022
F-1700	.0068	6V6GT	.0022
F-1702	.0068	6V6GT	—
F-1802	.0068	6V6GT	—
F-1803	.0068	6V6GT	—
F-1805	.0068	6V6GT	—

Amplifier Schematic Diagram for Models F-1600, F-1700, F-1702, F-1802, F-1803 and F-1805



**PHILCO PHONOGRAPH MODELS — F-1600, F-1700, F-1702, F-1802, F-1803 and F-1805**

(Service material continued from page 128, at left)

**Circuit — Amplifier**—Three tube amplifier plus rectifier. Includes base, treble and volume controls and a selector switch. Inputs provided for external tuner and tape recorder.

**Tuner**—Model F-1702 employs the RT-100 AM tuner. Tuner includes three tubes, separate power supply and crystal detector. Models F-1802, F-1803 and F-1805 employ the RT-201 AM-FM tuner.

**Audio Output** — Model F-1600 — 6 watts. Models F-1700, F-1702, F-1802, F-1803 and F-1805 — 10 watts.

**Operating Voltage** — 105 to 120 volts, 60 cycles, a-c.

**Power Consumption** — Models F-1600 and F-1700 — 60 watts. Models F-1702, F-1802, F-1803 and F-1805 — 100 watts.

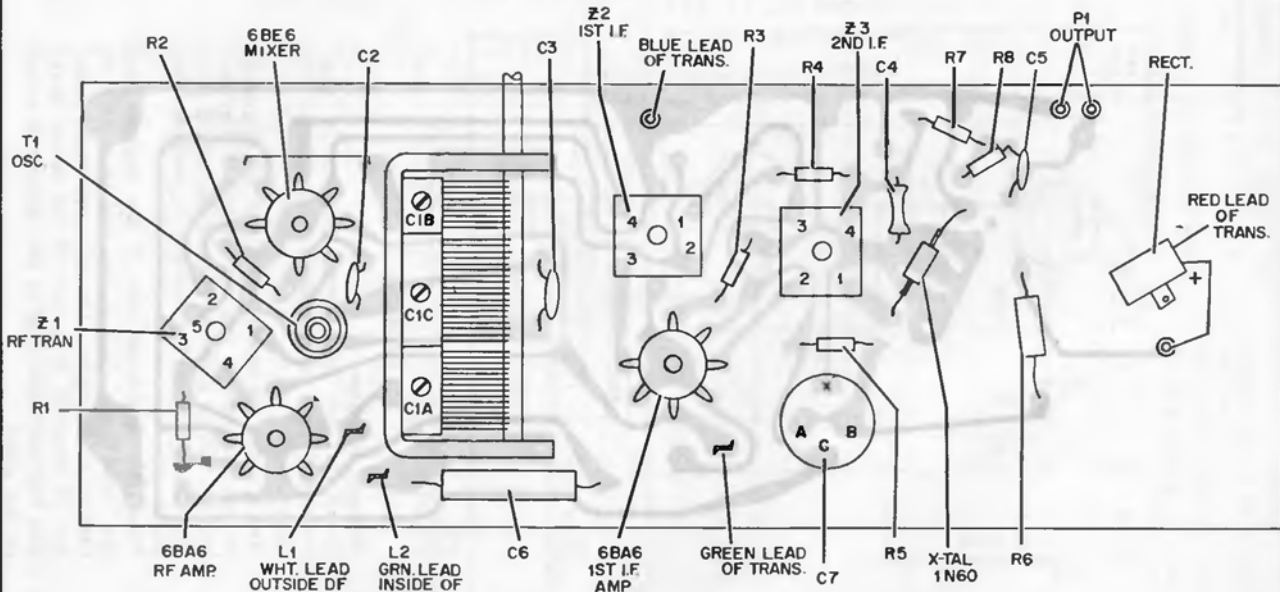

RT-100 Tuner Composite View, Component Layout of Printed Panel

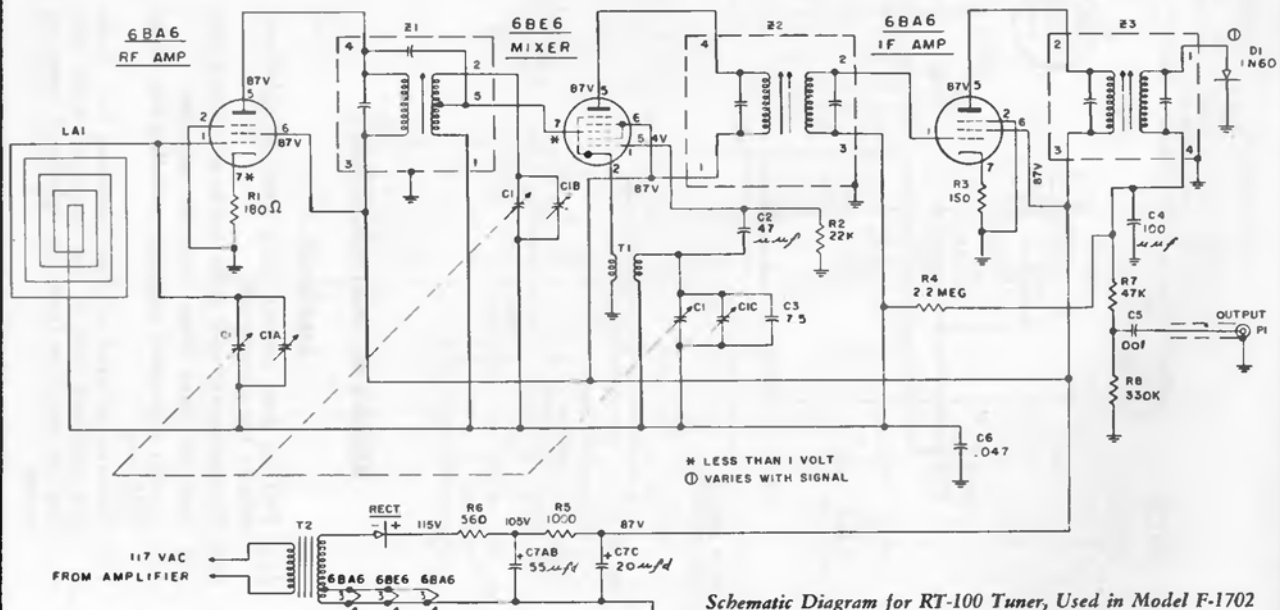

Schematic Diagram for RT-100 Tuner, Used in Model F-1702

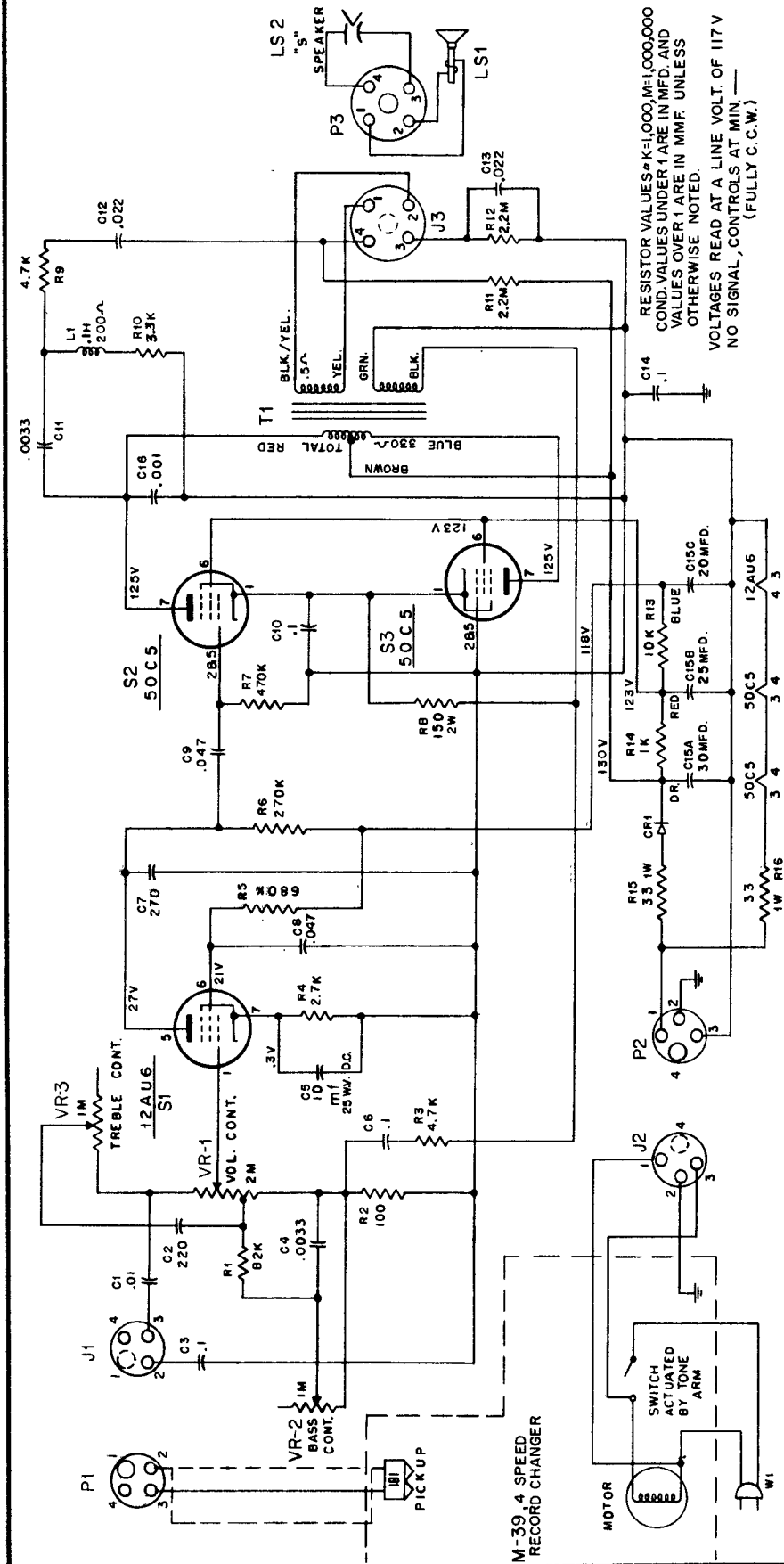

**PHILCO PHONOGRAPH**

**MODEL F-1500**

**CHANGER**

- (1) Remove amplifier.
- (2) Check that the "hold-down" bolts are in "play" position (Head of bolt flush with changer base plate).
- (3) Reach under the motor board and flip the toggle on the bottom of the right-hand "hold-down" bolt. It will be easier to operate the toggle if the right-hand side of the changer is pressed downward.
- (4) Raise the right-hand side of the changer until the "hold-down" bolt is free and then slide the changer to the right. The left-hand "hold-down" bolt is mounted in a slot of the motor board. The bolt will slide free as the changer is moved to the right.

**REMOVAL INSTRUCTIONS**

**AMPLIFIER**

- (1) Pull the three control knobs from the right-hand side of the phonograph.
- (2) Remove metal grill from inside of phonograph.
- (3) Pull the three plugs from the amplifier.
- (4) Loosen right-hand amplifier mounting nut, about half way.
- (5) Remove left-hand amplifier mounting nut. Raise the left-hand side of the amplifier while sliding the amplifier from the right-hand mounting screw.

# PHILCO HI-FIDELITY PHONOGRAPHS

MODELS F-1800, F-1801 and F-1804

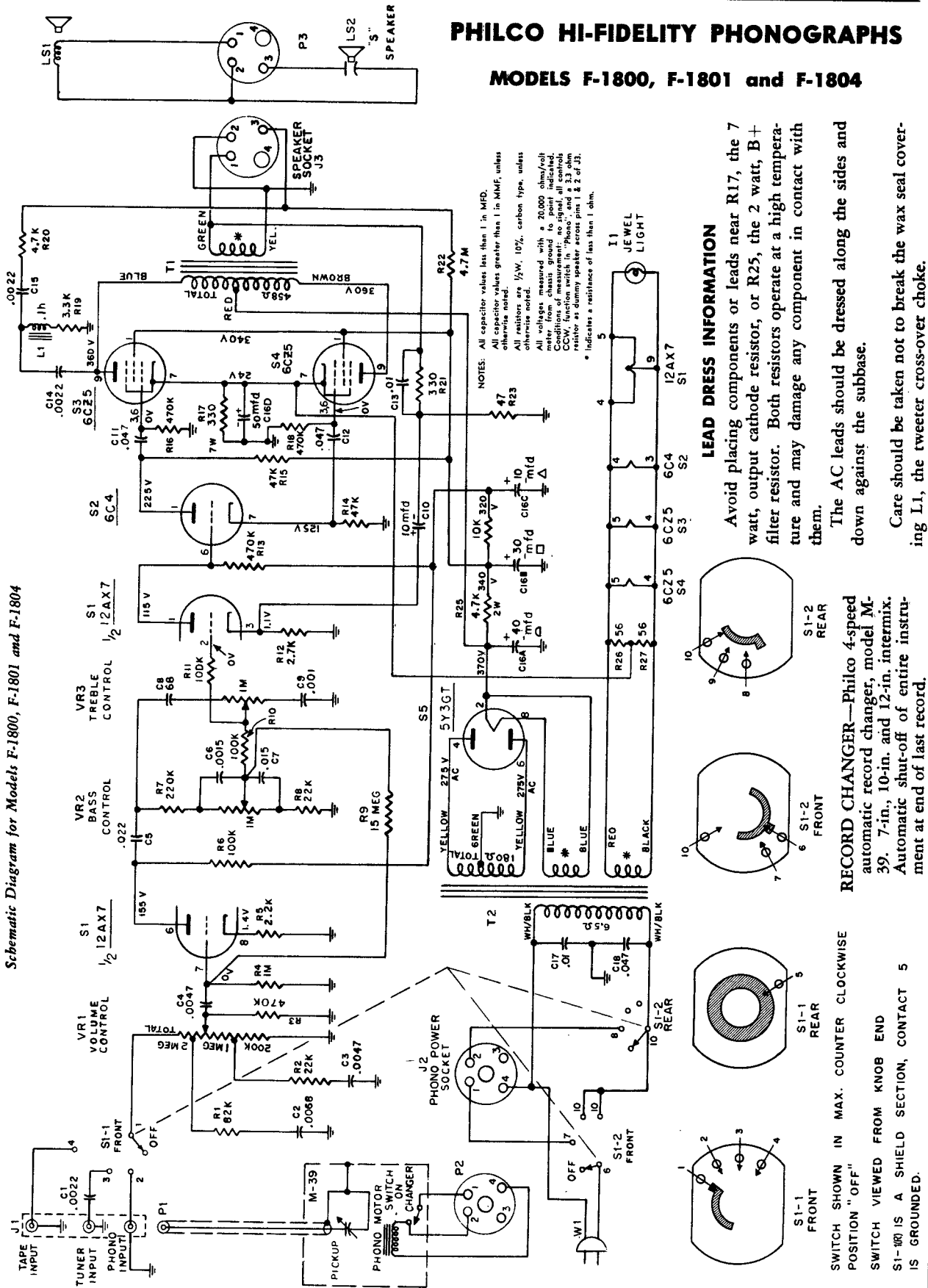

### LEAD DRESS INFORMATION

Avoid placing components or leads near R17, the 7 watt, output cathode resistor, or R25, the 2 watt, B+ filter resistor. Both resistors operate at a high temperature and may damage any component in contact with them.

The AC leads should be dressed along the sides and down against the subbase.

Care should be taken not to break the wax seal covering L1, the tweeter cross-over choke.

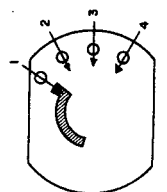
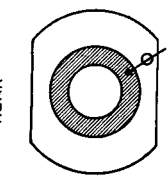
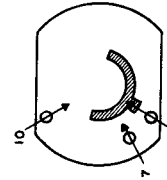
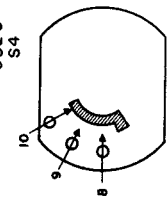

**RECORD CHANGER**—Philco 4-speed automatic record changer, model M-39. 7-in., 10-in. and 12-in. intermix. Automatic shut-off of entire instrument at end of last record.

SWITCH SHOWN IN MAX. COUNTER CLOCKWISE POSITION "OFF"

SWITCH VIEWED FROM KNOB END

S1-10 IS A SHIELD SECTION, CONTACT 5 IS GROUNDED.

NOTES: All capacitor values less than 1 in MFD.  
All capacitor values greater than 1 in M.M.F., unless otherwise noted.  
All resistors are 1/2W, 10% carbon type, unless otherwise noted.  
All voltages measured with a 20,000 ohms/volt meter from chassis ground to point indicated.  
Conditions of measurement: no signal, all controls set for normal operation.  
Phono 1 and 2 ohm resistors are dummy resistors.  
\* Indicates a resistance of less than 1 ohm.

# PHILCO AUTO RADIO

MODEL - C-5705-P-5701

Models P5701 (Mopar 848) and C5705 (Mopar 847) are electrically identical except that Model C5705 has two pilot lamps, a rear seat speaker socket, a fader control, and a tone control (with C22 & C23).

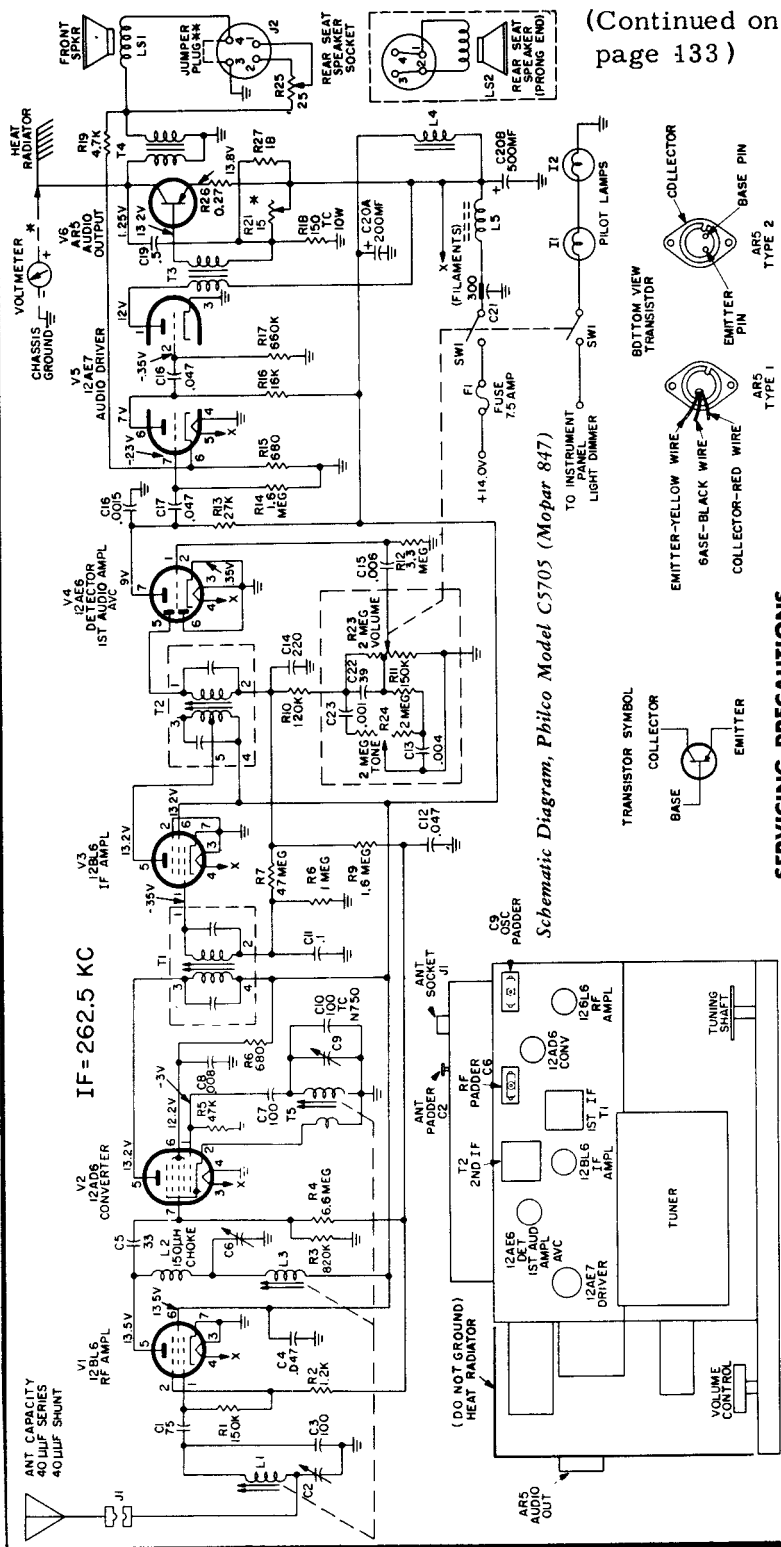

(Continued on page 133)

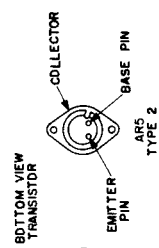

## SERVICING PRECAUTIONS

A-C leakage from measuring instruments or soldering irons may damage the transistor. All transistor measurements should be made with a battery-operated instrument. When soldering is necessary, disconnect set from power source.

Do not operate these receivers with the speaker disconnected, as transient voltages across an unloaded output transformer may damage the transistor.

When installing a new transistor, a good physical and electrical contact must be established between the collector and the heat radiator; care must be exercised when soldering, since excessive heat may melt the internal junctions. To adjust the bias, first make sure that the bias control, R21, is set at the center of its range. Then adjust the bias control for 500 ma. collector current, or for 1.25 volts, d.c., across the output transformer primary, with no input signal. (This bias control is "HOT" to ground — use insulated adjustment tool!)

- NOTES
- 1 ALL RESISTANCE VALUES ARE IN OHMS ± 10%, 1/2 WATT, UNLESS OTHERWISE INDICATED.
  - 2 ALL CAPACITANCE VALUES OF 1.0 AND ABOVE ARE IN MMF ± 20%, AND ALL VALUES BELOW 1.0 ARE IN PF ± 20%, UNLESS OTHERWISE INDICATED.
- \* ADJUST FOR 500MA COLLECTOR CURRENT OR 1.25V DC DROP ACROSS OUTPUT TRANSFORMER PRIMARY (NO SIGNAL 14V INPUT), DO NOT USE A VACUUM TUBE VOLTMETER FOR THIS MEASUREMENT.
- \*\* REMOVE JUMPER PLUG FOR REAR SEAT SPEAKER INSTALLATION.

VOLTAGE MEASUREMENTS WERE MADE WITH SET OPERATING FROM 140-VOLT D-C SUPPLY; TUNING CONTROL SET AT LOW-FREQUENCY END OF BAND; NO SIGNAL INPUT. ALL MEASUREMENTS ARE FROM POINT INDICATED TO CHASSIS UNLESS OTHERWISE SPECIFIED. OSCILLATOR GRID VOLTAGE WAS MEASURED WITH AN ELECTRONIC VOLTMETER HAVING A ONE-MEGOHM PROBE ISOLATING RESISTOR. ALL OTHER MEASUREMENTS WERE TAKEN WITH A 20,000-OHMS PER-VOLT METER.

DC RESISTANCES	
L1	1.0 OHMS
L2	1.0 OHMS
L3	1.0 OHMS
L4	1.0 OHMS
L5	1.0 OHMS
L6	1.0 OHMS
L7	1.0 OHMS
L8	1.0 OHMS
L9	1.0 OHMS
L10	1.0 OHMS
L11	1.0 OHMS
L12	1.0 OHMS
L13	1.0 OHMS
L14	1.0 OHMS
L15	1.0 OHMS
L16	1.0 OHMS
L17	1.0 OHMS
L18	1.0 OHMS
L19	1.0 OHMS
L20	1.0 OHMS
L21	1.0 OHMS
L22	1.0 OHMS
L23	1.0 OHMS
L24	1.0 OHMS
L25	1.0 OHMS
L26	1.0 OHMS
L27	1.0 OHMS
L28	1.0 OHMS
L29	1.0 OHMS
L30	1.0 OHMS
L31	1.0 OHMS
L32	1.0 OHMS
L33	1.0 OHMS
L34	1.0 OHMS
L35	1.0 OHMS
L36	1.0 OHMS
L37	1.0 OHMS
L38	1.0 OHMS
L39	1.0 OHMS
L40	1.0 OHMS
L41	1.0 OHMS
L42	1.0 OHMS
L43	1.0 OHMS
L44	1.0 OHMS
L45	1.0 OHMS
L46	1.0 OHMS
L47	1.0 OHMS
L48	1.0 OHMS
L49	1.0 OHMS
L50	1.0 OHMS
L51	1.0 OHMS
L52	1.0 OHMS
L53	1.0 OHMS
L54	1.0 OHMS
L55	1.0 OHMS
L56	1.0 OHMS
L57	1.0 OHMS
L58	1.0 OHMS
L59	1.0 OHMS
L60	1.0 OHMS
L61	1.0 OHMS
L62	1.0 OHMS
L63	1.0 OHMS
L64	1.0 OHMS
L65	1.0 OHMS
L66	1.0 OHMS
L67	1.0 OHMS
L68	1.0 OHMS
L69	1.0 OHMS
L70	1.0 OHMS
L71	1.0 OHMS
L72	1.0 OHMS
L73	1.0 OHMS
L74	1.0 OHMS
L75	1.0 OHMS
L76	1.0 OHMS
L77	1.0 OHMS
L78	1.0 OHMS
L79	1.0 OHMS
L80	1.0 OHMS
L81	1.0 OHMS
L82	1.0 OHMS
L83	1.0 OHMS
L84	1.0 OHMS
L85	1.0 OHMS
L86	1.0 OHMS
L87	1.0 OHMS
L88	1.0 OHMS
L89	1.0 OHMS
L90	1.0 OHMS
L91	1.0 OHMS
L92	1.0 OHMS
L93	1.0 OHMS
L94	1.0 OHMS
L95	1.0 OHMS
L96	1.0 OHMS
L97	1.0 OHMS
L98	1.0 OHMS
L99	1.0 OHMS
L100	1.0 OHMS

## MODEL P-5701 AND C-5705

To correct audio frequency response the 1st audio plate load resistor (R13) has been changed in value to 470,000 ohms, the 2nd audio grid return resistor (R14) has been changed to 4.7 megohms and the .0015 mfd, 1st audio plate bypass condenser, C16, has been removed.

## SETTING PUSH BUTTONS

1. Turn radio on and allow it to operate for fifteen minutes. Antenna should be fully extended.
2. Unlock push buttons by pulling them out.
3. Accurately tune in a station with manual tuning knob.
4. Lock one push button to that station by pushing firmly in.
5. Repeat above procedure for remaining push buttons.

VOLUME R-18, MOST-OFTEN-NEEDED 1958 RADIO SERVICING INFORMATION

PHILCO Models C-5705 and P-5701, Alignment Procedure, Continued

**GENERAL**—The cover must be removed in order to perform the alignment procedure. Allow the set and the test equipment to warm up for fifteen minutes before starting the alignment procedure. Make sure that all plugs and cables are connected to their proper receptacles.

**OUTPUT INDICATOR**—Connect the output indicator (an oscilloscope or a 1000-ohm-per-volt, a-c voltmeter) across the voice-coil terminals.

**SIGNAL GENERATOR**—Use an AM r-f signal generator with 30% modulation. Connect the ground lead to the chassis, and the output lead as indicated in the alignment chart.

**OUTPUT LEVEL**—Attenuate the signal-generator output throughout the procedure to hold the output indication below 1 volt.

**RADIO CONTROLS**—Set the volume control to maximum. Set the tone control to mid-range (in C5705 only). Set the tuning control as indicated in the alignment chart.

**DUMMY ANTENNA**—When making the r-f and antenna tuning adjustments, connect the signal-generator output lead through a 40- $\mu$ f. condenser to the antenna receptacle, and connect another 40- $\mu$ f. condenser from the antenna receptacle to the chassis.

ALIGNMENT CHART

STEP	SIGNAL GENERATOR		RADIO		
	CONNECTION TO RADIO	DIAL SETTING	DIAL SETTING	SPECIAL INSTRUCTIONS	ADJUST
1	Through a .05 $\mu$ f. condenser to mixer grid, pin 7, of 12AD6.	262.5 kc.	1605 kc.	Adjust in order given for maximum output.	T2 (top) — 2nd i-f secondary T2 (bottom) — 2nd i-f primary
2	Same as step 1.	262.5 kc.	1605 kc.	Same as step 1.	T1 (top) — 1st i-f secondary T1 (bottom) — 1st i-f primary
3	Through dummy antenna to J1 (antenna socket).	1605 kc.	1605 kc.	Adjust for maximum output.	C9—osc. padder C2—ant. padder C6—r-f padder
4				With radio and antenna installed in car, adjust for maximum output, using a weak station near 1200 kc.	C2—ant. padder

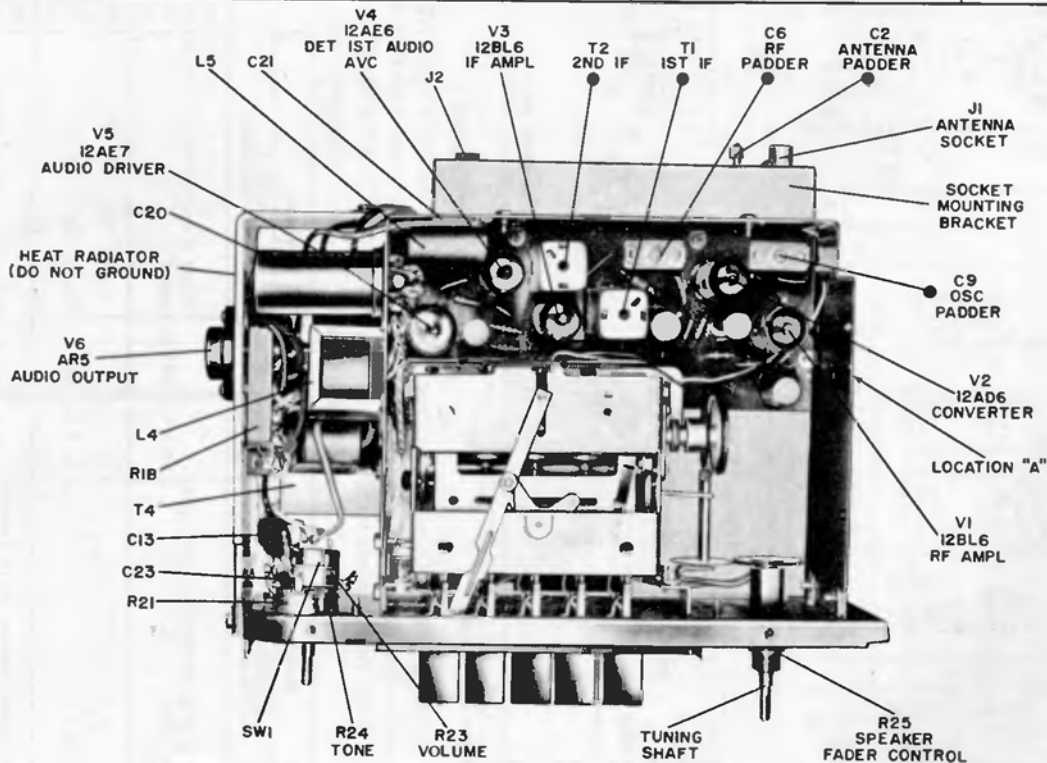

Top View of Philco Model C5705, Showing Alignment Points, Tubes, and Location of Parts

NOTE: Model P5701 is the same as Model C5705 with the following exceptions: the socket mounting bracket, the rear-seat speaker socket (J2), the speaker fader control (R25) and the tone control (R24) (with C22 & C23) are omitted; the antenna socket (J1) and the antenna padder (C2) are placed at location "A".

# PHILCO

PHILCO MODEL P-5702  
MOPAR MODEL 848

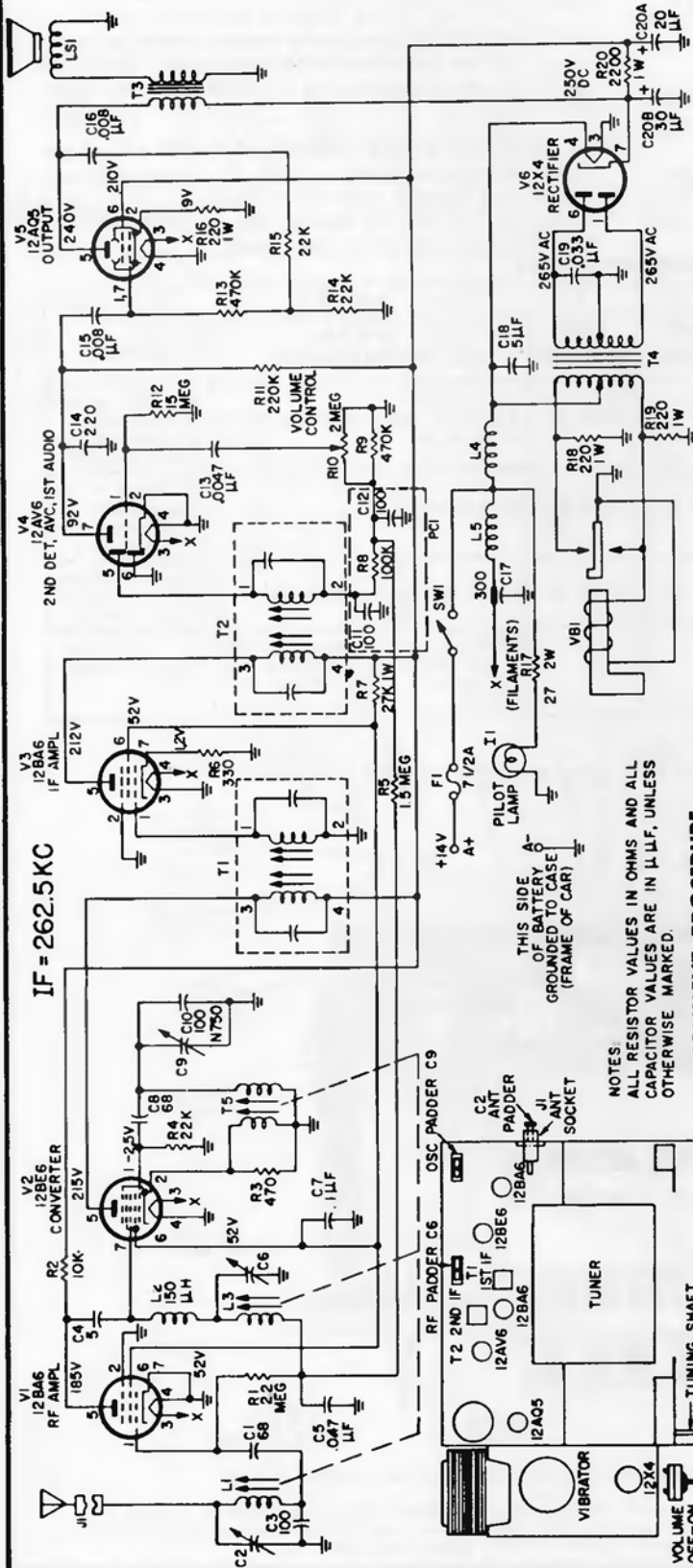

**ALIGNMENT PROCEDURE**  
SIGNAL GENERATOR — Use an AM r-f signal generator with 30% modulation. Connect the ground lead to the chassis, and the output lead as indicated in the alignment chart.

**OUTPUT INDICATOR** — Connect the output indicator (an oscilloscope or a 1000-ohms-per-volt, a-c voltmeter) across the voice-coil terminals.

**ALIGNMENT CHART**

STEP	SIGNAL GENERATOR CONNECTION TO RADIO		DIAL SETTING	RADIO SPECIAL INSTRUCTIONS		ADJUST
	DIAL SETTING	DIAL SETTING		DIAL SETTING	SPECIAL INSTRUCTIONS	
1	Through a .05 pf. condenser to mixer grid, pin 7, of 12BE6.	262.5 kc.	1605 kc.	Adjust in order given for maximum output.		T2 (top) — 2nd i-f secondary T2 (bottom) — 2nd i-f primary
2	Same as step 1.	262.5 kc.	1605 kc.	Same as step 1.		T1 (top) — 1st i-f secondary T1 (bottom) — 1st i-f primary
3	Through dummy antenna to J1 (antenna socket).	1605 kc.	1605 kc.	Adjust for maximum output.		C9—osc. padder C2—ant. padder C6—r-f padder
4				With radio and antenna installed in car, adjust for maximum output, using a weak station near 1200 kc.		C3—ant. padder

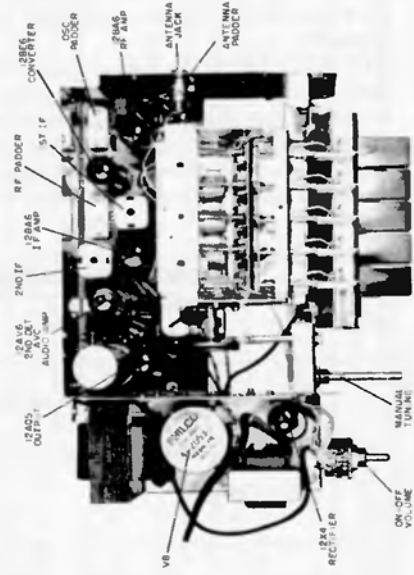

PHILCO AUTO RADIOS MODELS P-5703, C-5707 AND C-5709

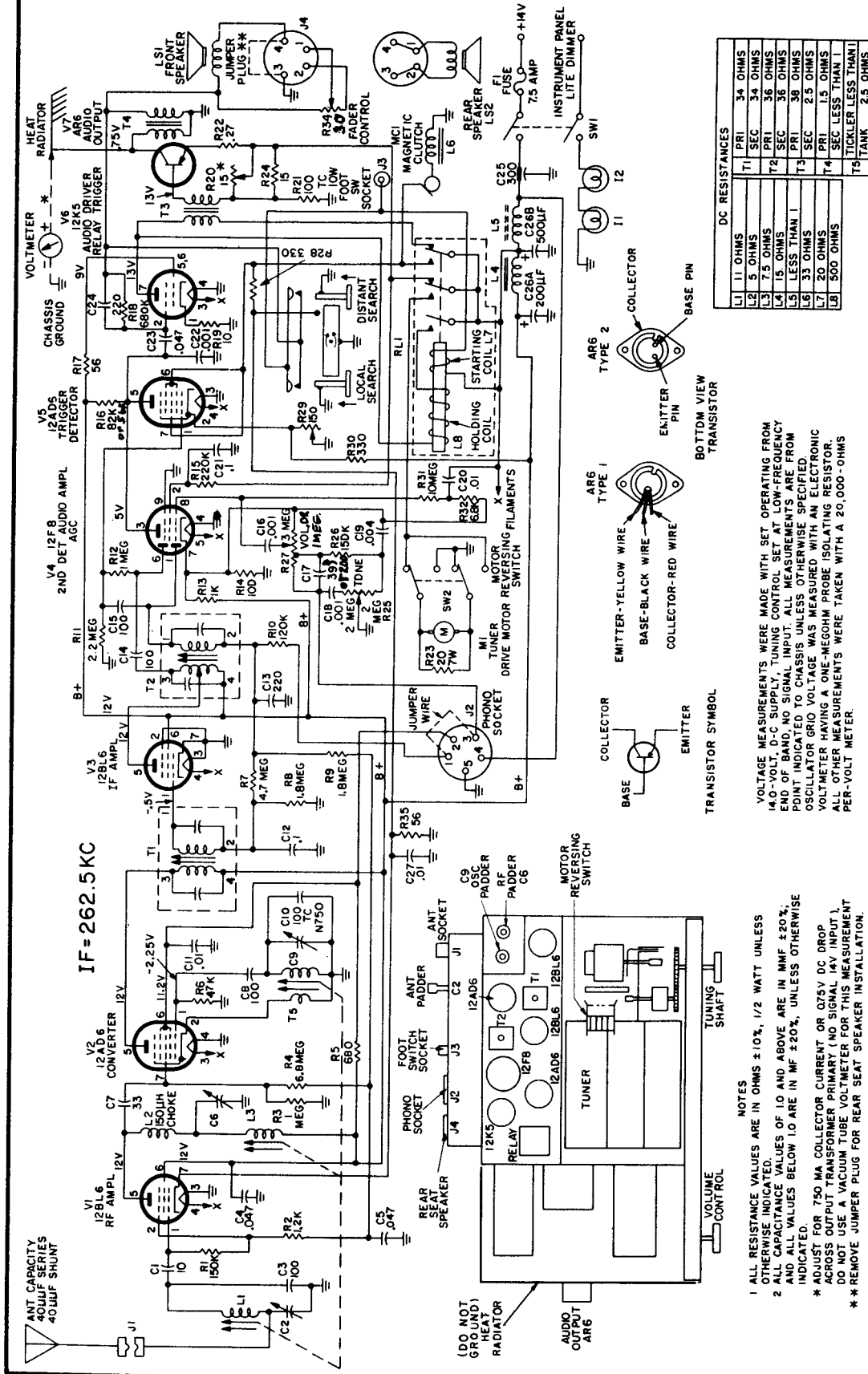

PHILCO AUTO RADIO MODELS P-5703, C-5707, C-5709

Models P5703 (Mopar 917HR), C5707 (Mopar 920HR), and C5709 (Mopar 921HR) are electrically identical except that Models C5707 and C5709 have two pilot lamps, a rear-seat-speaker socket, a fader control, and a foot switch socket.

VOLTAGE MEASUREMENTS WERE MADE WITH SET OPERATING FROM 140-170V, D-C SUPPLY, TUNING CONTROL SET AT LOW-FREQUENCY END OF BAND, NO SIGNAL INPUT. ALL MEASUREMENTS ARE FROM POINT INDICATED TO CHASSIS UNLESS OTHERWISE SPECIFIED. OSCILLATOR GRID VOLTAGE WAS MEASURED WITH AN ELECTRONIC VOLTMETER HAVING A ONE-MEGOHM PROBE ISOLATING RESISTOR. ALL OTHER MEASUREMENTS WERE TAKEN WITH A 20,000-OHMS PER-VOLT METER.

SETTING PUSH BUTTONS

1. Turn radio on and allow it to operate for fifteen minutes. Antenna should be fully extended.
2. Unlock push buttons by pulling them out.
3. Accurately tune in a station with manual tuning knob.
4. Lock one push button to that station by pushing firmly in.
5. Repeat above procedure for remaining push buttons.

- NOTES
- 1 ALL RESISTANCE VALUES ARE IN OHMS ± 10%, 1/2 WATT UNLESS OTHERWISE INDICATED.
  - 2 ALL CAPACITANCE VALUES OF 1.0 AND ABOVE ARE IN MMF ± 20% AND ALL VALUES BELOW 1.0 ARE IN MF ± 20%, UNLESS OTHERWISE INDICATED.
- \* ADJUST FOR 750 MA COLLECTOR CURRENT OR 075V DC DROP ACROSS OUTPUT TRANSFORMER PRIMARY (NO SIGNAL 14V INPUT). DO NOT USE A VACUUM TUBE VOLTMETER FOR THIS MEASUREMENT.
- \*\* REMOVE JUMPER PLUG FOR REAR SEAT SPEAKER INSTALLATION.

VOLUME R-18, MOST-OFTEN-NEEDED 1958 RADIO SERVICING INFORMATION

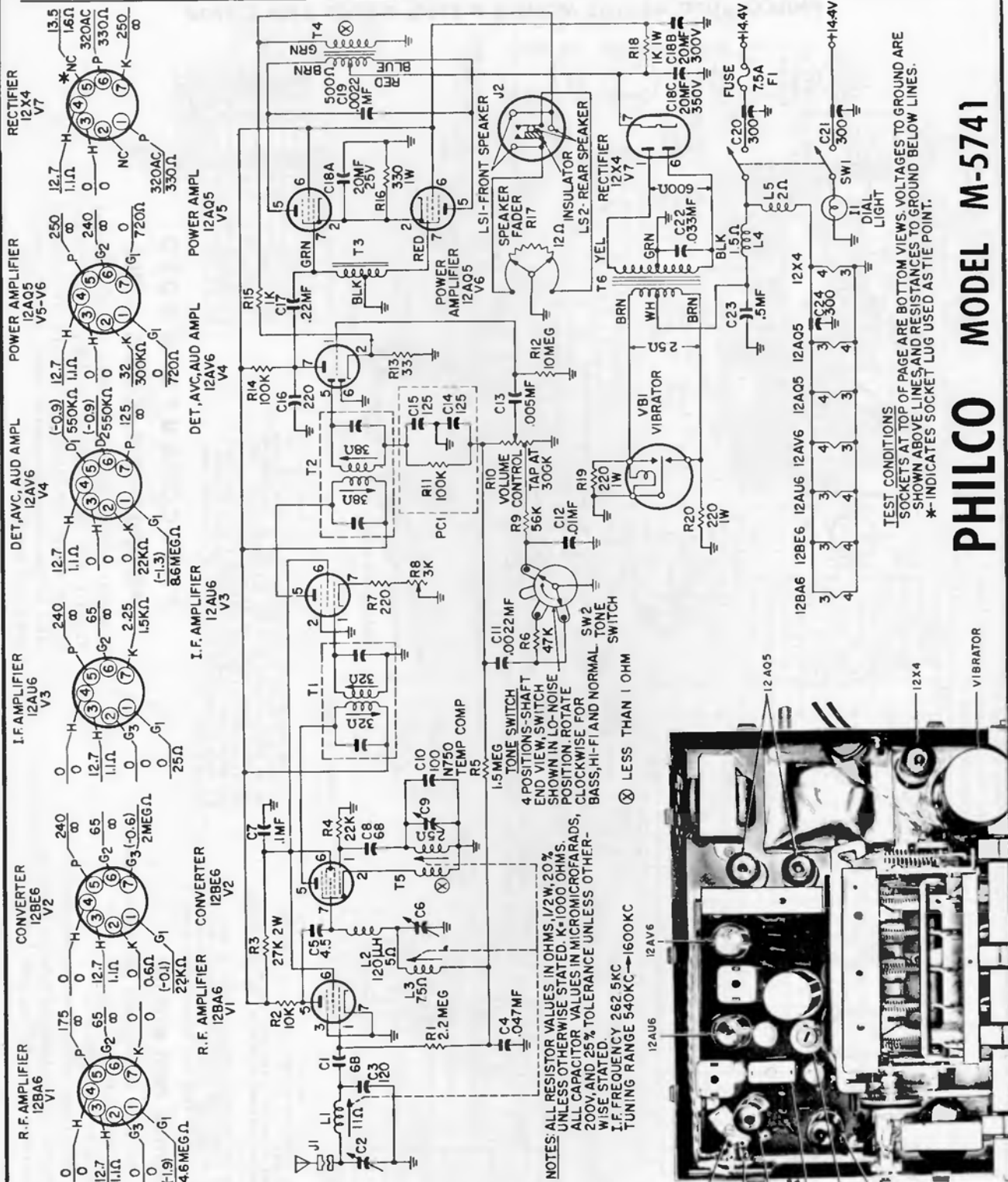

VOLTAGE MEASUREMENTS

- 1-VOLTAGES IN PARENTHESIS ARE MEASURED WITH VTVM.
- 2-ALL OTHER DC VOLTAGES MEASURED WITH 20,000Ω/VOLT METER.
- 3-ALL AC VOLTAGES MEASURED WITH 1,000Ω/VOLT METER.
- 4-ALL VOLTAGES MEASURED WITH RESPECT TO CHASSIS.
- 5-ALL VOLTAGES MEASURED WITH +14.4 VOLTS INPUT WITH NEGATIVE GROUND.

RESISTANCE MEASUREMENTS

- 1-BATTERY LEAD REMOVED FROM SET.
- 2-NEGATIVE OHMMETER LEAD ON CHASSIS GROUND.
- 3-TONE SWITCH AND VOLUME CONTROL IN FULL CLOCKWISE POSITION.
- 4-VALUES SHOULD NOT VARY MORE THAN 20%.

NOTES: ALL RESISTOR VALUES IN OHMS, 1/2W, 20% UNLESS OTHERWISE STATED. K=1000 OHMS. ALL CAPACITOR VALUES IN MICROMICROFARADS, 200V AND 25% TOLERANCE UNLESS OTHERWISE STATED.  
 I.F. FREQUENCY 262.5KC  
 TUNING RANGE 540KC→1600KC

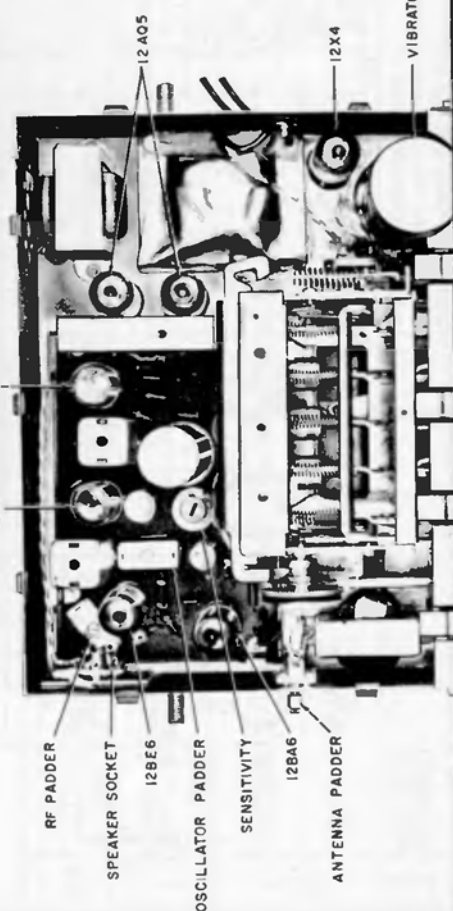

TEST CONDITIONS  
 SOCKETS AT TOP OF PAGE ARE BOTTOM VIEWS. VOLTAGES TO GROUND ARE SHOWN ABOVE LINES, AND RESISTANCES TO GROUND BELOW LINES.  
 \* - INDICATES SOCKET LUG USED AS TIE POINT.

PHILCO MODEL M-5741



Philco Model P-5801 (Mopar 848)

IF = 262.5 KC

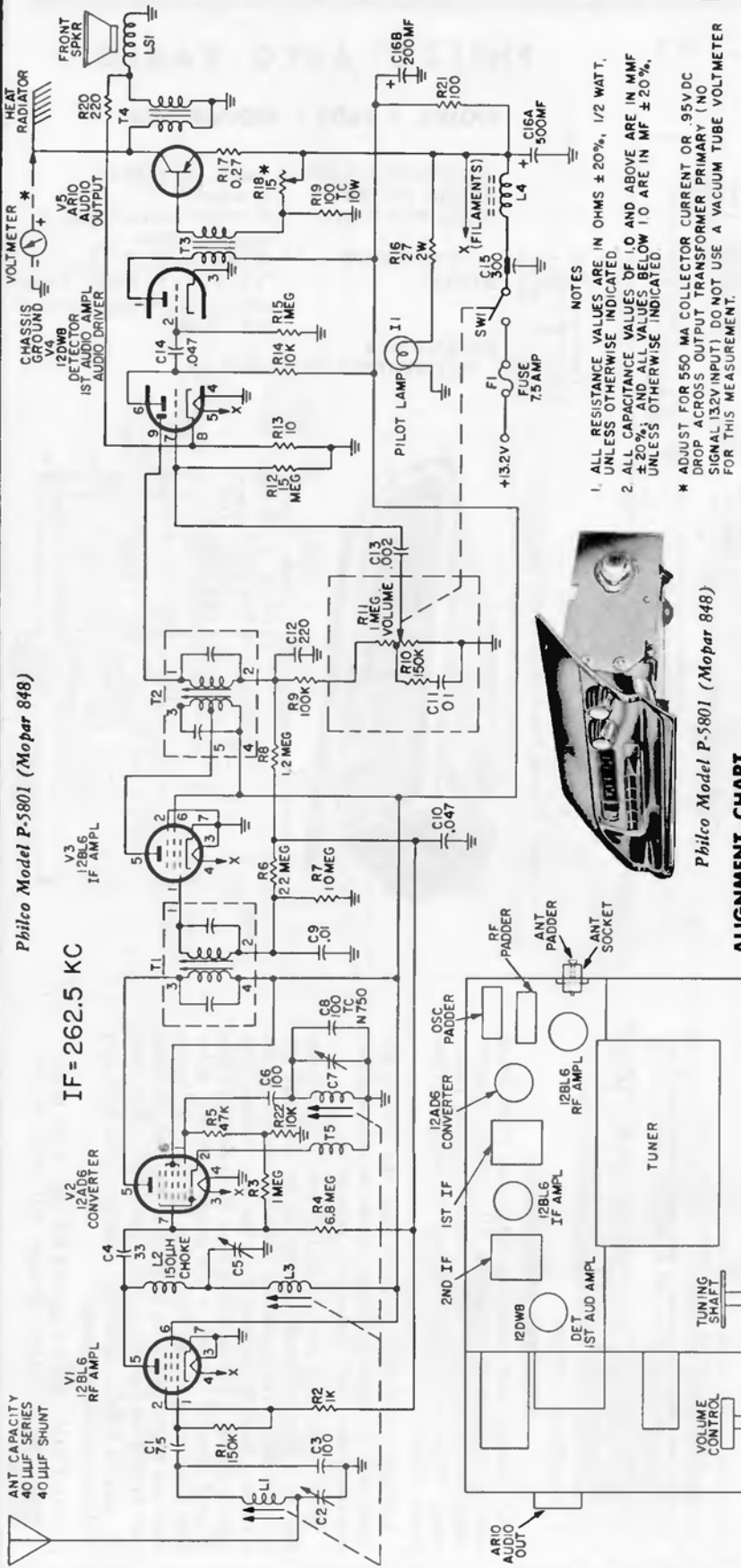

Philco Model P-5801 (Mopar 848)

NOTES

1. ALL RESISTANCE VALUES ARE IN OHMS ± 20%, 1/2 WATT, UNLESS OTHERWISE INDICATED
2. ALL CAPACITANCE VALUES OF 1.0 AND ABOVE ARE IN MMF ± 20%; AND ALL VALUES BELOW 1.0 ARE IN MF ± 20%, UNLESS OTHERWISE INDICATED

\* ADJUST FOR 550 MA COLLECTOR CURRENT OR .95VDC DROP ACROSS OUTPUT TRANSFORMER PRIMARY (NO SIGNAL 132V INPUT) DO NOT USE A VACUUM TUBE VOLTMETER FOR THIS MEASUREMENT.

ALIGNMENT CHART

STEP	SIGNAL GENERATOR		RADIO	
	CONNECTION TO RADIO	DIAL SETTING	SPECIAL INSTRUCTIONS	ADJUST
1	Through a .047 μf. condenser to mixer grid, pin 7, of 12AD6.	262.5 kc.	Adjust in order given for maximum output.	T2 (top) — 2nd i-f secondary T2 (bottom) — 2nd i-f primary
2	Same as step 1.	262.5 kc.	Same as step 1.	T1 (top) — 1st i-f secondary T1 (bottom) — 1st i-f primary
3	Through dummy antenna to J1 (antenna socket).	1605 kc.	Adjust for maximum output.	C7—osc. padder C2—ant. padder C5—r-f padder
4			With radio and antenna installed in car, adjust for maximum output, using a weak station near 1200 kc.	C2—ant. padder

**IMPORTANT:** When connecting radio to "A" supply, either in car or on test bench, polarity must be observed. "A + " lead is positive, "A - " is chassis ground.

PHILCO AUTO RADIO

MODEL P-5801

# PHILCO AUTO RADIO

## MODEL P-5803 — MOPAR 925

FREQUENCY RANGE 540 kc. to 1610 kc.  
 AUDIO OUTPUT 5 watts  
 PUSH BUTTONS 5 station selectors plus 2 search buttons  
 POWER INPUT 1.5 amp. at 13.2 volts, d.c.  
 AERIAL Vertical whip, fender mounting (40 uuf. series, 40 uuf. shunt)  
 FREQUENCY INTERMEDIATE 262.5 kc.

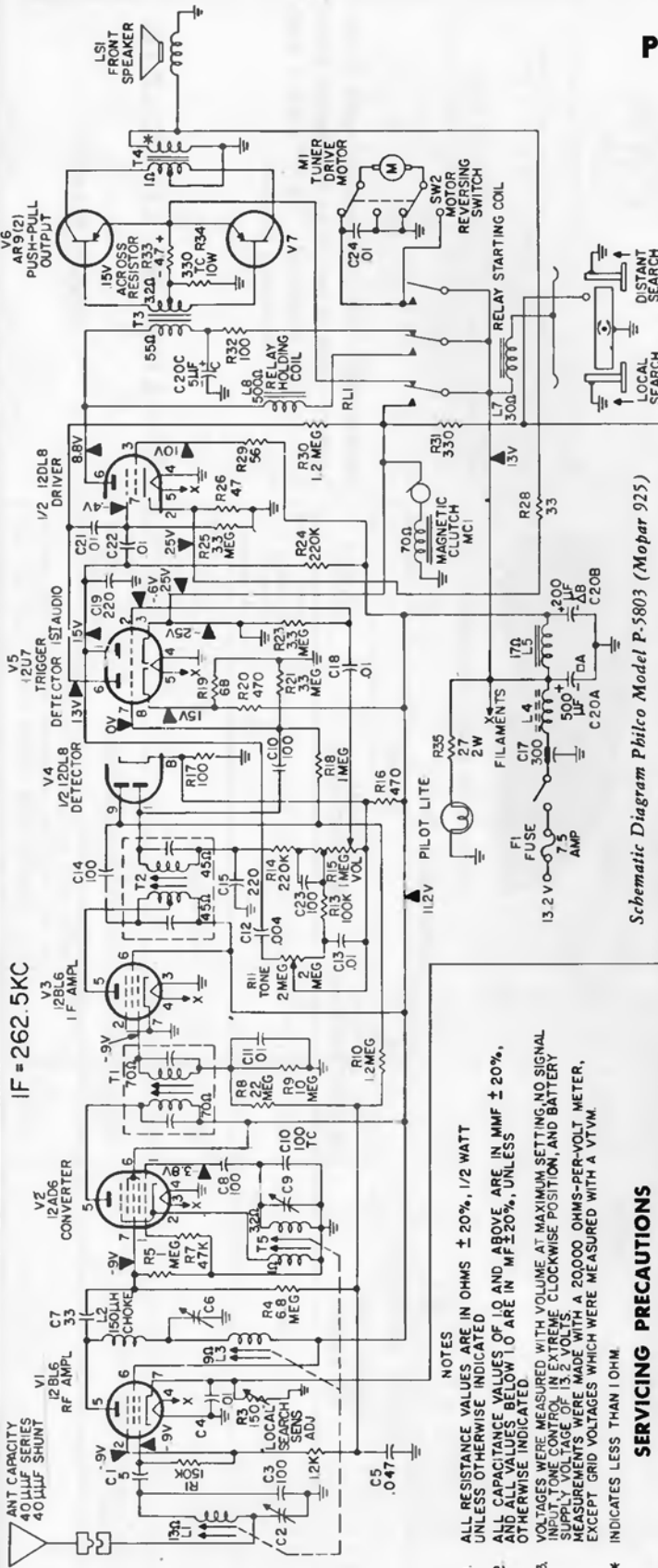
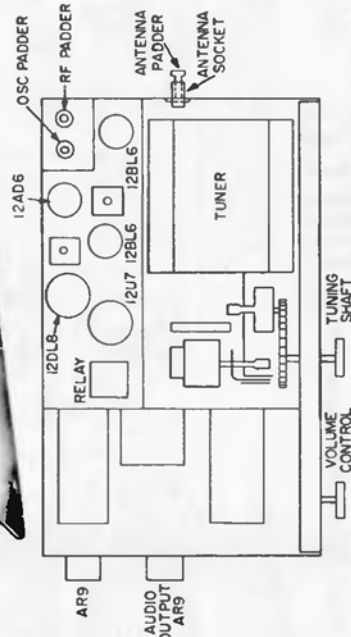
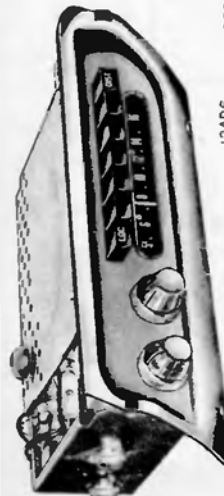

Schematic Diagram Philco Model P-5803 (Mopar 925)

IF = 262.5K

- NOTES
1. ALL RESISTANCE VALUES ARE IN OHMS  $\pm 20\%$ , 1/2 WATT UNLESS OTHERWISE INDICATED
  2. ALL CAPACITANCE VALUES OF 10 AND ABOVE ARE IN MMF  $\pm 20\%$ , AND ALL VALUES BELOW 10 ARE IN MF  $\pm 20\%$ , UNLESS OTHERWISE INDICATED
  3. VOLTAGES WERE MEASURED WITH VOLUME AT MAXIMUM SETTING, NO SIGNAL INPUT, TONE CONTROL IN EXTREME CLOCKWISE POSITION, AND BATTERY SUPPLY VOLTAGE OF 13.2 VOLTS. MEASUREMENTS WERE MADE WITH A 20000 OHMS-PER-VOLT METER, EXCEPT GRID VOLTAGES WHICH WERE MEASURED WITH A VTVM.
- \* INDICATES LESS THAN 1 OHM.

### SERVICING PRECAUTIONS

A-C leakage from measuring instruments or soldering irons may damage the transistors. All transistor measurements should be made with a battery-operated instrument. When soldering is necessary, disconnect set from power source.

Do not operate these receivers with the speaker disconnected, as transient voltages across an unloaded output transformer may damage the transistors.

When installing a new transistor, a good physical contact must be established between the collector and the heat radiator. The transistor shell (connected to the transistor base) is insulated from the heat radiator by a film of plastic. The transistor must be mounted to give a good physical contact — the plastic film will allow heat conduction to the plate—but **MUST NOT** make electrical contact with the heat radiator plate. Use caution to prevent damage to the plastic film. Care must be exercised when soldering, since excessive heat may melt the internal junctions.

**CAUTION:** Do not ground the base of any of the transistors or serious damage will result to the transistor.

# PHILCO AUTO RADIO

## MODEL C-5809

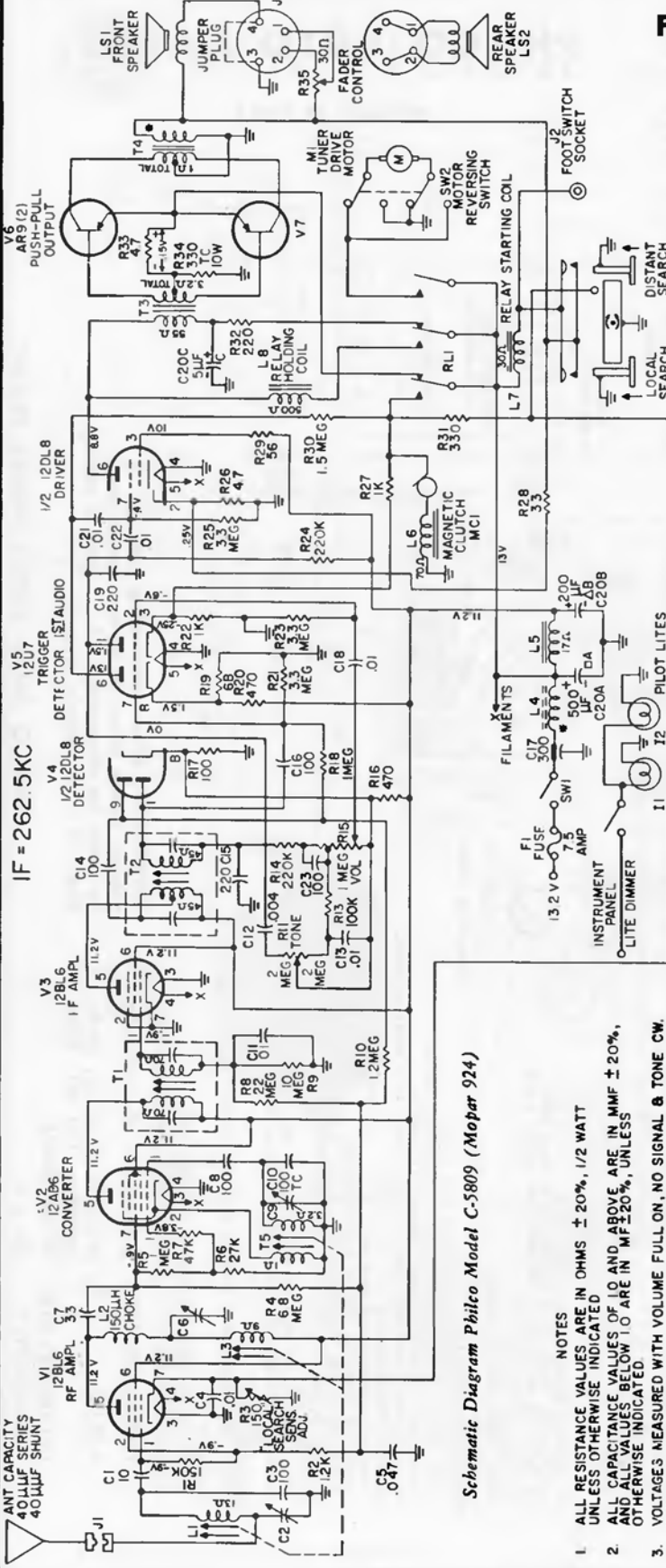

IF = 262.5KC

Schematic Diagram Philco Model C-5809 (Mopar 924)

- NOTES
1. ALL RESISTANCE VALUES ARE IN OHMS  $\pm 20\%$ , 1/2 WATT UNLESS OTHERWISE INDICATED.
  2. ALL CAPACITANCE VALUES OF 10 AND ABOVE ARE IN MMF  $\pm 20\%$ , AND ALL VALUES BELOW 10 ARE IN MF  $\pm 20\%$ , UNLESS OTHERWISE INDICATED.
  3. VOLTAGES MEASURED WITH VOLUME FULL ON, NO SIGNAL & TONE CW.
  4. "A" SUPPLY VOLTAGE = 13.2 V; NORMAL CURRENT DRAIN = 1.5 AMP.
  5. MEASUREMENTS TAKEN WITH 20,000.0/ VOLT METER, GRID VOLT. TAKEN WITH V.T.V.M.
- \* INDICATES A RESISTANCE OF LESS THAN 1 OHM.

### SETTING PUSH BUTTONS

Stations may be set up in any order. However, for convenience in remembering, it is suggested that stations be set up in frequency sequence.

**NOTE:** In metropolitan areas, it is recommended that the push buttons be set up in a shielded place where signals are weak, such as under a viaduct or in a steel-constructed building. In this way, accuracy of adjustment is assured.

1. Turn radio on and allow it to operate for fifteen minutes. Antenna should be fully extended.
2. Unlock push buttons by pulling them out.
3. Accurately tune in a station with manual tuning knob.
4. Lock one push button to that station by pushing firmly in.
5. Repeat above procedure for remaining push buttons.

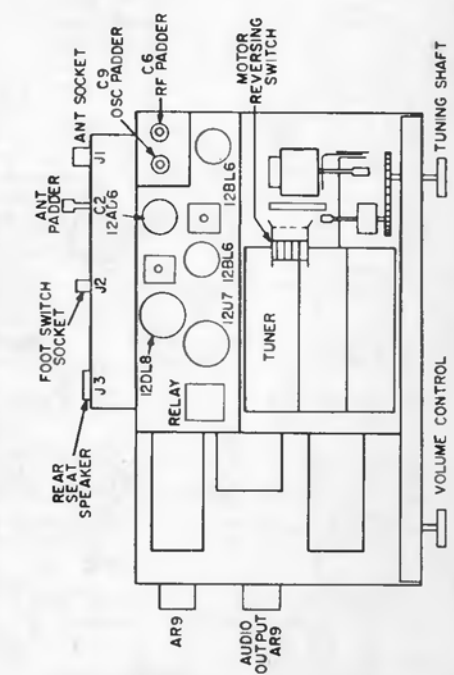

# PHILCO AUTO RADIO

MODEL M-5841

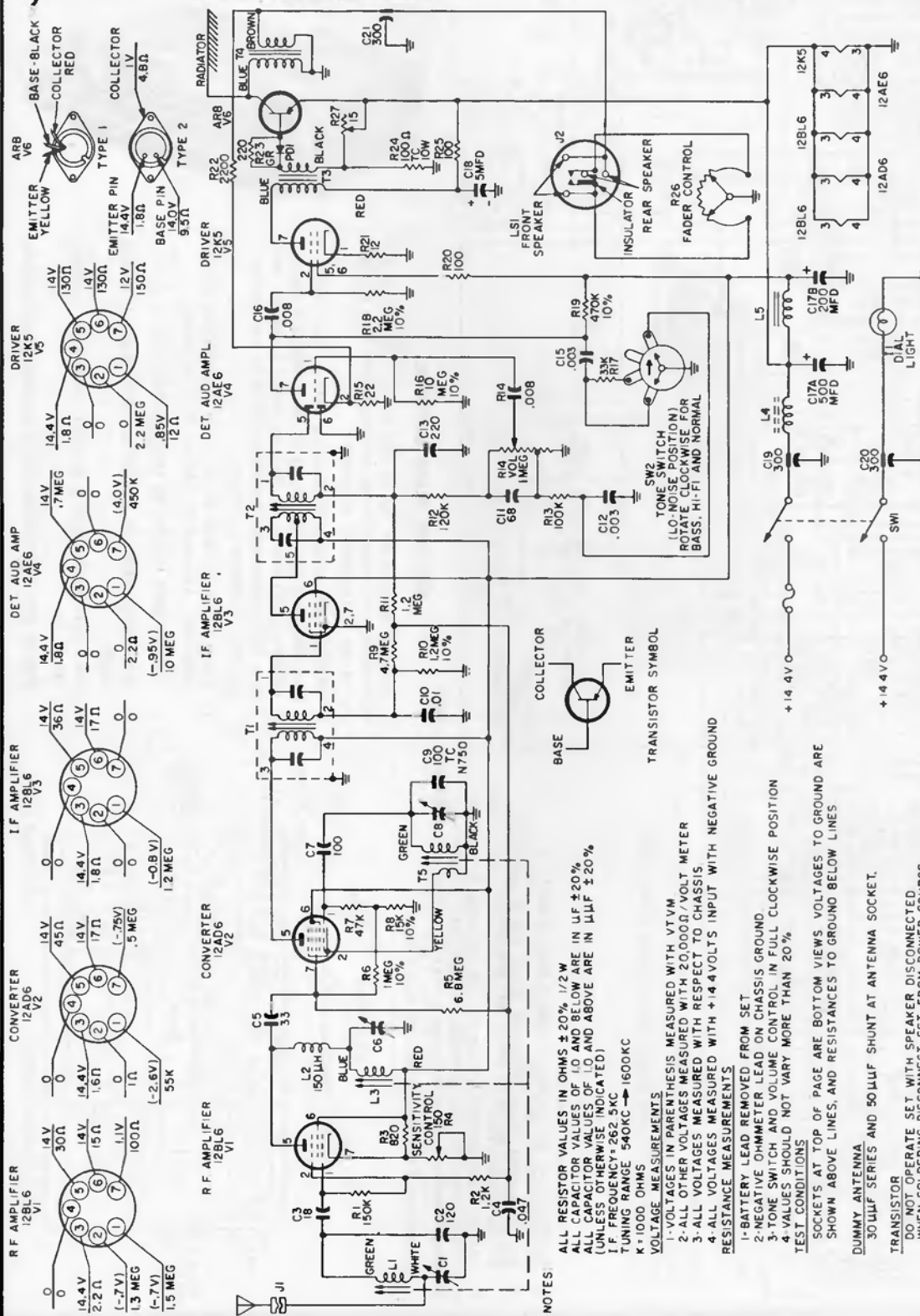

**IMPORTANT:** When connecting radio to "A" supply, either in car or on test bench, polarity must be observed. "A +" lead is positive, "A -" is chassis ground.

PHILCO AUTO RADIO MODEL M-5841

**NOTES:**  
 ALL RESISTOR VALUES IN OHMS ±20% 1/2 W.  
 ALL CAPACITOR VALUES OF 10 AND BELOW ARE IN UF ±20%.  
 ALL CAPACITOR VALUES OF 10 AND ABOVE ARE IN μUF ±20%.  
 (UNLESS OTHERWISE INDICATED)  
 I.F. FREQUENCY = 262.5 KC  
 TUNING RANGE = 540 KC → 1600 KC  
 K = 1000 OHMS

**VOLTAGE MEASUREMENTS**  
 1- VOLTAGES IN PARENTHESIS MEASURED WITH VTVM  
 2- ALL OTHER VOLTAGES MEASURED WITH 2000Ω/VOLT METER  
 3- ALL VOLTAGES MEASURED WITH RESPECT TO CHASSIS  
 4- ALL VOLTAGES MEASURED WITH +14.4 VOLTS INPUT WITH NEGATIVE GROUND

**RESISTANCE MEASUREMENTS**  
 1- BATTERY LEAD REMOVED FROM SET  
 2- NEGATIVE OHMMETER LEAD ON CHASSIS GROUND  
 3- TONE SWITCH AND VOLUME CONTROL IN FULL CLOCKWISE POSITION  
 4- VALUES SHOULD NOT VARY MORE THAN 20%

**TEST CONDITIONS**  
 SOCKETS AT TOP OF PAGE ARE BOTTOM VIEWS. VOLTAGES TO GROUND ARE SHOWN ABOVE LINES, AND RESISTANCES TO GROUND BELOW LINES.

DUMMY ANTENNA  
 30 μUF SERIES AND 50 μUF SHUNT AT ANTENNA SOCKET.

TRANSISTOR  
 DO NOT OPERATE SET WITH SPEAKER DISCONNECTED WHEN SOLDERING DISCONNECT SET FROM POWER SOURCE USE BATTERY OPERATED INSTRUMENT WHEN MAKING MEASUREMENTS

POWER INPUT 2.2 amp. at 14.4 volts, d.c.  
 AERIAL Vertical whip, fender mounting (30 μuf. series, 30 μuf. shunt)  
 INTERMEDIATE FREQUENCY 262.5 kc.



# RCA VICTOR

## HFP RECORD PLAYER Chassis RS-164B, Rec. Changer RP-205D-2

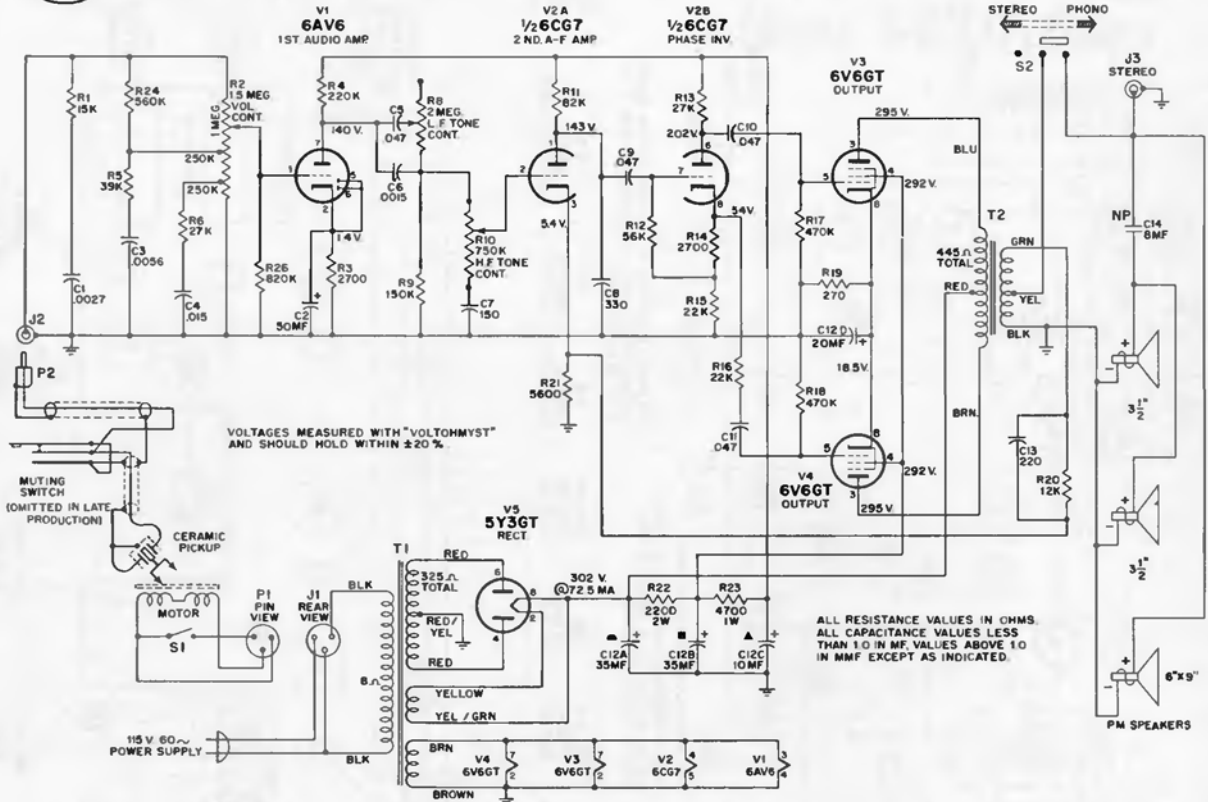

Model HFP  
The "Medley"  
Black, Mahogany,  
Oak or Walnut

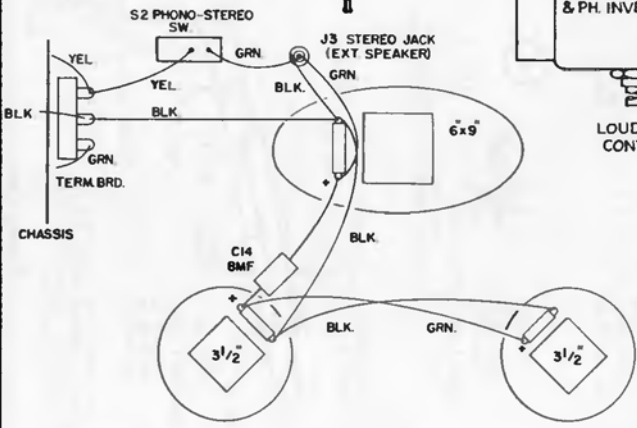
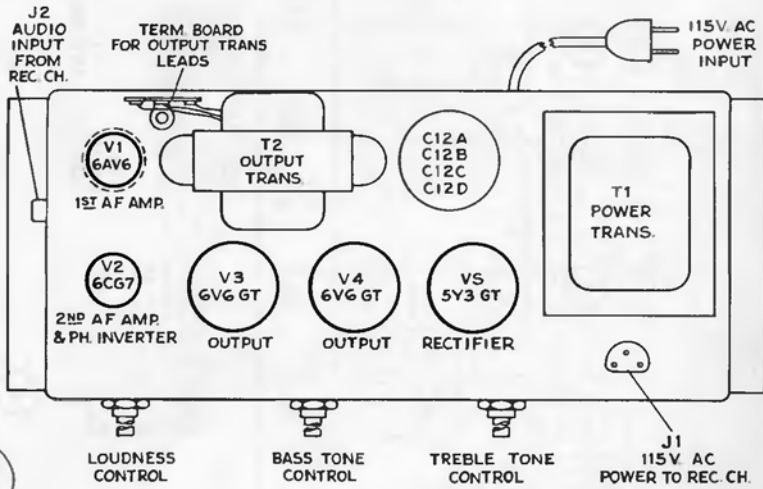

Speaker Connection Diagram—Model HFP

- POWER SUPPLY**  
115 volts, 60 cycles ..... 85 watts
- POWER OUTPUT** ... 10 watts undistorted, 12 watts maximum
- FREQUENCY RESPONSE** ..... 60 to 20,000 cycles
- LOUDSPEAKERS**  
One 6" x 9" PM "woofer" ..... 3.2 ohms @ 400 cy.  
Two 3 1/2" PM "tweeters" ..... 7.6 ohms each @ 6000 cy.



# MODEL 1-BT-58

Chassis No. RC-1156B

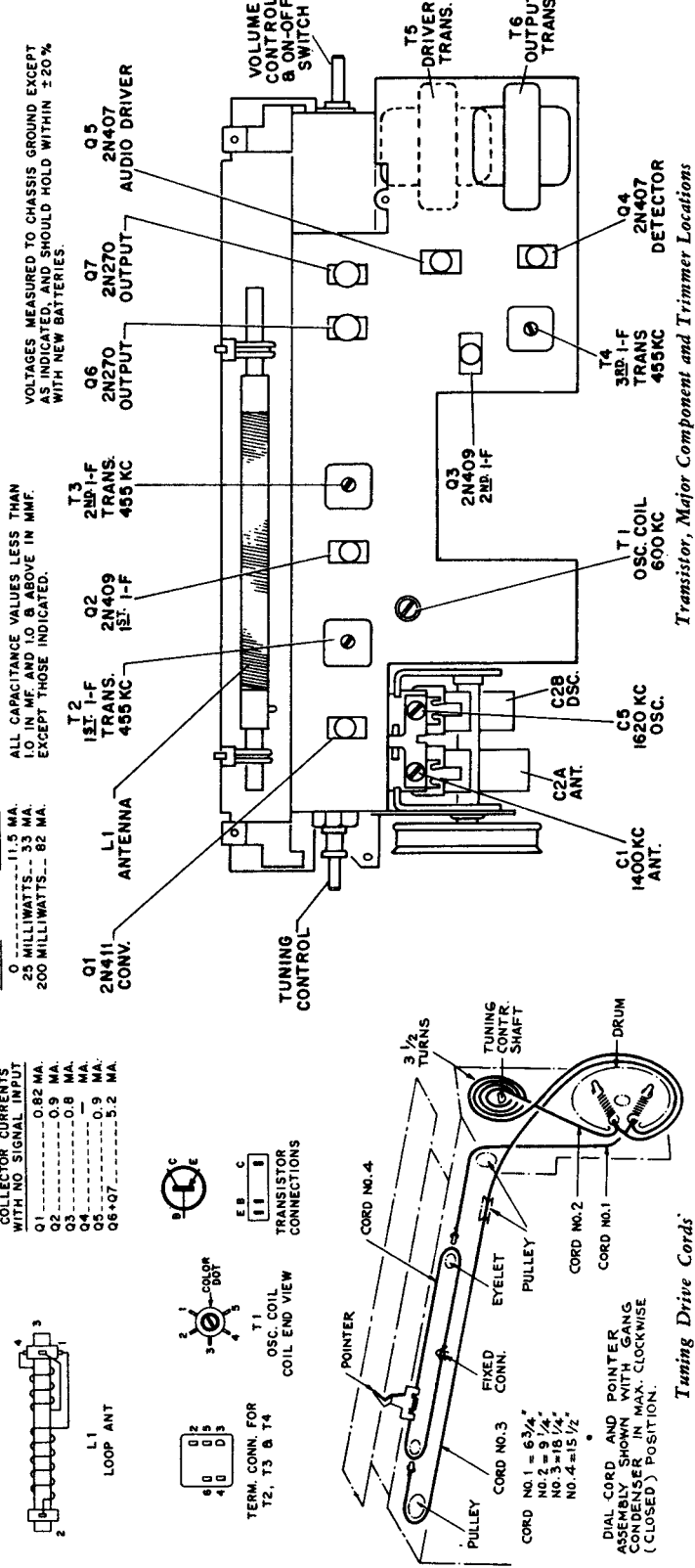
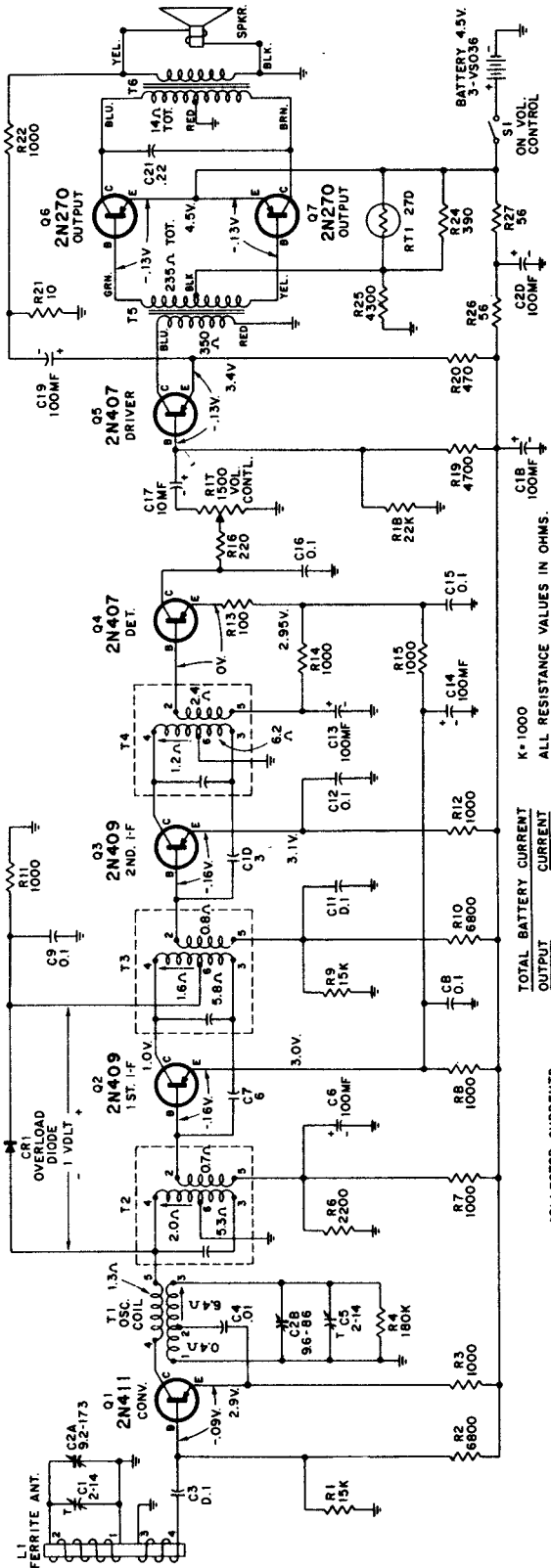

# RCA VICTOR

Chassis Nos. RC-1183, RC-1183A, RC-1183B

## MODEL 1-BX-5 SERIES MODEL 1-BX-6 SERIES MODEL 1-BX-7 SERIES

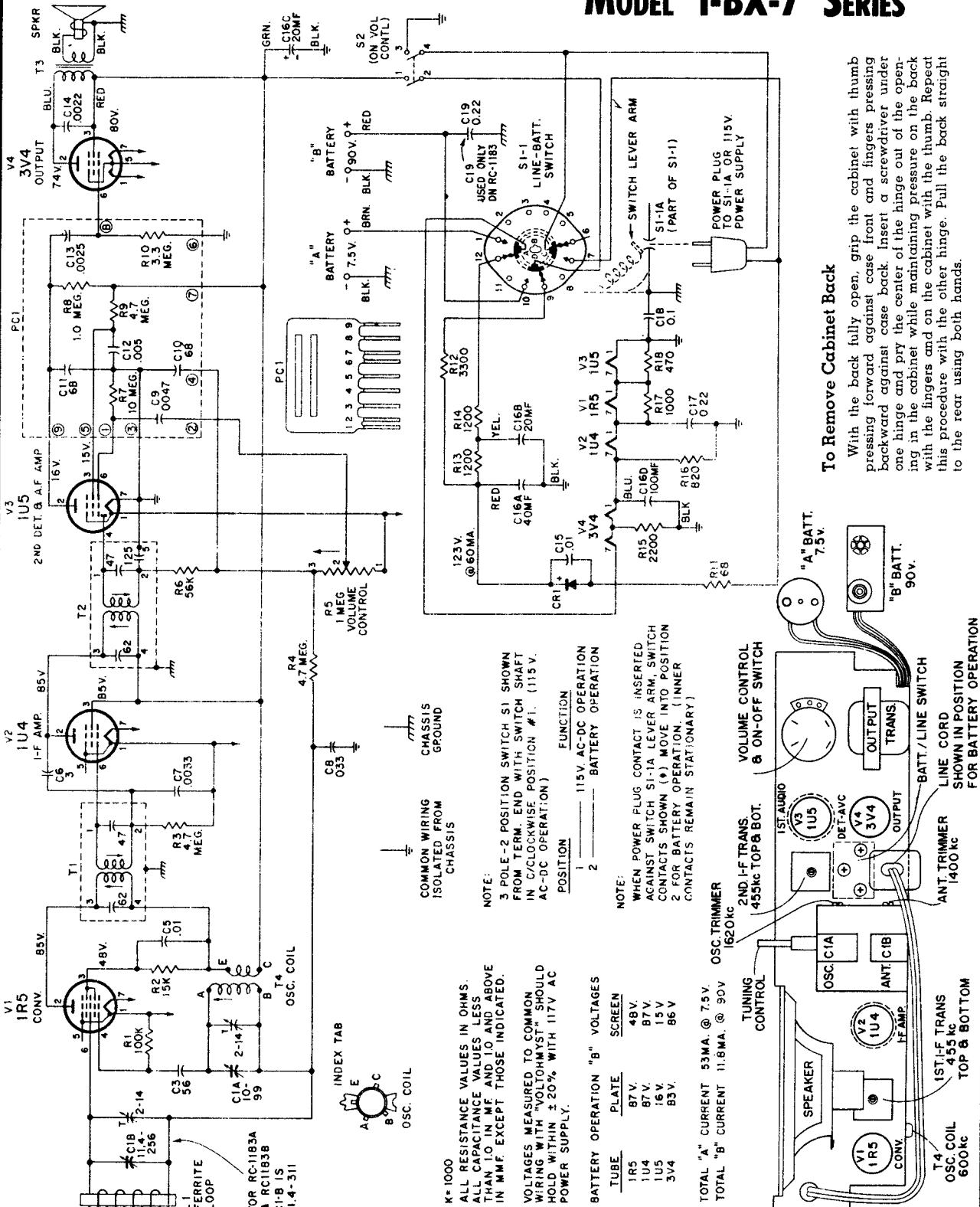

### To Remove Cabinet Back

With the back fully open, grip the cabinet with thumb pressing forward against case front and fingers pressing backward against case back. Insert a screwdriver under one hinge and pry the center of the hinge out of the opening in the cabinet while maintaining pressure on the back with the fingers and on the cabinet with the thumb. Repeat this procedure with the other hinge. Pull the back straight to the rear using both hands.

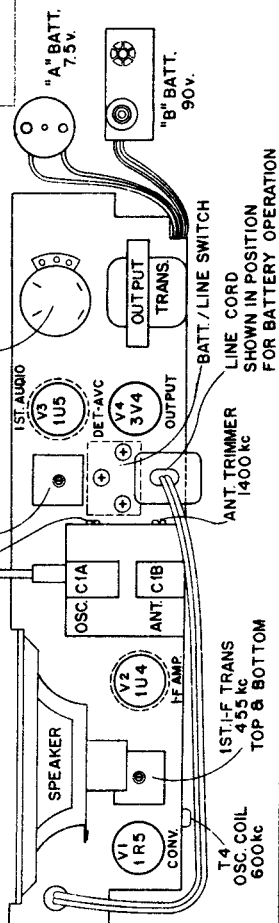

MOTOR ASSEMBLY

# RCA VICTOR

## MODEL HRD-2

Chassis No. RS-158J  
Record Player Mechanism No. RP-200-2

ILL. NO.	STOCK NO.	DESCRIPTION
1	102968	Wheel—Idler wheel
2	78509	Washer—Fibre washer (.015" thk. x 31/64" O.D. x 7/32" I.D.)
3	78652	Washer—"C" type retaining washer
4	102969	Plate—Idler plate assembly
5	78517	Link—Idler link
6	78515	Washer—Metal washer
7	78512	Spring—Idler spring
8	.....	Screw—Hold down plate mounting screw (#6-32)
9	102970	Plate—Hold down plate
10	78520	Spring—Shifter latch spring
11	78518	Arm—Pulley plate latch arm
12	78514	Grommet—Motor mounting grommet
13	78519	Spring—Pulley latch spring
14	78528	Washer—Speed pulley fibre washer
15	78525	Pulley—33 1/2 RPM pulley assembly
16	78526	Pulley—45 RPM pulley assembly
17	78527	Pulley—78 RPM pulley assembly
18	102972	Pulley—16 1/2 RPM pulley assembly
19	102974	Lever—Speed shift lever
20	78521	Lever—Latch arm lever
21	79967	Sleeve—Sleeve pulley for 50 cycle operation
21	78522	Sleeve—Sleeve pulley for 60 cycle operation
22	102973	Retainer—Pulley retainer "C" ring
23	102971	Plate—Speed pulley mounting plate (less pulleys)
	102541	Motor—4 Speed motor assembly complete.

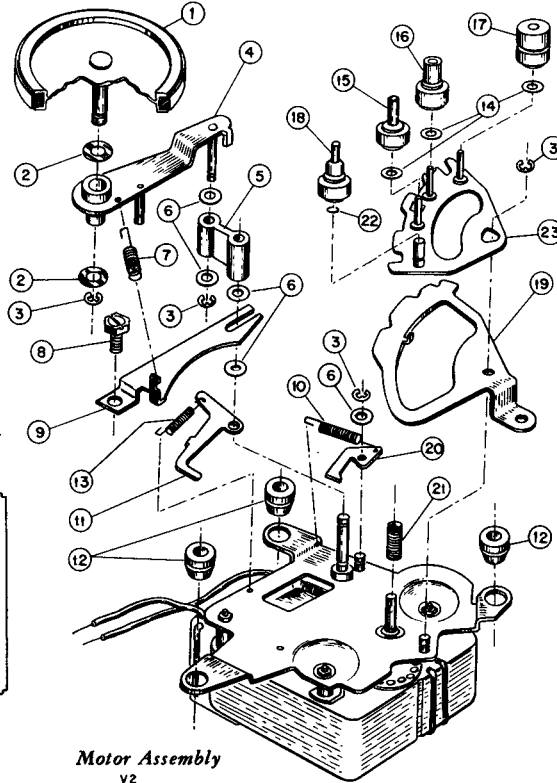

Motor Assembly

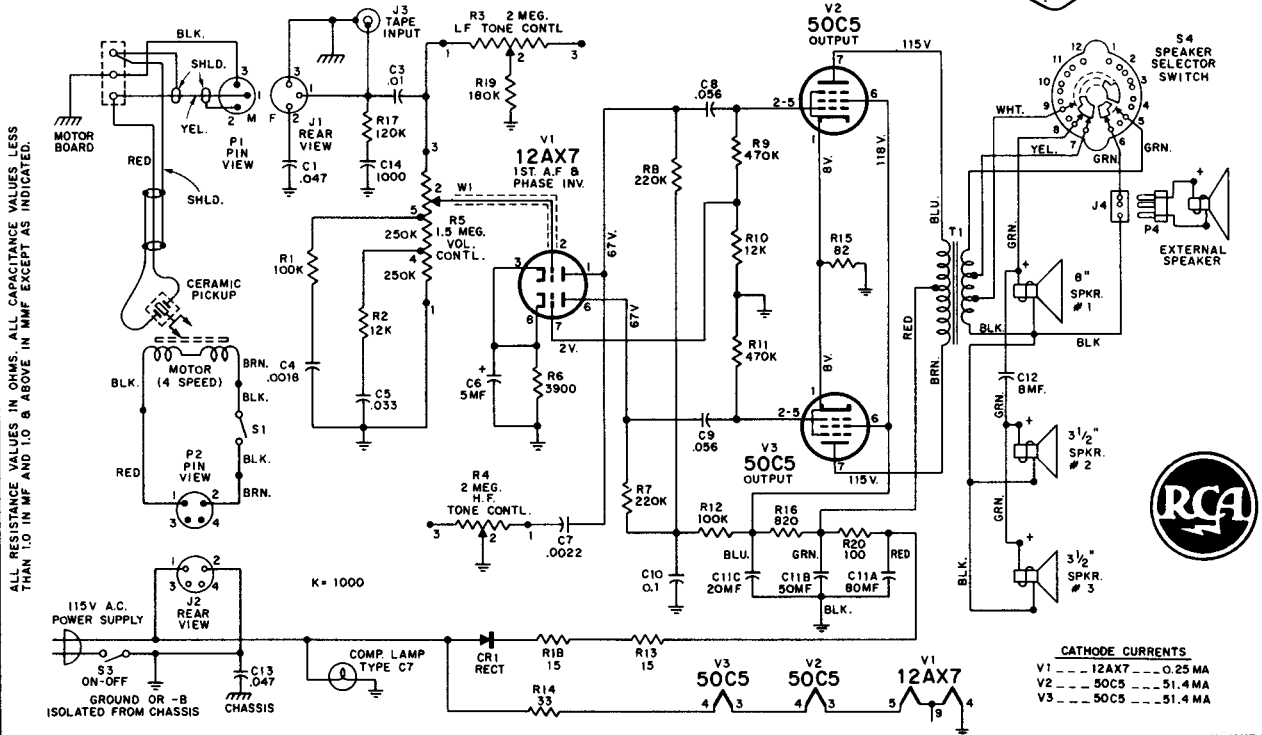
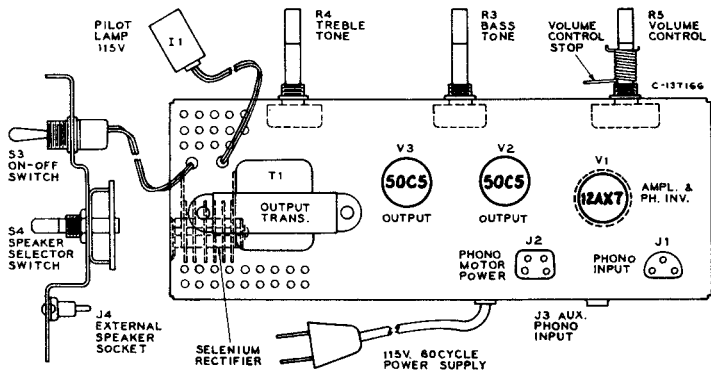

ALL RESISTANCE VALUES IN OHMS. ALL CAPACITANCE VALUES LESS THAN 1.0 IN MF AND 1.0 & ABOVE IN MMF EXCEPT AS INDICATED.



CATHODE CURRENTS

V1	12AX7	0.25 MA
V2	50C5	51.4 MA
V3	50C5	51.4 MA





RCA VICTOR

**8-X-5 SERIES, 8-X-6 SERIES  
MODEL 8-X-51**

**Chassis No. RC-1170, RC-1178**

8-C-5 Series and Model 8-C-51, using Chassis RC-1179, are like RC-1170, and 8-C-6 Series, Chassis RC-1179A, are like RC-1178, except of addition of timer with switch.

**Alignment Procedure**

Step	Connect the high side of test-oscillator to—	Tune test-osc. to—	Turn radio dial to—	Adjust the following for max. output
1	12BA6 I-F grid through .01 mfd. capacitor	455 kc	Quiet-point 1,600 kc end of dial	T2 (top) 2nd I-F trans.
2	Stator of C1-B through .01 mfd.			T1 (top and bottom) 1st I-F trans.
3		1,620 kc	Gang fully open	osc. trimmer C1-A
4	Short wire placed near loop to radiate signal	1,400 kc	1,400 kc signal	ant. trimmer C1-B
5		600 kc	600 kc signal	osc. coil T-4 (rock gang)
6	Repeat steps 3, 4, and 5			

(RC-1178 ONLY)

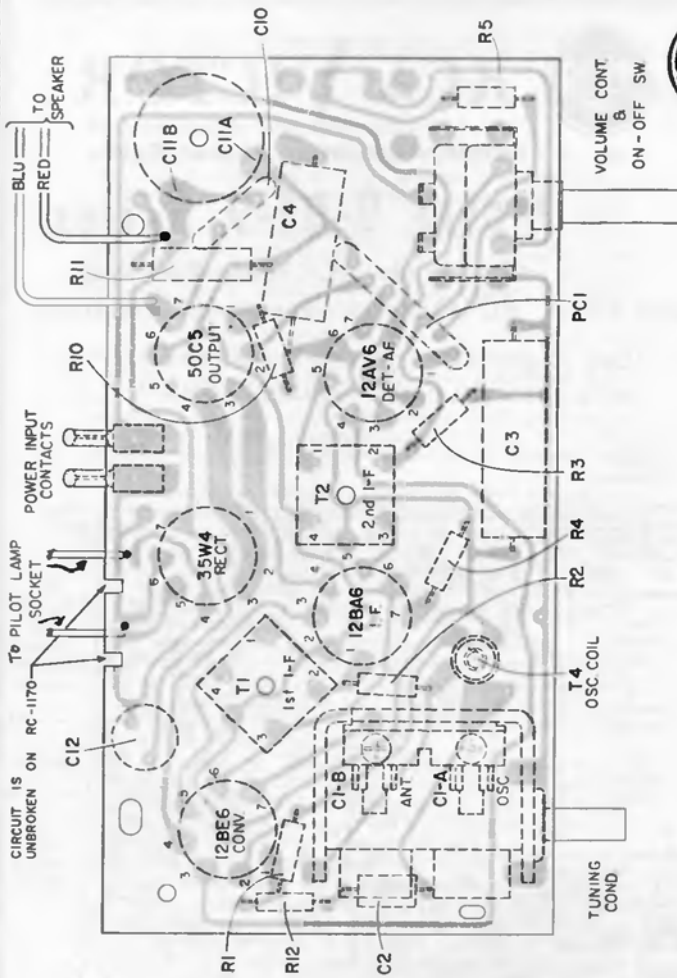

**Chassis Wiring and Components — View from Wiring Side**

The assembly represented above is viewed from the wiring side of the board. The printed wiring, on the near side of the board, is presented in "phantom" view superimposed on the component layout of the reverse side.

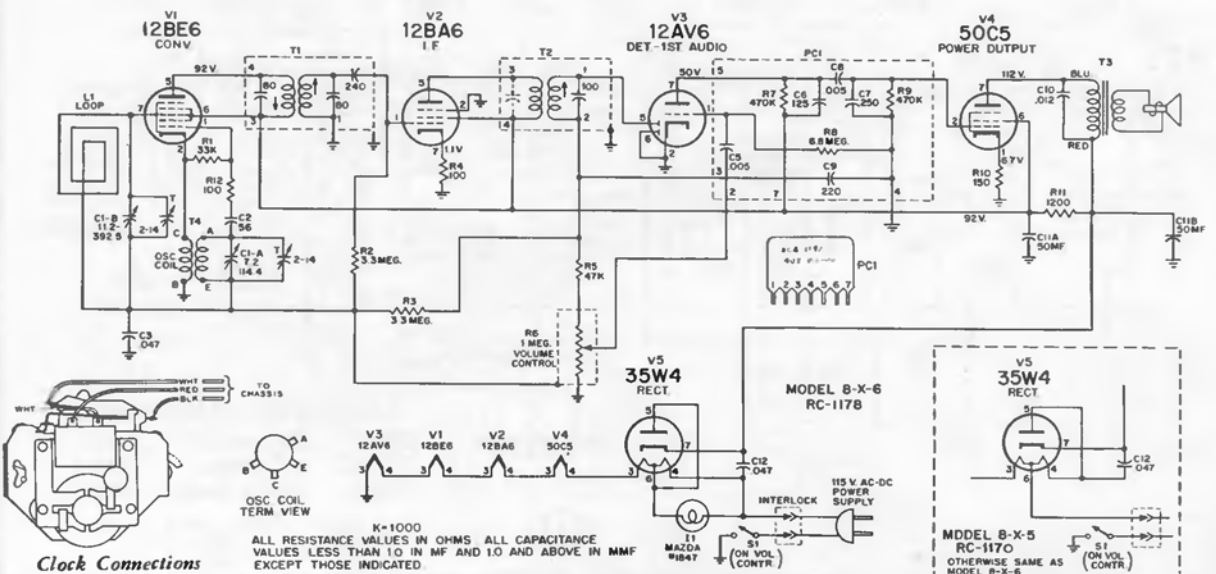

**Clock Connections**

ALL RESISTANCE VALUES IN OHMS ALL CAPACITANCE VALUES LESS THAN 10 IN MF AND 10 AND ABOVE IN MMF EXCEPT THOSE INDICATED

MODEL 8-X-5 RC-1170  
OTHERWISE SAME AS MODEL 8-X-6



# RCA VICTOR

Battery-Operated Pocket Radio

## MODEL 9-BT-9 Series

Chassis No. RC-1164A, RC-1164B

Model 8BT9, RC-1164, is practically identical.

(See pages 147 and 148 for additional service hints and alignment facts.)

Model 9-BT-9 Series The "Transistor Six"

Printed Circuit Board Wiring and Components  
View from Wiring Side

Circuit Board No. 961919-1  
Chassis No. RC-1164A

The assembly represented above is viewed from the wiring side of the board.

The printed wiring, on the near side of the board, is presented in "phantom" view superimposed on the component layout of the reverse side.

### CRITICAL LEAD DRESS

Dress leads and components at gang so as not to interfere with rotor plates.

Dress lead from antenna to gang ant. terminal away from metal parts as far as practicable.

Check for possible solder shorts to volume control knob from printed circuit wiring.

Antenna terminal of gang must be bent to insure clearance to output transformer.

Dress "B-" lead from ON-OFF switch to battery under positive (+) lead of C16.

Dress antenna rod to clear end of case and such that antenna terminal does not interfere with closing of case back.

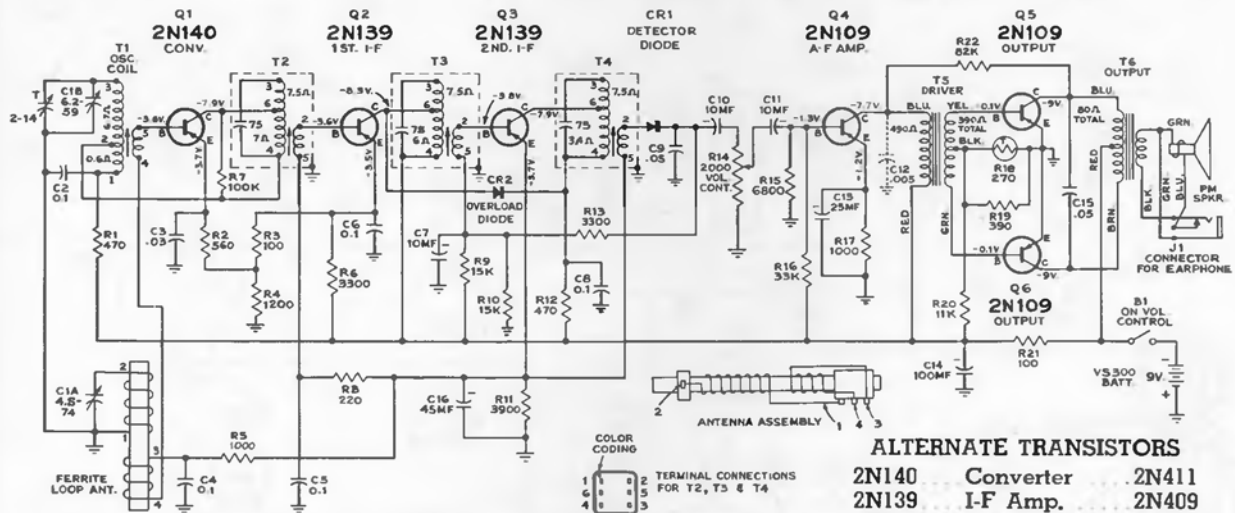
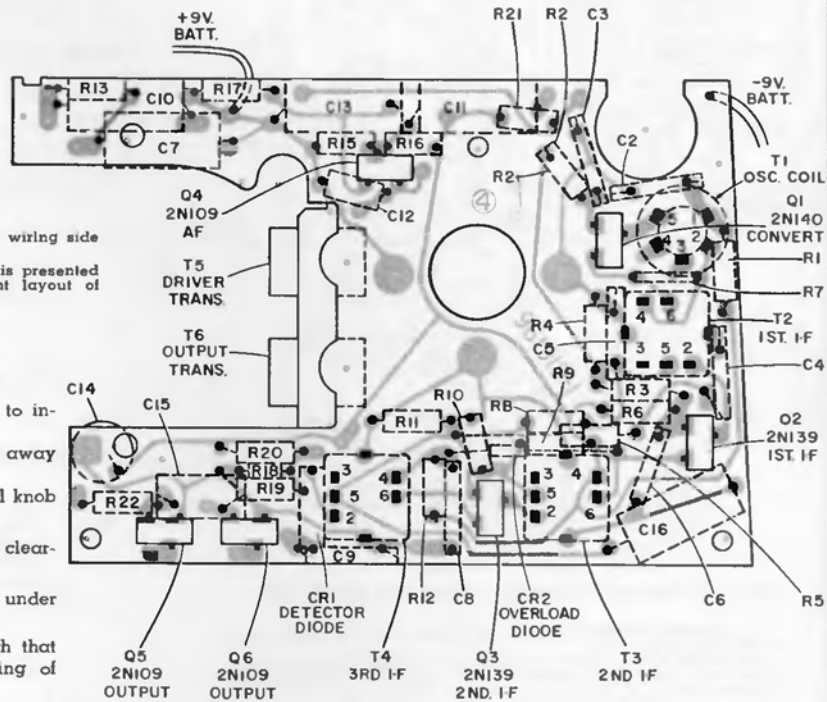

**ALTERNATE TRANSISTORS**

2N140	Converter	2N411
2N139	I-F Amp.	2N409
2N109	Audio Amp.	2N407

VOLTAGES MEASURED WITH "VOLTHOMYST" SHOULD HOLD WITHIN ±20% WITH NEW BATTERY. K=1000. ALL RESISTANCE VALUES IN OHMS. ALL CAPACITANCE VALUES LESS THAN 1.0 IN MF AND 1.0 & ABOVE IN MMF EXCEPT THOSE INDICATED.



**BATTERY CURRENT**  
NO SIGNAL ----- 8 MA  
15 MW OUTPUT ----- 13 MA.

RCA Victor Model 9-BT-9 Series, Chassis RC-1164A, -B, Continued

SERVICE HINTS

Recommended Test Procedure

Use signal tracing or signal injection as basic test procedure in conjunction with voltage measurements.

Make stage-by-stage check by injecting signal from signal generator and checking with a high-gain oscilloscope (at least .03 volts/inch). Oscillator action must be stopped in order to measure RF signal at converter base since oscillator signal also appears at this point. Oscillator action can be stopped by touching a finger to oscillator section of the tuning condenser.

NOTE: All transformers are step-down type and will show voltage loss from primary to secondary.

Extreme care should be used to avoid accidental shorting of transistor elements to circuit ground. This is especially true of the output transistors; if the junction of R18-R19-R20 should be accidentally grounded for a few seconds, the output transistors would be permanently damaged.

It is possible to damage a transistor when testing circuit continuity. Since a transistor needs only low voltage applied to its terminals for conduction, testing continuity of a circuit which includes a transistor can result in misleading continuity indications. To avoid transistor damage and misleading continuity indications, remove the transistor from the chassis before making continuity tests of its circuit.

1. The first thing to check when the receiver is inoperative, is the battery. With the receiver turned on, a new battery should show 9 volts although the receiver can be expected to operate on any battery which checks between 6 volts and 9 volts.
2. To check for a circuit defect which would cause excessive battery drain, an overall current measurement and supplementary voltage measurements should be made. For reasons explained above, continuity measurements can be misleading.
3. Signal tracing by injection of a signal from a signal generator is done on transistor radios in exactly the same manner as with conventional vacuum tube radios. The signal generator should be connected (as in past practice) in series with a capacitor to avoid shorting out bias voltages. With the transistors used in this receiver, the BASE is the signal input terminal (corresponding to signal grid of tubes), the COLLECTOR is the signal output terminal (corresponding to plate of tubes), and the EMITTER is the common terminal (corresponding to cathode of tubes).
4. The output of this receiver is of the "Class B" type. It should be noted that in "Class B" output the battery

current increases noticeably with increased signal input. Refer to the schematic diagram for current specifications.

5. Application of a signal from a signal generator to the input (B) of Q1 will stop oscillator action (R-F signal can not be injected at this point although 455 kc I-F signal can be injected).
6. Measurement of oscillator signal strength with an oscilloscope at the input of Q1 (base contact) will give an indication of oscillator performance. Voltage should be 0.20 to 0.70 volts peak-to-peak.
7. D-C measurements should be made only with a sensitive voltmeter, such as an RCA VoltOhmst®.
8. Interchanging transistors in the I-F stages may necessitate realignment.
9. The transistors and the printed wiring board can be readily damaged by excessive heat. When soldering on the printed wiring board, use a soldering iron which is both HOT and CLEAN. The soldering operation can then be completed quickly with a minimum of heat radiation to components.

ALIGNMENT PROCEDURE

Test Oscillator—For all alignment operations, connect the low side of the test oscillator to the "common positive" wiring and keep the oscillator output as low as possible to avoid AVC action.

Step	Connect High Side of Sig. Gen. to —	Sig. Gen. Output	Dial Pointer Setting	Adjust for Max. Output
1	#2 terminal of ant. assembly L1	455 kc	Quiet point near 1600 kc	T4 3rd I-F T3 2nd I-F T2 1st I-F
2		Repeat Step 1		
3	Short wire placed near antenna for radiated signal	1400 kc	1400 kc rock gang	trimmer* C1-B (osc.)
4		600 kc	600 kc rock gang	T1 osc. coil
5		Repeat Steps 3 and 4		

\* Oscillator trimmer is located on bottom of gang.

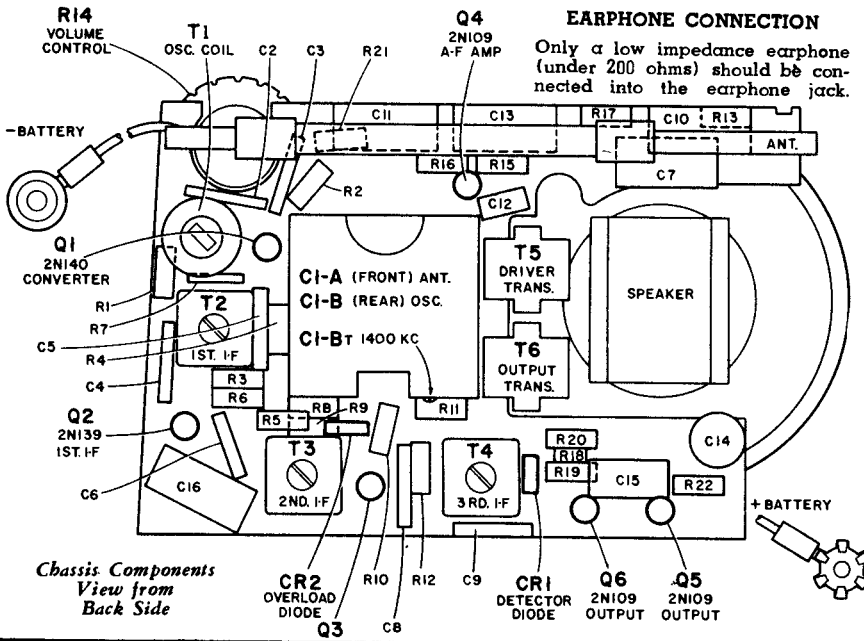

Production Changes

1. R4 was 1000 ohms. R5 was 220 ohms.
2. C9 was .03 mf. C12 (.005 mf.) removed—it was connected from collector of Q4 to gnd. C16 (45 mf.) was a wire-in type of capacitor in early production. It may be either a wire-in type or upright type in late production.

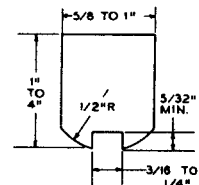

MATERIAL—STEEL OR BRASS THICKNESS OF 25¢ COIN.

Tool Required for Removal of Chassis Mounting Nut

2N139  
2ND. I-F

## RCA Victor Model 9-BT-9 Series, Chassis RC-1164A, -B, Continued

## SERVICE PROBLEMS AND REMEDIES

**Distorted Only On Weak Stations Or Only On Strong Stations**

When distortion is present and varies with the strength of the station signals, it indicates an abnormal condition in the circuit of those transistors whose bias is AGC controlled.

Distortion only on weak stations is most often due to unsatisfactory operation of the detector. The diode should have a slight initial forward bias. Check for presence of this bias voltage, check to see that polarity does not reverse with signal and that AGC voltage with signal is of proper polarity (base to emitter voltage should decrease with increase of signal).

Distortion on strong stations indicates that the transistors are being driven to cutoff by a strong AGC voltage. An overload diode is used to reduce the gain of an IF circuit only on strong signals. Check terminal voltages and the overload diode. Transistor radios will not handle large variations of signal as well as vacuum tube radios, and it may be that on excessively strong signals the best solution is to turn the radio so that the antenna will pick up less signal.

**Regeneration**

An IF transistor having exceptionally high gain may cause regeneration on weak signals. A possible correction for this difficulty is to interchange the two IF transistors—realignment is advisable after any change of transistors in the IF circuit.

If a type 2N140 transistor is used in place of a type 2N139 transistor, regeneration may occur. Check for use of correct type of transistor.

Two specific types of regenerative squeal have been found in the Transistor Six. The first type in which the audible sound can be controlled by the volume control has had several causes which were as follows:

1. High internal battery resistance. A new battery corrects the trouble.
2. High resistance riveted connections at battery leads on printed board. This trouble can be overcome by soldering the rivets to the printed wiring.
3. High resistance connections at chassis mounting spacer. This condition is evidenced by a change in the frequency and intensity of the squeal when the tuning condenser mounting screws are first loosened and then tightened. The spacer and the mounting screws are in the tuning condenser "ground" circuit and electrolytic action between the copper wiring and the die-cast zinc spacer results in corrosion and high resistance joints. A 3-point wire jumper should be soldered between the three copper areas at the tuning condenser mounting screws. The spacers now being used are copper plated and can be soldered to the wiring.
4. Stripped tuning condenser mounting screw. The third tuning condenser mounting screw is also used as part of the tuning condenser "ground" circuit. The screw must be long enough to hold securely in the condenser and yet not long enough to touch the tuning condenser plates.
5. Rosin joint at tuning condenser mounting screw. The third tuning condenser mounting screw mentioned above is soldered to the printed wiring. Some cases of poor soldering have resulted in rosin joints.
6. The mounting lugs of IF transformers T3 and T4 are used for ground interconnections. Loose rivets can result in intermittent regeneration. Solder a jumper wire between the two mounting lugs of each can.

**No Signal**

In cases of "no signal," the first step is to check battery voltage with set turned on. New batteries are 9 volts, but transistor radios will operate on batteries as low as 6 volts. If the battery is O.K., check terminal voltages. There can be short-circuits in transistor radios just as in any other radio. One significant difference is that in a transistor radio, there is insufficient power to burn a resistor.

Transistors have no filaments to burn out, but lead wires can be broken. Battery leads and phone jack leads are the most likely source of such trouble. Transistors themselves should be the last items suspected.

**Weak RF/IF Signal**

Transistor life in normal service has no known limit; service deterioration is so negligible as to be dismissed without further thought.

In all cases of RF/IF low sensitivity, first check terminal voltages. Although voltages may vary widely without greatly affecting stage gain, the voltages should all have the same proportion of variation. The bias voltages are the most difficult to measure but must not be neglected. A transistor having a normal "forward" bias of 0.15 volt will have a slight decrease in gain when operating with a bias of 0.12 volt but may have a great decrease in gain when operated with a bias of 0.10 volt. If a large voltage discrepancy is found it will be necessary to remove transistors before making resistance measurements in localizing the trouble.

Where a transistor stage shows low gain, shunt each bypass capacitor in that stage with another capacitor to detect open capacitors.

Alignment should be checked in all cases of low RF/IF sensitivity. There is only one core to each IF transformer but in some cases two peaks may be reached, one peak being higher than the other. If a transformer can not be peaked, it may have to be replaced—first check transformer terminal connections. The following are alignment suggestions:

1. IF transformer will not peak at 455KC—may be either defect in transformer or defective transistor (IF or converter)—try replacing transistor before changing transformer. An open bypass capacitor in the circuit of that transformer could give an unsatisfactory peaking condition.
2. IF transformers may be peaked incorrectly—maximum gain is obtained when cores are peaked at the "farthest in" peak.

Other possibilities of low RF/IF sensitivity are as follows:

1. Incorrect transistor—if type 2N139 is used in place of specified type 2N140, conversion gain will be down and oscillator section may fail to operate when battery voltage is down slightly.
2. Resistor value change in oscillator or converter stage—measure oscillator a.c. voltage at Q1 base (should be 0.20 to 0.70 volts p-p)—measure d.c. voltages—remove transistors and check resistors in converter circuit; if transistors are soldered in, unsolder one end of suspected resistor and measure without removing transistors.
3. Detector diode reversed—output is down slightly. Check by noting polarity of AGC voltage at the diode source. AGC line voltage at the diode will become more positive (or less negative) in respect to circuit ground with signal increase.

**Audio Distortion**

One type of audio distortion is regeneration due to low capacity filters and/or high resistance joints.

Because the output transistors are in a "Class B," circuit, even a small change in bias may result in distortion. The no-signal emitter or collector current of each of the output transistors should be 1.5 to 2 ma with a new battery. A bias voltage of  $-0.1$  v. is required at that current drain.

Negative feedback is used to reduce distortion, the feedback resistor R22 is 82K. If the resistor is connected to the wrong output collector, the distortion would be increased instead of decreased. This tells us that the YEL. and GRN. leads of the driver transformer must not be interchanged and neither should the BLUE and RED leads be reversed. Some transformers had incorrect color coding.

A simple case of low output and distortion has resulted from one pin of one output transistor being bent at right angles and not in its socket; the other two pins held the transistor in place.

In factory production, selected pairs of transistors are used for Class "B" output. Mismatched transistors will result in some distortion, this may or may not be noticeable during listening. Transistors may be matched by injecting an audio signal at the volume control and measuring the audio signal from each output collector to "ground." Matched transistors will give matched output signal.

# RCA VICTOR

## MODEL 8-BX-5 Series

Chassis No. RC-1149

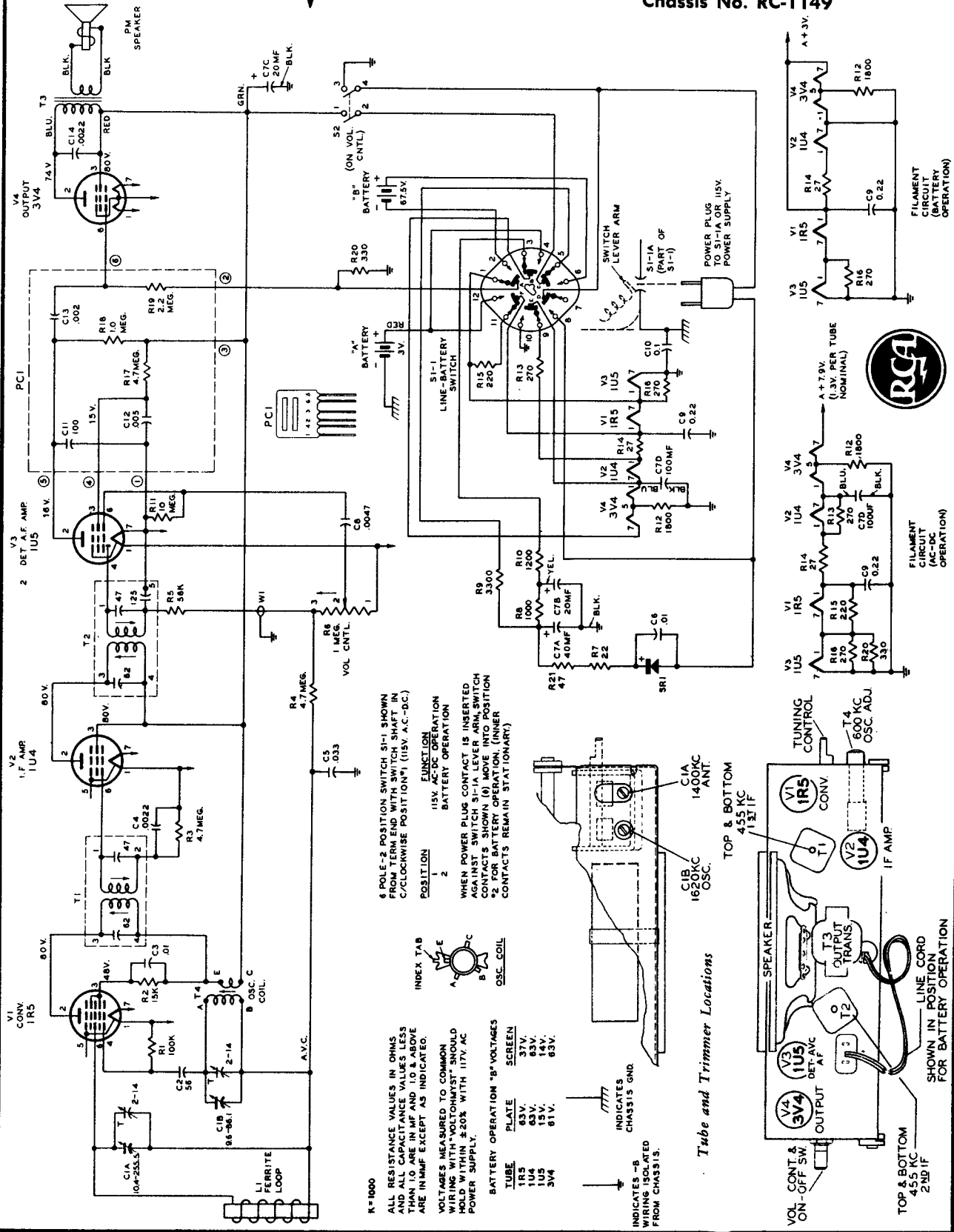

6 POLE-2 POSITION SWITCH S1-1 SHOWN FROM TERM END WITH SWITCH SHAFT IN C/CLOCKWISE POSITION\* (115V. A.C.-D.C.)

POSITION 1 115V. A.C.-D.C. OPERATION  
POSITION 2 BATTERY OPERATION

FUNCTION INDEX TAB

WHEN POWER PLUG CONTACT IS INSERTED AGAINST SWITCH S1-1A LEVER ARM, SWITCH CONTACTS SHOWN (B) MOVE INTO POSITION SHOWN (A) AND OPERATION NUMBER CONTACTS REMAIN STATIONARY (A).

ALL RESISTANCE VALUES IN OHMS UNLESS OTHERWISE SPECIFIED. ALL CAPACITANCE VALUES LESS THAN 100PF ARE IN P.F. EXCEPT AS INDICATED.

VOLTAGES MEASURED TO COMMON HOLD WITH "VOLTHOMYST" SHOULD HOLD WITHIN ±20% WITH 117V. AC POWER SUPPLY.

BATTERY OPERATION "B" VOLTAGES

TUBE	PLATE	SCREEN
1R5	83V.	37V.
1U5	83V.	81V.
3V4	81V.	83V.

INDICATES -B WIRING ISOLATED FROM CHASSIS.

INDICATES CHASSIS GND.

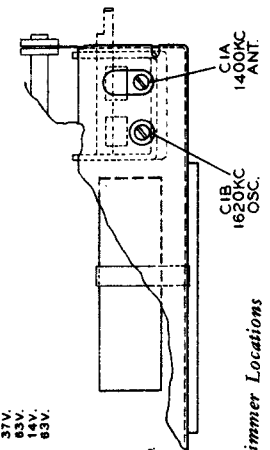

Tube and Trimmer Locations

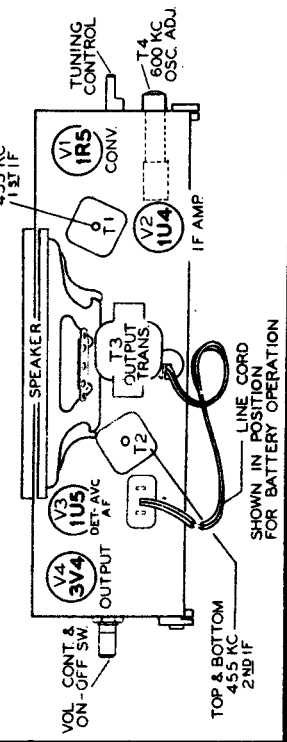

# RCA VICTOR

**MODEL 8-BX-6 SERIES,  
MODEL 8-BX-7 SERIES**

Chassis Nos. RC-1161, RC-1161A

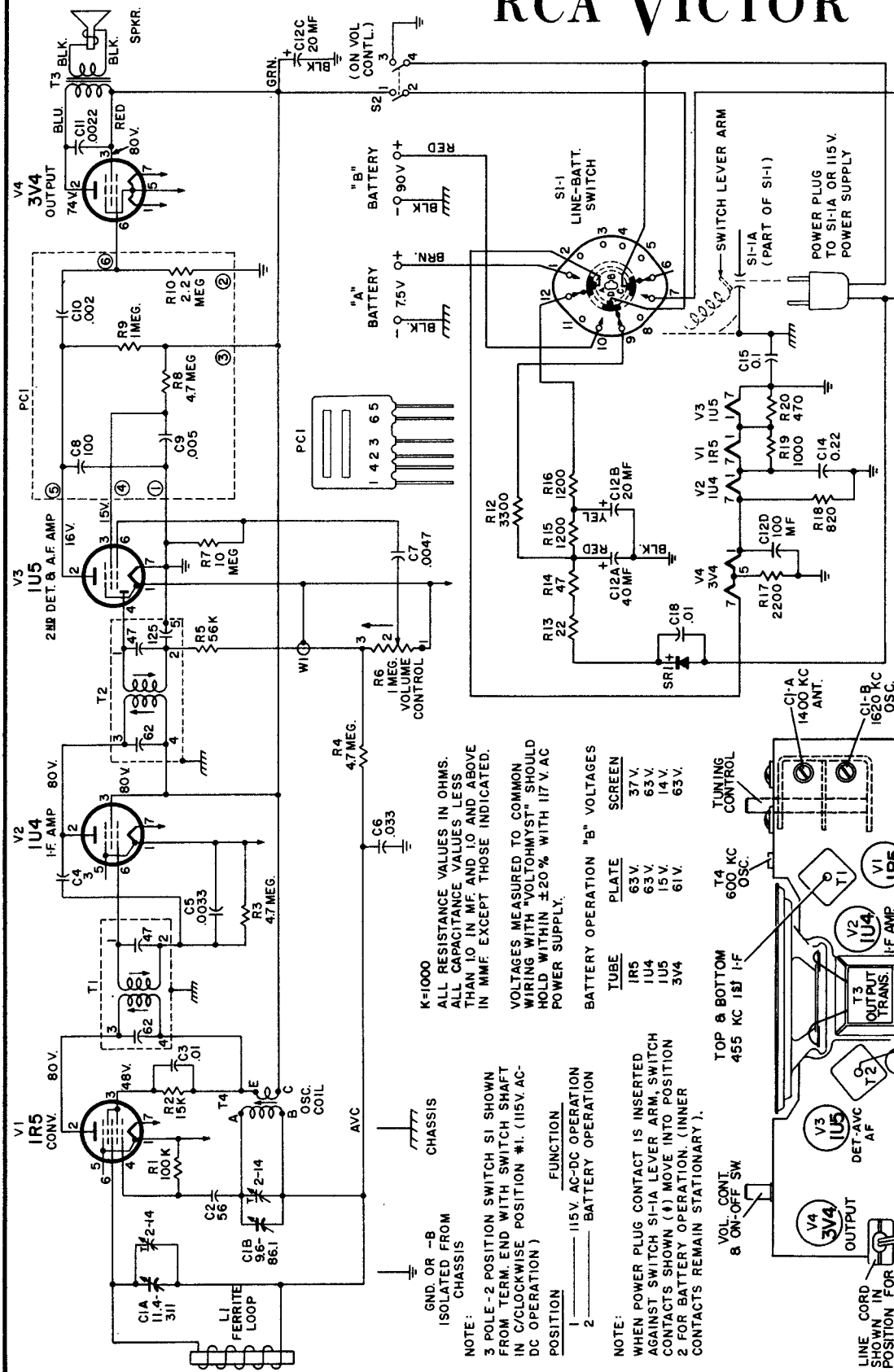
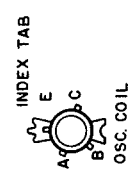

K=1000  
ALL RESISTANCE VALUES IN OHMS.  
ALL CAPACITANCE VALUES LESS  
THAN 10 IN MF AND 10 AND ABOVE  
IN MMF. EXCEPT THOSE INDICATED.

VOLTAGES MEASURED TO COMMON  
WIRING WITH "VOLTHOMYST" SHOULD  
HOLD WITHIN ±20% WITH 117 V AC  
POWER SUPPLY.

BATTERY OPERATION "B" VOLTAGES

TUBE	PLATE	SCREEN
IR5	63V	37V
IU4	63V	63V
IU5	15V	14V
3V4	61V	63V

NOTE:  
3 POLE-2 POSITION SWITCH S1 SHOWN  
FROM TERM. END WITH SWITCH SHAFT  
IN C/CLOCKWISE POSITION #1. (115V. AC-  
DC OPERATION)

POSITION \_\_\_\_\_ FUNCTION  
1 \_\_\_\_\_ 115V. AC-DC OPERATION  
2 \_\_\_\_\_ BATTERY OPERATION

NOTE:  
WHEN POWER PLUG CONTACT IS INSERTED  
AGAINST SWITCH S1-1A LEVER ARM, SWITCH  
CONTACTS SHOWN (#) MOVE INTO POSITION  
2 FOR BATTERY OPERATION. (INNER  
CONTACTS REMAIN STATIONARY).

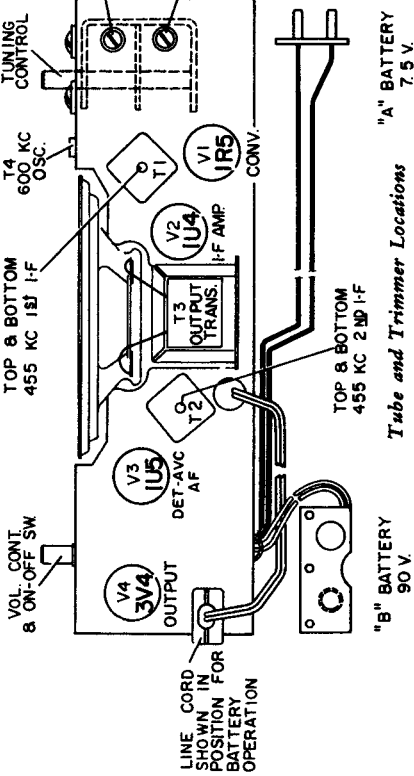

# RCA VICTOR

## MODEL 8-HF-45P

Chassis No. RS-159B

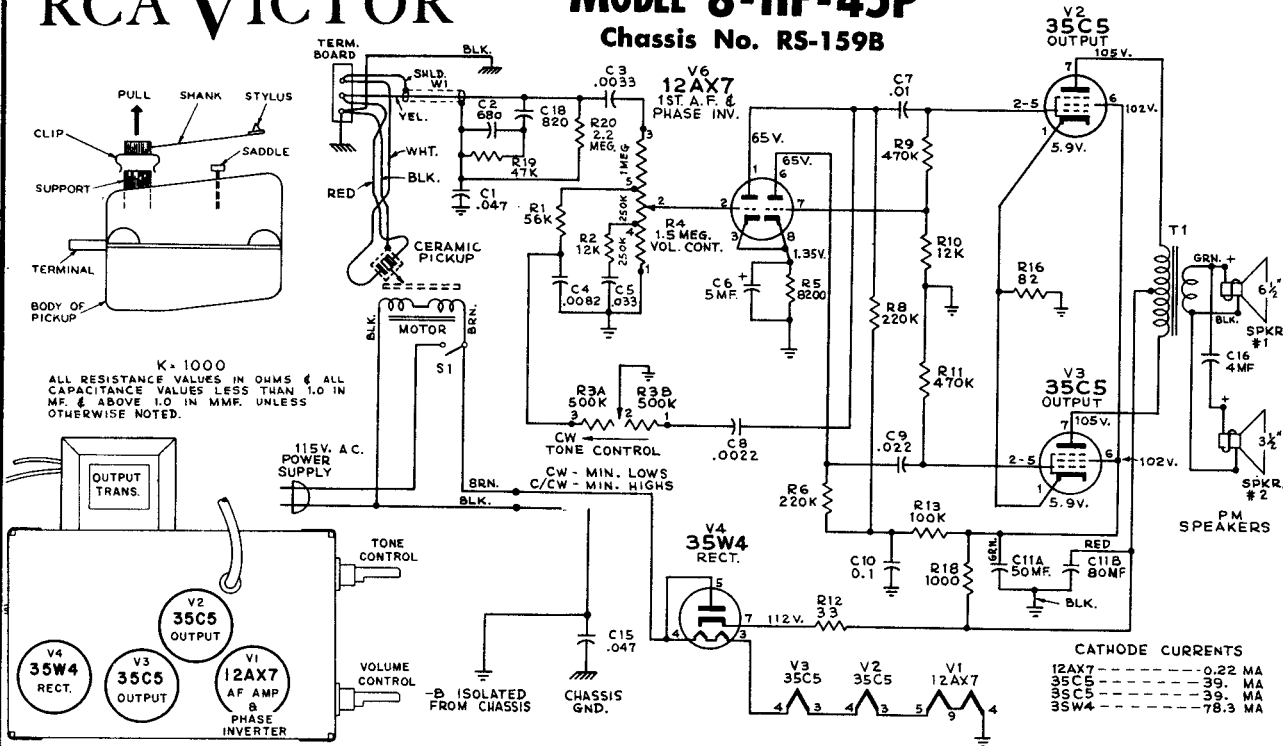

# RCA VICTOR

## MODELS SHF-6, SHF-7

Chassis Nos. RS-164, RS-164A

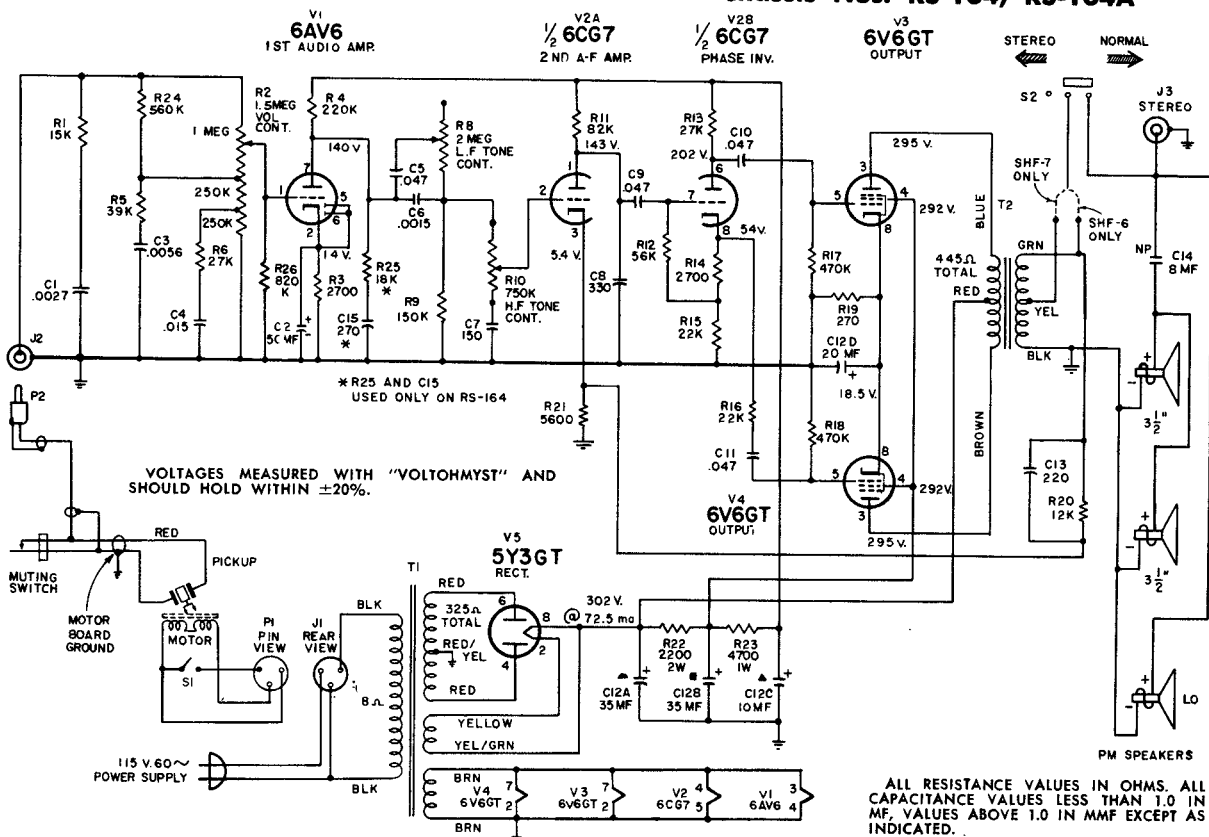

# RCA VICTOR

## 6-EY-3A, 6-EY-3B, 6-EY-3C

Chassis Nos. RS-152A, RS-152B, RS-152D, RS-152E

Chassis No. RS-152B

Same as shown for RS-152A  
except C2 is .0047 mf

Chassis No. RS-152E

V1 (A.F. Ampl.) is type 6AV6

R2 is 10 megohm

R9 is 390K

C7 (470 mmf) is added

otherwise same as shown

for Chassis No. RS-152A

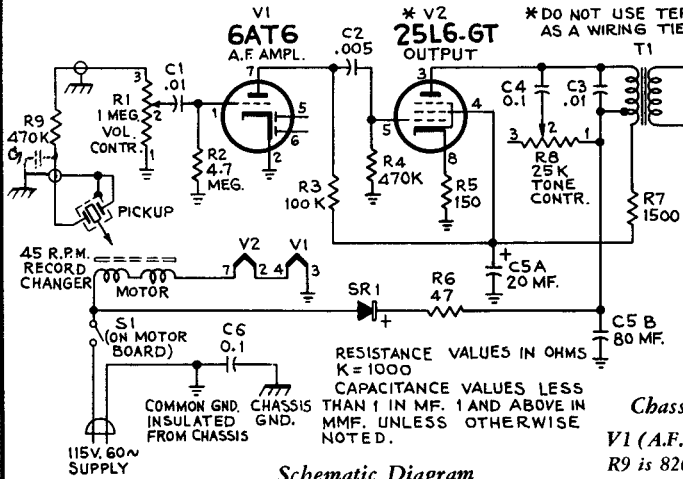

Schematic Diagram  
Chassis No. RS-152A

Chassis No. RS-152D

V1 (A.F. Ampl.) is type 6AV6

R9 is 820K

C2 is .0047

otherwise same as shown for Chassis No. RS-152A

RESISTANCE VALUES IN OHMS  
K = 1000  
CAPACITANCE VALUES LESS  
THAN 1 IN MF. 1 AND ABOVE IN  
MMF. UNLESS OTHERWISE  
NOTED.

## MODELS 9-ES-5H, 9-ES-5JE

Chassis No. RS-170B

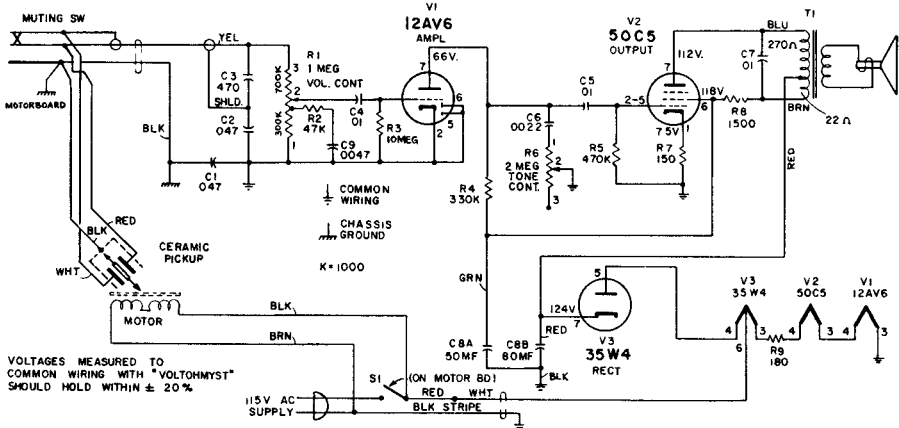
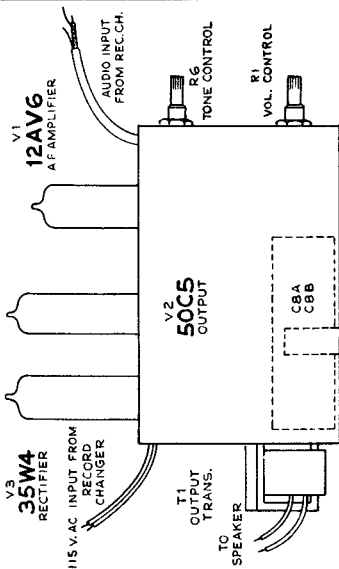

VOLTAGES MEASURED TO  
COMMON WIRING WITH "VOLTOHMYST"  
SHOULD HOLD WITHIN ± 20%



# RCA VICTOR

## MODELS 9-ED-2LE, 9-ED-2KF

Chassis No. RS-170D

### STYLUS REPLACEMENT

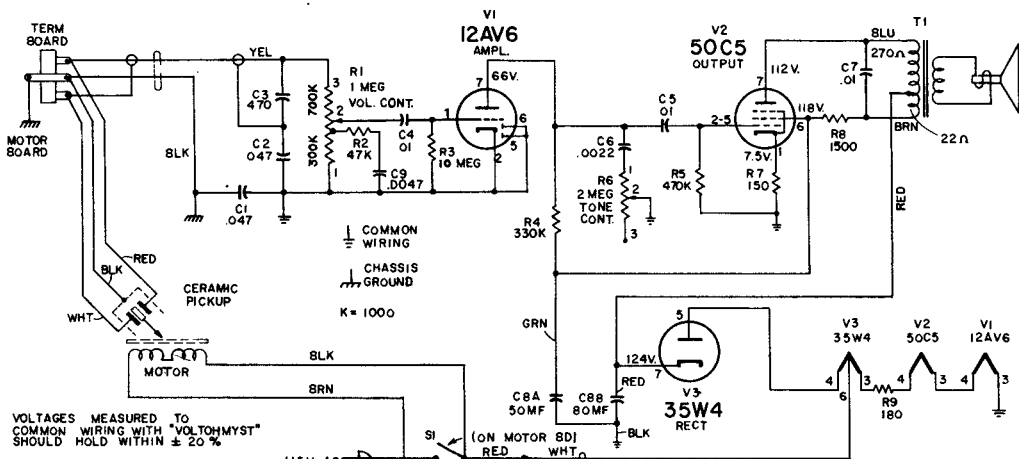
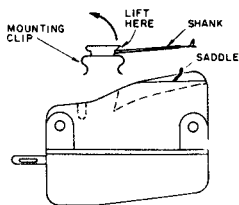

VOLTAGES MEASURED TO  
COMMON WIRING WITH "VOLTOHMYST"  
SHOULD HOLD WITHIN ± 20%

NOTE—Power to the amplifier chassis is controlled  
by the power switch on the record changer.



# RCA VICTOR

## Automatic Record Player MODEL 8-EY-31

Chassis No. RS-153A  
Record Changer No. RP-190D-1

### Stylus Replacement—Pickup #103238

The stylus assembly is held in position by a pressure fit only. To remove stylus assembly, pull straight outward away from pickup.

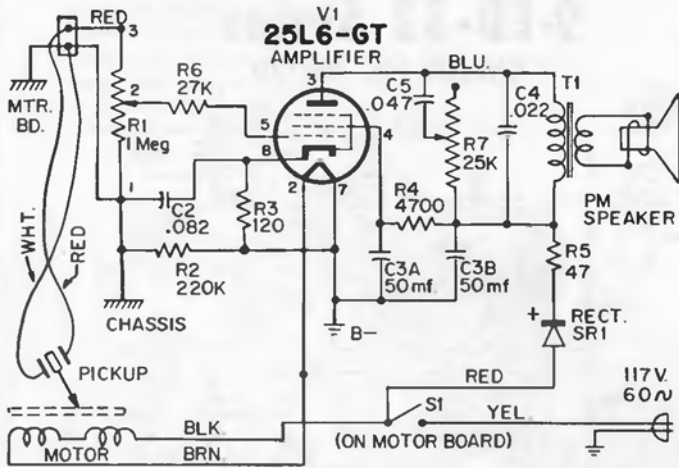

### Pickup Height Adjustment

Adjust knurled nut "A" until the distance (during change cycle) between the top of the turntable and the stylus point is approximately 1 1/8".

### Pickup Landing Adjustment

Adjust the screw driver landing adjustment stud "B" so the stylus lands 2 1/2" ± 1/64" from the side of the center post.

### Tripping Adjustment

Adjust the eccentric tripping stud "C" until the mechanism trips when the stylus is 1 9/32" from the side of the center post.

### Record Dropping Adjustment

Turn the eccentric screw "E" until the record drops to the turntable without striking the pickup arm.

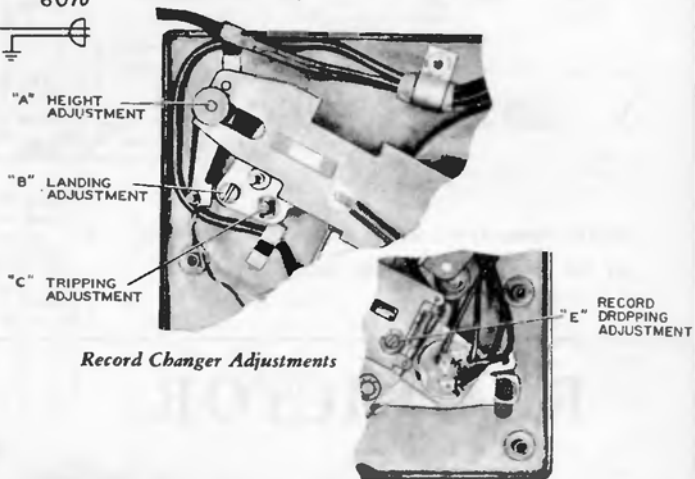

# RCA VICTOR

## MODELS 9-ES-6H, 9-ES-6J

Chassis No. RS-157B  
Record Changer RP-205B-4

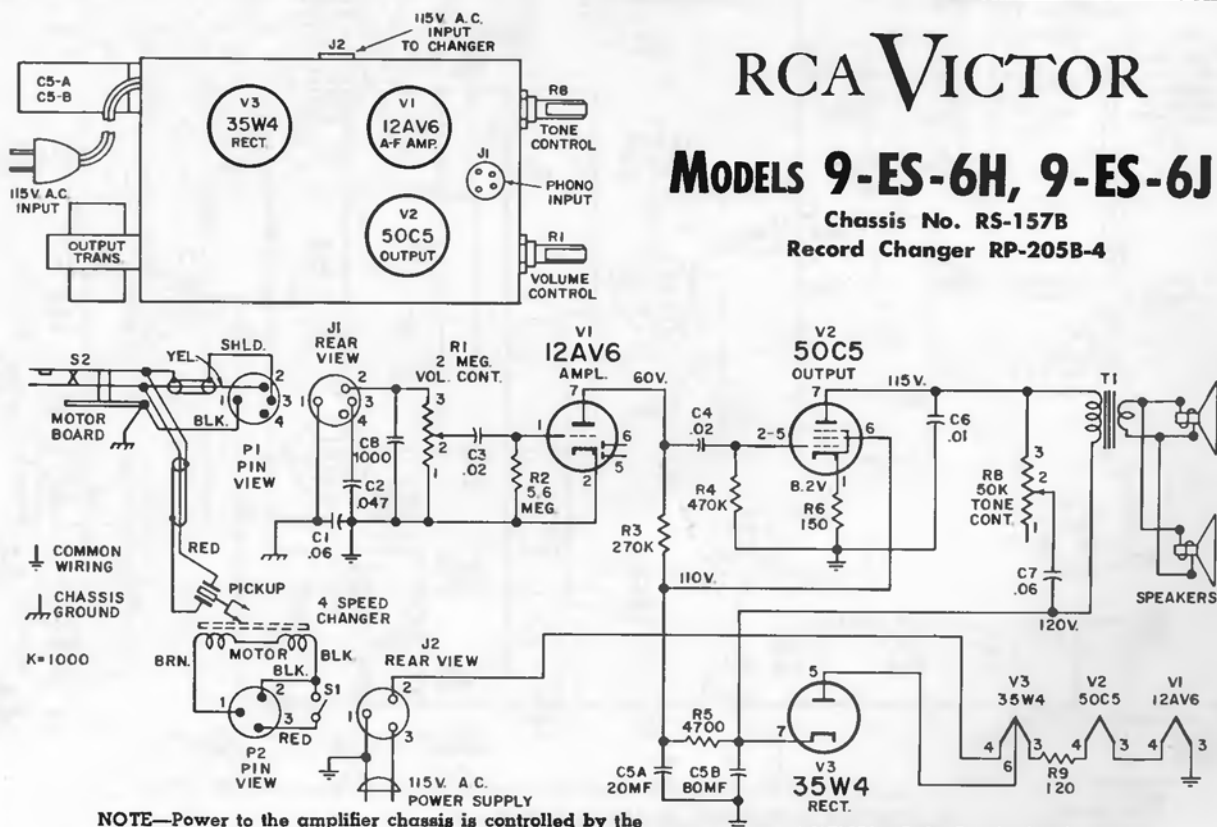

NOTE—Power to the amplifier chassis is controlled by the power switch on the record changer.

VOLTAGES MEASURED TO COMMON WIRING WITH "VOLTOHMYST" SHOULD HOLD WITHIN ±20%



# RCA VICTOR

## 9-ED-32 Series

Chassis No. RS-170

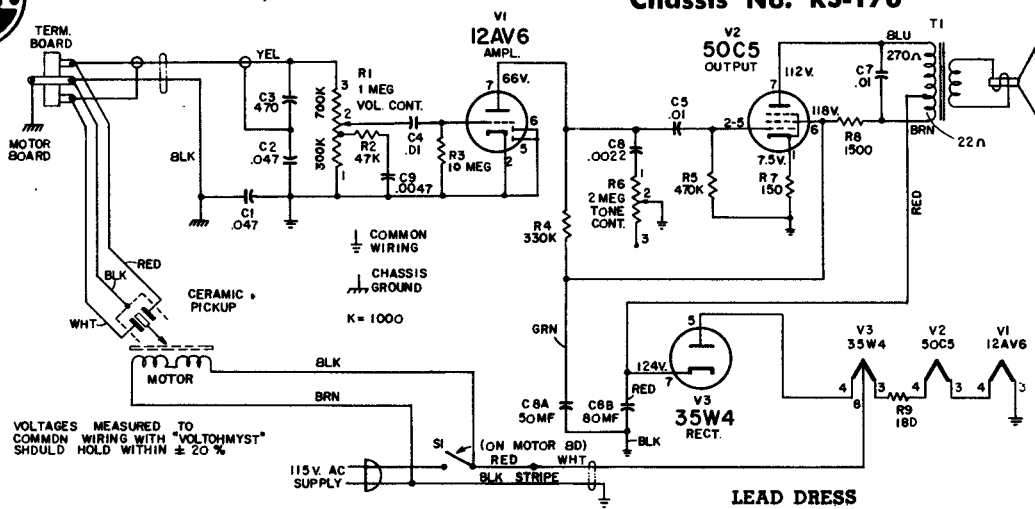

1. Dress R2, R3 and C6 against chassis.
2. Dress all heater and a.c. power leads close to chassis.
3. B- power lead (white with black stripe) should be dressed from knot at entrance to chassis under the lead dress terminal, and then under the electrolytic capacitor and over to its tie point on terminal board.
4. The green electrolytic capacitor lead and the blue output transformer lead should be dressed well into corner of chassis at the V3 tube socket.
5. Dress all components away from R9.

**NOTE**—Power to the amplifier chassis is controlled by the power switch on the record changer.

# RCA VICTOR

## MODELS SHF-8, SHF-9

Chassis No. RS-158D, RS-158F

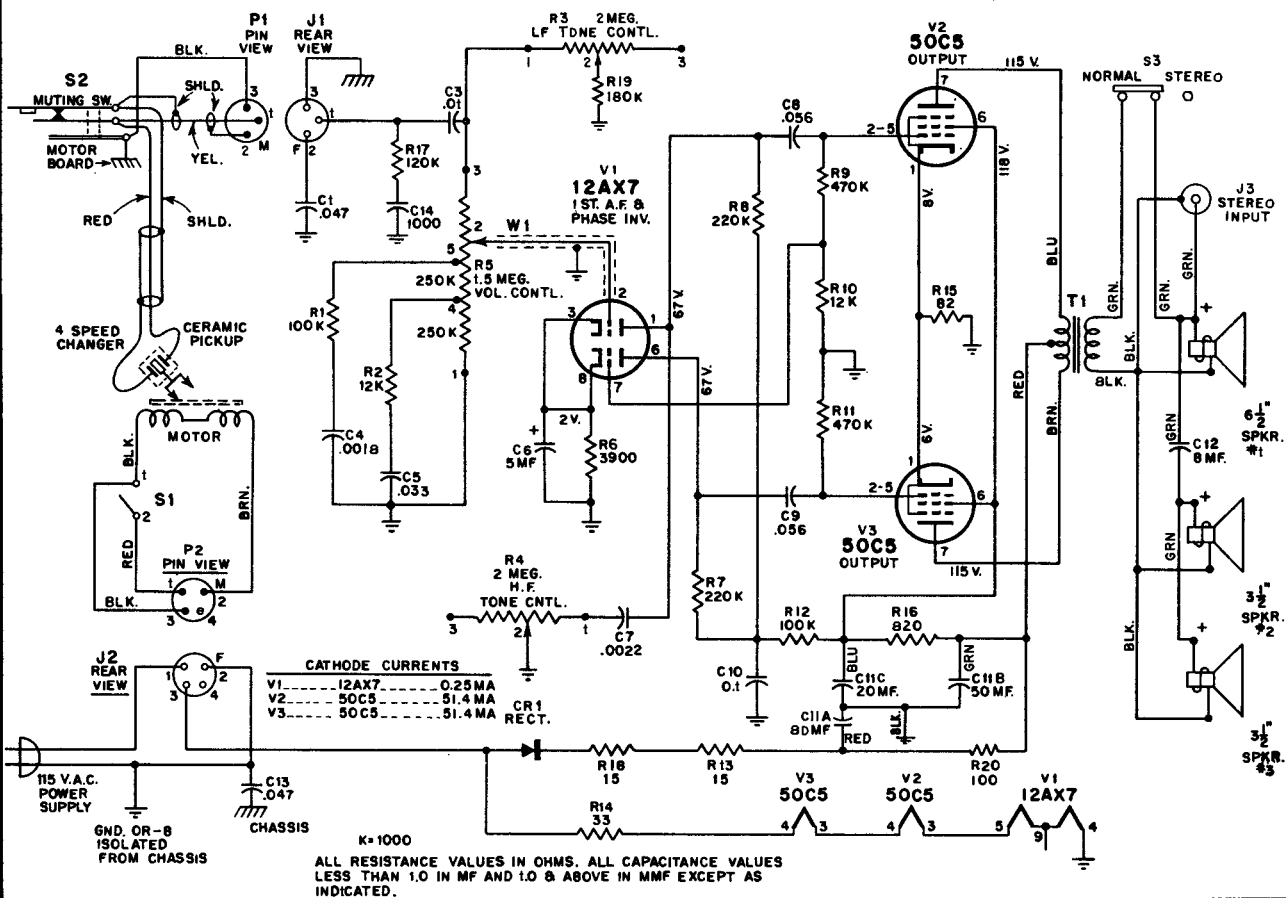

### REMOVAL OF CHASSIS FROM CRADLE

- Remove volume and tuning control knobs.
- Disconnect three speaker leads.
- Remove bottom screw.
- Remove one screw at outside of cradle (close to speaker).
- Swing right end of chassis (as viewed from rear) to the rear of the cradle.
- Disengage chassis from cradle by moving endways.

### 1958 RADIO SERVICING INFORMATION

# RCA VICTOR

## 9-C-7, 9-C-8, 9-X-10 SERIES

Chassis No. RC-1166A, No. RC-1166B

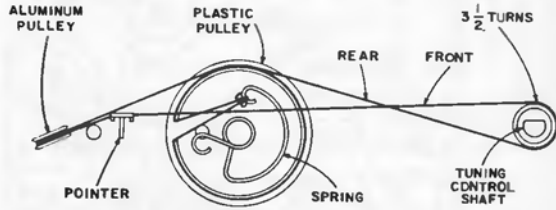
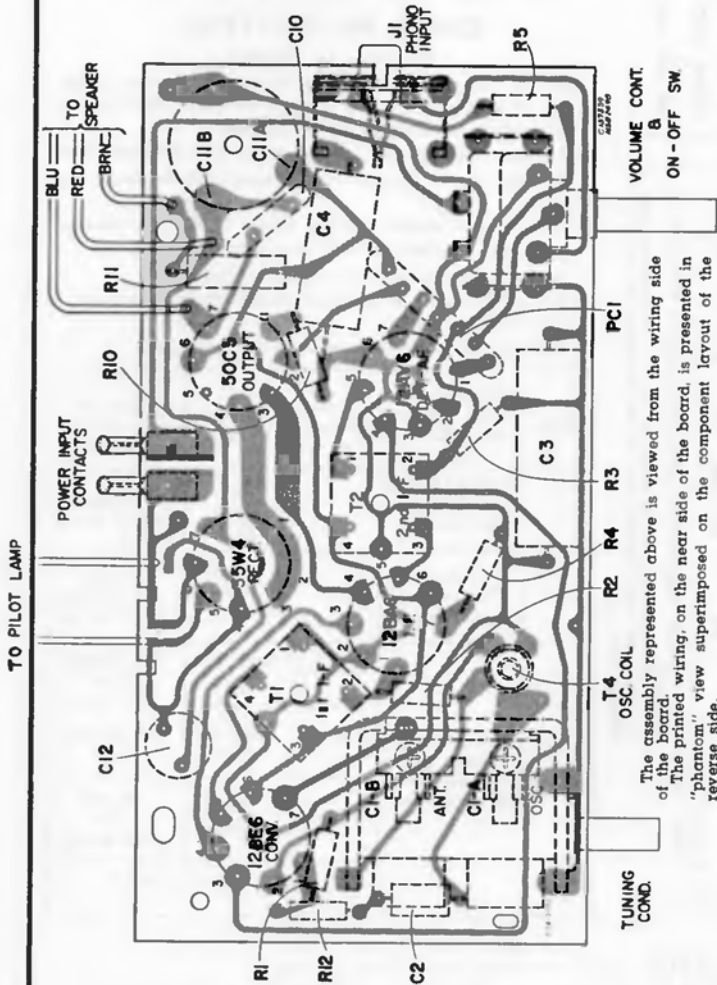

ASSEMBLY SHOWN WITH TUNING CONDENSER PLATES FULLY MESHD.

### ALIGNMENT PROCEDURE

Step	Connect the high side of test-oscillator to—	Tune test-osc. to—	Turn radio dial to—	Adjust the following for max. output
1	12BA6 I-F grid through .01 mfd. capacitor	455 kc	Quiet-point 1,600 kc end of dial	T2 (top) 2nd I-F trans.
2	Stator of C1-B through .01 mfd.			T1 (top and bottom) 1st I-F trans.
3	Short wire placed near loop to radiate signal	1,620 kc	Gang fully open	osc. trimmer C1-A
4		1,400 kc	1,400 kc signal	ant. trimmer C1-B
5		600 kc	600 kc signal	osc. coil T-4 (rock gang)
6	Repeat steps 3, 4, and 5			

The assembly represented above is viewed from the wiring side of the board. The printed wiring, on the near side of the board, is presented in "phantom" view superimposed on the component layout of the reverse side.

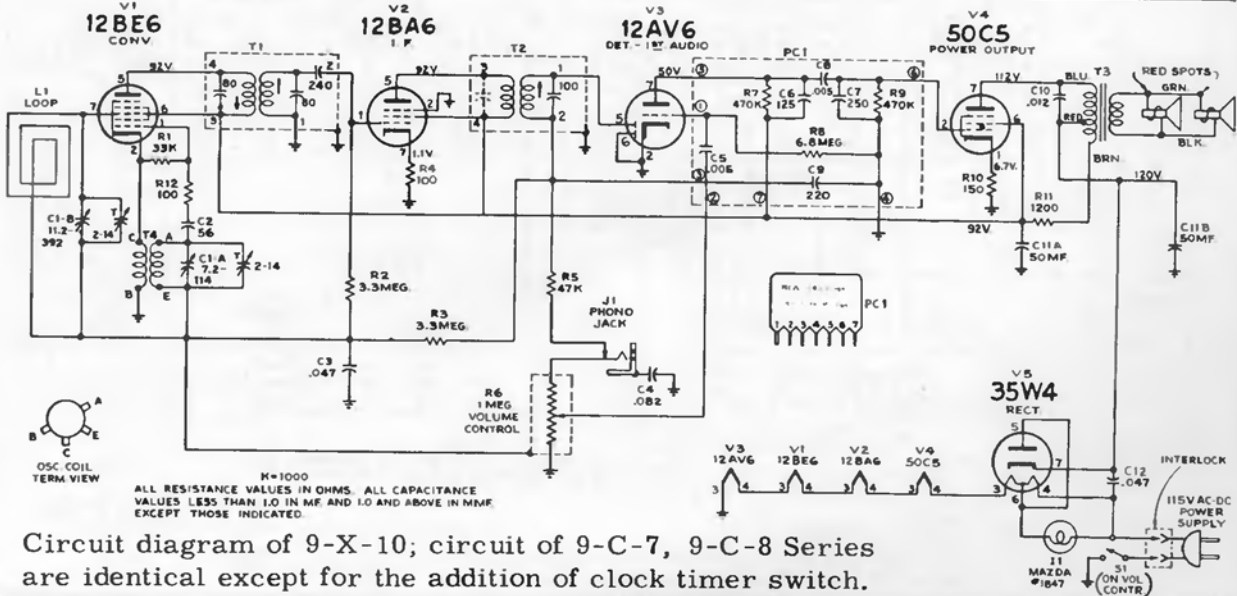

Circuit diagram of 9-X-10; circuit of 9-C-7, 9-C-8 Series are identical except for the addition of clock timer switch.



# RCA VICTOR

## MODELS 9-US-5H, 9-US-5KE

Chassis No. RC-1170A

### REMOVAL OF CHASSIS

1. Remove two screws at ends of chassis compartment panel.
2. Pull on attachment cord to separate cord from interlock contacts which are attached to the cabinet.
3. Unsolder three speaker leads and two loop antenna leads.
4. Unsolder record changer audio leads (yellow, black and shield).
5. Unsolder two record changer power leads and interlock leads from terminals at rear edge of circuit board.
6. Pull knobs off (volume, tone/switch, tuning).
7. Remove two nuts which hold chassis mounting bracket to front baffle board.
8. Remove two screws at rear edge of circuit board.

Step	Connect the high side of test-oscillator to—	Tune test-osc. to—	Turn radio dial to—	Adjust the following for max. output
1	12BA6 I-F grid through .01 mfd. capacitor	455 kc	Quiet-point 1,600 kc end of dial	T2 (top) 2nd I-F trans.
2	Stator of C1-B through .01 mfd.		1,400 kc signal	T1 (top and bottom) 1st I-F trans.
3		1,620 kc	Gang fully open	osc. trimmer C1-A
4	Short wire placed near loop to radiate signal	1,400 kc	1,400 kc signal	ant. trimmer C1-B
5		600 kc	600 kc signal	osc. coil T-4 (rock gang)
6	Repeat steps 3, 4, and 5			

Circuit Board Wiring and Components — View from Wiring Side

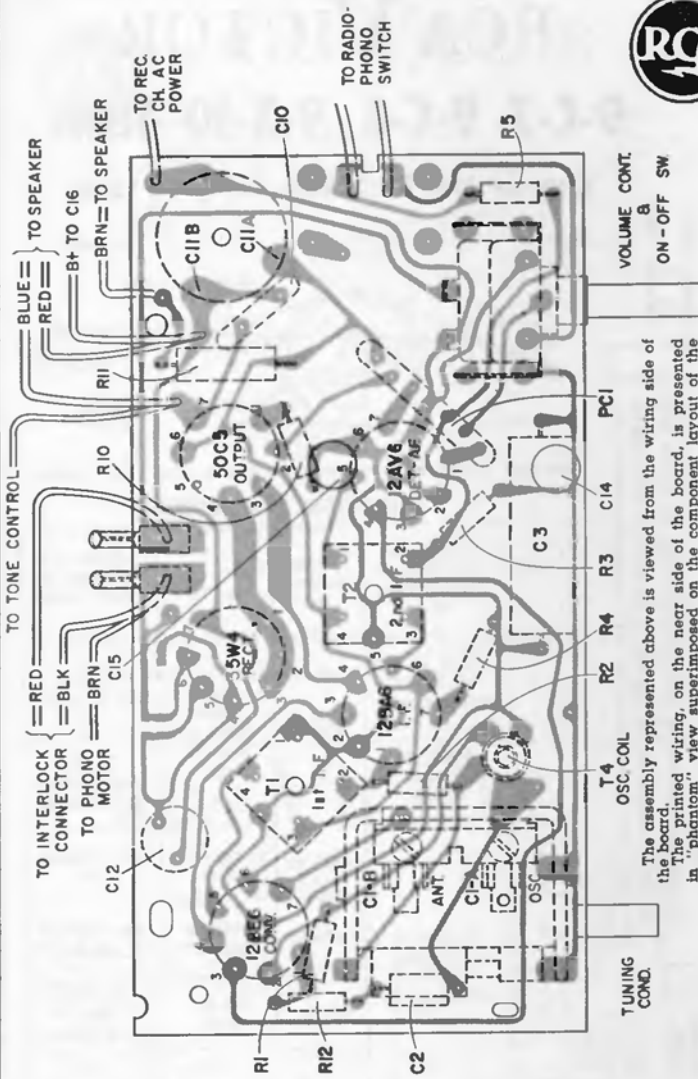

The assembly represented above is viewed from the wiring side of the board. The printed wiring, on the rear side of the board, is presented in "phantom" view superimposed on the component layout of the reverse side.

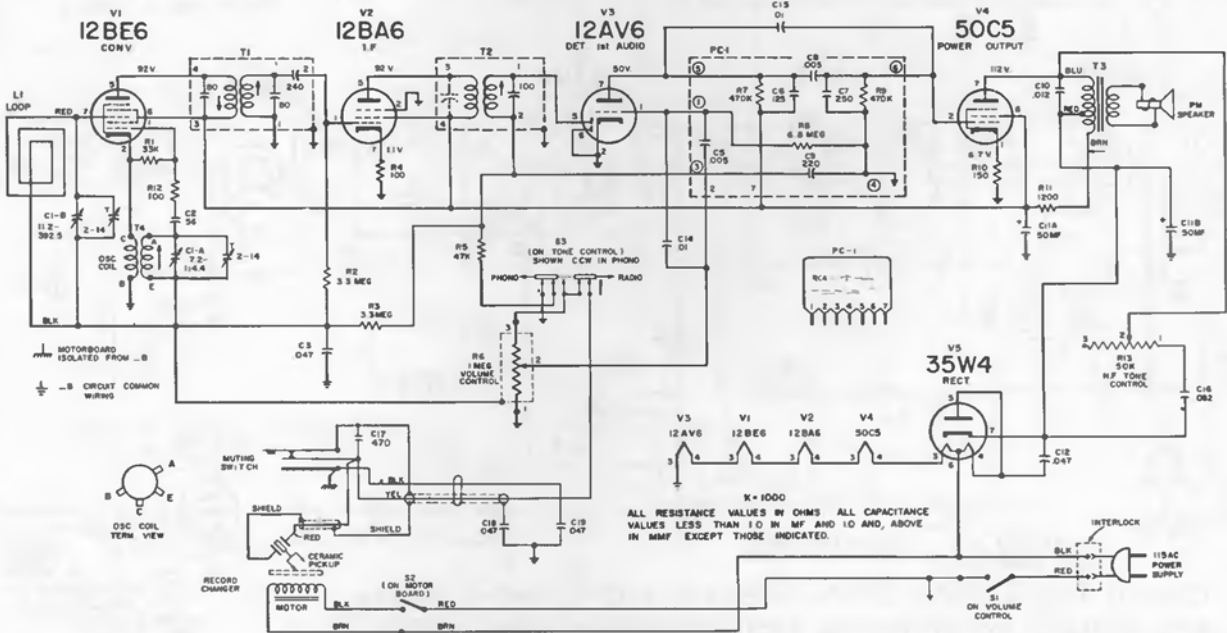



# RCA VICTOR

## 9-XL-1 SERIES

Chassis No. RC-1167A

### TO REMOVE BACK COVER

1. Loosen screw at bottom-center of back cover and move slide upward out of slot in cabinet.
2. Tilt outward to free interlock contacts, then drop from top grooves.

Avoid strain on loop connections.

### REMOVAL OF CHASSIS

1. Pull off volume control and tuning knobs.
2. Remove back cover.
3. Remove two screws holding dial assembly to cabinet.

### LEAD DRESS

1. Leads from the chassis to the speaker should be dressed between the electrolytic capacitor and the left end of the cabinet.

### ALIGNMENT PROCEDURE

Step	Connect the high side of test-oscillator to—	Tune test-osc. to—	Turn radio dial to—	Adjust the following for max. output
1	12BA6 I-F grid through .01 mfd. capacitor	455 kc	Quiet-point 1,600 kc end of dial	T2 (top) 2nd I-F trans.
2	Stator of C1-B through .01 mfd.			T1 (top and bottom) 1st I-F trans.
3		1,620 kc	Gang fully open	osc. trimmer C1-A
4	Short wire placed near loop to radiate signal	1,400 kc	1,400 kc signal	ant. trimmer C1-B
5		600 kc	600 kc signal	osc. coil T-4 (rock gang)
6	Repeat steps 3, 4, and 5			

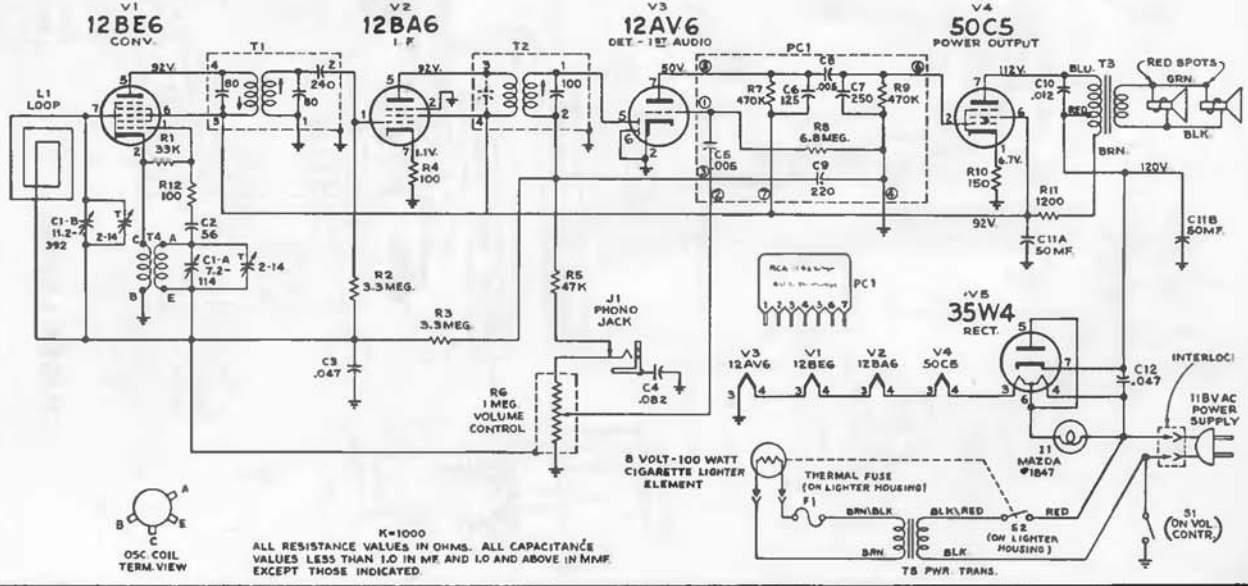
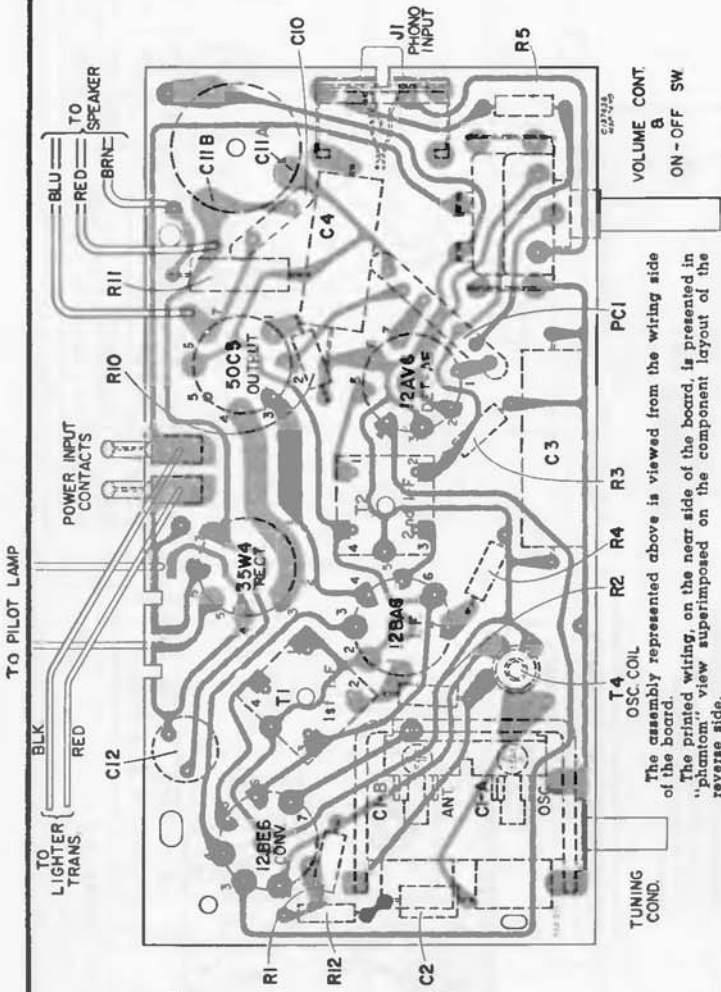

OSC. COIL TERM. VIEW

K=1000  
ALL RESISTANCE VALUES IN OHMS. ALL CAPACITANCE VALUES LESS THAN 1.0 IN MF. AND 1.0 AND ABOVE IN MMF. EXCEPT THOSE INDICATED.

SENTINEL and SPARTAN

Radio Chassis CR-729

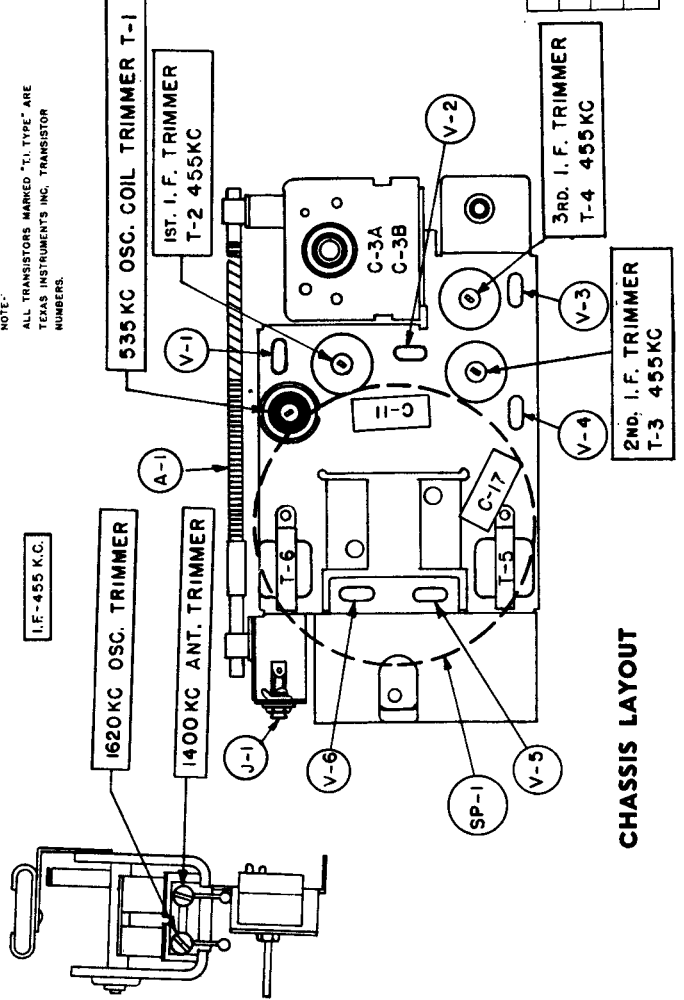
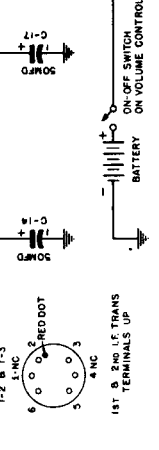
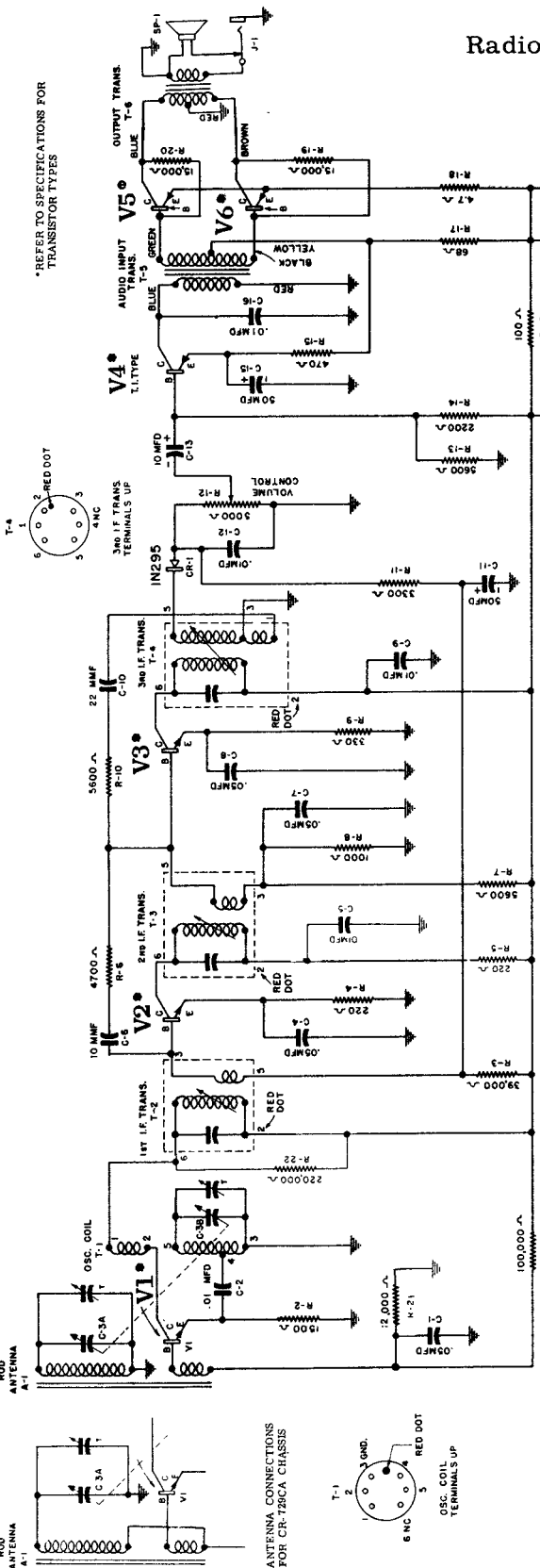

VOLTAGE TABLE

CHASSIS	R-1	R-2	R-5	R-17	R-19	R-20	R-21	R-22	C-1	C-2	C-5	C-10
CR-729AA	100K	1500	220	100	OMIT	OMIT	220K	.05	.01	.01	.01	18
CR-729BA	100K	1500	OMIT*	68	15K	15K	OMIT	.05	.01	OMIT	OMIT	22
CR-729CA	3300	2700	OMIT*	68	15K	15K	12K	.01	.005	OMIT	OMIT	22

\* Replaced by Buss Wire

**SYLVANIA**

**CHASSIS:** 1-617-1  
**MODELS:** 3203 AND 3204

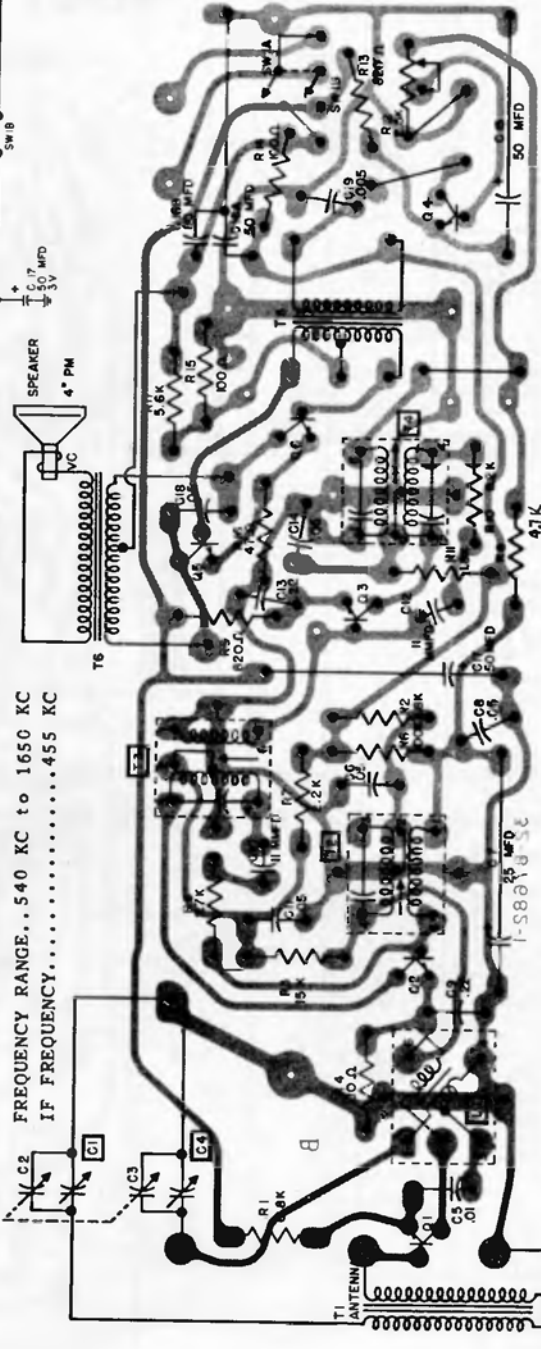
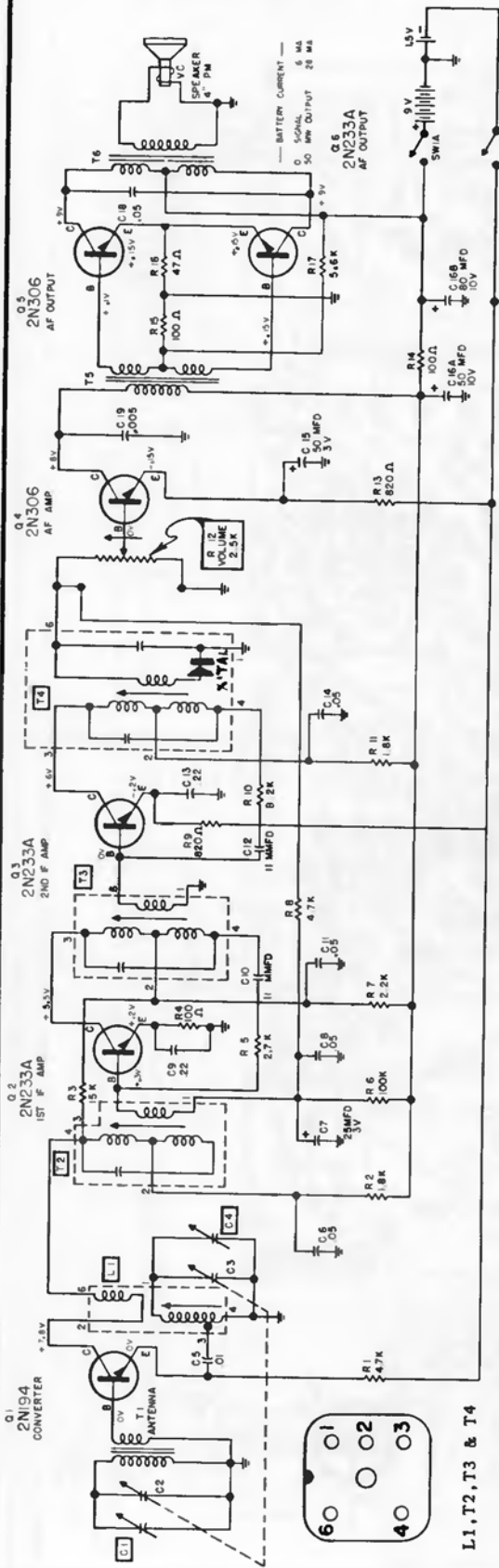

FREQUENCY RANGE...540 KC to 1650 KC  
 IF FREQUENCY.....455 KC

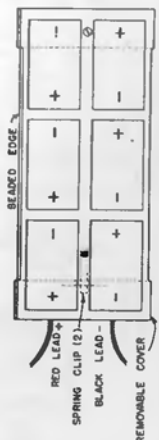
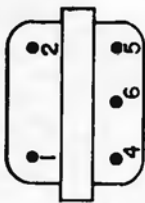

1. Open case by depressing top of front cover near handle ends while pulling top of rear cover backward.
  2. Remove knobs (2) and remove screw (1) behind tuning knob.
  3. Remove screws (2) securing chassis board to mounting brackets. (NOTE: One screw is insulated from chassis by a fiber washer. Replace this washer when installing chassis board.)
- The chassis may now be lifted from case for alignment and maintenance.

**SYLVANIA**

**CHASSIS:** 1-620-1  
**MODELS:** 3305

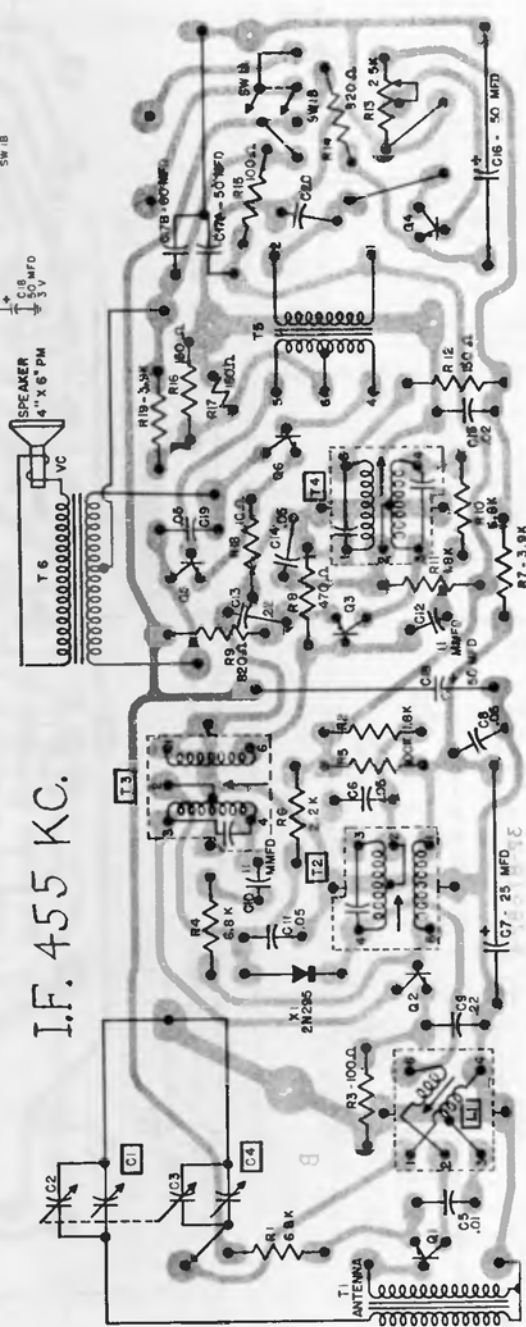
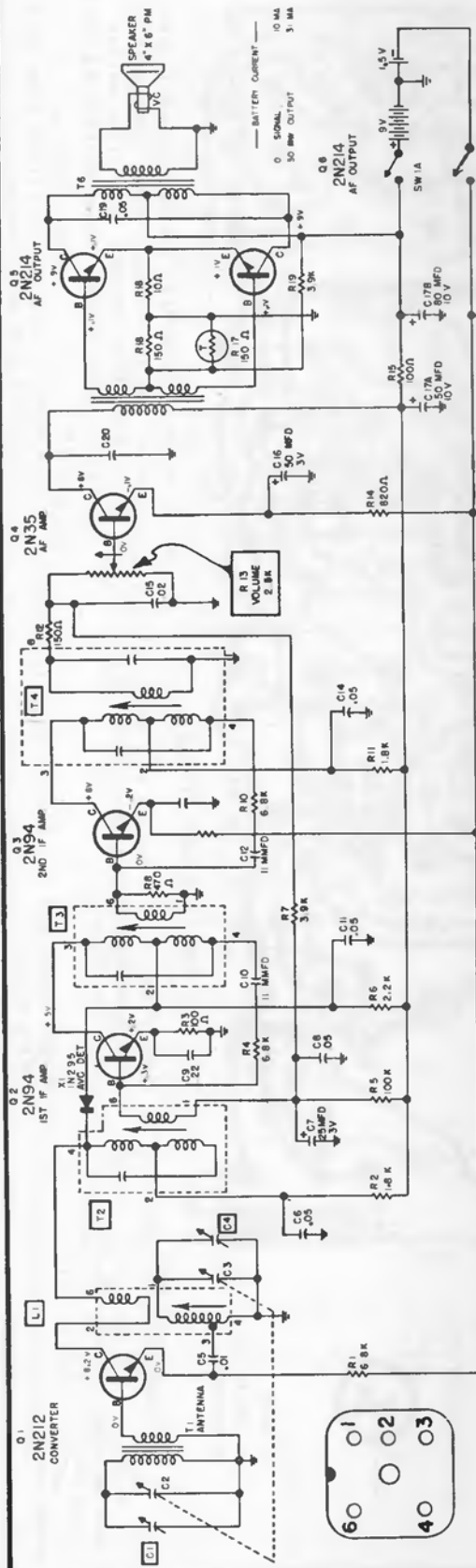

I.F. 455 KC.

L1, T2, T3 & T4

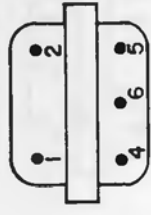

BOTTOM VIEW OF T5



TRANSISTOR

B-BASE  
C-COLLECTOR  
E-EMITTER

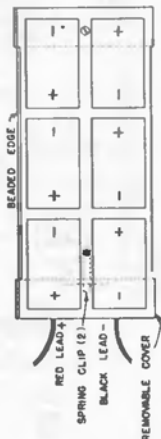

**CHASSIS BOARD REMOVAL**

1. Open case by depressing top of front cover near handle ends while pulling top of rear cover backward.
2. Remove knobs (2) and remove screw (1) behind tuning knob.
3. Remove screws (2) securing chassis board to mounting brackets. (NOTE: One screw is insulated from chassis by a fiber washer. Replace this washer when installing chassis board.)

The chassis may now be lifted from case for alignment and maintenance.



VOLUME R-18, MOST-OFTEN-NEEDED 1958 RADIO SERVICING INFORMATION

SYLVANIA Amplifier Chassis 1-609-6, Model 4307

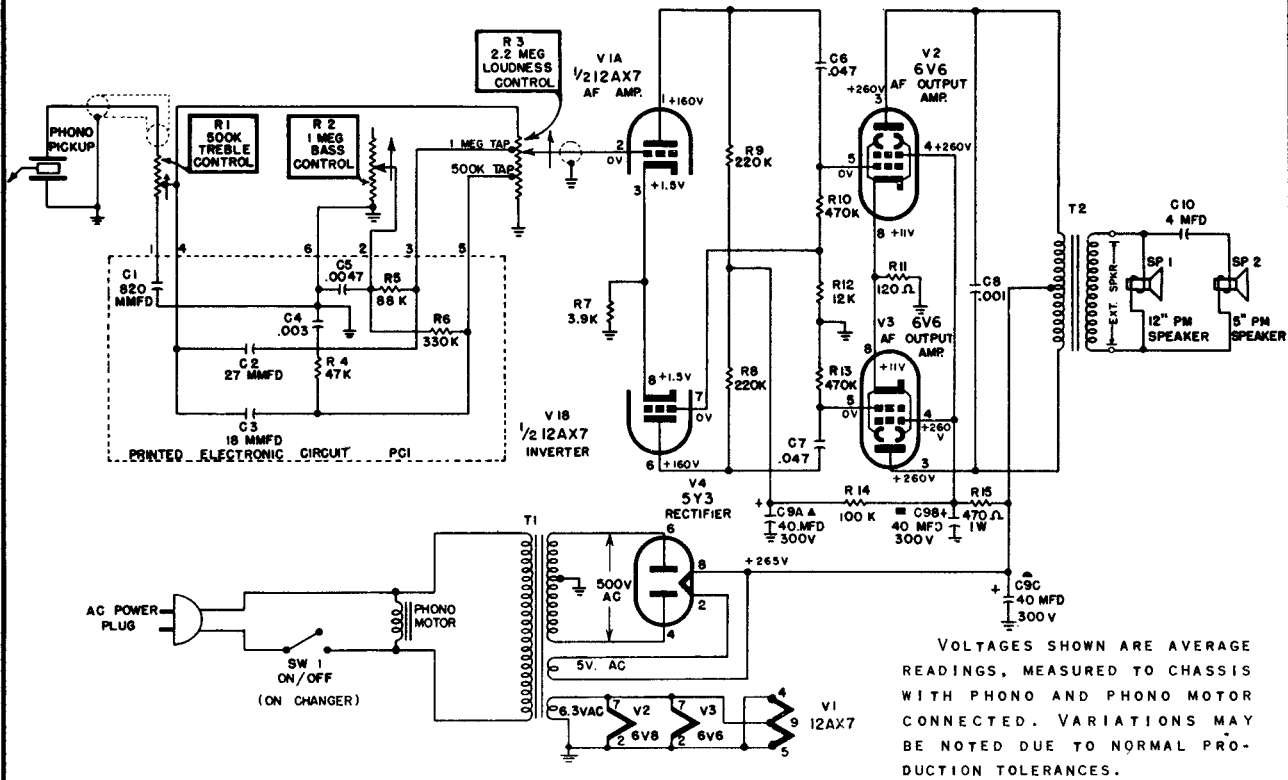

SYLVANIA Amplifier Chassis 1-621-1, 1-621-2, Models 4308, 4309

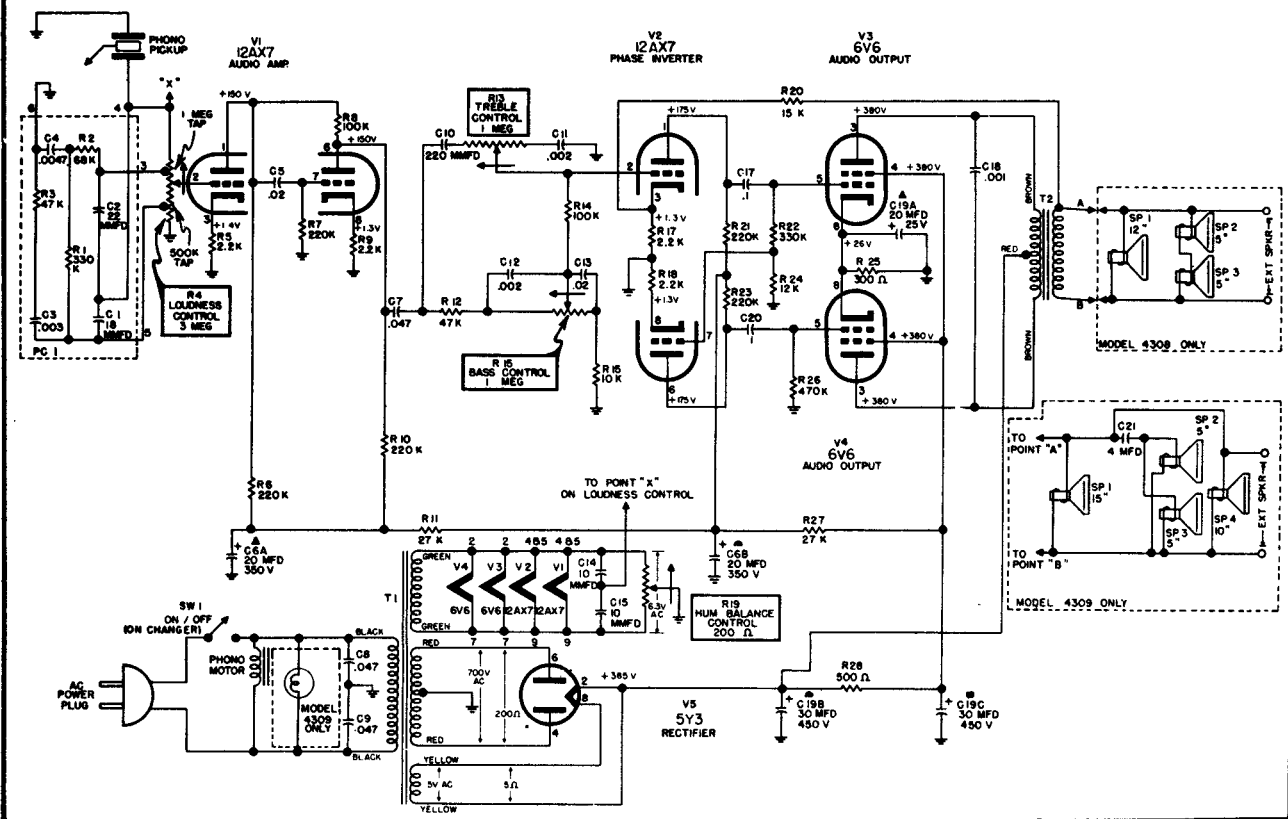

**SYLVANIA**  
Chassis 1-623-1  
Model 4406

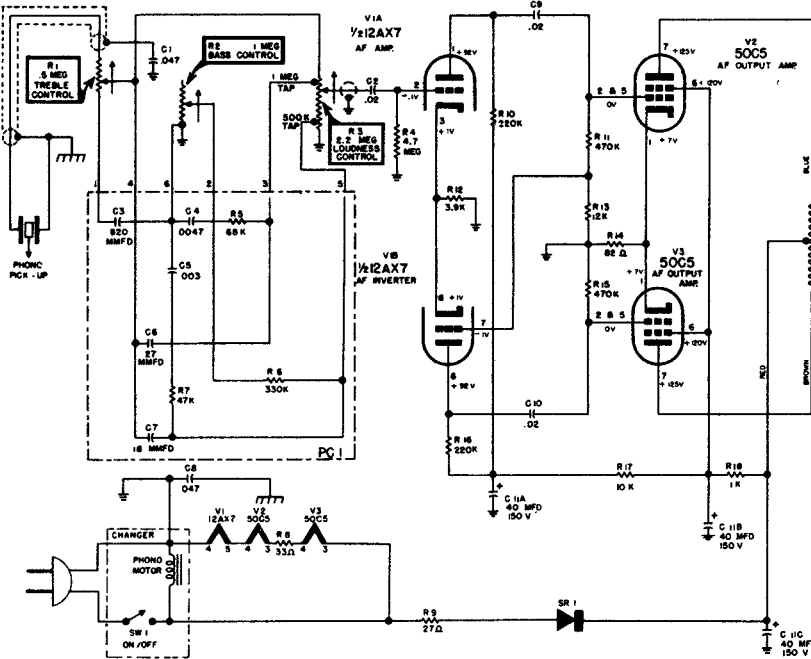

**SCHEMATIC NOTES**

1. VOLTAGES ARE AVERAGE READINGS MEASURED TO NEG. "B" USING VTVM, WITH PHONO AND MOTOR CONNECTED. POWER SOURCE 117V, 60~ "VARIAC" REGULATED. VARIATIONS MAY BE NOTED DUE TO NORMAL PRODUCTION TOLERANCES.
2. SYMBOL "⊖" DESIGNATES CONNECTION TO NEG. "B". SYMBOL "⏏" DESIGNATES CONNECTION TO CHASSIS METAL.

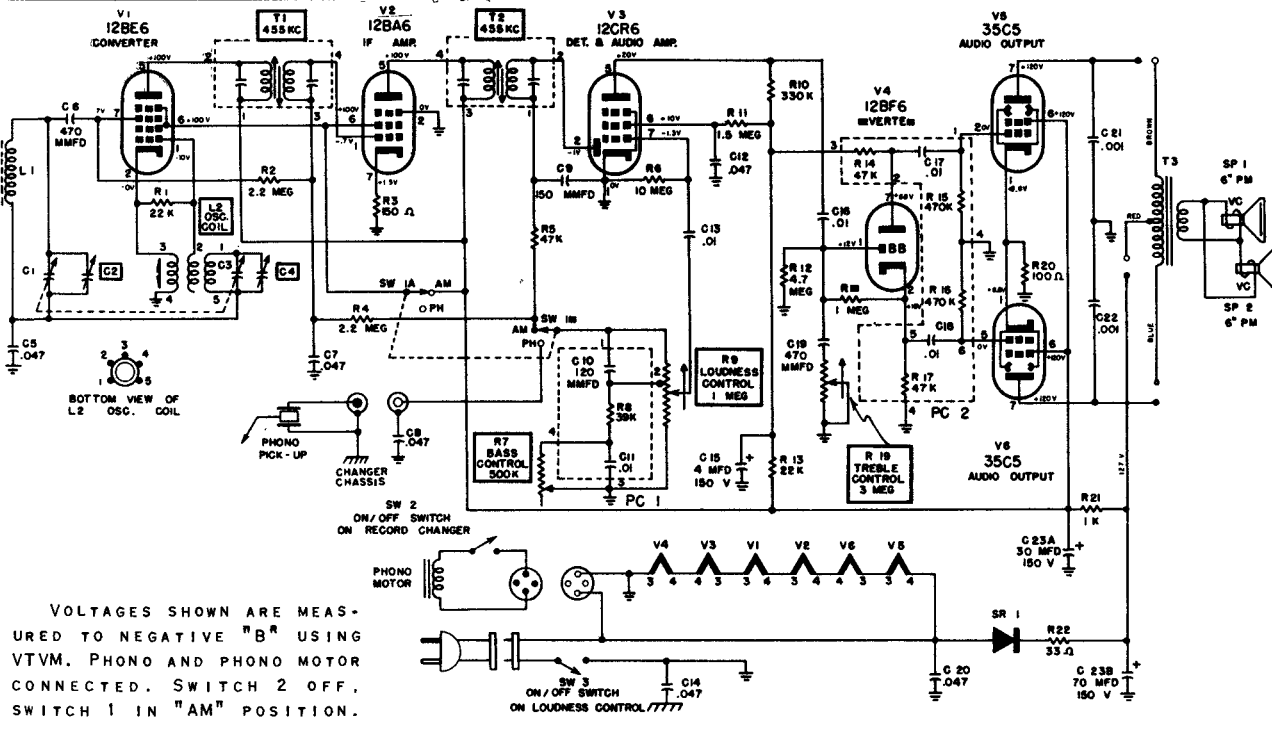

VOLTAGES SHOWN ARE MEASURED TO NEGATIVE "B" USING VTVM. PHONO AND PHONO MOTOR CONNECTED. SWITCH 2 OFF, SWITCH 1 IN "AM" POSITION.

**SYLVANIA**  
Chassis 1-624-1  
Model 4501

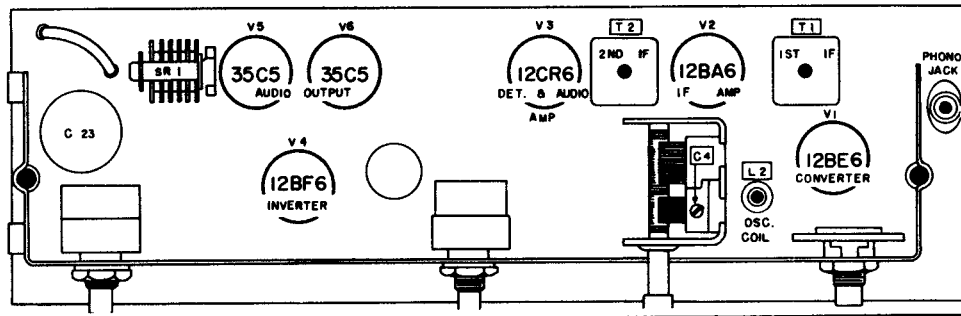

# TRAVLER MODEL 46-37

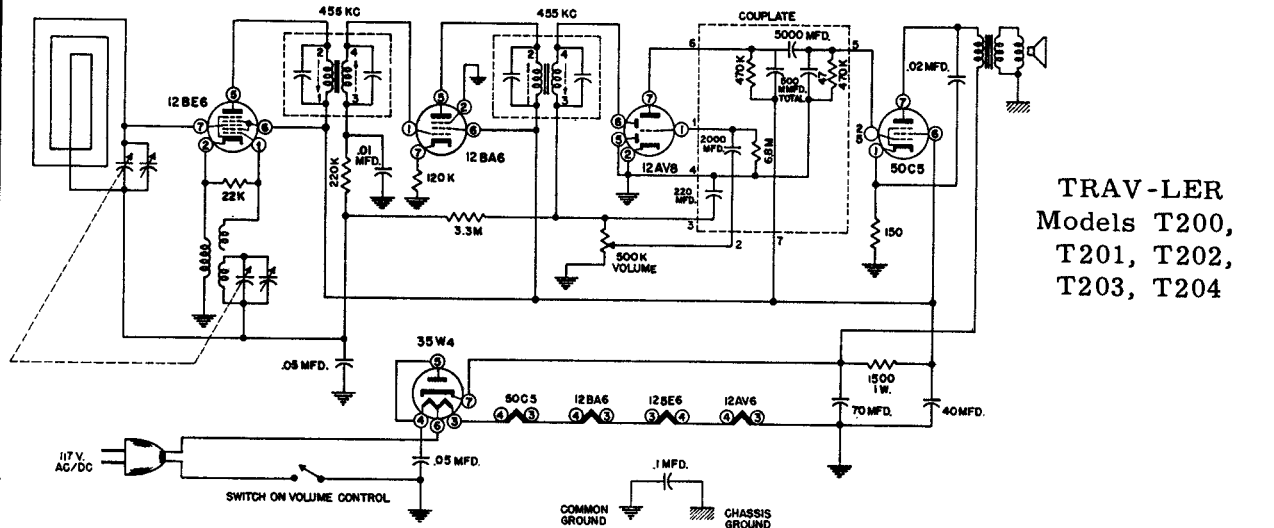
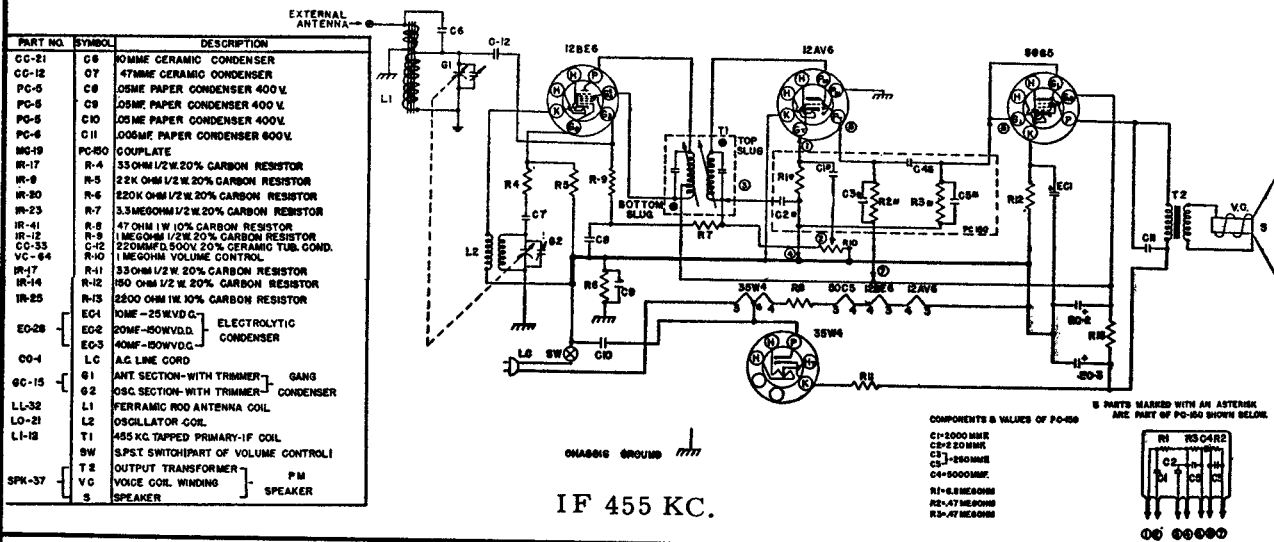

## TRAV-LER Chassis 236 Models T210, T211, T212 and T213

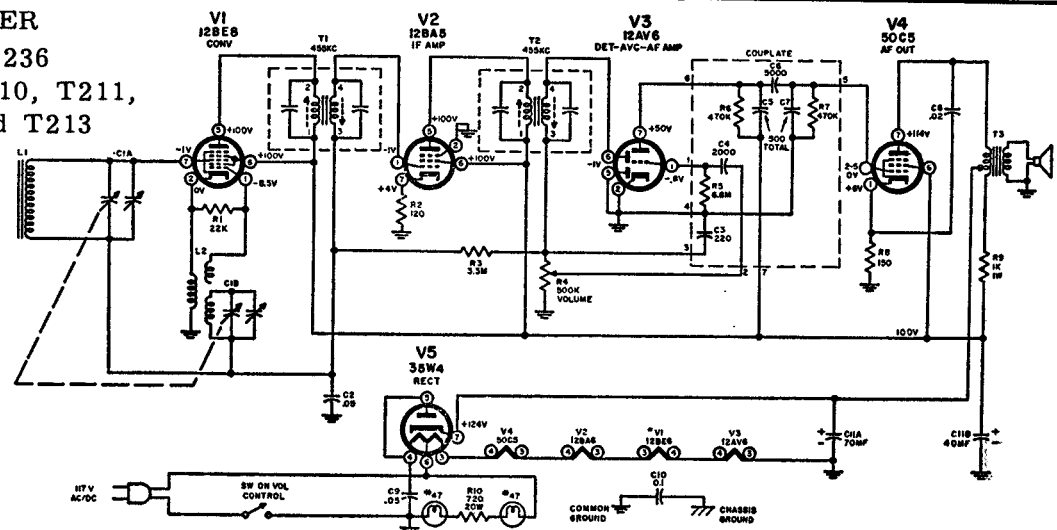

# VOLUME R-18, MOST-OFTEN-NEEDED 1958 RADIO SERVICING INFORMATION

TRAV-LER RADIO Models 56C220, 56C230, 56C231, 56C232, 56C233

The diagram below is exact for above listed sets. Model 56C240 is very similar but includes pilot light and phono input jack and switch.

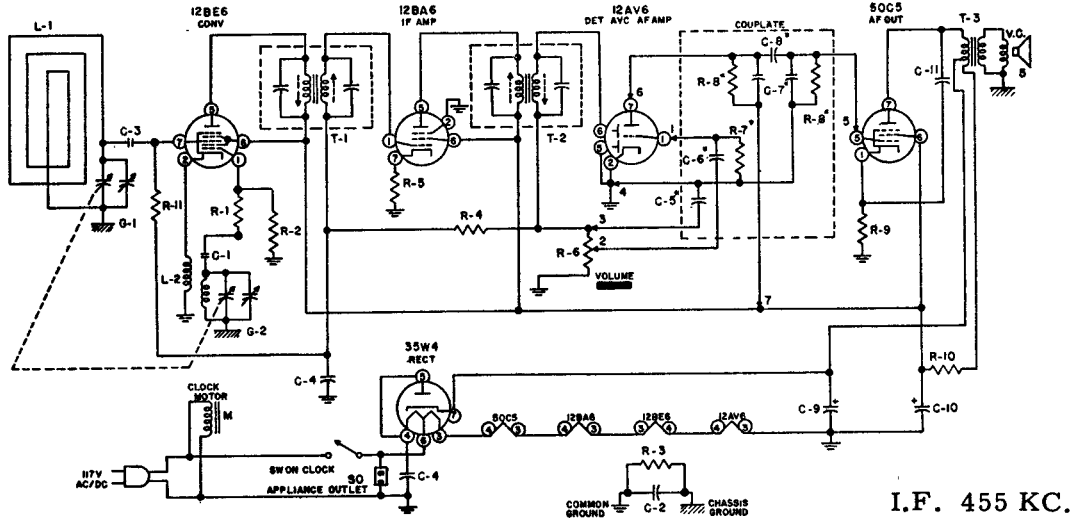

PART NO.	DESCRIPTION	PART NO.	DESCRIPTION	PART NO.	DESCRIPTION
IR-4	R-1 47Ω RESISTOR 1/2W. 20%	CC-12	C-1 47 MMFD CERAMIC CONDENSER	SPK-55	4"x6" RM SPEAKER
IR-45	R-2 22MΩ RESISTOR 1/2W. 10%	PC-8	C-2 1 MFD. CONDENSER 400 V.	V.C.	VOICE COIL
IR-20	R-3 220MΩ RESISTOR 1/2W. 20%	CC-33	C-3 220 MMFD. 500V. 20% CER COND.	T-3	OUTPUT TRANSFORMER
IR-23	R-4 3.3MEG RESISTOR 1/2W. 20%	PC-5	C-4 .05 MFD. CONDENSER 400 V.	LL-48	LOOP ANTENNA
WR-155	R-5 120Ω RESISTOR 1/2W. 10%	MO-19	C-5 .220 MMFD.	LO-27	OSC COIL
VC-101	R-6 1MEG. VOLUME CONTROL		C-6 .002 MFD.	50-54	APPLIANCE OUTLET SOCKET
MG-1B	R-7 6.8MEG.		C-7 .250 MMFD.		
	R-8 470MΩ.		C-8 .005 MFD.		
IR-98	R-9 150Ω RESISTOR 1/2W. 10%	EC-68	C-9 70 MFD. 150V.V.O.ELECTROLYTIC	CK-7	ELECTRIC CLOCK
IR-42	R-10 100Ω RESISTOR 1/2W. 10%		C-10 40 MFD.		
IR-12	R-11 1MEG. RESISTOR 1/2W. 20%	PC-47	C-11 .02 MFD. CONDENSER 400V.		
LI-1B	T-1 INPUT LF TRANSFORMER	BC-24	G-1 TUNING CONDENSER		
	T-2 OUTPUT LF TRANSFORMER		G-2		

## TRAV-LER RADIO MODEL 5220

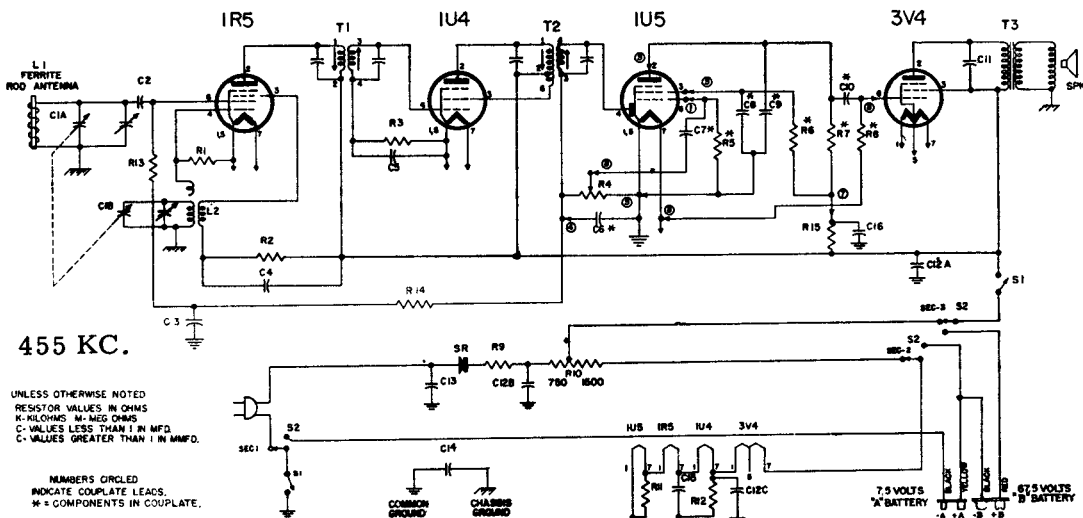

UNLESS OTHERWISE NOTED  
RESISTOR VALUES IN OHMS  
K- KILOHMS M- MEG OHMS  
C- VALUES LESS THAN 1 IN MFD.  
C- VALUES GREATER THAN 1 IN MFD.

NUMBERS CIRCLED  
INDICATE COUPLATE LEADS.  
\* - COMPONENTS IN COUPLATE.

PART NO.	SYMBOL	DESCRIPTION	PART NO.	SYMBOL	DESCRIPTION	PART NO.	SYMBOL	DESCRIPTION
SC-21	C1A	TUNING CAPACITOR	PC-3	C16	1MFD PAPER CONDENSER 400V.	LI-15	T1	1/2" IF COIL
CC-57	C2	220 MMFD CERAMIC CONDENSER 500V.	IR-43	R1	100Ω 1/2W. 10% CARBON RESISTOR	LI-16	T2	2 1/2" IF COIL
CC-2	C3	347MFD PAPER CONDENSER 700V.	IR-48	R2	47KΩ 1/2W. 10%	AT-21	T3	OUTPUT TRANSFORMER
CC-29	C4	.001 MFD. CERAMIC CONDENSER 500V.	IR-151	R3	10MΩ 1/2W. 5% CARBON RESISTOR	ST-21	S1	SWITCH ON VOLUME CONTROL, D.P.S.T.
CC-37	C5	.001 MFD. CERAMIC CONDENSER 500V.	VC-187	R4	2 MEG OHM VOLUME CONTROL	SP-23	S2	POWER CHANGE OVER, 3 POLE, 2 POSITION
	C6	150MMFD.	WR-3	R5	10 MEG OHM	SR-2	S3	7.5V. 7A. RECTIFIER
	C7	.002 MFD.	WR-6	R6	RESISTORS IN COUPLATE	SPK-51	SPK	4" RM SPEAKER
	C8	150MMFD.	WR-7	R7	1			
	C9	150MMFD.	WR-8	R8	3 1/2 MEG OHMS			
	C10	.003 MFD.	WR-9	R9	75 OHM 1/4 WATT FLEXIBLE WIREWOUND RESISTOR			
	C11	.002 MFD.	WR-29	R10	5820 OHMS TAPPED AT 750 OHMS - CARBORNE			
	C12	150MMFD.	IR-140	R11	150 OHMS 1/2W. 5% CARBON RESISTOR			
	C13A	50MMFD. BOY ELECTROLYTIC CONDENSER	IR-149	R12	580 OHMS 1/2W. 5% CARBON RESISTOR			
	C13B	50MMFD.	IR-108	R13	1 MEG OHMS 1/2W. 10% CARBON RESISTOR			
	C13C	50MMFD.	IR-109	R14	1.5 MEG OHMS 1/2W. 10% CARBON RESISTOR			
	C14	107MFD. WOUND PAPER CONDENSER 400V.	IR-180	R15	270Ω OHM 1/2W. 10% CARBON RESISTOR			
	C15	1 MFD. PAPER CONDENSER 400V.	LL-48	L1	LOOP ROD ANTENNA			
	C16	1 MFD. 300V.	LL-25	L2	OSCILLATION COIL			

# Westinghouse

**MODELS**  
**H-570T4**

(Mocha)

**H-571T4**

(Ivory)

**H-572T4**

(Pink)

Chassis V-2239-4

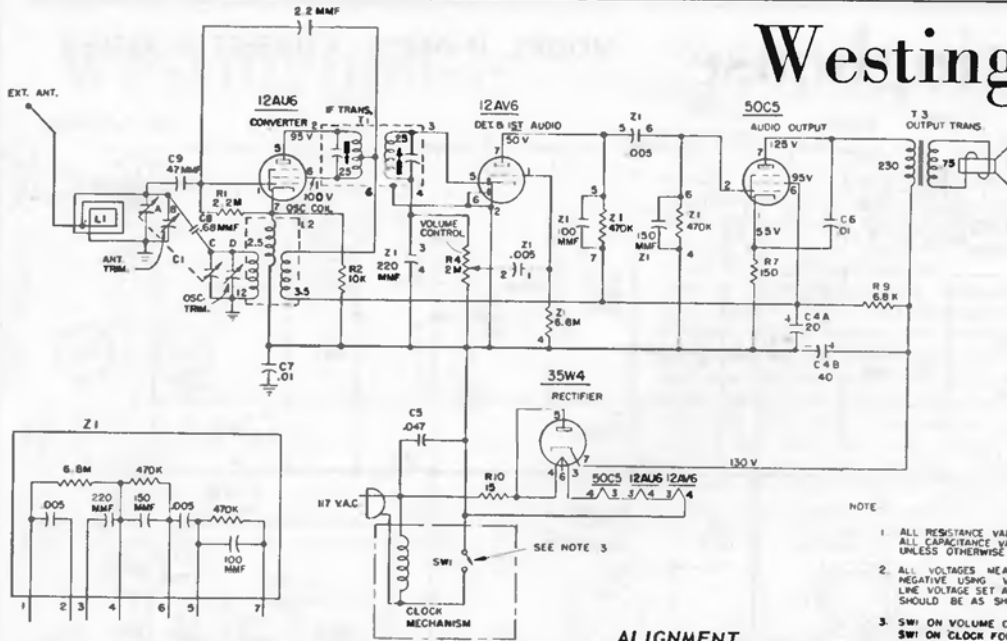

- NOTE
1. ALL RESISTANCE VALUES IN OHMS & ALL CAPACITANCE VALUES IN MMF UNLESS OTHERWISE SPECIFIED.
  2. ALL VOLTAGES MEASURED FROM COMMON NEGATIVE USING V.T.V.M. LINE VOLTAGE SET AT 117 V.A.C. READINGS SHOULD BE AS SHOWN  $\pm 20\%$ .
  3. SW1 ON VOLUME CONTROL FOR V2239-1,3 SW1 ON CLOCK FOR V2239-2,4

### ALIGNMENT

Step	Connect Signal Generator to -	Signal Generator Frequency	Radio Dial	Connect V.T.V.M. Across Voice Coil and Adjust for Maximum Output -
1	Stator of ant. tuning capacitor (A) through a 200 mmf capacitor	455 kc.	minimum capacity	Top and bottom slugs of T1
2	Radiated signal	1625 kc.	minimum capacity	Oscillator trimmer (D)
3	Radiated signal	1400 kc.	1400 kc.	Antenna trimmer (B)

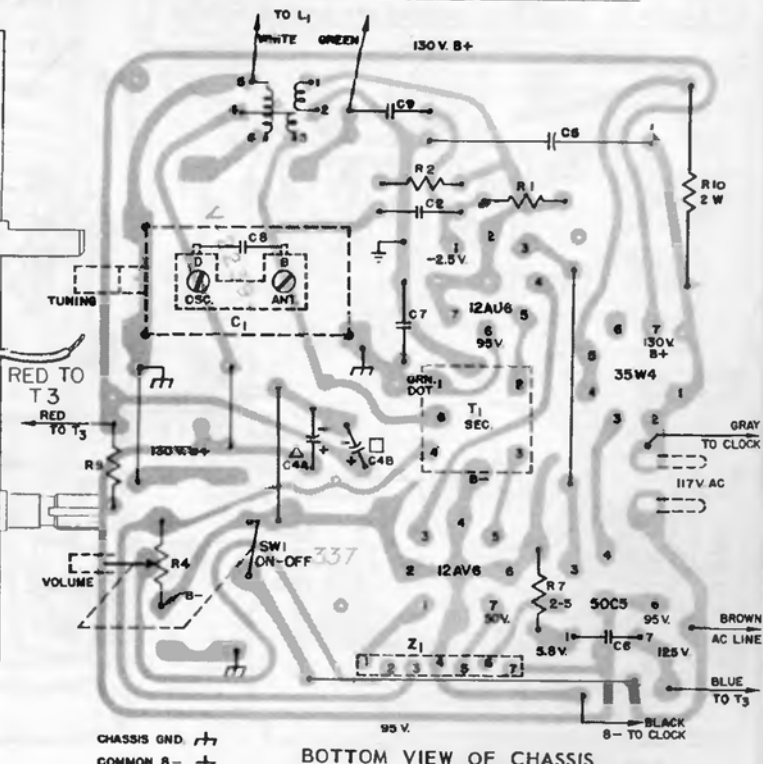
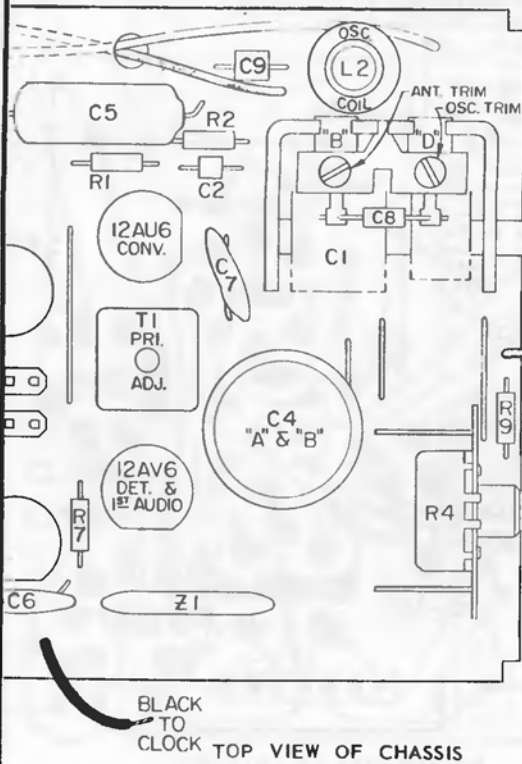

# Westinghouse

MODEL H-648T4, CHASSIS V-2239-5

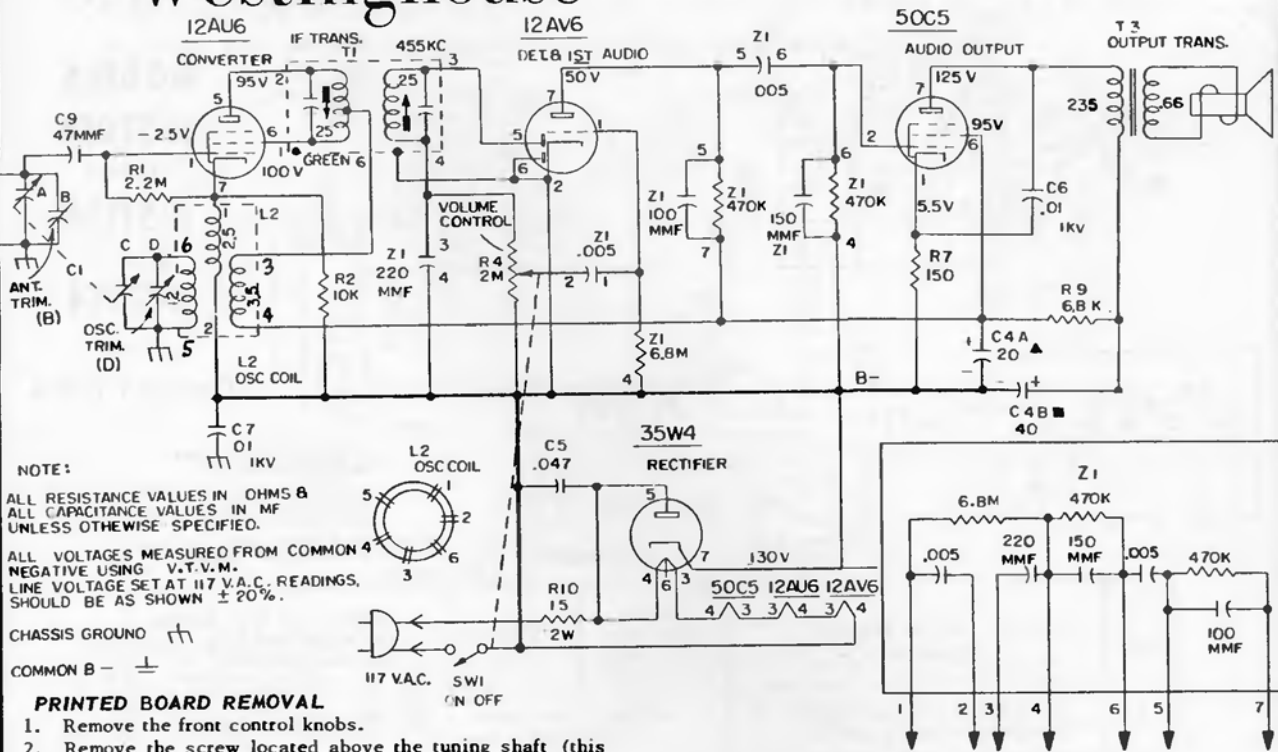

**NOTE:**  
ALL RESISTANCE VALUES IN OHMS &  
ALL CAPACITANCE VALUES IN MF  
UNLESS OTHERWISE SPECIFIED.

ALL VOLTAGES MEASURED FROM COMMON  
NEGATIVE USING V.T.V.M.  
LINE VOLTAGE SET AT 117 V.A.C. READINGS  
SHOULD BE AS SHOWN ± 20%.

CHASSIS GROUND

COMMON B -

### PRINTED BOARD REMOVAL

1. Remove the front control knobs.
2. Remove the screw located above the tuning shaft (this screw mounts the printed circuit board to the front of the cabinet).
3. Remove the two self-tapping screws from the back of the cabinet.
4. Remove the back cover. Be careful not to break the two leads from the antenna loop to the chassis.
5. Loosen the metal band securing the speaker leads to

6. Carefully slide the printed board out from the rear of the cabinet (the printed board is held secure in the cabinet by a top and bottom channel molded into the cabinet).
7. Use a conventional TV AC interlock line cord to power the radio while servicing.

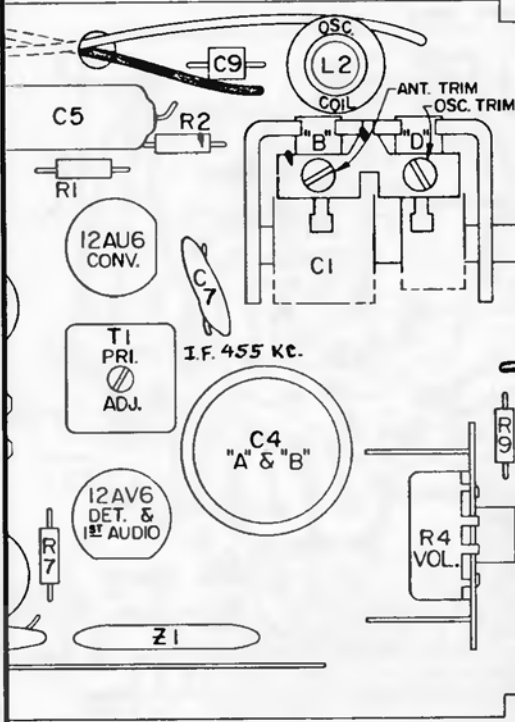

TOP VIEW OF CHASSIS

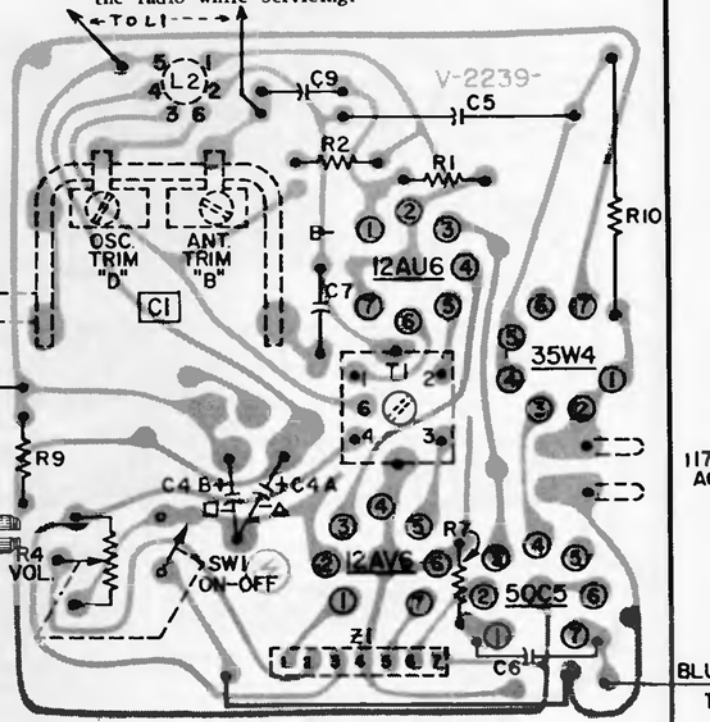

BOTTOM VIEW OF CHASSIS

# Westinghouse

Chassis V-2278-4 used in  
Models H-651P6, H-652P6, H-653P6

### BOARD REMOVAL

1. Remove the screw located in center of the tuning knob. Turn the dial to the low frequency end and grip the tuning knob with one hand. Remove the screw by turning it in a counter clockwise direction. Do not cause any undue strain on the tuning capacitor.
2. Remove back of cabinet by loosening coin-slot screw on back. Remove the 1/4" self tapping screw located at tuning condenser end of board.
3. Hold radio in the palm of the hand with the open back side up. Grip the board with the other hand and slide it down towards the tuning capacitor end of the cabinet, until the upper end of the speaker bracket is free of the plastic lip. Now raise this end of the bracket over lip and slide it out of the cabinet.
4. To insert the board into the cabinet use the reverse procedure, being careful to lock the speaker bracket under both recesses provided in the cabinet front.

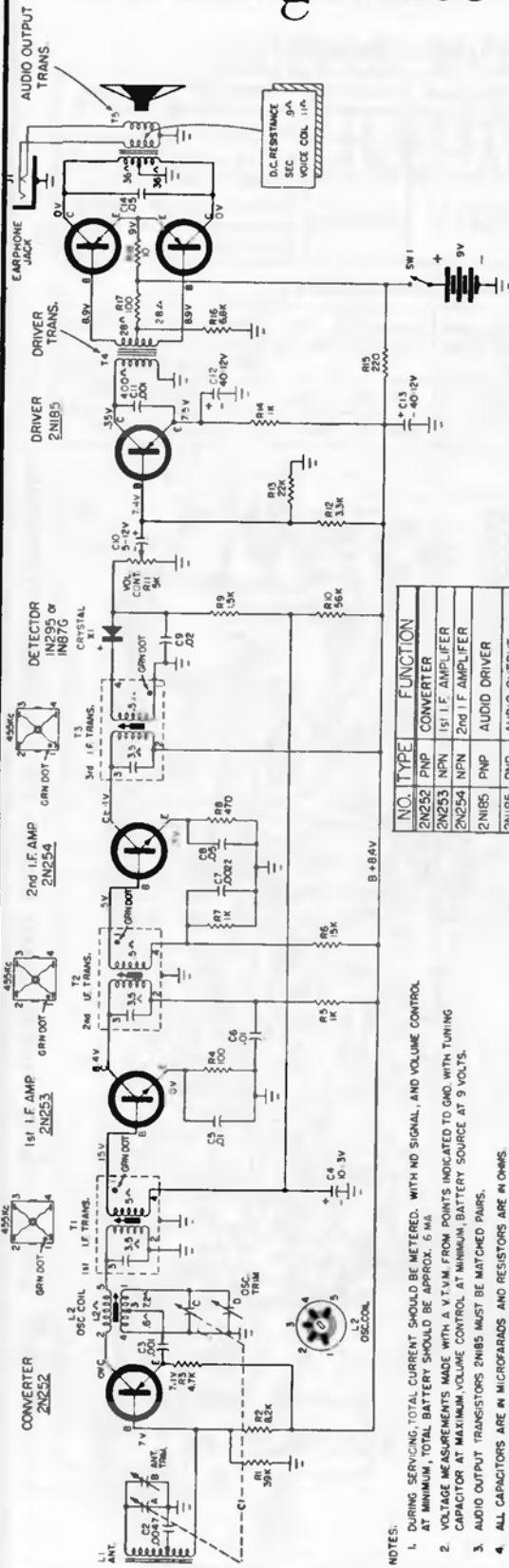

- NOTES:
1. DURING SERVICING, TOTAL CURRENT SHOULD BE METERED. WITH NO SIGNAL, AND VOLUME CONTROL AT MINIMUM, TOTAL BATTERY SHOULD BE APPROX. 6 MA.
  2. VOLTAGE MEASUREMENTS MADE WITH A V.T.M. FROM POINTS INDICATED TO GND. WITH TUNING CAPACITOR AT MAXIMUM, VOLUME CONTROL AT MINIMUM, BATTERY SOURCE AT 9 VOLTS.
  3. AUDIO OUTPUT TRANSISTORS 2N185 MUST BE MATCHED PAIRS.
  4. ALL CAPACITORS ARE IN MICROFARADS AND RESISTORS ARE IN OHMS.

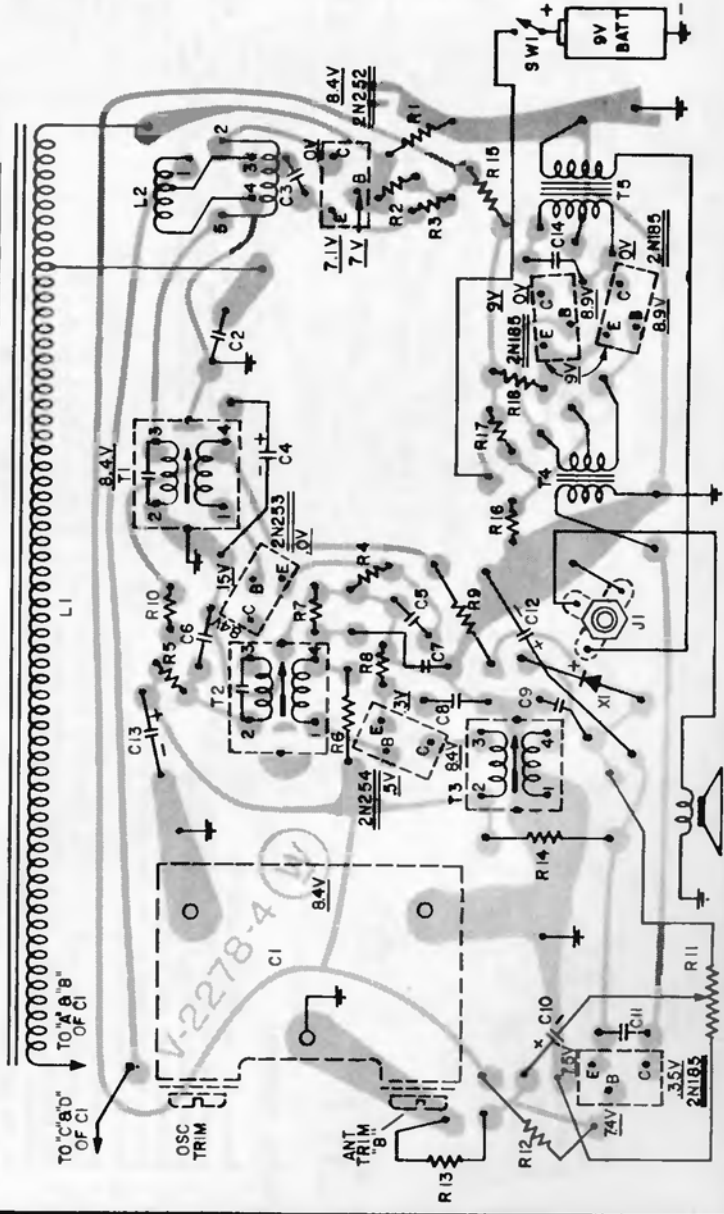

BOTTOM VIEW OF PRINTED CIRCUIT BOARD SHOWING COMPONENTS SYMBOLICALLY

# Westinghouse

Models H-621P6, H-622P6,  
Chassis V-2296-1

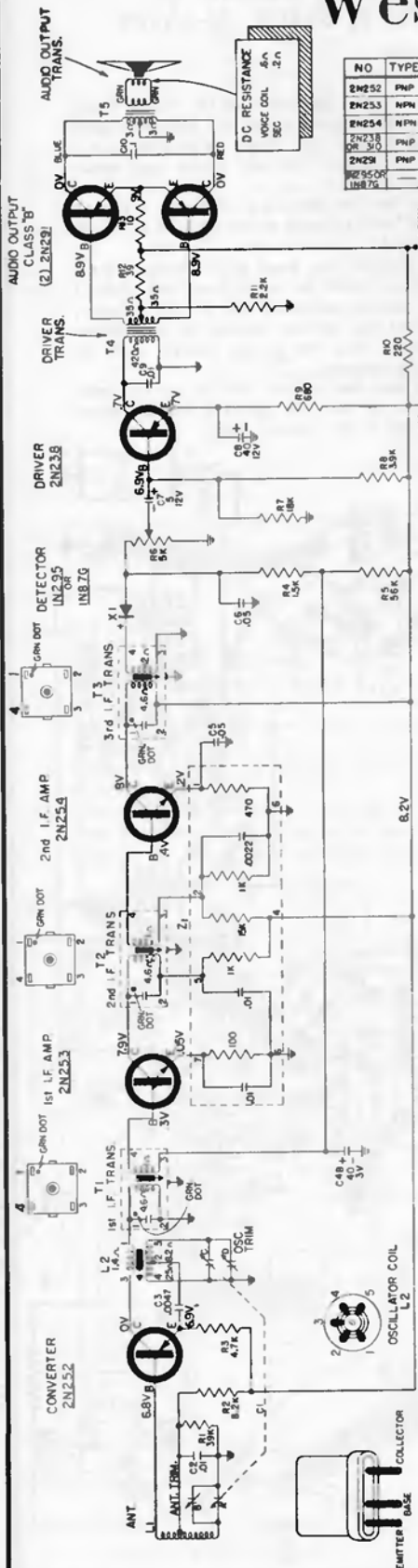

NO	TYPE	FUNCTION
2N252	PNP	CONVERTER
2N253	NPN	I.F. AMPLIFIER
2N254	NPN	I.F. AMPLIFIER
2N238	PNP	AUDIO DRIVER
2N291	PNP	AUDIO OUTPUT
IN295 OR INB7G	—	DETECTOR

### IF ALIGNMENT REQUIREMENTS

Loosely couple signal modulated from the generator to:	Generator Frequency	Connect VTVM or output meter across the voice coil and adjust:
Loop L1	455 KC	T3, T2, and T1 in order indicated for max. output (Reduce generator output if necessary for T2 and T1 adjustments.)*

### RF ALIGNMENT REQUIREMENTS

Loosely couple modulated signal, from generator to:	Generator Frequency	C1 Setting	Connect VTVM or output meter across voice coil and adjust for max. output
Loop L1	1625 KC	Min.	Oscillator Trim "D"
" "	1400 KC	1400 KC	Antenna Trim "B"

NOTES:  
1. DURING SERVICING, TOTAL BATTERY CURRENT SHOULD BE METERED. VOLUME CONTROL AT MINIMUM. TOTAL BATTERY DRAIN SHOULD BE APPROX. 10 MA.  
2. VOLTAGE MEASUREMENTS MADE WITH A V.T.V.M. FROM POINTS INDICATED IN DIAGRAM.  
3. AUDIO OUTPUT TRANSISTORS (2N291) MUST BE MATCHED PAIRS. TUNING CAPACITOR AT MAXIMUM. VOLUME CONTROL AT MINIMUM. BATTERY SOURCE AT 9 VOLTS.  
4. ALL CAPACITORS ARE IN MICROFARADS AND RESISTORS ARE IN OHMS.

- ### BOARD REMOVAL
1. Remove the two control knobs.
  2. Remove the three self tapping screws which secure the printed board to the interior of the cabinet.
  3. Disconnect the two pronged plug from either the receptacle in the top cover or from the battery pack.
  4. The radio chassis may now be removed from the cabinet for servicing without unsoldering the speaker leads.
  5. When inserting the radio chassis into the cabinet use the reverse procedure, being careful to insert the un-reinforced side of the printed board into the grooves on the inside front of the cabinet and then secure with self-tapping screws.

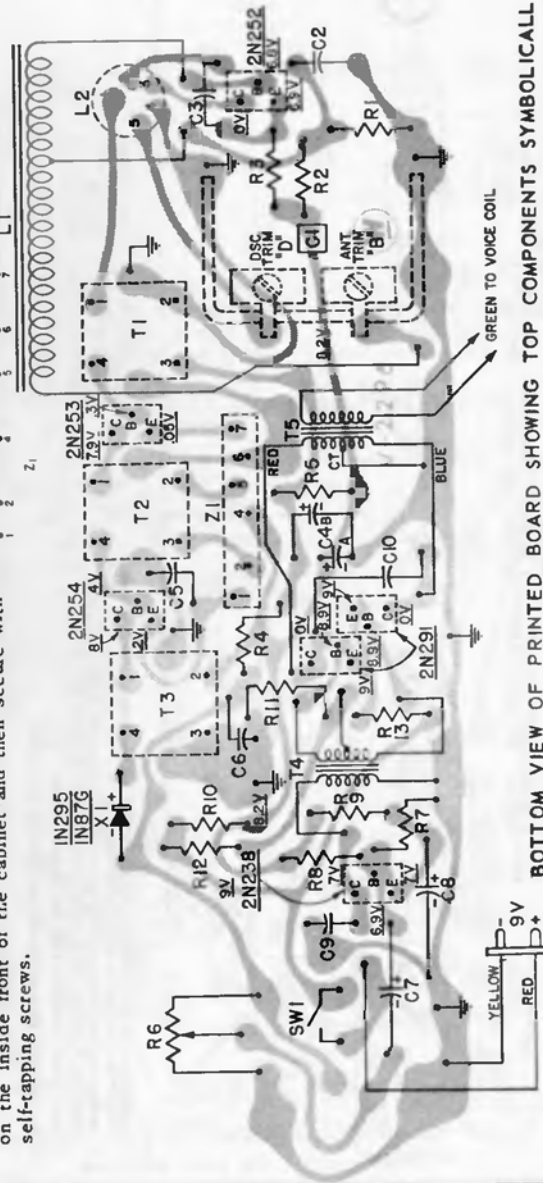

BOTTOM VIEW OF PRINTED BOARD SHOWING TOP COMPONENTS SYMBOLICALLY



# Westinghouse

## MODELS H-632T5 (MOCHA AND WHITE)

## H-633T5 (TURQUOISE AND WHITE)

### Chassis V-2390-1

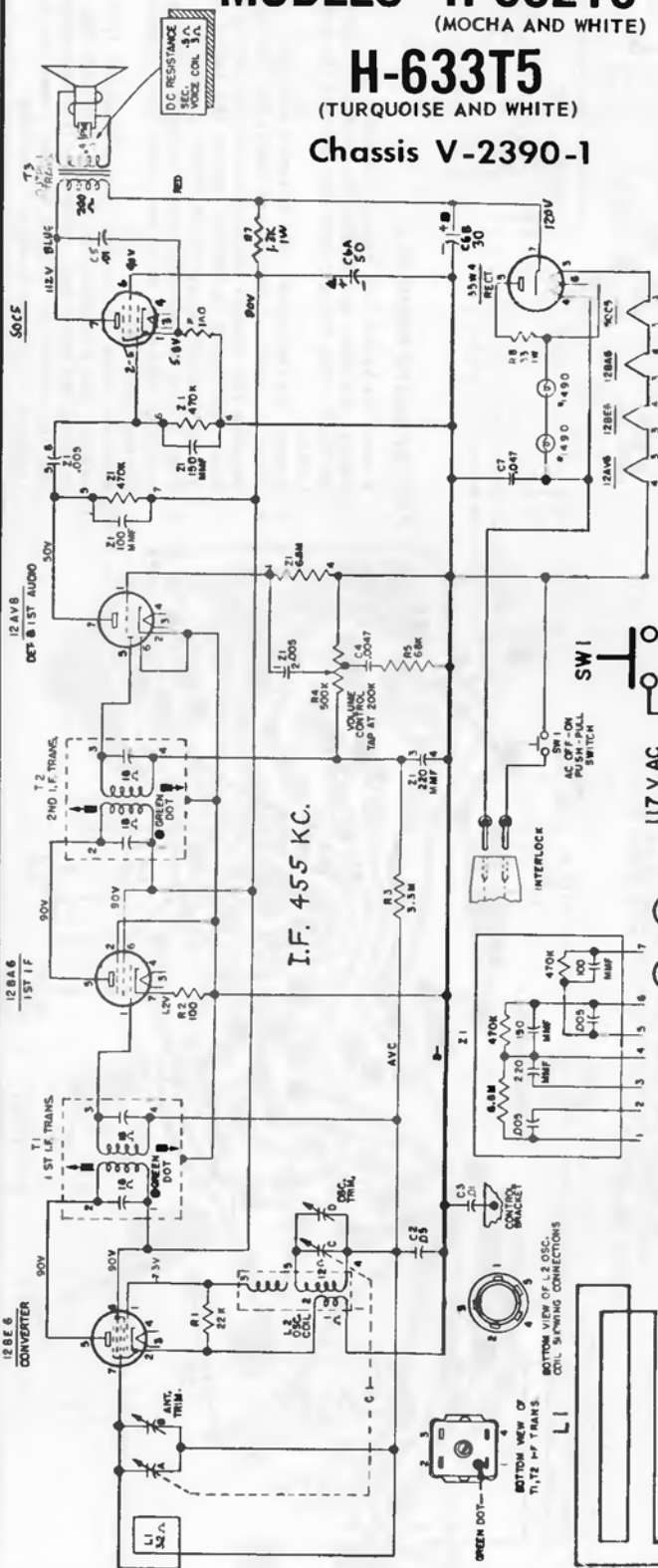

1. ALL VOLTAGES MEASURED FROM COMMON NEGATIVE USING A V.T.V.M. VOLUME CONTROL AT MINIMUM.  
 2. ALL CAPACITANCE VALUES IN MFD. & ALL RESISTANCE VALUES IN OHMS UNLESS OTHERWISE SPECIFIED.

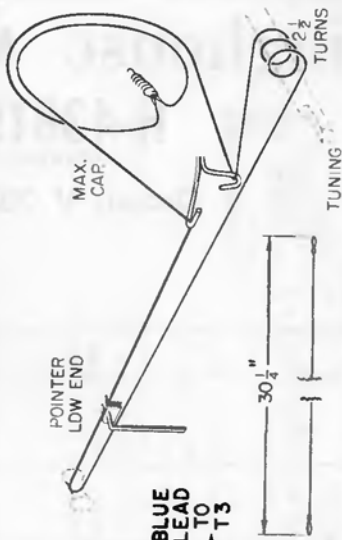

**PRINTED BOARD REMOVAL**  
 Remove the two 3/8" screws located at either end of the cabinet rear.  
 Remove the cabinet front from the cabinet back to expose the radio chassis. (The two 3/8" screws can be used to do this by pushing on both at same time after disengaging).  
 Use a conventional TV AC interlock line cord to power the radio while servicing.

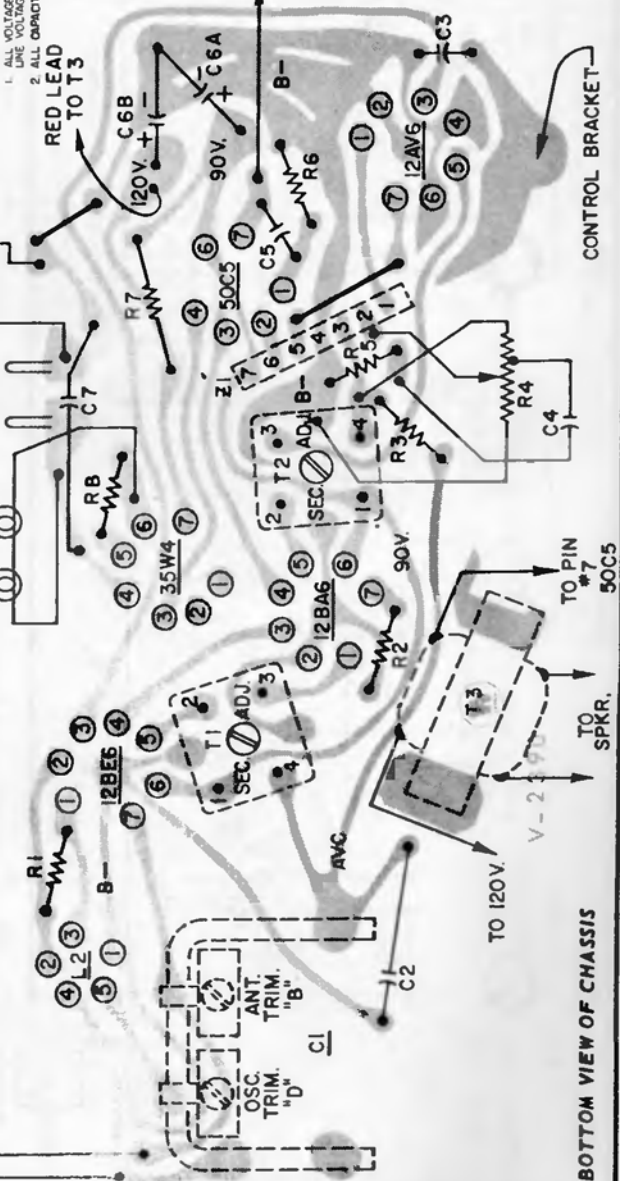

**BOTTOM VIEW OF CHASSIS**

# Westinghouse MODELS H-435T5A, H-437T5A, H-438T5A

(IVORY)

(TAN)

## H-438T5A

(GREEN)

Chassis V-2390-3

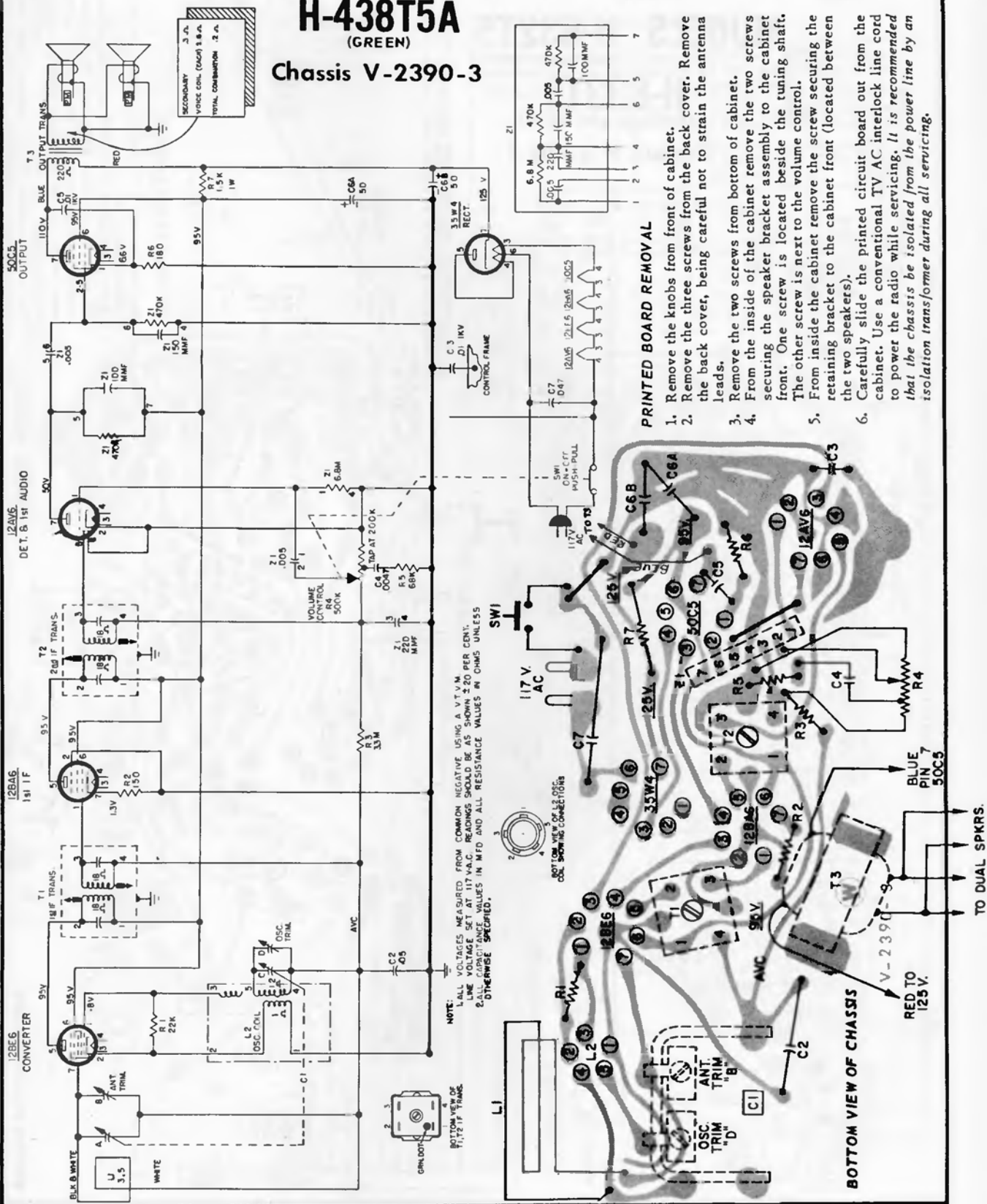

### PRINTED BOARD REMOVAL

1. Remove the knobs from front of cabinet.
2. Remove the three screws from the back cover. Remove the back cover, being careful not to strain the antenna leads.
3. Remove the two screws from bottom of cabinet.
4. From the inside of the cabinet remove the two screws securing the speaker bracket assembly to the cabinet front. One screw is located beside the tuning shaft. The other screw is next to the volume control.
5. From inside the cabinet remove the screw securing the retaining bracket to the cabinet front (located between the two speakers).
6. Carefully slide the printed circuit board out from the cabinet. Use a conventional TV AC interlock line cord to power the radio while servicing. It is recommended that the chassis be isolated from the power line by an isolation transformer during all servicing.



# Westinghouse

Models HF100BN, HF101BN,  
Chassis V-2500-1

## CIRCUIT INFORMATION

The V 2500-1 amplifier circuit, used in models HF100BN and HF101BN, is shown in figure 2.

An audio signal of about .7 volts is amplified to about 6 watts through a straightforward amplifier circuit. A 12AX7 serves as audio amplifier and phase inverter to drive the 6V6 push-pull output tubes. This output stage is operated class AB<sub>1</sub>.

Degeneration, for improved fidelity, is obtained through the use of unbypassed cathode resistors and the inverse feedback loop through R116.

A 2.7 ohm resistor is used in series with the 6AU6 heater to reduce hum.

The impedance of each speaker voice coil is 12.8 ohms. If a replacement speaker is required, use the correct Westinghouse replacement speaker listed in the parts list.

When operating the amplifier with speakers disconnected (during tests), connect four 50 ohm, 2 watt resistors in parallel across output terminals 2 and 4.

The function of C107 is to pass only high frequencies to the parallel high frequency speakers.

AC input (to the power transformer primary) is connected to 1 and 3 of the socket, SO 100; the AC on-off switch is located on the record changer.

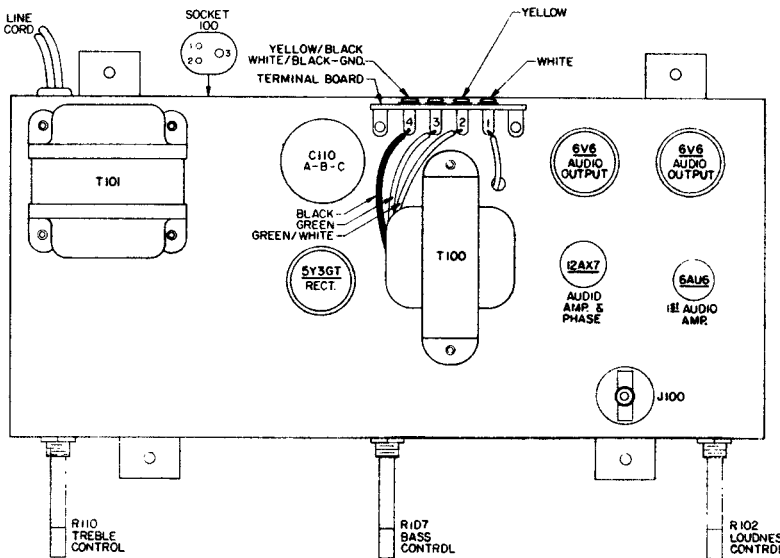

## VOLTAGE GAIN MEASUREMENTS

An audio signal generator and VTVM are required for voltage gain measurements. To measure over-all amplifier gain, proceed as follows: 1) Disconnect speaker. Connect four 50 ohm, 2 watt resistors in parallel across terminals 2 and 4. 2) Set loudness control, R102, to maximum loudness. 3) Set bass control, R107, and treble control, R110, to mid-range. 4) Connect generator output to J100. Set generator for 1Kc, at about .7 volts output. 5) Connect VTVM across output terminals 2 and 4. Approximate correct voltage reading is 8 volts.

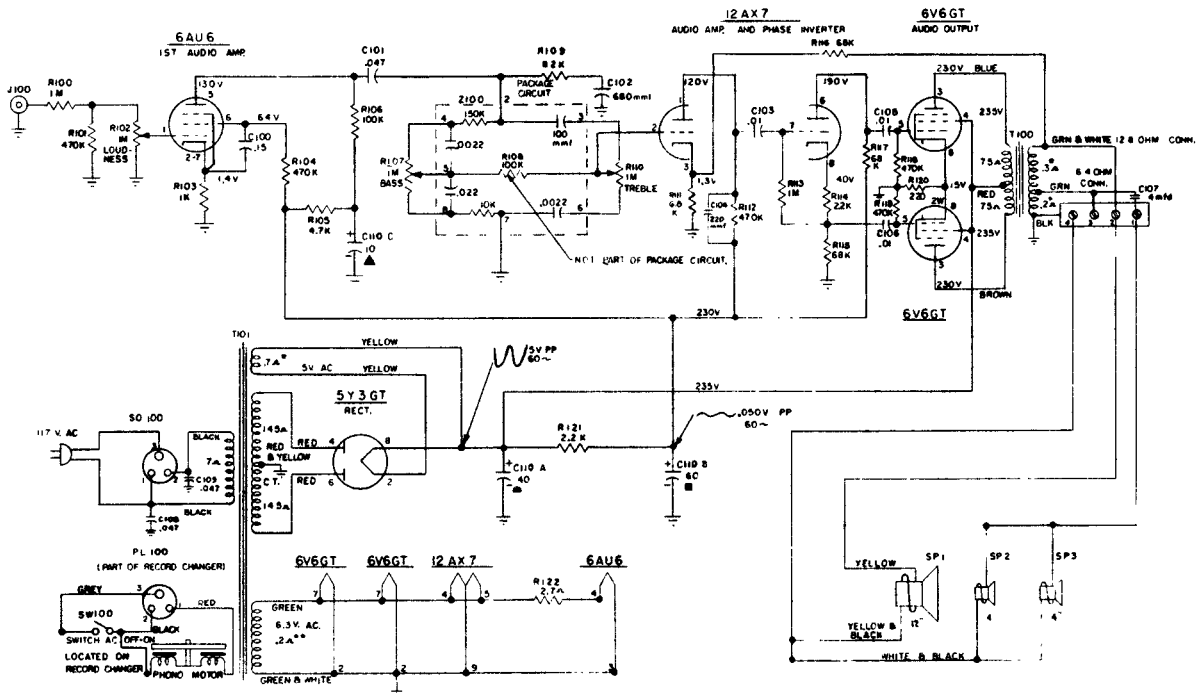

# Westinghouse

Models HF104DP, HF105DP, HF106DP,  
Chassis V-2501-1

## AMPLIFIER CIRCUIT INFORMATION

### Input

Two input jacks, J100A and J100B, are provided. SW100 selects the input signal fed to the 12AU6 1st audio amplifier. The output from the phono pick-up is fed to J100B; other audio signals may be fed to J100A.

### 1st audio amplifier

To minimize hum, the first audio amplifier heater receives direct current, fed from the cathode circuit of the push-pull output stage. R101 is unbypassed to provide degeneration for improved fidelity.

### Equalizer

Package circuit Z101 contains the record equalization capacitors and resistors. Equalization is selected by SW101 to modify the amplifier response, adapting the response to the type of record being played. Equalization positions are as follows:

RIAA: Compensates for RIAA recording curve.

LP: Compensates for standard 33 1/3 RPM records.

EUR: In this position, Z101 is switched out of the circuit. European records usually require this setting.

78: Compensates for older 78 RPM records.

### Tone controls

Except for R106, the tone control fixed resistors and capacitors are contained within packaged circuit Z100. Tone control characteristics are as follows:

BASS: Provides up to 20 db boost at 40 cycles.

TREBLE: Provides up to 15 db boost at 15,000 cycles.

### Audio amplifier and phase inverter stage

A 12AX7 is used as audio amplifier and phase inverter. Inverse feedback voltage is fed to the cathode of the audio amplifier (pin 3) to provide additional improvement in fidelity and stability. Grid drive to one 6L6 output tube is fed from the plate (pin 6); grid drive to the other 6L6 is fed from the junction of R111 and R112 in the cathode circuit of the phase inverter.

### Audio output stage

The 6L6 push-pull audio output tubes operate class AB<sub>1</sub>. R118 and R119 prevent oscillation (ringing). The 12AU6 heater serves as part of the common cathode resistor for the 6L6 tubes. (This circuit arrangement provides DC for the 12AU6 heater).

### Output circuit

Normal DC resistance across the primary and secondary of T100 is shown in figure 1. Output impedance, between terminals 2 and 4 is 12.8 ohms; impedance between terminals 3 and 4 is 6.4 ohms. C108 is the cross-over capacitor which passes the high frequencies to the paralleled high frequency speakers.

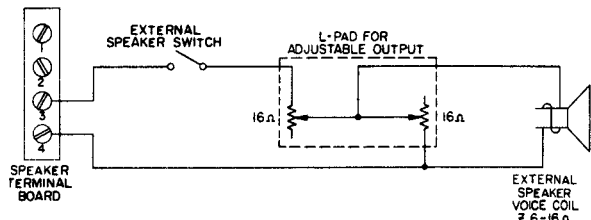

EXTERNAL SPEAKER CONNECTION,  
WITH SWITCH AND L PAD ATTENUATOR

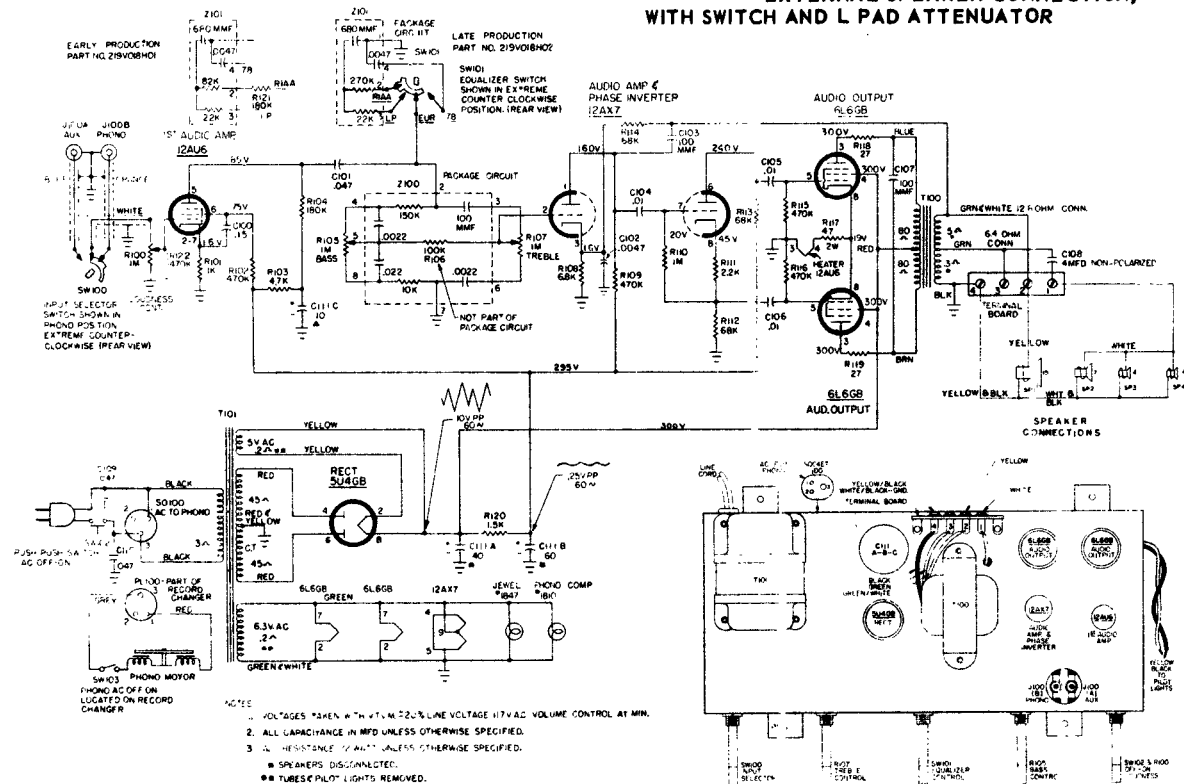

- NOTE:
- VOLTAGES \*GIVEN \*IN \*V.T.M. \*220V. \*LINE VOLTAGE \*117VAC. \*VOLUME CONTROL AT MIN.
  - ALL CAPACITANCE IN MFD UNLESS OTHERWISE SPECIFIED.
  - RESISTANCE IN OHMS UNLESS OTHERWISE SPECIFIED.
- SPEAKERS DISCONNECTED.  
• TUBES PILOT LIGHTS REMOVED.

# ZENITH RADIO MODEL A402 CHASSIS 4A41

**NOTES**  
 ALL VOLTAGES MEASURED FROM COMMON RETURN TO POINTS INDICATED WITH AN A.C.-D.C. OR VACUUM TUBE VOLTMETER.  
 ALL VOLTAGES ARE D.C. UNLESS OTHERWISE SPECIFIED.  
 ALL CONDENSERS ARE MICROFARADS UNLESS OTHERWISE SPECIFIED.  
 ALL CONDENSERS ARE ±20% TOLERANCE UNLESS OTHERWISE SPECIFIED.  
 ALL RESISTORS ARE ±20% TOLERANCE, 1/2 WATT, CARBON UNLESS OTHERWISE SPECIFIED.  
 USE ONLY ZENITH NON-INDUCTIVE ELECTROLYTIC CONDENSERS FOR REPLACEMENT.

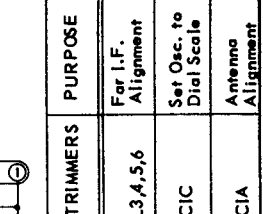
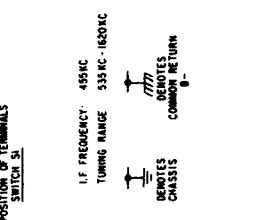
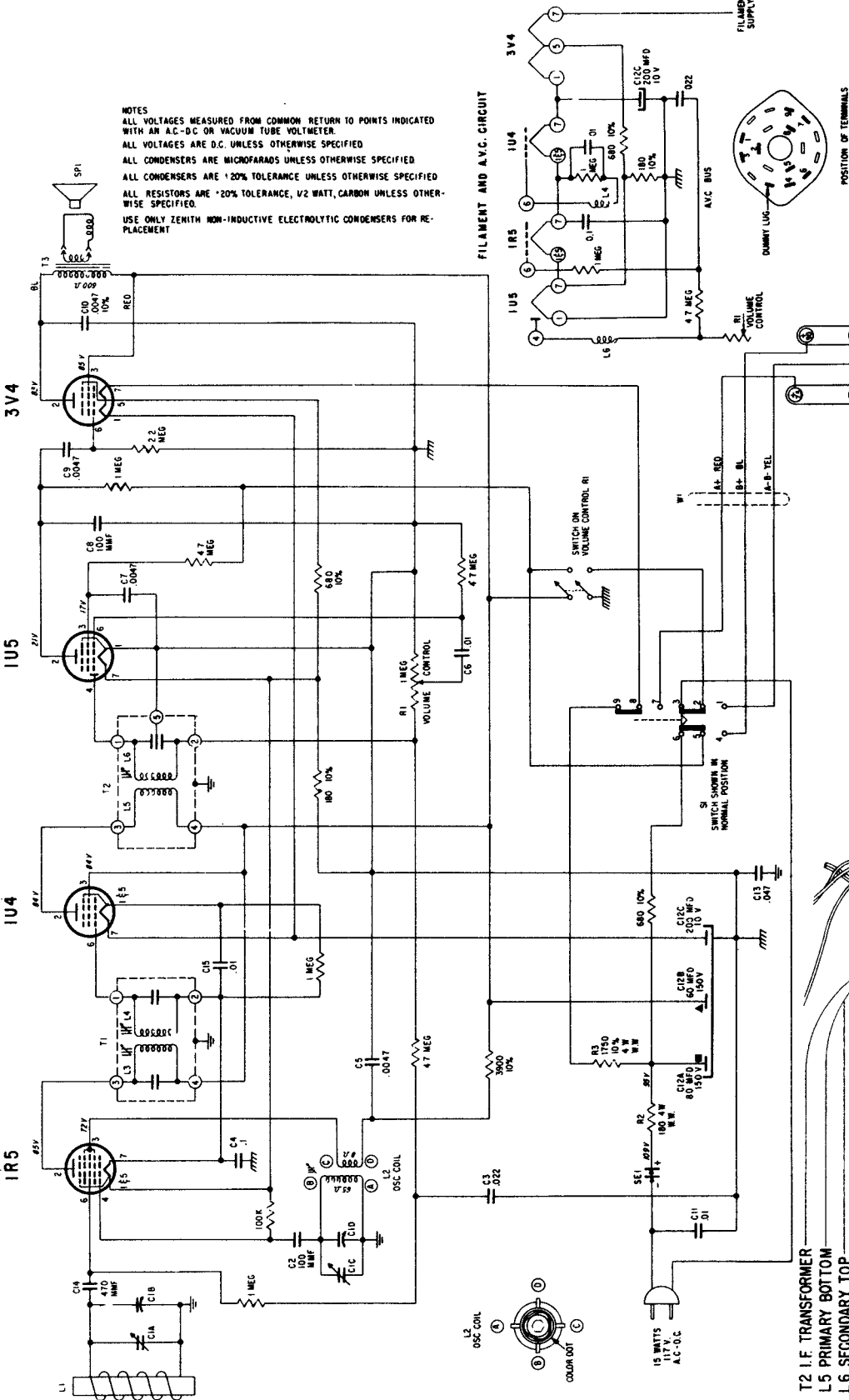

**ALIGNMENT PROCEDURE**

OPERATION	CONNECT OSC. TO	DUMMY ANT.	INPUT SIG. FREQUENCY	SET FREQUENCY	TRIMMERS	PURPOSE
1	Converter Grid	.5 mfd.	455 Kc.	600 Kc.	L3,4,5,6	Far I.F. Alignment
2	Single turn loosely coupled to WAVE MAGNET	—	1600 Kc.	1600 Kc.	CIC	Set Osc. to Dial Scale
3	—	—	1400 Kc.	1400 Kc.	CIA	Antenna Alignment

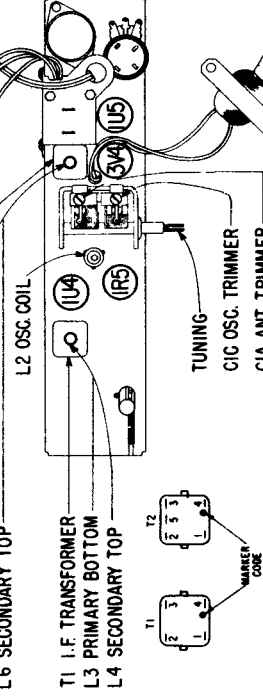

ANT. 33K U VIM TO UV  
 28K 600KC TO 455KC  
 33K 455KC TO 400V  
 15K AT 400V

# ZENITH RADIO MODEL A504 CHASSIS 5A41

35 UVW IN TO UV AT 60MC  
 30 X AT 600KC TO 455 IC  
 20 X 600KC TO 455 IC  
 6 X 455K TO 400V  
 84 X AT 400V  
 15 X AT 400V AT 50MW OUTPUT

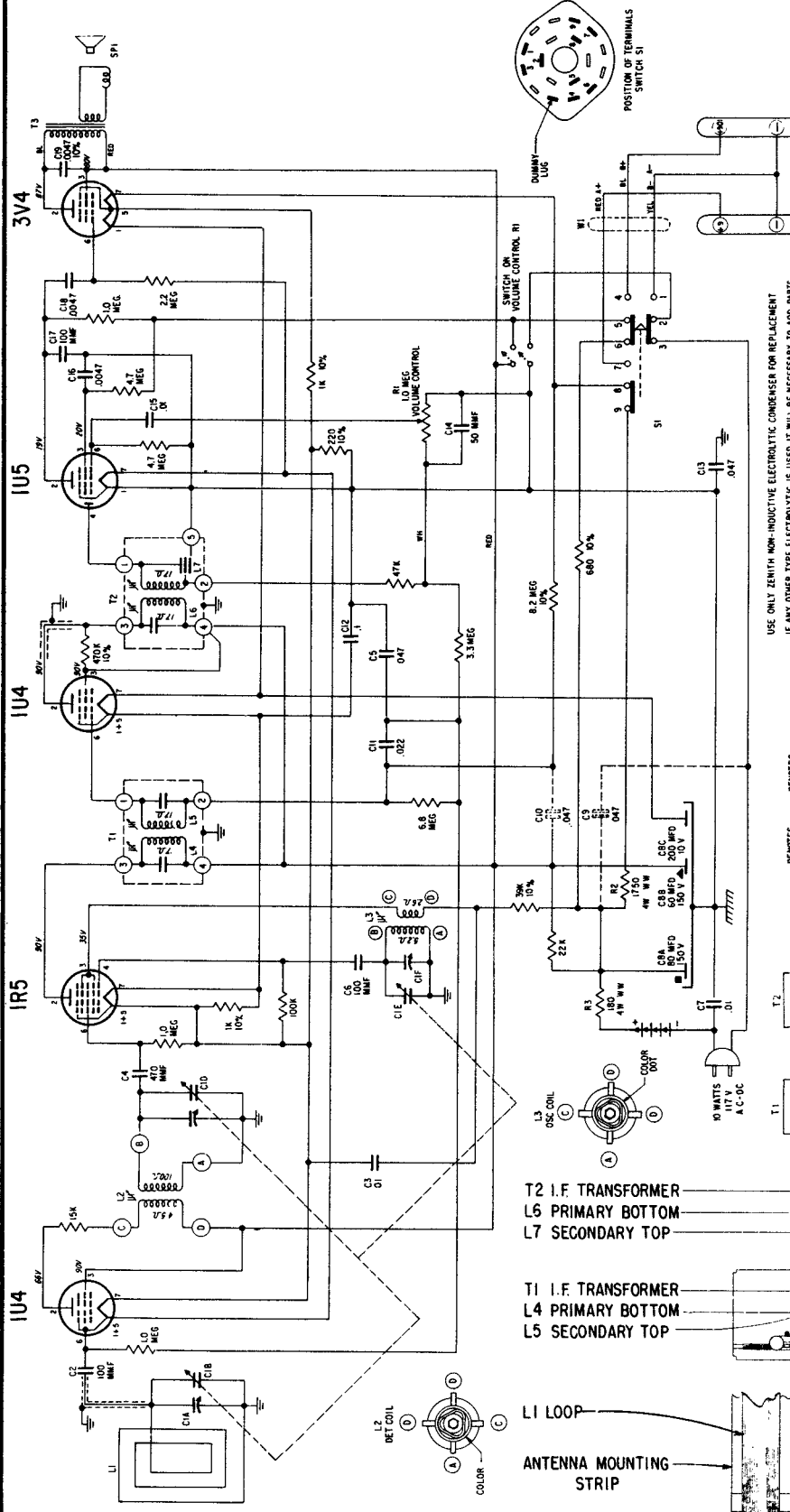

USE ONLY ZENITH NON-INDUCTIVE ELECTROLYTIC CONDENSER FOR REPLACEMENT  
 IF ANY OTHER TYPE ELECTROLYTIC IS USED, IT WILL BE NECESSARY TO ADD PARTS SHOWN IN DOTTED LINES  
 ALL VOLTAGES MEASURED FROM COMMON RETURN TO POINTS INDICATED WITH A DC VACUUM TUBE VOLTMETER  
 ALL RESISTORS ARE ±20% TOLERANCE, 1/2 WATT, CARBON UNLESS OTHERWISE SPECIFIED  
 ALL CAPACITORS ARE IN MICROFARADS UNLESS OTHERWISE SPECIFIED

### ALIGNMENT PROCEDURE

OPERATION	CONNECT OSC. TO	DUMMY ANT.	INPUT SIG. FREQUENCY	SET DIAL AT	TRIMMERS	PURPOSE
1	Converter Grid	.5 mfd.	455 Kc.	600 Kc.	L4,5,6,7	For I.F. Alignment
2	Single Turn Loosely Coupled to WAVE MAGNET	—	1600 Kc.	1600 Kc.	CIF	Set Osc. to Dial Scale
3	—	—	1400 Kc.	1400 Kc.	CID	Detector Alignment
4	—	—	1400 Kc.	1400 Kc.	CIB	Antenna Alignment

T2 I.F. TRANSFORMER  
 L6 PRIMARY BOTTOM  
 L7 SECONDARY TOP

T1 I.F. TRANSFORMER  
 L4 PRIMARY BOTTOM  
 L5 SECONDARY TOP

L1 LOOP  
 ANTENNA MOUNTING STRIP

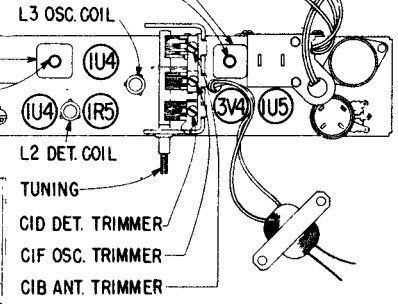

# Zenith Radio Corporation Model A555 Chassis 5A08

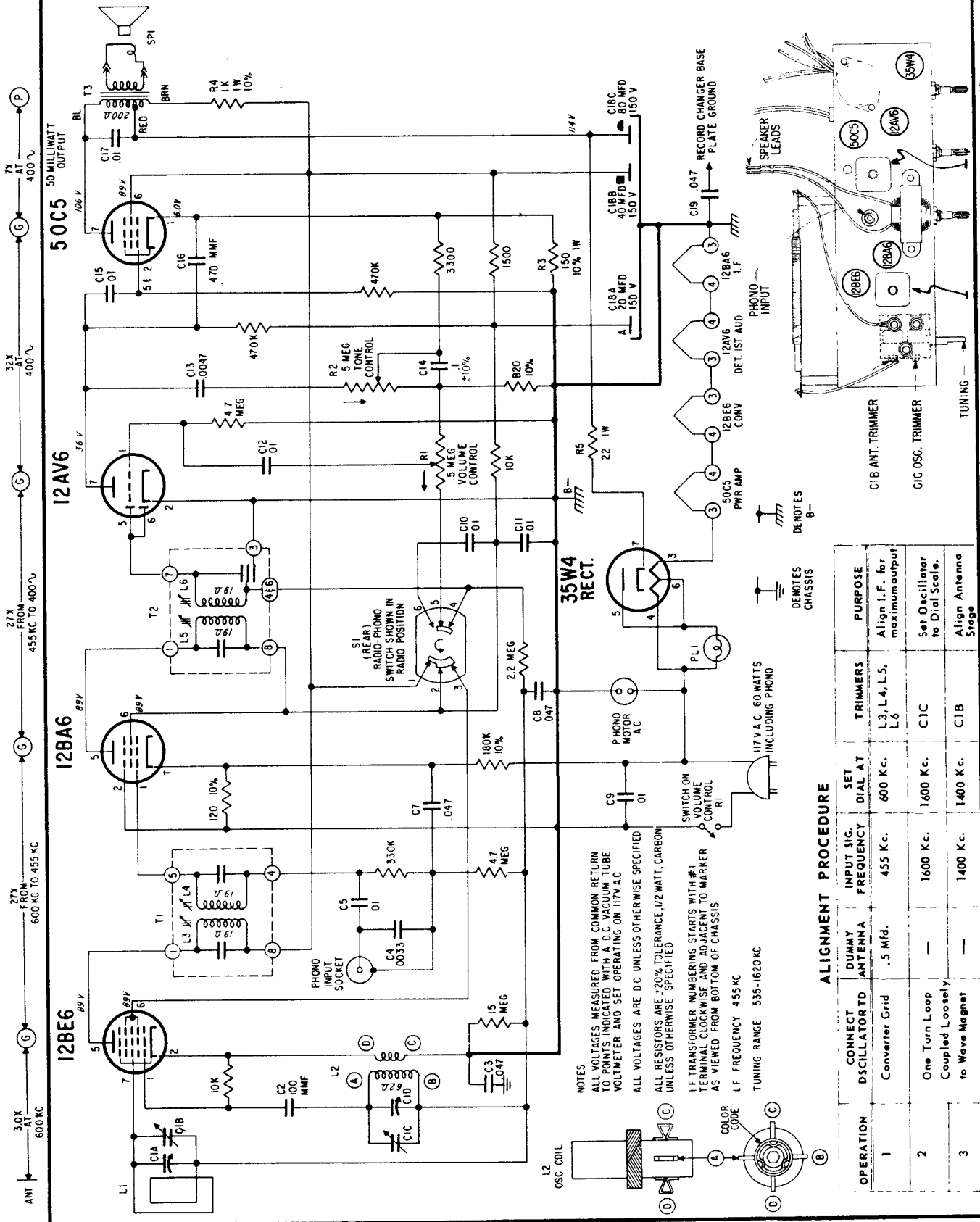

**NOTES**  
 ALL VOLTAGES MEASURED FROM COMMON RETURN TO POINTS INDICATED WITH A D.C. VACUUM TUBE VOLTMETER AND SET OPERATING ON 117V.A.C.  
 ALL VOLTAGES ARE DC UNLESS OTHERWISE SPECIFIED  
 ALL RESISTORS ARE ±20% TOLERANCE, 1/2 WATT, CARBON UNLESS OTHERWISE SPECIFIED  
 I.F. TRANSFORMER NUMBERING STARTS WITH #1 TERMINAL CLOCKWISE AND ADJACENT TO MARKER AS VIEWED FROM BOTTOM OF CHASSIS  
 L.F. FREQUENCY 455 KC  
 TUNING RANGE 535-1620 KC

**ALIGNMENT PROCEDURE**

OPERATION	CONNECT DSCILLATOR	DUMMY ANTENNA	INPUT SIG. FREQUENCY	SET DIAL AT	TRIMMERS	PURPOSE
1	Converter Grid	.5 Mfd.	455 Kc.	600 Kc.	L3, L4, L5, L6	Align I.F. for maximum output
2	One Turn Loop Coupled Loosely to Wave Magnet	—	1600 Kc.	1600 Kc.	C1C	Set Oscillator to Dial Scale.
3	—	—	1400 Kc.	1400 Kc.	C1B	Align Antenna Stage

T1 1ST I.F. TRANSFORMER  
 L3 PRIMARY BOTTOM  
 L4 SECONDARY TOP  
 T2 2ND I.F. TRANSFORMER  
 L5 PRIMARY BOTTOM  
 L6 SECONDARY TOP



ZENITH RADIO CORPORATION MODELS A624G, W & Y CHASSIS 6A03

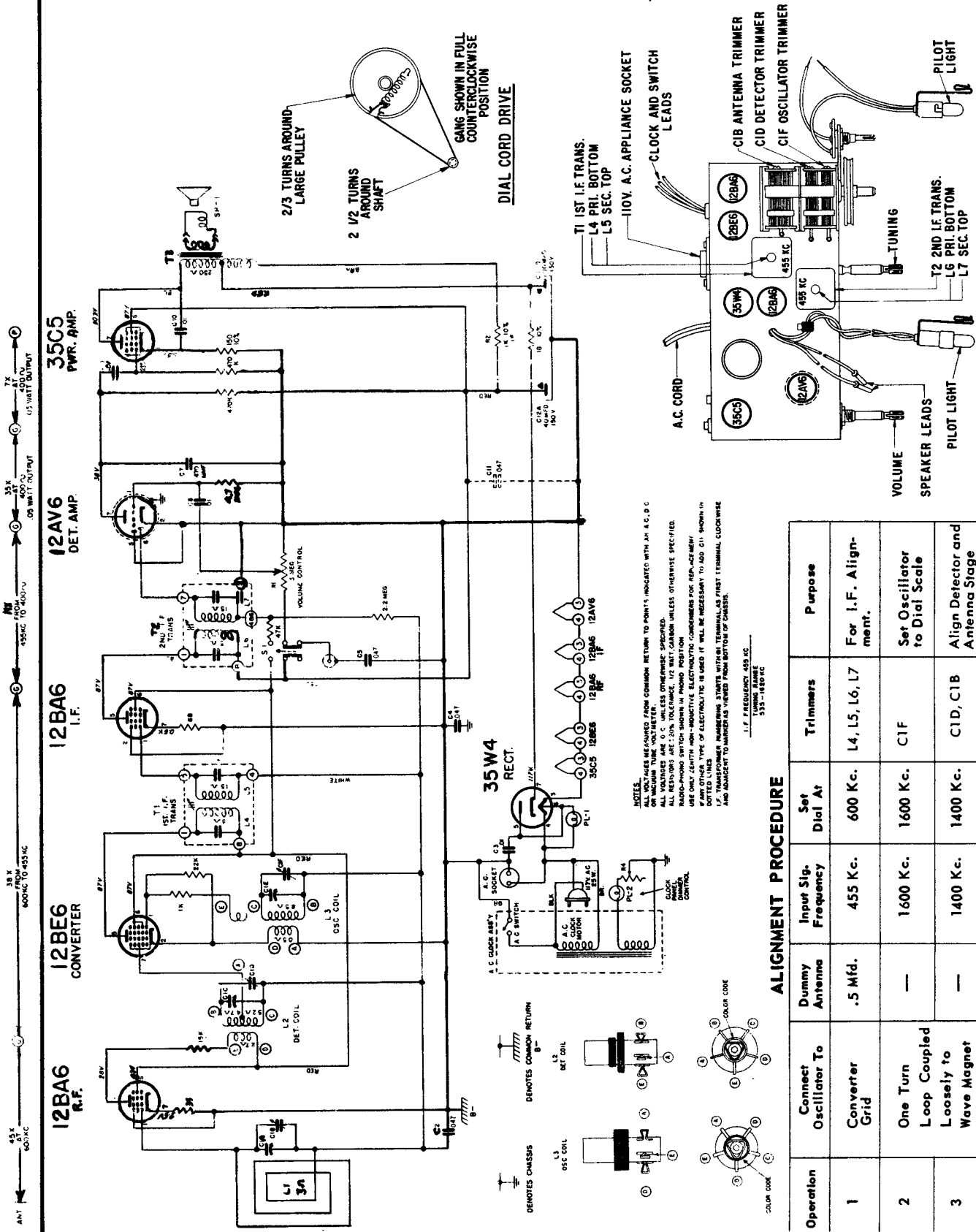

NOTES:  
 1. ALL VOLTAGES ARE BASED UPON COMMON RETURN TO POINTS INDICATED WITH AN A.C. G.C. OR MEDIUM TUBE FOOT METER.  
 2. ALL VOLTAGES ARE 0 C UNLESS OTHERWISE SPECIFIED.  
 3. ALL RESISTORS ARE 5% TOLERANCE, 1/2 WATT, CARBON UNLESS OTHERWISE SPECIFIED.  
 4. RADIO-PHONO SWITCH SHOWN IN PHONO POSITION.  
 5. IF ANY OTHER TYPE OF ELECTROLYTIC IS USED IT WILL BE NECESSARY TO ADD C.I.T. SHOWN IN DOTTED LINES.  
 6. I.F. TRANSFORMER NUMBERING STARTS WITH THE TERMINAL'S FIRST TERMINAL CLOCKWISE AND SUBJECT TO NUMBERS, VERIFIED FROM SERVICE OF CHASSIS.  
 I.F. FREQUENCY 455 KC  
 L.I.F. RANGE 535-1630 KC

ALIGNMENT PROCEDURE

Operation	Connect Oscillator To	Dummy Antenna	Input Sig. Frequency	Set Dial At	Trimmers	Purpose
1	Converter Grid	.5 Mfd.	455 Kc.	600 Kc.	L4, L5, L6, L7	For I.F. Alignment.
2	One Turn Loop Coupled Loosely to Wave Magnet	—	1600 Kc.	1600 Kc.	C1F	Set Oscillator to Dial Scale
3		—	1400 Kc.	1400 Kc.	C1D, C1B	Align Detector and Antenna Stage



ZENITH RADIO Models A730E, A730R,  
Chassis 7A05, Alignment Information  
(Continued from page 178, at left)

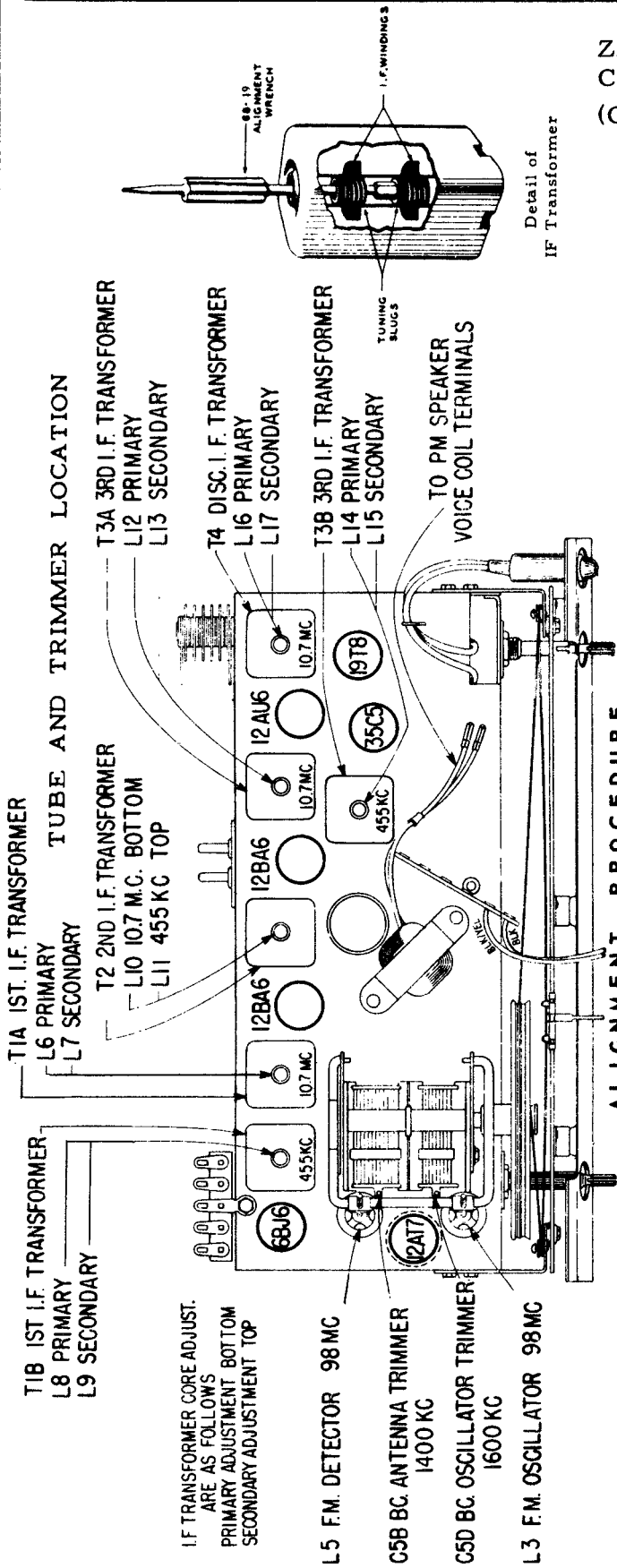

ALIGNMENT PROCEDURE

OPERATION	CONNECT OSCILLATOR TO	DUMMY ANTENNA	INPUT SIGNAL FREQUENCY	BAND	SET DIAL TO	ADJ. TRIMMERS	PURPOSE
1	Pin 2 12AT7 Converter	.05 Mfd.	455 Kc. Modulated.	BC	600 Kc.	L8, 9, 11, 14, 15	Align i.f. channel for maximum output.
2	2 turns loosely coupled to wavemagnet		1600 Kc. Modulated.	BC	1600 Kc.	C5D	Set oscillator to dial scale.
3	2 turns loosely coupled to wavemagnet		1400 Kc. Modulated.	BC	1400 Kc.	C5B	Align antenna stage
4 (a)	Pin 1 (grid) on 12AU6 limiter	.05 Mfd.	10.7 Mc. Unmodulated.	FM		L16 coil slug Primary discr.	Align primary of discriminator for maximum reading.
5 (b)	Pin 1 (grid) on 12AU6 limiter	.05 Mfd.	10.7 Mc. Unmodulated.	FM		L17 coil slug sec. of discr.	Adjust secondary of discriminator for zero reading.
6 (c)	Pin 1 (grid) on 12BA6 2nd IF.	.05 Mfd.	10.7 Mc. Unmodulated.	FM		L12 & L13 Prim. & Sec. of 3rd IF trans.	Align 3rd IF transformer for maximum reading.
7 (c)	Pin 1 (grid) on 12BA6 1st IF.	.05 Mfd.	10.7 Mc. Unmodulated.	FM		L10 Prim. of 2nd IF transformer.	Align 2nd IF transformer for maximum reading.
8 (c)	Pin 2 (grid) on 12AT7 converter tube socket	.05 Mfd.	10.7 Mc. Unmodulated.	FM		L6 & L7 Prim. & Sec. of 1st IF trans.	Align 1st IF transformer for maximum reading.
9 (c)	Antenna Post FM (Remove line ant.)	270 ohms	98 Mc. Unmodulated.	FM	98 Mc.	L3 Osc. Coil Slug	Set Oscillator to dial scale.
10 (c) (d)		270 ohms	98 Mc. Unmodulated.	FM	98 Mc.	L5 Det. Coil Slug	Align det. stage to maximum reading.

# ZENITH RADIO CORPORATION MODELS AP6B,J,V

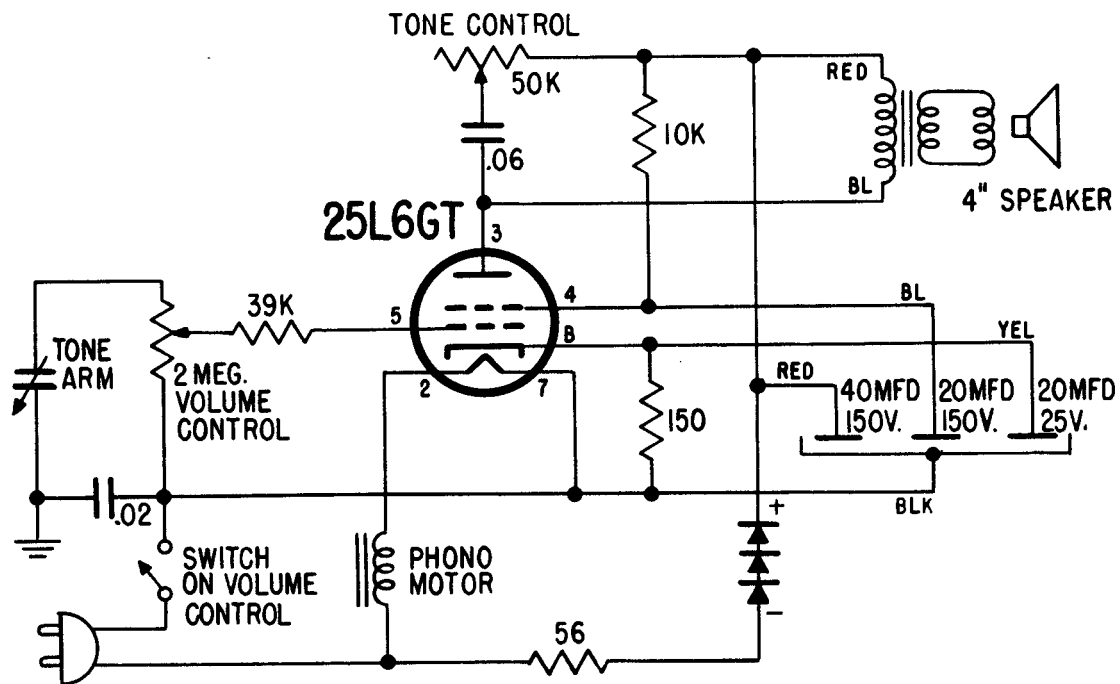

# MODEL AP9B

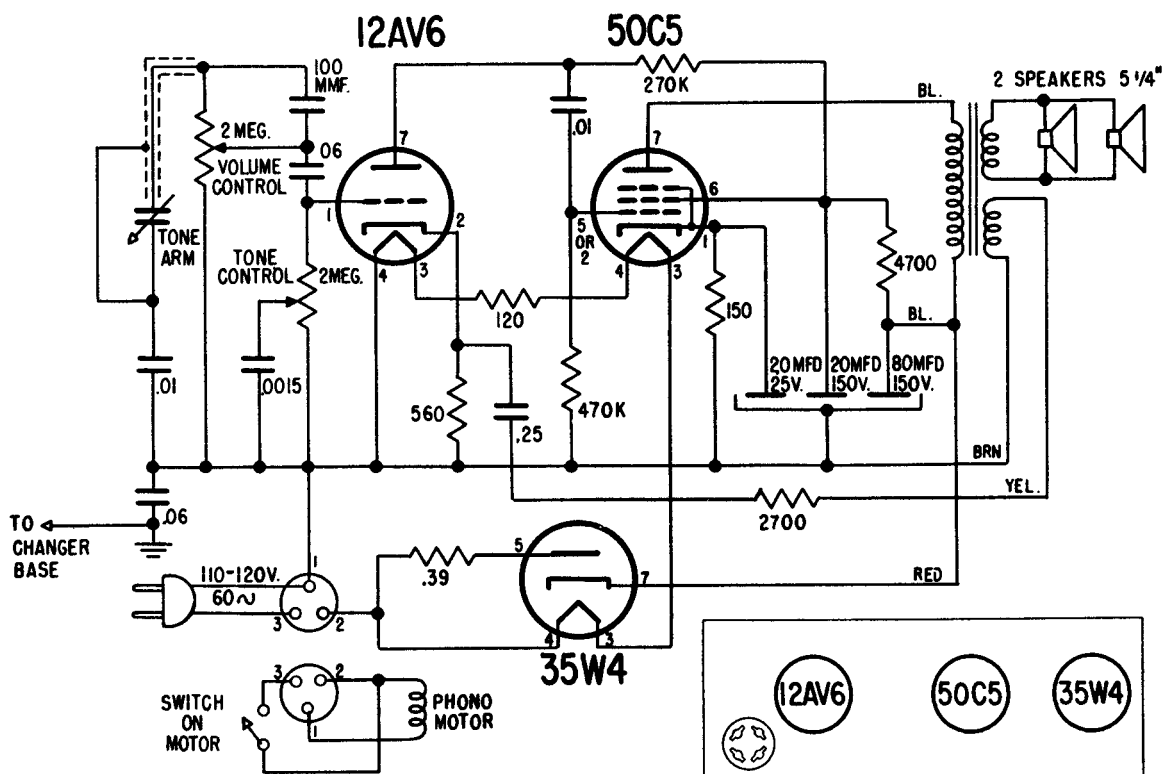

# ZENITH RADIO MODEL AP7F

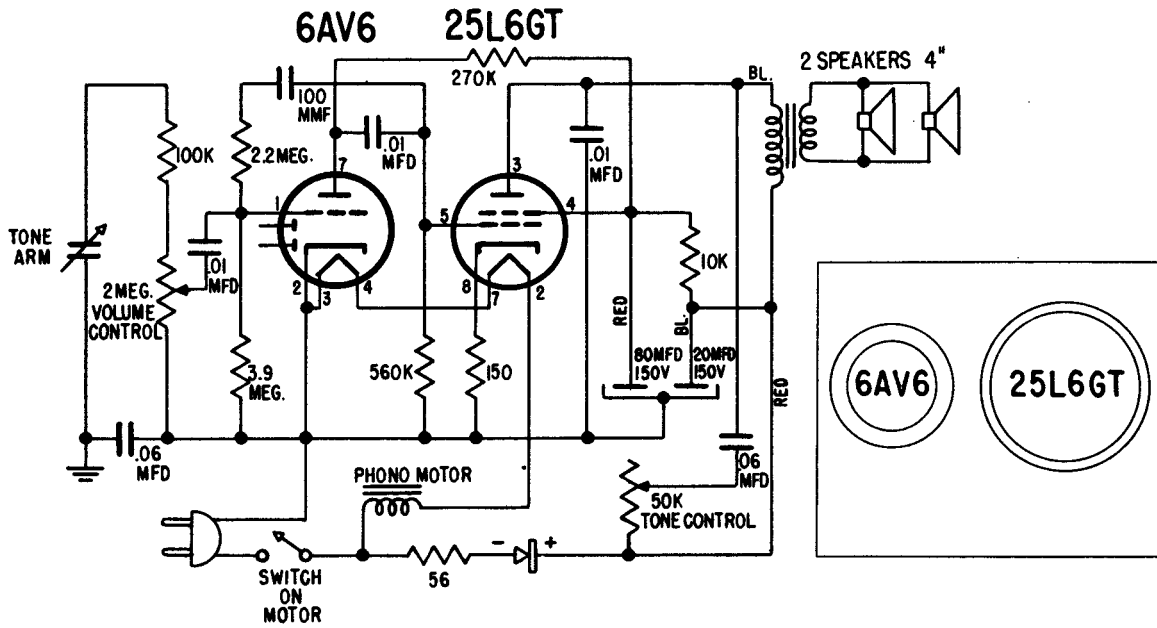

# MODEL AP8J

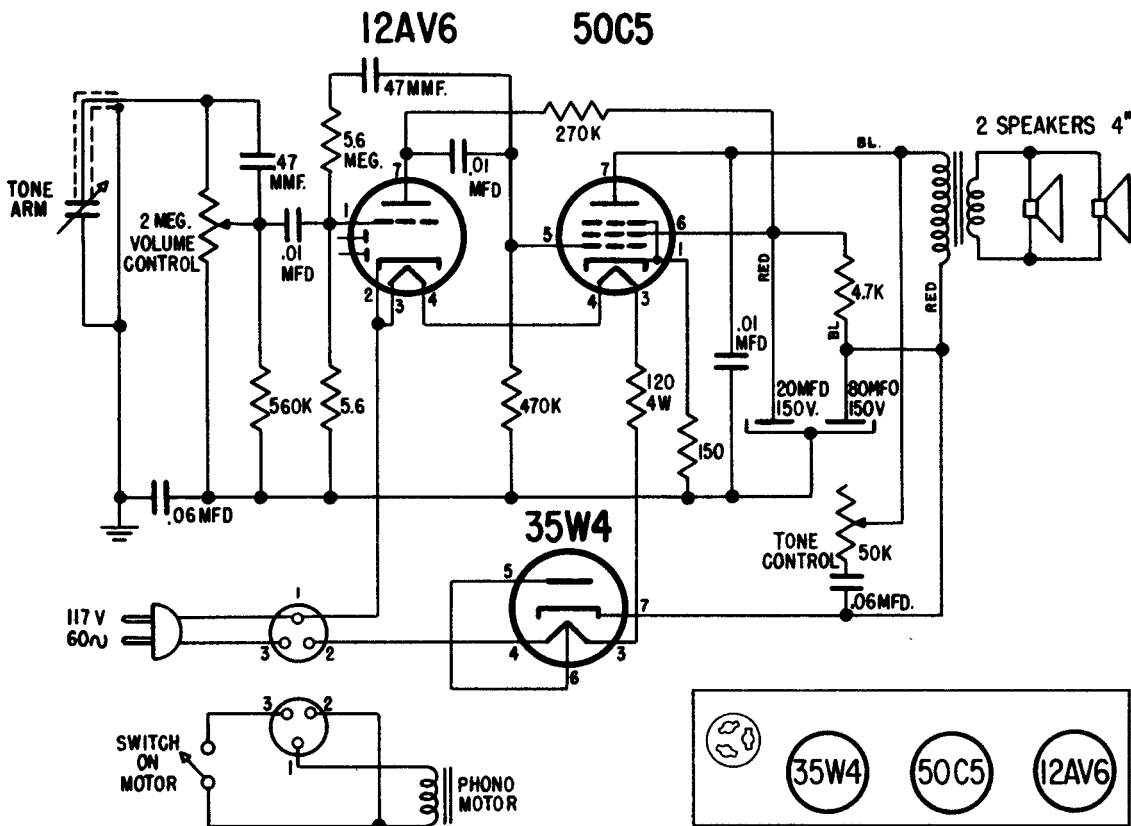

## ZENITH RADIO Chassis 7AT42 & 7AT42Z1

Model "Royal 300" (Continued on page 183)

### CHASSIS IDENTIFICATION

The "Royal 300" seven transistor portable has been produced with two basic chassis. This expedient was necessary to enable us to produce sufficient quantities by using transistors from several sources. Both chassis have the chassis number stamped on them as well as a color identifying code on the battery compartment just above the battery installation instruction label.

The 7AT42 chassis uses transistors manufactured by Sylvania. The 7AT42Z1 chassis uses transistors manufactured by Texas Instrument. In addition to this, both chassis have individual transistor layout labels. The color of the printing on these labels conforms respectively to the color dot on the chassis. The accompanying chart gives all the necessary information on chassis number, color dot, transistor layout labels, transistor numbers, Zenith part number, RETMA part number (where available), transistor supplier, etc.

Chassis	Chassis Color Dot	Transistor Layout Label Color	Part No.	Mixer	Osc.	1st. I.F.	2nd I.F.	Crystal Diode Detector	Driver	Output-Output	Supplier
7AT42	Green	Green 102-3498	Zenith RETMA Type	121-22 2N194 NPN	121-21 2N193 NPN	121-70 NPN	121-71 NPN	103-19 1N87G	121-7 2N35 NPN	121-8 2N35-2N35 Matched Pair NPN NPN	Sylvania
7AT42Z1	Red	Red 102-3474	Zenith Type	121-54 PNP	121-53 PNP	121-50 NPN	121-51 NPN	103-19 1N87G	121-52 PNP	121-19 Matched Pair PNP PNP	Texas Instrument

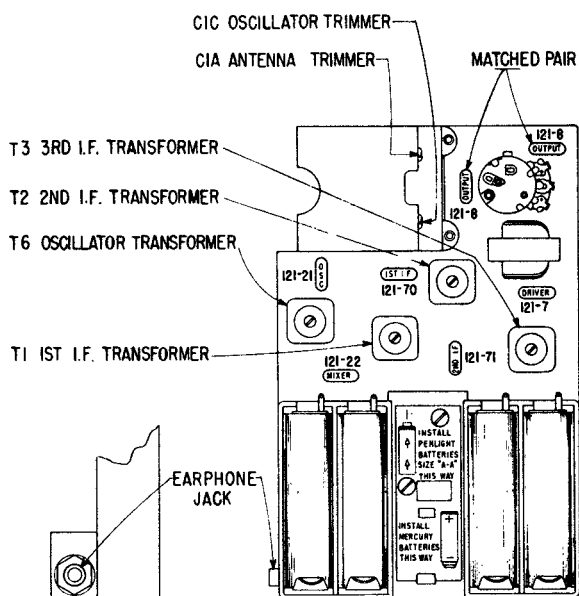

TRANSISTOR & TRIMMER LAYOUT FOR 7AT42

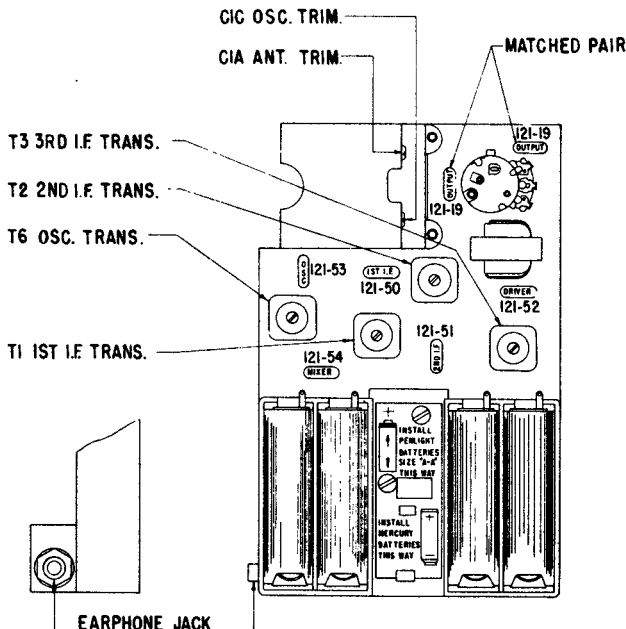

TRANSISTOR & TRIMMER LAYOUT FOR 7AT42Z1

## Alignment Procedure

Operation	Input Signal Frequency	Connect Inner Conductor From Oscillator To	Connect Outer Shield Conductor From Oscillator To	Set Dial At	Trimmers	Purpose	
1	455 KC	ONE TURN LOOSELY COUPLED TO WAVEMAGNET	Chassis	600 KC	Adj. T1, T2, T3 for maximum output.	For L.F. Alignment	
2	1620 KC		—	Gang wide open.	CIC	Set Oscillator to dial scale.	
3	535 KC		—	Gang Closed	Adjust slug in T6	Set Oscillator to dial scale.	
4	REPEAT STEPS 2 & 3		—	—	—	—	—
5	1260 KC		—	—	1260 KC	CIA	Align loop ant.

ZENITH RADIO Chassis 7AT42 & 7AT42Z1, Model "Royal 300"  
(Continued from page 182)

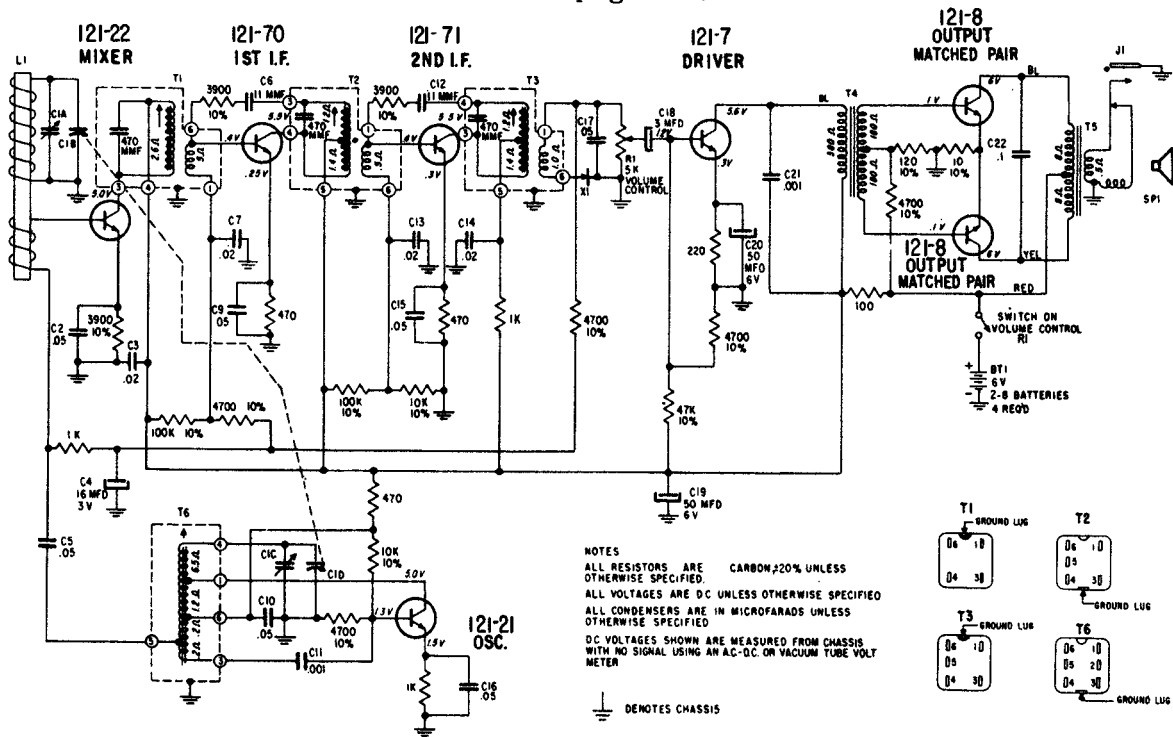

**SCHEMATIC DIAGRAM FOR 7AT42**

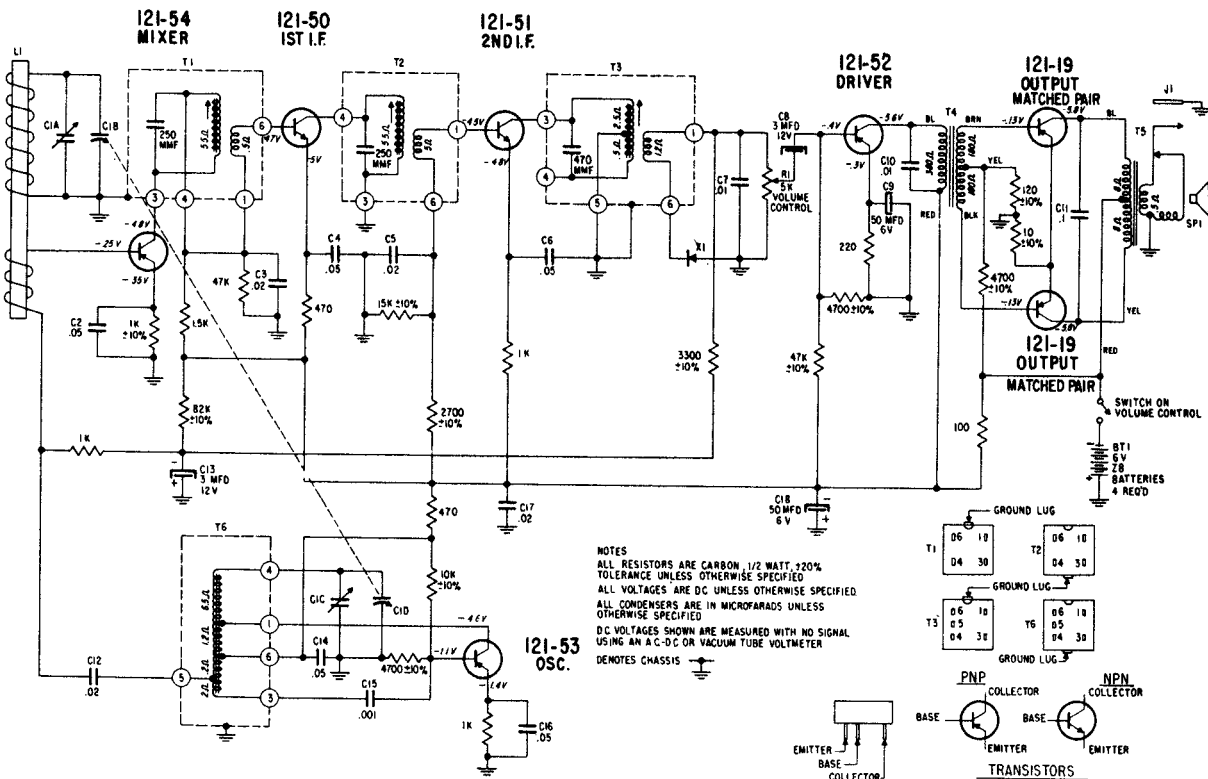

**SCHEMATIC DIAGRAM FOR 7AT42Z1**

# ZENITH RADIO CORPORATION

## MODEL "ROYAL 500D"

### CHASSIS 8AT40Z2

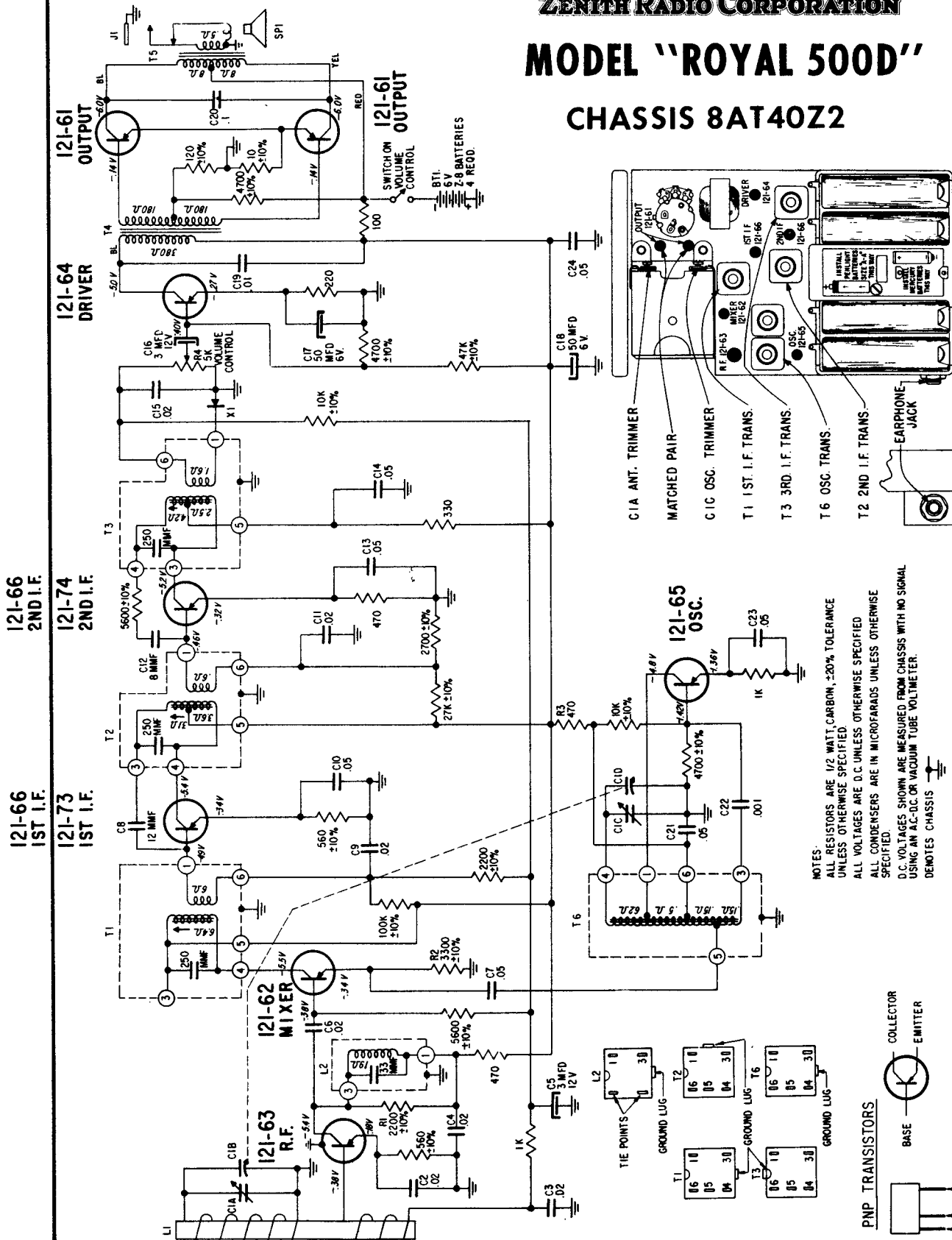

TRANSISTOR & TRIMMER LAYOUT FOR CHASSIS 8AT40Z2 USING 121-66 TRANSISTORS

121-66  
1ST I.F.

121-74  
2ND I.F.

121-64  
DRIVER

121-61  
OUTPUT

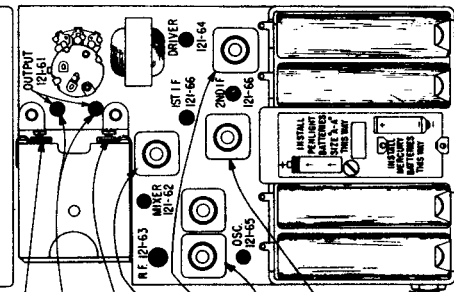

NOTES:  
 ALL RESISTORS ARE 1/2 WATT, CARBON, ±20% TOLERANCE UNLESS OTHERWISE SPECIFIED.  
 ALL VOLTAGES ARE D.C. UNLESS OTHERWISE SPECIFIED.  
 ALL CONDENSERS ARE IN MICROFARADS UNLESS OTHERWISE SPECIFIED.  
 D.C. VOLTAGES SHOWN ARE MEASURED FROM CHASSIS WITH NO SIGNAL USING AN A.C.-D.C. OR VACUUM TUBE VOLTMETER.  
 ⚡ DENOTES CHASSIS GROUND

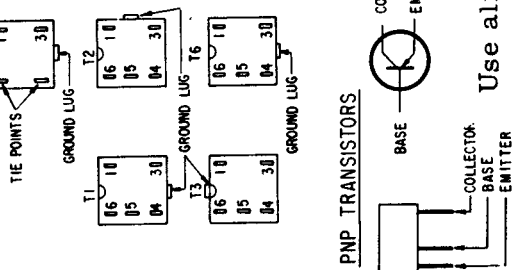

Use alignment table on page 182 for this model also.



# ZENITH RADIO MODEL "ROYAL 700L" CHASSIS 7AT43 & 7AT43Z3

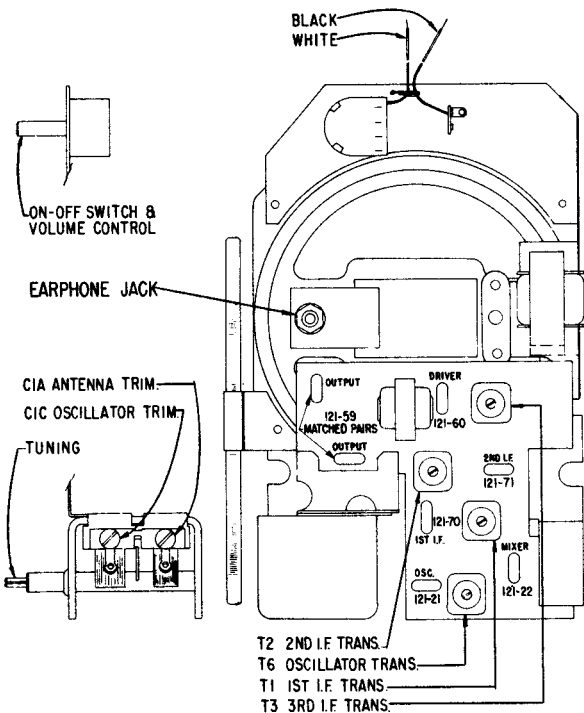

### RESISTANCE MEASUREMENTS

When making resistance measurements in the circuit, it is most important to remove the transistors in the circuit under test otherwise readings obtained will be incorrect. This is the direct result of a transistor acting as a diode.

In addition to this, it is important to know the internal battery voltage of the ohm meter as well as battery polarity of the meter leads since incorrectly placing ohm meter leads across an electrolytic condenser with low working voltage may damage the capacitor due to excessive reverse current or excessive voltage.

### VOLTAGE READINGS

It is suggested that a VTVM with an excellent low range scale be used to measure all circuit voltages. All voltages indicated on the accompanying diagram have been measured under no signal conditions and a battery supply voltage of nine volts. Under these no signal conditions, a check can be made of the batteries. The total voltage should be nine volts.

Use alignment table on page 182 for this model also.

### TRANSISTOR & TRIMMER LAYOUT FOR 7AT43

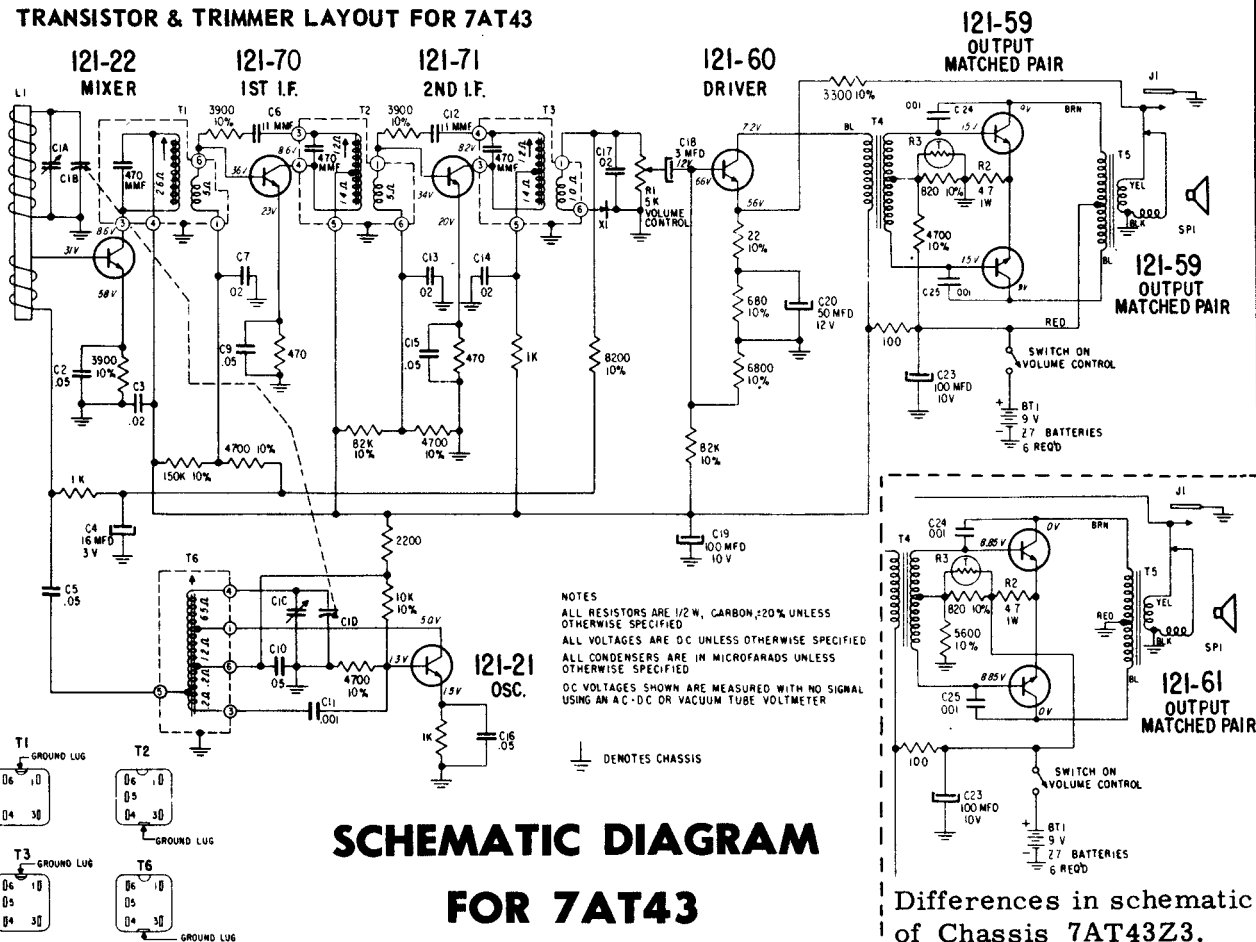

Differences in schematic of Chassis 7AT43Z3.

6V6GT  
PWR. AMP.

1/2 12AX7

1/2 12AX7

6J5

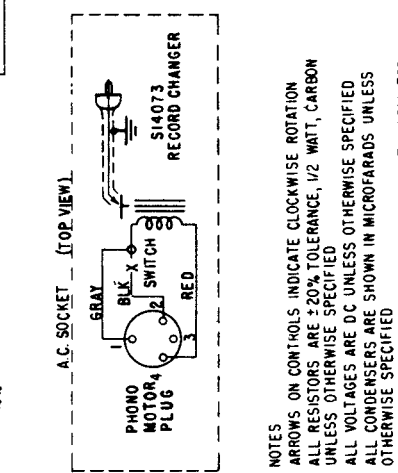
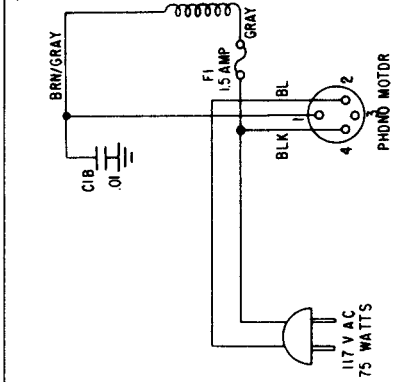
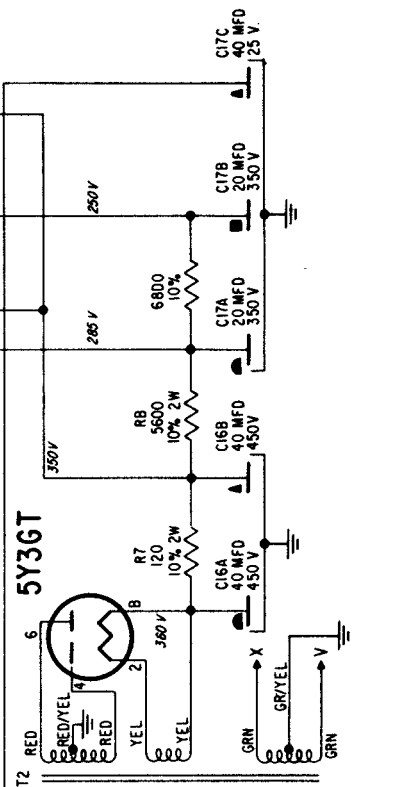
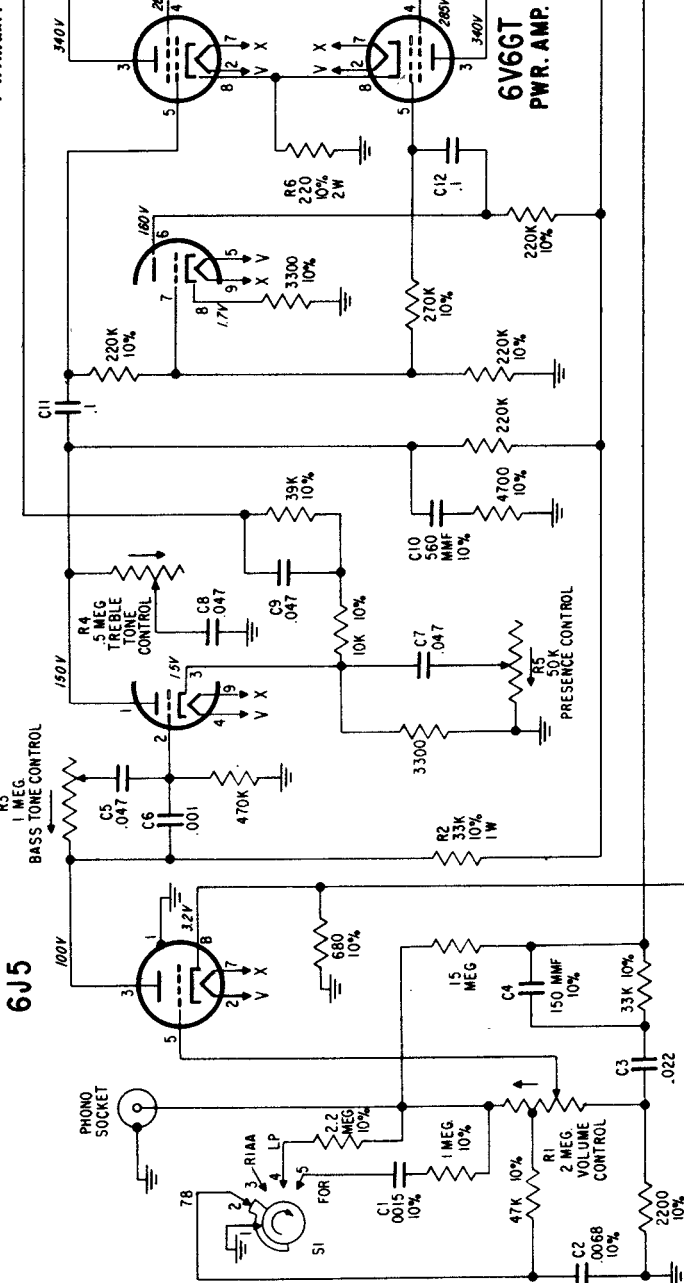

NOTES  
 ARROWS ON CONTROLS INDICATE CLOCKWISE ROTATION  
 ALL RESISTORS ARE ±20% TOLERANCE, 1/2 WATT, CARBON  
 UNLESS OTHERWISE SPECIFIED  
 ALL VOLTAGES ARE DC UNLESS OTHERWISE SPECIFIED  
 ALL CONDENSERS ARE SHOWN IN MICROFARADS UNLESS  
 OTHERWISE SPECIFIED  
 ALL VOLTAGES ARE MEASURED FROM POINTS INDICATED  
 TO CHASSIS WITH AN A.C.-D.C. VACUUM TUBE VOLTMETER

ZENITH RADIO Chassis 5Z21, Models HF17E, -H, -R, HF21E, -R

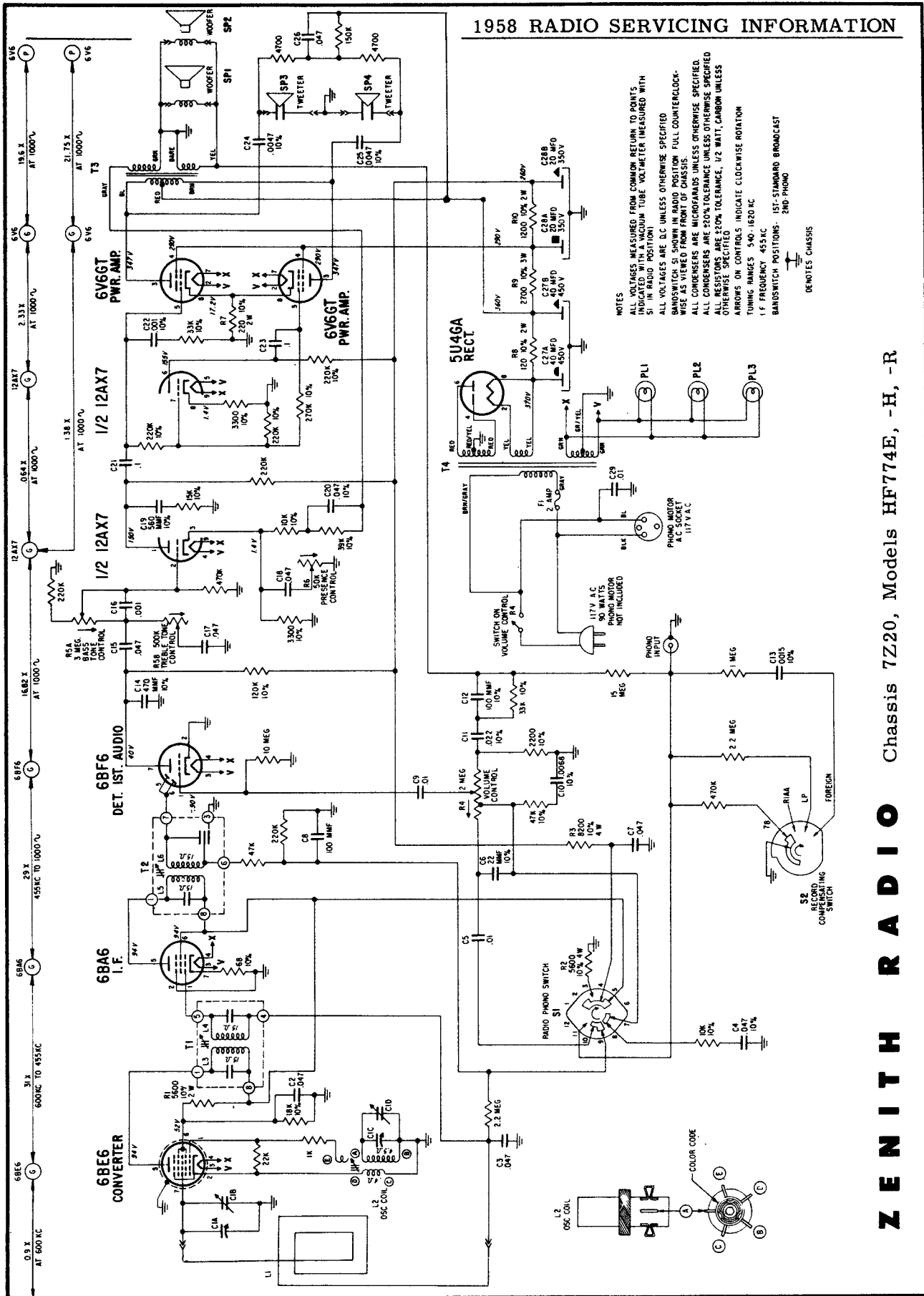

NOTES  
 ALL VOLTAGES MEASURED FROM COMMON RETURN TO POINTS INDICATED WITH A VACUUM TUBE VOLTMETER MEASURED WITH S1 IN RADIO POSITION  
 ALL VOLTAGES ARE D.C. UNLESS OTHERWISE SPECIFIED  
 BANDSWITCH S1 SHOWN IN RADIO POSITION FULL COUNTERCLOCKWISE AS VIEWED FROM FRONT OF CHASSIS.  
 ALL CONDENSERS ARE MICROFARADS UNLESS OTHERWISE SPECIFIED  
 ALL RESISTORS ARE  $\pm 20\%$  TOLERANCE UNLESS OTHERWISE SPECIFIED OTHERWISE SPECIFIED  
 ARROWS ON CONTROLS INDICATE CLOCKWISE ROTATION  
 TUNING RANGES 540-1620 KC  
 IF FREQUENCY 455 KC  
 BANDSWITCH POSITIONS: 1ST-STANDARD BROADCAST 2ND-PHONO  
 DEMOTES CHASSIS

ZENITH RADIO Chassis 7Z20, Models HF774E, -H, -R

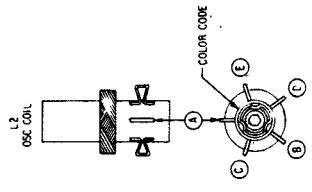



# ZENITH Alignment Chassis 11A20 and 11A21

(See page 188 for circuit of 11A20, and page 190 for circuit of 11A21)

A vacuum tube voltmeter with an isolation resistor of 2,000,000 ohms in series with the hot lead will serve for FM adjustments. This lead should be shielded.

An AC output meter connected across the primary or secondary of the output transformer will be satisfactory for all AM adjustments.

The signal generator output should be kept just high enough to get an indication on the meter.

OPERATION	CONNECT OSCILLATOR TO	DUMMY ANTENNA	INPUT SIGNAL FREQUENCY	BAND	SET DIAL TO	ADJ. TRIMMERS	PURPSE
1	Pin 2 12AT7 Converter	.05 mfd.	455 Kc. Modulated	AM	600 Kc.	L10, 11, 13, 16 & 17	Align I.F. channel for maximum output.
2	Antenna Post AM	.05 mfd.	1600 Kc. Modulated	AM	1600 Kc.	C8D	Set oscillator to dial scale.
3	Antenna Post AM	.05 mfd.	1400 Kc. Modulated	AM	1400 Kc.	C8B	Align antenna stage.
4	<b>IMPORTANT:</b> Before attempting to align the FM portion of this receiver the Band switch should be turned to "FM".						
5 (a)	Pin 1 (grid) on 6AU6 limiter	.05 mfd.	10.7 Mc. Unmodulated	FM		L18	Align primary of discriminator for maximum reading.
6 (b)	Pin 1 (grid) on 6AU6 limiter	.05 mfd.	10.7 Mc. Unmodulated	FM		L19	Adjust secondary of discriminator for zero reading.
7 (c)	Pin 1 (grid) on 6BA6 2nd IF	.05 mfd.	10.7 Mc. Unmodulated	FM		L14, 15	Align 3rd IF transformer for maximum reading.
8 (c)	Pin 1 (grid) on 6BA6 1st IF	.05 mfd.	10.7 Mc. Unmodulated	FM		L12	Align primary 2nd IF transformer for maximum reading.
9 (c)	Pin 2 on 12AT7 converter	.05 mfd.	10.7 Mc. Unmodulated	FM		L8, 9	Align 1st IF transformer for maximum reading.
10 (c)	<b>REPEAT STEPS 7, 8 &amp; 9</b>						
11 (c)	Antenna Post FM (Remove line antenna)	270 ohms	98 Mc. Unmodulated	FM	98 Mc.	L6 Osc. Coil Slug.	Set Oscillator to dial scale.
12 (c) (d)	Antenna Post FM (Remove line antenna)	270 ohms	98 Mc. Unmodulated	FM	98 Mc.	L4 Det. Coil Slug.	Align det. stage to maximum reading.

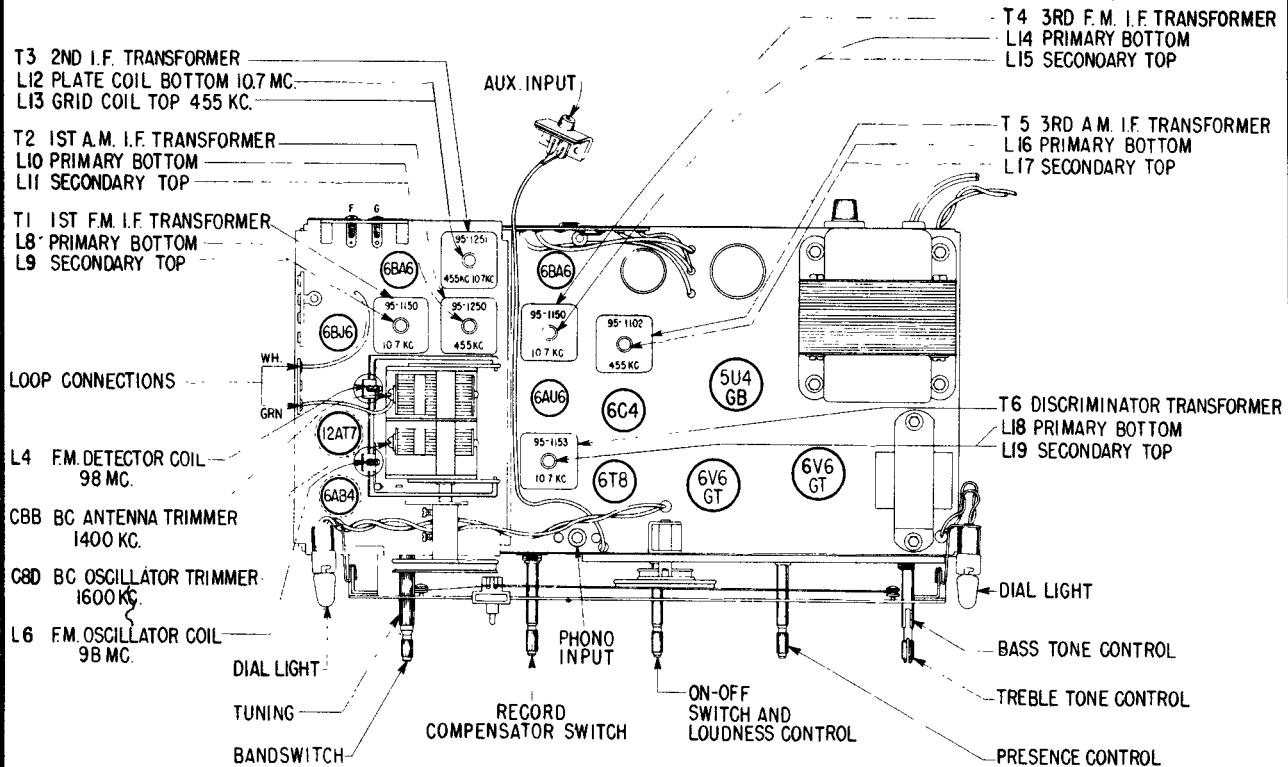

## Tube & Trimmer Location Chassis 11A20

(Chassis 11A21 is practically identical in layout except that 12AU7 replaces 6C4)

**HF1284D  
HF1284ED  
MODELS HF1284LD CHASSIS 11A21  
HF1284YD  
HF1286RD**

**ZENITH RADIO CORPORATION**

(Alignment data is on page 189)

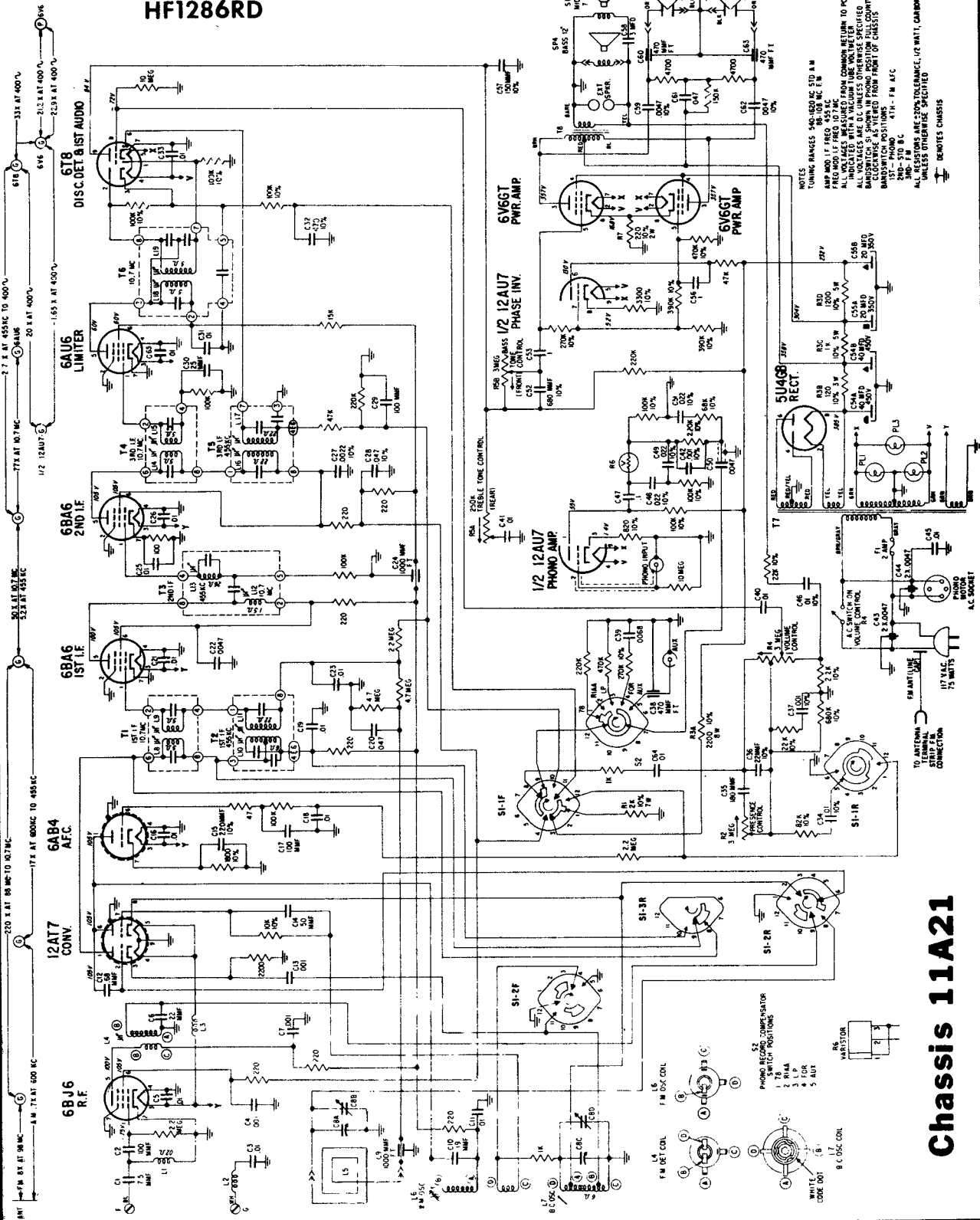

**Chassis 11A21**

NOTES  
TUNING RANGES: 400 KC TO 455 KC, 455 KC TO 400 KC, 400 KC TO 455 KC  
AMP MOD. I.F. FREQ. 455 KC  
ALL VOLTAGES MEASURED FROM COMMON RETURN TO POINTS INDICATED WITH A VACUUM TUBE VOLTMETER  
BANDWIDTHS SHOWN IN PHONO SECTION FOLLOW COUNTER-CLOCKWISE AS VIEWED FROM FRONT OF CHASSIS  
157 - PHONO POSITION - 114 - P.M. A.C.  
2ND - 210 B.C.  
ALL RESISTORS ARE 20% TOLERANCE, 1/2 WATT, CARBON UNLESS OTHERWISE SPECIFIED  
☞ REMOTES CHASSIS

VOLUME R-18, MOST-OFTEN-NEEDED 1958 RADIO SERVICING INFORMATION

# Index

<u>Admiral Corp.</u>	<u>Admiral, Cont.</u>	<u>Arvin</u>	<u>Du Mont Labs.</u>	<u>G.E. Cont.</u>
1B1 18	227 14	1581 22	RA-902 54	P760A 74
1B11 18	228 14	5578 23	1210 54	P761A 74
1C1 18	231 17	8571 24	<u>Emerson Radio</u>	P765A,-B 75
1C12 18	237 17	8572 24	851B 57	P766A,-B 75
1C14 18	242 6	8573 24	867B 58	<u>Montgomery-</u>
1D1 18	244 6	8576 25	870B 57	<u>Ward</u>
1D11 18	245 6	9574 26	871B 56	BR-1102A 76
1D12 18	248 6	1.41100 24	874B 57	BR-1557B 77
1E13 18	263 3	1.41300 24	875B 62	BR-1558B 77
1E14 18	264 3	1.41400 25	876B 63	HA-1645A 78
3J1 20	265 3	1.43000 26	881B 63	HA-1646A 78
3J1A 19	268 3	1.43500 23	882B 63	<u>Motorola, Inc.</u>
3J14 20	275 6	1.44000 22	883B 63	2F21B,-R 106
3J16 20	278 6	<u>Buick</u>	884B 63	3F22 106
3K1 21	279 6	981813 32	885B 60	3H24B-1 107
4P2 8	284 9	981814 34	886B 60	3H24B-2 107
4P21 8	288 9	981902 34	888 59	3H24S-1 107
4P22 8	289 9	981903 36	120349B 58	3H24S-2 107
4P24 8	292 10	<u>Bulova Watch</u>	120355B 56	3H25B,-1 107
4P28 8	296 10	100 27	120363A 57	3H25M,-1 107
4S2 16	298 10	110 27	120365B 62	5C22+ 108
4T2 21	299 10	200 27	120366B 58	5C23+ 108
4W2 4	303 12	220 27	120371B 60	5K21+ 109
5B4 6	304 12	230 27	120372B 63	5K23+ 109
5C4 3	331 19	240 27	120373B 63	5P31A 110
5D4 6	335 19	260 27	120374 59	5P32+ 110
5E4 9	338 19	270 27	120398B 63	5P33+ 110
5RP4,-A 11	341 21	310 27	<u>Ford (Auto)</u>	5R23+ 111
5RP41 11	347 21	320 27	B7A-18805-A1	5T21W-1 112
5RP42 11	362 21	<u>Chevrolet</u>	B7A-18805-B1	5T22+ 112
6B3 12	363 21	987724 28	B8A-18805-A	5T23+ 112
6R2B 13	364 21	987727 30	B8A-18805-B	5T24+ 113
6S2 14	366 21	987730 42	all on 90, 91	5T25+ 113
7M1 15	372 21	3748611 42	FEV-18805F 96	6H26S-1 114
7M11 15	373 21	<u>Delco</u>	<u>Gamble-Skogmo</u>	6H26S-1A 114
7M12 15	382 13	AC-2905 28	RA48-8158A 64	6H27+ 114
7M14 15	383 13	AC-2906 30	<u>General-Elect.</u>	6K22+ 114
7M15 15	384 13	981813 32	T105 65	6P34E,-S 115
7M16 15	402 16	981814 34	T106 65	6X31+ 116
7M18 15	403 16	981814 34	T115 66	6X32E 116
8H1 16	404 16	981902 34	T116 66	6X39A,-1 117
8K1 17	HT2236 21	981903 36	C399 67	6X39A-2 117
200 4	HT2237 21	987724 28	C415,-A,-B 68	BKA 6X 101
202 4	<u>American</u>	987727 30	C416,-A,-B 68	CTA 6X 101
215 4	<u>Motors</u>	987730 42	C417 68	7MX 79
217 4	8990494 94	988671 38	C420 69	BKA 7X 101
218 4	8990543 92	988672 40	C421 69	CTA 7X 101
221 14		988822 44	P710A,-B 70	CTM7X 80
		988823 42	P710C,-C, 70	OEA 7X 82
		988837 46	P711A,-B 70	PCA 7X 101
		989001 48	P711C,-C, 70	VWA 7 83
		989002 50	P725 72	8M 84
		989127 52	P726 72	8MX 85
		989129 42	P745A 73	CTA 8X 86
		989131 46	P746A 73	CTM8X 88
		3748611 42	P750A 74	15KT24+ 114
				CTM57X 88

VOLUME R-18, MOST-OFTEN-NEEDED 1958 RADIO SERVICING INFORMATION

<u>Motorola, Cont.</u>	<u>Philco, Cont.</u>	<u>RCA, Continued</u>	<u>Spartan</u>	<u>Westinghouse+</u>
74MF 90	F-752 122	SHF-6 151	CR-729 158	H-632T5 169
76MF(SR) 91	F-754 122	SHF-7 151		H-633T5 169
83MR 92	F-758 122	8BT9 146	<u>Studebaker</u>	H-636T6 171
84MA 94	F-760 123	8BX5 149	AC-2905 28	H-637T6 171
84MF 90	T-800 120	8BX6 150	AC-2906 30	H-644T6 171
84MS 96	F-809 124	8BX7 150		H-645T6 171
86MF 91	F-813 124	8C5 145	<u>Sylvania Elec.</u>	H-648T4 166
397 97	F-815 124	8C6 145	1-609-6 161	H-651P6 167
397X 100	F-817 124	8C51 145	1-617-1 159	H-652P6 167
398X 98	847 132	8-EY-31 153	1-620-1 160	H-653P6 167
HS-559 110	848 132	8HF45P 151	1-621-1 161	V-2239-4 165
HS-561 110	also 134, 137	8X5 145	1-621-2 161	V-2239-5 166
HS-562 115	925 138	8X6 145	1-623-1 162	V-2278-4 167
HS-563 116	F-963 123	8X51 145	1-624-1 162	V-2296-1 168
HS-564 116	F-974 125	SHF-8 154	3203 159	V-2390-1 169
HS-578 108	F-1372, -X 126	9BT9 146	3204 159	V-2390-3 170
HS-579 108	F-1374 126	9C7 155	3305 160	V-2391-1 171
HS-590 114	F-1402 126	9C8 155	4307 161	V-2391-2 171
597X 101	F-1404 126	9-ED-2KF 152	4308 161	V-2500-1 172
HS-598 106	F-1406 127	9-ED-2LE 152	4309 161	V-2501-1 173
HS-599 106	F-1408 127	9-ED-32 154	4406 162	
600X 102	F-1500 130	9-ES-5H 152	4501 162	<u>Zenith Radio</u>
HS-600 111	F-1600 128	9-ES-5JE 152		4A41 174
HS-601 107	F-1700 128	9-ES-6H 153	<u>Trav-ler</u>	5A08 176
HS-602 107	F-1702 128	9-ES-6J 153	46-37 163	5A41 175
HS-606 114	F-1800 131	9US5H 156	56C220 164	5Z21 186
HS-608 109	F-1801 131	9US5KE 156	56C230 164	6A03 177
HS-619 114	F-1802 128	9X10 155	56C231 164	AP6B 180
HS-621 114	F-1803 128	9XL1 157	56C232 164	AP6J,V 180
HS-625 112	F-1804 131	SHF-9 154	56C233 164	7A05 178
HS-627 112	F-1805 128	RS-152A,B 152	56C240 164	7AT42 182
HS-628 113	P-5701 132	RS-152D,E 152	T200 163	7AT42Z1 182
HS-629 113	P-5702 134	RS-153A 153	T201 163	7AT43 185
HS-630 117	P-5703 135	RS-157B 153	T202 163	7AT43Z3 185
HS-632 109	C-5705 132	RS-158D,F 154	T203 163	7Z20 187
HS-643 111	C-5707 135	RS-158J 144	T204 163	AP7F 181
HS-683 117	C-5709 135	RS-159B 151	T210 163	8AT40Z2 184
HS-684 117	M-5741 136	RS-164, -A 151	T211 163	AP8J 181
852 103	P-5801 137	RS-164B 141	T212 163	AP9B 180
853 103	P-5803 138	RS-170 154	T213 163	11A20 188
854 103	C-5809 139	RS-170B,D 152	236 163	11A21 190
923 104	M-5841 140	RC-1149 149	5220 164	HF17E 186
		RC-1156B 142		HF17H, -R 186
<u>Oldsmobile</u>	<u>Pontiac</u>	RC-1161 150	<u>United Motors</u>	HF21E, -R 186
989001 48	988671 38	RC-1161A 150	see Delco	300 182
989002 50	988672 40	RC-1164, A 146		A402 174
989127 52	988822 44	RC-1164B 146	<u>Westinghouse</u>	500D 184
989129 42	988823 42	RC-1166A 155	HF100BN 172	A504 175
989131 46	988837 46	RC-1166B 155	HF101BN 172	A555 176
		RC-1167A 157	HF104DP 173	A624G 177
<u>Packard-Bell</u>	<u>RCA Victor</u>	RC-1170 145	HF105DP 173	A624W, -Y 177
6R1 118	HFP 141	RC-1170A 156	HF106DP 173	700L 185
6RC1 118	1BT58 142	RC-1178 145	H-435T5A 170	A730E, -R 178
	1BX5 143	RC-1179 145	H-437T5A 170	HF774E 187
<u>Philco Corp.</u>	1BX6 143	RC-1179A 145	H-438T5A 170	HF774H, R 187
RT-100 129	1BX7 143	RC-1183, A 143	H-570T4 165	HF1178RD 188
T-500 119	HRD-2 144	RC-1183B 143	H-571T4 165	HF1185MD 188
T-700 120	6-EY-3A 152		H-572T4 165	HF1185RD 188
F-743 122	6-EY-3B 152	<u>Sentinel</u>	H-621P6 168	HF1284+ 190
F-750 122	6-EY-3C 152	CR-729 158	H-622P6 168	HF1286RD 190