

THE No 1 UK MAGAZINE FOR ELECTRONICS TECHNOLOGY & COMPUTER PROJECTS

# **EPE** EVERYDAY PRACTICAL ELECTRONICS

www.epemag.com

## **1000:1 UHF PRESCALER**

- ★ For frequency counters
- ★ Extends the range to over 2.8GHz

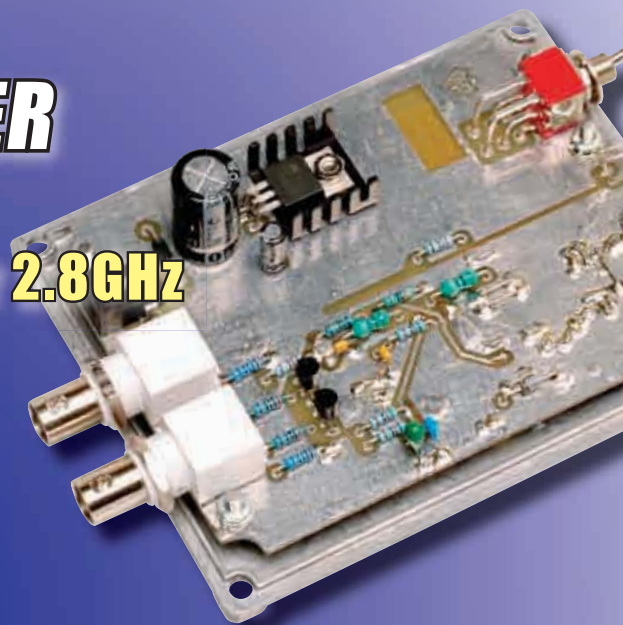

## **RADAR SPEED GUN**

PART 2: Construction details

## **RECYCLE IT**

An automatic stopwatch timer  
from salvaged parts

## **BREADBOARDING PROJECTS**

- ★ Clap Switch
- ★ Low-Budget Intercom

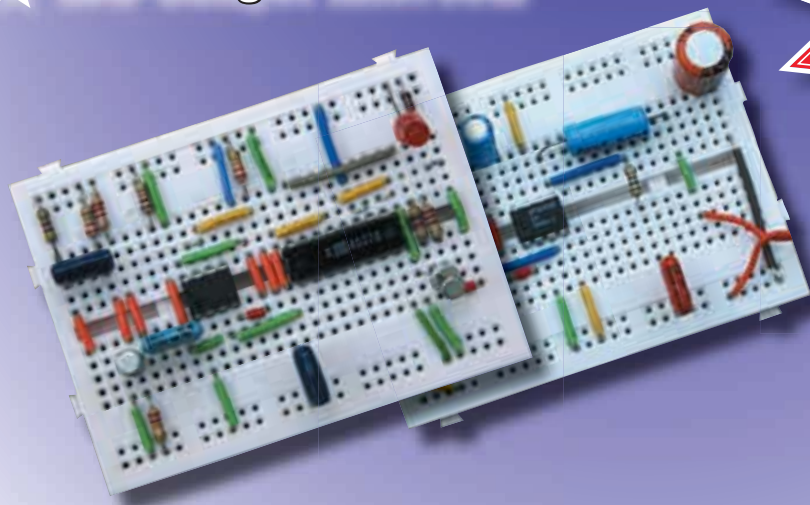

\$8.75 US \$10.25 CAN  
JAN 2009 PRINTED IN THE UK



7 25274 07806 6 01

**Copyright © 2008, Wimborne Publishing Ltd**  
(Sequoia House, 398a Ringwood Road, Ferndown, Dorset BH22 9AU, UK)

**and TechBites Interactive Inc.,**  
(PO Box 857, Madison, Alabama 35758, USA)

**All rights reserved.**

## **WARNING!**

The materials and works contained within *EPE Online* — which are made available by Wimborne Publishing Ltd and TechBites Interactive Inc — are copyrighted. You are permitted to make a backup copy of the downloaded file and one (1) hard copy of such materials and works for your personal use. International copyright laws, however, prohibit any further copying or reproduction of such materials and works, or any republication of any kind.

TechBites Interactive Inc and Wimborne Publishing Ltd have used their best efforts in preparing these materials and works. However, TechBites Interactive Inc and Wimborne Publishing Ltd make no warranties of any kind, expressed or implied, with regard to the documentation or data contained herein, and specifically disclaim, without limitation, any implied warranties of merchantability and fitness for a particular purpose.

Because of possible variances in the quality and condition of materials and workmanship used by readers, *EPE Online*, its publishers and agents disclaim any responsibility for the safe and proper functioning of reader-constructed projects based on or from information published in these materials and works. In no event shall TechBites Interactive Inc or Wimborne Publishing Ltd be responsible or liable for any loss of profit or any other commercial damages, including but not limited to special, incidental, consequential, or any other damages in connection with or arising out of furnishing, performance, or use of these materials and works.

# PCB-POOL<sup>®</sup>.COM

## Low Cost PCB Manufacturing Service

- Prototypes manufactured from student's own designs
- Professional quality for a discount price
- The PCB-POOL<sup>®</sup> concept has made professional quality PCB prototypes available to students & hobbyists worldwide

*Simply send us your files & receive your prototypes in a few days!!!*

## Download our FREE PCB Layout Software!

- Schematic Capture
- PCB Layout
- Auto Router & Auto Placer
- Complete Component Library
- Professional Version

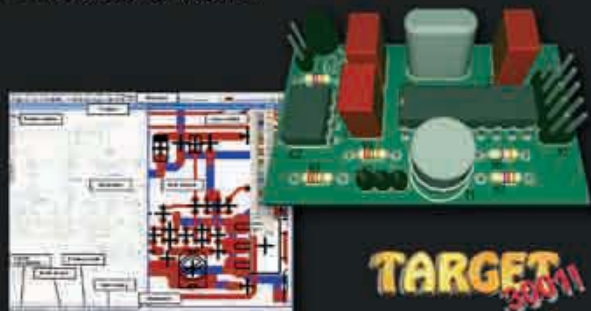

[www.free-pcb-software.com](http://www.free-pcb-software.com)

## WATCH UR PCB<sup>®</sup>

### View your PCB as it gets manufactured!

We send HD images at each production stage so you can track its progress!!

- ◆ Drilling
- ◆ Exposure
- ◆ Tin Stripping
- ◆ UV curing
- ◆ Hot air levelling (HAL)



[www.pcb-pool.com](http://www.pcb-pool.com)

**Email: [sales@pcb-pool.com](mailto:sales@pcb-pool.com) Free Phone UK: 0800 389 8560**

Simply send your files & order ONLINE **WWW.PCB-POOL.COM**

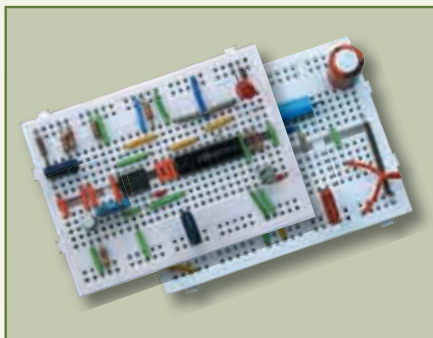
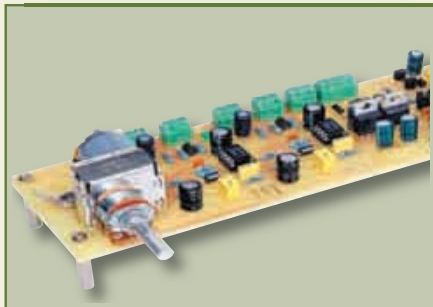

© Wimborne Publishing Ltd 2008. Copyright in all drawings, photographs and articles published in *EVERYDAY PRACTICAL ELECTRONICS* is fully protected, and reproduction or imitations in whole or in part are expressly forbidden.

Our February 2009 issue will be published on Thursday 8 January 2009, see page 80 for details.

Everyday Practical Electronics, January 2009

## Projects and Circuits

- 1000:1 UHF PRESCALER** by Jim Rowe **10**  
 Extend the range of your frequency counter to over 2.8GHz
- 20W CLASS-A AMPLIFIER MODULE – Pt. 4** by John Clarke and Greg Swain **28**  
 Low-noise preamplifier and remote volume control
- RADAR SPEED GUN – Pt. 2** by Jim Rowe **40**  
 Construction details
- BREADBOARDING PROJECTS** by Dr Malcolm Plant **54**  
 Part 4 – Clap Switch and Low-Budget Intercom
- INGENUITY UNLIMITED** Sharing your ideas with others **58**  
 Tuner Control – Digital tuning

## Series and Features

- TECHNO TALK** by Mark Nelson **20**
- FLOWCODE AND THE MICROCHIP PICKIT 2** **22**  
 Using Flowcode to programme PICs with PICkit 2
- RECYCLE IT** by Julian Edgar **50**  
 An automatic stopwatch timer from salvaged parts
- PRACTICALLY SPEAKING** by Robert Penfold **52**  
 Substituting components
- CIRCUIT SURGERY** by Ian Bell **62**  
 Slew Rate Limiting
- PIC N' MIX** by Mike Hibbett **65**  
 Interfacing PICs to the Internet via Ethernet – Part 4
- NET WORK** by Alan Winstanley **74**  
 The new *EPE* website

## Regulars and Services

- EDITORIAL** **7**
- NEWS** – Barry Fox highlights technology's leading edge **8**  
 Plus everyday news from the world of electronics
- EPE/MICROCHIP EXCLUSIVE SPECIAL OFFER** **26**  
 A Microchip PICkit 2 Debug Express Kit for only £9.99
- PIC RESOURCES CD-ROM** **27**  
 EPE PIC Tutorial V2, plus PIC Toolkit Mk3 and a selection of PIC-related articles
- BACK ISSUES** Did you miss these? **60**
- CD-ROMS FOR ELECTRONICS** **68**  
 A wide range of CD-ROMs for hobbyists, students and engineers
- SUBSCRIBE TO EPE** and save money **71**
- READOUT** Matt Pulzer addresses general points arising **72**
- DIRECT BOOK SERVICE** **75**  
 A wide range of technical books available by mail order, plus more CD-ROMs
- EPE PCB SERVICE** **78**
- ADVERTISERS INDEX** **80**

**08717 Credit Card Sales 177 168**

Ho! Ho! Ho! Christmas 2008 is on it's way  
**BUT DON'T PANIC!!**  
We have some fantastic gift ideas for young (and older) enquiring minds

**Electronic Project Labs**

An electronics course in a box! All assume no previous knowledge and require NO solder. See website for full details



30 in ONE - £16.95  
Order Code EPL030KT



130 in ONE - £39.95  
Order Code EPL130KT



300 in ONE - £59.95  
Order Code EPL300KT



500 in ONE - £149.95  
Order Code EPL500KT



Robot Sensor - £19.95  
Order Code EPLR20KT



Digital Recording Laboratory - £29.95  
Order Code EPLDRKT



AM-FM Radio Kit - £6.95  
Order Code ERKAFKT



Short Wave Kit - £6.95  
Order Code ERKSWKT



Crystal Radio Kit - £6.95  
Order Code ERKCKT



Electronic Bell - £8.95  
Order Code EAKEBKT



Electronic Motor - £8.95  
Order Code EAKEMKT



Generator - £8.95  
Order Code EAKEGKT



Room Alarm - £4.95  
Order Code EAKRAKT



Hand Held Metal Detector - £7.95  
Order Code ELMDX7



Metal Detector - £7.95  
Order Code ELMDKT

**Mechanical Motorised Wooden Kits**

Future engineers can learn about the operation of transmissions steered through gears or pulleys. Easy to build, no glue or soldering required.



Automech - £12.95  
Order Code C21-605KT



Coptermech - £12.95  
Order Code C21-604KT



Trainmech - £12.95  
Order Code C21-606KT



Hexapod Monster Robomech - £17.95  
Order Code C21-883KT  
(soldering required)



Stegomech - £12.95  
Order Code C21-602KT



Tyrannomech - £12.95  
Order Code C21-601KT

**Festive Fun Electronic Project Kits**

250 different educational electronic kits. Soldering is required.

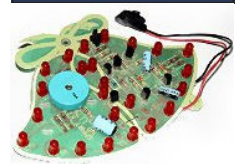

Musical LED Jingle Bells - £17.95  
Order Code 1176KT



Flashing LED Christmas Tree - £5.95  
Order Code VMK100KT

**See our website for even more great gift ideas!**



[www.QuasarElectronics.com](http://www.QuasarElectronics.com)

Secure Online Ordering Facilities • Full Product Listing, Descriptions & Photos • Kit Documentation & Software Downloads

## Robot Kits

These educational electronic robot kits make a great introduction to the exciting world of robotics and require NO soldering. See website for details



**Moon Walker - £33.95**  
Order Code 4015KT



**Hyper Peppy - £28.95**  
Order Code 4016KT



**Robotic Arm - £59.95**  
Order Code 4017KT



**Sumo Man - £59.95**  
Order Code 4019KT



**Air Shooter - £33.95**  
Order Code 4025KT

**Go online for  
Special Offers**

## Tools & Equipment



**Soldering Set - £9.95**  
Order Code SOL939



**Hobby Tool Set - £13.95**  
Order Code HTK300



**20 Piece Electronics Tool Set - Now £22.95**  
Order Code HTK368



**5" Illuminated Magnifier - £39.95**  
Order Code HTM015



**48W Digital Soldering Station - £59.95**  
Order Code SOL050



**3-12V 1.5A PSU - £24.95**  
Order Code PSU400



**0-30V/0-3A Regulated Power Supply - £89.95**  
Order Code PSU676



**Hobby DMM - £5.95**  
Order Code DMM006



**Clamp Meter - £14.95**  
Order Code DMC616



**Helping Hands - £4.95**  
Order Code 710.165



**Ultrasonic Distance Measurer - £19.95**  
Order Code 600.634



**Universal Battery Tester - £4.95**  
Order Code 690.393



**Credit Card Sales**  
**0871 717 7168**

## Home and Leisure



**4-ch Sequencer - £39.95**  
Order Code ELT298

**12V 150W Power Inverter - £29.95**  
Order Code RPI530



**Metal Detector - £34.95**  
Order Code 499.920



**120mm Rechargeable Spotlight - £18.95**  
Order Code TOR260



**Windup Torch - £8.95**  
Order Code TOR149



**Intelligent NiCd/NiMH Charger - £14.95**  
Order Code 690.163



**Snow Machine - £79.95**  
Order Code ELT568



**Party Bubbles - £14.95**  
Order Code ELT562



**25W Guitar Amplifier with Overdrive - £59.95**



**Order Code MUS033 Multi-Band Radio Receiver - £24.95**



**Order Code RAD4997 Audio/Video Transmission System - £39.95**



**Order Code RAD4997 Audio/Video Transmission System - £39.95**



[www.QuasarElectronics.com](http://www.QuasarElectronics.com)

Secure Online Ordering Facilities • Full Product Listing, Descriptions & Photos • Kit Documentation & Software Downloads

# EVERYDAY PRACTICAL ELECTRONICS FEATURED KITS

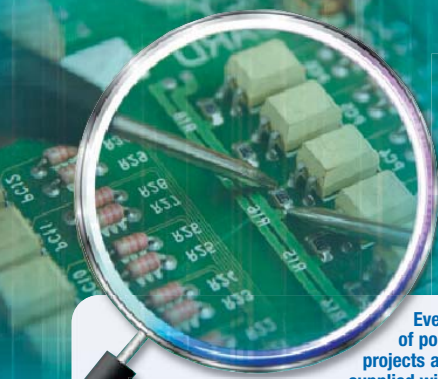

January '09

Everyday Practical Electronics Magazine has been publishing a series of popular kits by the acclaimed Silicon Chip Magazine Australia. These projects are 'bullet proof' and already tested down under. All Jaycar kits are supplied with specified board components, quality fibreglass tinned PCBs and have clear English instructions. Watch this space for future featured kits.

**Jaycar**  
Electronics

## KC-5441 £29.00 plus postage & packing

If you're into any kind of racing like cars, bikes boats or even the horses, this kit is for you. The electronics are mounted in the supplied jiffy box and the radar gun assembly can be made simply with two coffee tins fitted end to end. The circuit needs 12VDC at only 130mA so you can use a small SLA or rechargeable battery pack.

- Kit includes PCB and all specified electronic components.

As published in EPE Magazine Dec 2008



## RADAR SPEED GUN MKII KIT



## COURTESY INTERIOR LIGHT DELAY KIT

### KC-5392 £5.95 plus postage & packing

Many modern cars feature a time delay on the interior light. It still allows you time to buckle up and get organised before the light dims and finally goes out. This kit provides that feature for cars which don't already provide it. It has a soft fade out after a set time has elapsed, and features much simpler universal wiring than previous models we have had.

- Kit supplied with PCB with overlay, and all electronic components.
- Suitable for circuits switching ground or +12V or 24VDC (car & truck with negative chassis.)

As published in EPE Magazine Feb 2007



## 50MHz FREQUENCY METER KIT WITH LCD

### KC-5369 £16.00 plus postage & packing

Low cost and invaluable for servicing and diagnostics. This meter is autorangeing and displays the frequency in either Hz, kHz or MHz. Features compact size (130 x 67 x 44mm), 8 digit LCD display, high and low resolution modes, 0.1Hz resolution up to 150Hz, 1Hz resolution maximum up to 150Hz and 10Hz resolution above 16MHz. Kit includes PCB, case with machined and silkscreened lid, pre-programmed PIC and all electronic components with clear English instructions.

- Requires 9VDC wall adaptor (Maplin #GS74R)

As published in EPE Magazine Sept. 2006



## 3V TO 9V DC TO DC CONVERTER KIT

### KC-5391 £4.95 plus postage & packing

9V batteries are a great source of portable power, but let's face it - they don't last long if you want more than a few milliamps, and they are not real cheap either. This great little converter allows you to use regular Ni-Cd or Ni-MH 1.2V cells, or Alkaline 1.5V cells for 9V applications. Using low cost, high capacity rechargeable cells, the kit will pay for itself in no-time! You can use any 1.2-1.5V cells you desire. Imagine the extra capacity you would have using two 9000mAh D cells in replacement of a low capacity 9V cell.

- Kit supplied with PCB, and all electronic components.

As published in EPE Magazine June 2007



## V8 SOUNDING DOORBELL KIT

### KC-5405 £25.75 plus postage & packing

Be the envy of your mates as they hear the rumble of a big V8 when they press the button on your doorbell. You may have seen a few commercially available units, but they don't sound anything like this! Not only does it sound like the roar of a V8, but it also has background noise that sounds like tappets & valves working away, for an even more realistic effect. There is a V made from LEDs that like up in sync with the rumble & a large 100mm speaker ensures that it sounds true.

- Supplied with silk screened & solder masked PCBs, silk screened & machined case, push button bell switch, speaker, hook up wire, 100mm diameter pipe & all electronic components.

As published in EPE Magazine October 2007



## DELTA THROTTLE TIMER KIT

### KC-5373 £7.95 plus postage & packing

It will trigger a relay when the throttle is depressed or lifted quickly. There is a long list of uses for this kit, such as automatic transmission switching of economy to power modes, triggering electronic blow-off valves on quick throttle lifts and much more. It is completely adjustable, and uses the output of a standard throttle position sensor.

- Kit supplied with PCB and all electronic components.

As published in EPE Magazine Nov 2006

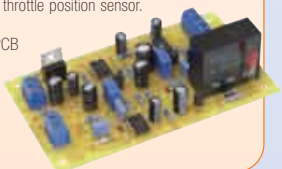

## SPEAKER BASS EXTENDER KIT

### KC-5411 £6.00 plus postage & packing

Most audiophiles know that loudspeaker enclosures have a natural frequency rolloff which is inherent in their design. Crude bass boost devices that are available simply boost the level of bass anywhere up to +18dB, to offer better bass response. This isn't the best way to do it. The Bass Extender kit boosts the level of the bass to counteract the natural rolloff of the enclosure, producing rich, natural bass. It gives an extra octave of response, and is sure to please even the most avid audiophiles.

- Kit supplied with PCB, and all electronic components.

As published in EPE Magazine March 2007



## PROGRAMMABLE CONTINUITY TESTER KIT

### KC-5362 £8.70 plus postage & packing

While most modern digital multimeters feature a continuity tester, it is only a very rough indication of the continuity. This unit will test for continuity from 1-100 ohms, giving a much more accurate reading. It is accurate, reliable and works well.

- Kit supplied with PCB, case with silk-screened panel and all electronic components.

As published in EPE Magazine April 2006



## INTERCOOLER WATER SPRAY CONTROLLER KIT

### KC-5422 £3.00 plus postage & packing

Intercooler water sprays are a very effective and inexpensive way of upgrading intercooler performance. Using a 'dump' system to trigger the spray often results in the need for frequent water top-ups. Simply add these few components to the Smart Fuel Mixture Display Kit (KC-5374) and reduce water consumption by up to two-thirds with no loss in cooling efficiency.

As published in EPE Magazine March 2008

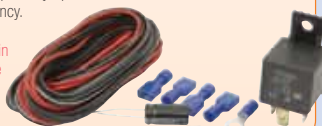

## LUXEON STAR LED DRIVER KIT

### KC-5389 £9.75 plus postage & packing

Luxeon high power LEDs are some of the brightest LEDs available in the world. They offer up to 120 lumens per unit, and will last up to 100,000 hours! This kit allows you to power the fantastic 1W, 3W, and 5W Luxeon Star LEDs from 12VDC. This means that you can take advantage of what these fantastic LEDs have to offer, and use them in your car, boat, or caravan.

- Kit supplied with PCB, and all electronic components.

As published in EPE Magazine April 2007



- Secure on-line ordering
- ALL prices in Pounds Sterling
- Minimum order ONLY 10 PDS

ORDER YOUR  
FREE  
CATALOGUE  
TODAY!



**Jaycar**  
Electronics

0800 032 7241

jaycarelectronics.co.uk

# SECURITY KITS FOR ELECTRONIC ENTHUSIASTS



## RFID SECURITY MODULE RECEIVER KIT

**KC-5393 £28.95 plus postage & packing**  
Radio Frequency Identity (RFID) is a contact-less method of controlling an event such as a door strike or alarm etc. An "RFID Tag" transmits a unique code when energised by the receiver's magnetic field. As long as a pre-programmed tag is recognised by the receiver, access is granted. This module provides normally open and normally closed relay contacts for flexibility. It works with all EM-4001 compliant RFID tags.



- Kit supplied with PCB, tag, and all electronic components.

As published in EPE Magazine Aug 2007

## INFRARED FLOODLIGHT KIT

**KG-9068 £7.95 plus postage & packing**  
Let your CCD camera see in the dark! This infrared light is powered from any 12-14VDC source and uses 32 x infrared LEDs to illuminate an area of up to 5-metres (will vary with light conditions). The PCB measures 56 x 75mm and draws a current of about 300mA.

- Kit is supplied with silkscreened/ gold plated/ solder-masked PCB, 32 x Infrared LEDs and all electronic components.
- Use our plugpack supply, MP3006.
- Not suitable for colour CMOS cameras.



## ROLLING CODE INFRARED KEYLESS ENTRY SYSTEM KIT

**KC-5458 £14.50 plus postage & packing**  
This excellent keyless entry system features two independent door strike outputs and will recognise up to 16 separate key fobs. The system keeps the coded key fobs synchronised to the receiver and compensates for random button presses while the fobs are out of range.



- Supplied with solder masked and silk screen printed PCB, two programmed micros, battery and all electronic components. The receiver requires a 12VDC 1.5A power supply. Some SMD soldering is required.

## INFRARED DETECTOR KIT

**KG-9086 £2.35 plus postage & packing**

This kit will switch on a LED when it detects infrared light from sources such as IR remote controls. Connect it to the Relay Card kit KG-9142 to make an infrared remote controlled relay. Project requires 9VDC.

- PCB dimensions: 55 x 15mm
- Kit supplied with Kwik Kit PCB, Infrared receiver and all electronic components.
- Can be battery powered.



## SCREECHER CAR ALARM KIT MKII

**KA-1813 £9.75 plus postage & packing**  
The Screecher MK II is very effective and produces an ear-piercing scream that will scare the pants off any would be thief. It is easy to construct and features entry delay with a soft warning tone, exit delay and high intensity deterrent LED.

- Kit includes PCB, siren, all electronic components and two adhesive warning stickers for no extra cost.

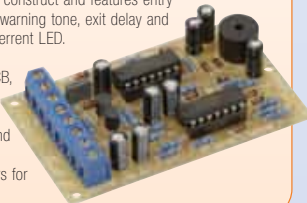

## ENGINE IMMOBILISER KIT MKII

**KC-5255 £9.75 plus postage & packing**

This Immobiliser repeatedly stalls the engine when a thief tries to start your car. The circuit allows the engine to start, but will stall the engine after about two seconds, giving the thief the impression that there is an intermittent problem.

- Kit supplied with PCB, plastic enclosure and all specified electronic components.

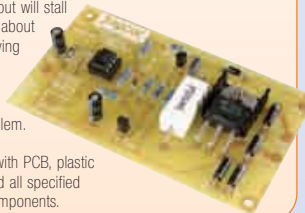

## POST & PACKING CHARGES

Order Value	Cost	
£10 - £49.99	£5	Max weight 12lb (5kg).
£50 - £99.99	£10	Heavier parcels POA.
£100 - £199.99	£20	Minimum order £10.
£200 - £499.99	£30	
£500+	£40	

Note: Products are despatched from Australia, so local customs duty & taxes may apply. Prices valid till 31/12/08



## HOW TO ORDER

- **ORDER ON-LINE:** [www.jaycarelectronics.co.uk](http://www.jaycarelectronics.co.uk)
- **PHONE:** 0800 032 7241\*
- **FAX:** +61 2 8832 3118\*
- **EMAIL:** [techstore@jaycarelectronics.co.uk](mailto:techstore@jaycarelectronics.co.uk)
- **POST:** P.O. Box 107, Rydalmere NSW 2116 Australia
- **ALL PRICING IN POUNDS STERLING**
- **MINIMUM ORDER ONLY £10**

\*Australian Eastern Standard Time (Monday - Friday 09.00 to 17.30 GMT + 10 hours only) Expect 10-14 days for air parcel delivery

## 3 METRE IR LIGHT BEAM KIT

**KG-9094 £3.85 plus postage & packing**

With a range of about 5 metres, this kit will indicate using an LED when a person or object interrupts the infrared light beam. Use it across a doorway or across an assembly line.

- PCB dimensions: 20 x 30mm.
- 9-12VDC operation
- Kit supplied with Kwik Kit PCB, infrared transmitter/receiver diodes, & all electronic components.



## 50 METRE IR LIGHT BARRIER KIT

**KG-9196 £59.95 plus postage & packing**

Covering a distance of up to 50 metres this light beam relay is ideal for protecting areas that have wide entrances, including driveways, shops, offices and storerooms, etc. Once the beam is broken the relay will trigger and onboard LED will illuminate. The transmitter requires 9VDC power - use plugpack MP-3130 and the receiver requires 12VDC power - use plugpack MP-3011.

- Kit includes Kwik Kit PCB, infrared transmitter diodes, receiver transistor, magnifying lens and all electronic components.



## LED WATER LEVEL INDICATOR MKII KIT

**KC-5449 £10.25 plus postage & packing**

This simple circuit illuminates a string of LEDs to quickly indicate the water level in a rainwater tank. The more LEDs that illuminate, the higher the water level is inside the tank. The input signal is provided by ten sensors located in the water tank and connected to the indicator unit via-light duty figure-8 cable. Kit supplied with PCB with overlay, machined case with screenprinted lid and all electronic components.

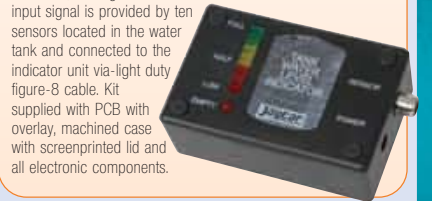

## FREE CATALOGUE

Checkout Jaycar's extensive range

We have kits & electronic projects for use in:

- Audio & Video
- Car & Automotive
- Computer
- Lighting
- Power
- Test & Meters
- Learning & Educational
- General Electronics Projects
- Gifts, Gadgets & Just for fun!

For your FREE catalogue log on to: [www.jaycarelectronics.co.uk/catalogue](http://www.jaycarelectronics.co.uk/catalogue) or check out the range at: [www.jaycarelectronics.co.uk](http://www.jaycarelectronics.co.uk)



0800 032 7241

[www.jaycarelectronics.co.uk](http://www.jaycarelectronics.co.uk)

**Jaycar**  
Electronics





**Editorial Offices:**  
EVERYDAY PRACTICAL ELECTRONICS EDITORIAL  
Wimborne Publishing Ltd., Sequoia House, 398a Ringwood Road,  
Ferndown, Dorset BH22 9AU  
Phone: (01202) 873872. Fax: (01202) 874562.  
**Email:** enquiries@epemag.wimborne.co.uk  
**Web Site:** www.epemag.com  
See notes on **Readers' Technical Enquiries** below – we regret  
technical enquiries cannot be answered over the telephone.  
**Advertisement Offices:**  
Everyday Practical Electronics Advertisements  
Sequoia House, 398a Ringwood Road, Ferndown, Dorset BH22 9AU  
Phone: 01202 873872 Fax: 01202 874562  
**Email:** stewart.kearn@wimborne.co.uk

### Seasons greetings

*EPE* is first and foremost a print magazine, but we know that for some of our readers, geography, or a simple preference for digital documents, means the web makes more sense. That is why for the last decade we have been leaders in supplying our publications online. It is appropriate therefore, that a decade after our digital version was launched, we have decided to bring together all the incremental improvements of the last ten years into a new, single streamlined website. Originally, we needed two – one for the UK and one based in the US for our international customers. Plus, we had an admittedly sprawling collection of download options for software and other projects. The good news is that our new, single website at [www.epemag.com](http://www.epemag.com) is not just easier to use, but also continues our tradition of innovation with many extra features such as a more intuitive download route in the 'Library' section, as well as plenty of up-to-date news and blogs.

If you enjoy the printed version of *EPE* then we feel sure that you will also appreciate the rich and varied content of [www.epemag.com](http://www.epemag.com). So, when you can't bear the thought of another plate of turkey this holiday, why not spend a pleasant hour or two exploring our website. This is just the briefest of overviews and Alan Winstanley has kindly provided more details in this month's *Net Work*.

Last, let me wish all our readers a very happy Christmas and a successful new year, from myself, our publisher Mike Kenward and the hard-working publishing team and regular contributors at Wimborne. In 2008, we had 12 excellent issues, packed with fascinating features, projects and news – and that is exactly what we have planned for 2009. So, wherever and however you read *EPE*, we look forward to providing you with the very best hobby electronics magazine.

*Mike*

**Editor:** MATT PULZER  
**Consulting Editors:** DAVID BARRINGTON  
JOHN BECKER  
**Subscriptions:** MARILYN GOLDBERG  
**General Manager:** FAY KEARN  
**Editorial/Admin:** (01202) 873872  
**Advertising and Business Manager:**  
STEWART KEARN (01202) 873872  
**On-line Editor:** ALAN WINSTANLEY  
**EPE Online** (Internet version) Editors:  
CLIVE (Max) MAXFIELD and ALVIN BROWN  
**Publisher:** MIKE KENWARD

### READERS' TECHNICAL ENQUIRIES

**Email:** techdept@epemag.wimborne.co.uk  
We are unable to offer any advice on the use, purchase, repair or modification of commercial equipment or the incorporation or modification of designs published in the magazine. We regret that we cannot provide data or answer queries on articles or projects that are more than five years' old. Letters requiring a personal reply must be accompanied by a stamped self-addressed envelope or a self-addressed envelope and international reply coupons. We are not able to answer technical queries on the phone.

### PROJECTS AND CIRCUITS

All reasonable precautions are taken to ensure that the advice and data given to readers is reliable. We cannot, however, guarantee it and we cannot accept legal responsibility for it. A number of projects and circuits published in *EPE* employ voltages that can be lethal. You should not build, test, modify or renovate any item of mains-powered equipment unless you fully understand the safety aspects involved and you use an RCD adaptor.

### COMPONENT SUPPLIES

We do not supply electronic components or kits for building the projects featured, these can be supplied by advertisers.  
We advise readers to check that all parts are still available before commencing any project in a back-dated issue.

### ADVERTISEMENTS

Although the proprietors and staff of *EVERYDAY PRACTICAL ELECTRONICS* take reasonable precautions to protect the interests of readers by ensuring as far as practicable that advertisements are bona fide, the magazine and its publishers cannot give any undertakings in respect of statements or claims made by advertisers, whether these advertisements are printed as part of the magazine, or in inserts. The Publishers regret that under no circumstances will the magazine accept liability for non-receipt of goods ordered, or for late delivery, or for faults in manufacture.

### TRANSMITTERS/BUGS/TELEPHONE EQUIPMENT

We advise readers that certain items of radio transmitting and telephone equipment which may be advertised in our pages cannot be legally used in the UK. Readers should check the law before buying any transmitting or telephone equipment, as a fine, confiscation of equipment and/or imprisonment can result from illegal use or ownership. The laws vary from country to country; readers should check local laws.

### AVAILABILITY

Copies of *EPE* are available on subscription anywhere in the world (see opposite) and from all UK newsagents (distributed by SEYMOUR). *EPE* can also be purchased from retail magazine outlets around the world. An Internet online version can be purchased and downloaded for just \$18.99US (approx £10) per year, available from [www.epemag.com](http://www.epemag.com)

### SUBSCRIPTIONS

Subscriptions for delivery direct to any address in the UK: 6 months £19.95, 12 months £37.90, two years £70.50; Overseas: 6 months £23.00 standard air service or £32.00 express airmail, 12 months £44.00 standard air service or £62.00 express airmail, 24 months £83.00 standard air service or £119.00 express airmail.

Online subscriptions, for downloading the magazine via the Internet, \$18.99US (approx £10) for one year available from [www.epemag.com](http://www.epemag.com).

Cheques or bank drafts (in £ sterling only) payable to *Everyday Practical Electronics* and sent to *EPE* Subs. Dept., Wimborne Publishing Ltd, Sequoia House, 398a Ringwood Road, Ferndown, Dorset BH22 9AU. Tel: 01202 873872. Fax: 01202 874562. **Email:** subs@epemag.wimborne.co.uk. Also via the Web at: [www.epemag.com](http://www.epemag.com). Subscriptions start with the next available issue. We accept MasterCard, Maestro or Visa. (For past issues see the Back Issues page.)

### BINDERS

Binders to hold one volume (12 issues) are available from the above address. These are finished in blue PVC, printed with the magazine logo in gold on the spine. Price £7.95 plus £3.50 p&p (for overseas readers the postage is £6.00 to everywhere except Australia and Papua New Guinea which cost £10.50). Normally sent within seven days, but please allow 28 days for delivery – more for overseas.

Payment in £ sterling only please. Visa, Maestro and MasterCard accepted. Send, fax or phone your card number, card expiry date, valid from date and card security code (the last 3 digits on or just under the signature strip), with your name, address etc. Or order on our secure server via our UK website. **Overseas customers** – your credit card will be charged by the card provider in your local currency at the existing exchange rate.



# NEWS

A roundup of the latest Everyday News from the world of electronics



## Bluetooth TV sync

Barry Fox reports that LG Electronics has hit entirely predictable problems with its new range of Bluetooth TV sets

THE PG7000 plasma and LG 7000 LCD TVs were announced for global launch at the German *IFA (Internationale Funkausstellung* – the world's largest consumer electronics trade fair) and promised a new feature: 'Bluetooth connection, which means that viewers can sync-up Bluetooth headphones to the set without any unsightly wires getting in the way, giving consumers the freedom to move around while watching their favourite programmes at maximum volume.'

Past experience of Bluetooth stereo immediately rang warning bells. Technology called A2DP (Advanced Audio Distribution Profile) is used to compress two hi-fi channels into the wireless space normally used for mono phone sound. The compression, decompression and coding process delays the sound. So the sound heard through headphones lags behind lip movements seen on screen.

### Lip service

Motorola was first to suffer from this in 2005, with the DC800 Bluetooth Stereo Transceiver which lets the user listen to a TV through headphones. But the sound was

severely delayed and lip sync destroyed. Three years later Motorola admits it is still looking for 'enhancements to improve the user experience.' The DC800 is hard to find for sale.

"We led the industry in providing such connectivity", Motorola said recently, before grudgingly admitting. "When you use the Motorola DC800 connected to your TV with a Motorola stereo Bluetooth headset you enjoy a rich stereo experience without wires ... (but) it can create the feeling that the audio is slightly out of time to the picture."

I asked LG whether its engineers had solved the 'lip sync' problem, and if so how. After much delaying, LG finally confirmed that as a result of my query the company had tested the sets and found a 'slight delay'. This, said LG, is on "pre-production Bluetooth enabled screens, and once the main production units arrive they will be tested and if the delay is still there appropriate action will be taken, such as firmware updates."

Marketing manager George Mead said: "When we got your question we tested one in our show room and noticed a slight lag in the sound behind the pictures on screen. We need to rectify this. We are working on it. It's

a key factor. We will do everything possible to eliminate it. We have two or three weeks before the sets go on sale. We may be able to adapt the system already used to adjust lip-sync on our Blu-ray players and AV products. We are looking at firmware updates to the TVs."

LG promised to keep me 'in the loop' on progress. But after two months I had still heard nothing and the TVs have now gone on sale. It is too early to know whether users are now being puzzled by lip movements and speech that are slightly out of step.

How is it possible, you may ask, for a company with the engineering skill of LG to overlook such a basic issue of lip sync?

The answer may be that all the design work was done in Korea, and Korean engineers, like Japanese engineers, are accustomed to seeing TV programmes and movies which have often been dubbed from a Western language and are inherently out of sync.

When Panasonic produced a Blu-ray disc to demonstrate the audio video potential of the new BD format, shots of singer Katherine Jenkins were painfully out of sync. But no-one from Panasonic seemed to have noticed.

## COMPONENT SUPPLIES

Following the publication of Brian Williams' letter in *Readout* Nov '08 about unobtainable components, reader Ben Rawles has advised us that he and his wife Joanne have set up 'BJ Electronics' which they believe will be of service to *EPE* readers. They have created a modest shop at [www.bjelectronics.co.uk](http://www.bjelectronics.co.uk) and have bought a number of components which they are prepared to resell and charge the minimum possible for P&P. They plan to purchase more components which they believe will also be suitable for *EPE* readers.

## Kill A Watt!

The Kill A Watt family of products allows both home and business users to cut energy costs and find out which electrical devices, appliances and components are affordable to keep plugged in. Simply connect an appliance to the Kill A Watt device of choice and it will assess how energy efficient (or not) that appliance really is. An LCD display counts consumption by the kilowatt-hour, the same as your local utility.

The Kill A Watt Electricity Meter is an economical and simple tool to assess the efficiency of your electric appliances. The large LCD display shows the power consumption of the appliance by kilowatt-hours. It can calculate the electricity cost of the appliance by the day, week, month, or year. More information is available at: <http://cableorganizer.com/kill-a-watt/>

The Kill A Watt EZ electricity usage monitor allows you to determine which

machines are actually worth keeping in use. This device allows you to unplug the appliance and still see the readings. It also allows you to input your local k/Wh rates so that it can tell you exact figures rather than just a k/Wh reading. It is claimed to be accurate to within 0.2%. More information: <http://cableorganizer.com/kill-a-watt-ez/>.

The Kill A Watt PS – protect your valuable electronic equipment and appliances with this innovative power strip bundled with an electronic measuring device. In addition to protecting valuable electronics from power surges and spikes, this strip will actually measure how energy efficient they are, allowing you to calculate your overall electrical costs. The strip has six standard-sized outlets and two extra wide outlets for those extra large plugs. More information: <http://cableorganizer.com/kill-a-watt-ps/>.

For more general information browse [www.sevic.com](http://www.sevic.com).

## Microchip's LIN/SAE J2602 Transceivers

Microchip has introduced the LIN/SAE J2602 automotive-certified transceivers. The new devices are third party LIN/J2602 approved, OEM approved and AEC-Q100 certified to meet the stringent requirements of global automotive manufacturers worldwide. The transceivers include built-in voltage regulators and are compliant with the LIN Bus 2.0/2.1 and SAE J2602 standards, as well as the previous-generation LIN 1.X standards.

Microchip says that the market momentum for LIN remains strong in all major product areas. According to the research firm Strategy Analytics, LIN represents the second largest market segment in networked automotive applications in terms of number of nodes. The MCP202X family represents Microchip's second generation of LIN/SAE J2602, following the company's previous generation MCP201 family.

The MCP202X transceivers, with their built-in voltage regulator, reduce the number of external components needed and transceivers' proven robustness and world-class ESD performance enable reliable communication in even harsh environments. Additionally, the devices' low emissions eliminate the need for external shielding, which is of particular interest to noise-sensitive systems. Low power consumption in operational and standby modes (115 and



16 microamps, respectively) makes the MCP202X transceivers suitable for non ignition-switched applications, and helps extend battery life.

Three low-cost development tools are available to help designers get started. The PICDEM™ CAN-LIN 3 Demonstration Board (DM163015) for \$199.99, the ECANT/LIN PICtail Plus Daughter Board

(AC164130) for \$45.00 and the LIN Serial Analyser (APGDT001) for \$64.95; all are available from [www.microchipdirect.com](http://www.microchipdirect.com).

The MCP2021 transceiver is available in 8-pin SOIC, PDIP and 4mm × 4mm DFN packages. The MCP2022 transceiver is available in 14-pin SOIC, TSSOP and PDIP packages. Samples are available at: <http://sample.microchip.com>.

## Europe's science and engineering labour base

The number of science graduates has been declining over most of Europe, but there are no short-term solutions to reverse a trend that threatens the continent's longer term prosperity and competitiveness. This established drain away from science and engineering taking place both at university level and afterwards among young researchers can only be reversed by better understanding of the forces and trends within the global S&E (science and engineering) workforce and labour market as a whole. To do this, the European Science Foundation (ESF) is helping set up a research community dedicated to studying the S&E labour market, kicking off with a recent exploratory workshop, The Labour Market for Scientists and Engineers.

The workshop was unusually broad in its scope, aiming to identify how the S&E labour market has been changing and what impact this has on recruitment, motivation and work satisfaction, according to its co-convenor Andries de Grip. "We focused on both theoretical and empirical research covering various aspects of the labour markets for scientists and engineers", said de Grip. "In order to include several perspectives on the S&E labour market, we brought together scholars of different disciplines such as labour economics, the economics of innovation, industrial organisation, management sciences."

The workshop was divided into five sessions to cover all this ground: entering the labour market; human capital and careers; labour mobility; researcher performance; R&D workers in industry.

The workshop kicked off on the labour market for scientists and engineers with a keynote presentation by Professor Richard Freeman, a leading economist from Harvard University in the US, on the globalisation of the labour market for scientists and engineers. "Freeman stated that policy makers do not seem to be fully aware of the fact that scientists and engineers are the key actors in innovation, and will therefore be crucial for the future competitiveness of developed countries, which is at risk in both the US and Europe," said de Grip.

The second session focused on the development of careers, using case studies from several countries. The third session dealt with core issues from a policy perspective, and the labour mobility of scientists and engineers, concluding with a key discussion about factors determining migration of science and engineering graduates within EU member states.

The fourth session then went further by drilling down more into the key factors affecting performance of scientists, and how these vary between region and gender.

The last session then addressed questions relating to salary levels and motivation, for example whether job satisfaction can compensate for relatively low rates of pay within R&D.

The workshop concluded with a sense of the urgent need to address issues of motivation and recruitment in the S&E workforce, with discussions on future cooperation and follow ups, and crucially the proposal for an ESF Research Networking Program on the subject.

Richard Freeman also proposed to establish co-operation between the European researchers and the Science & Engineering Workforce Project (SEWP) at the National

Bureau of Economic Research (NBER) of which he is the director. The workshop has been a good start for this co-operation.

## INTELLIGENT BROADBAND GATEWAYS

2Wire, a provider of broadband solutions, recently announced that BT (British Telecom) has begun deploying 2Wire HomePortal intelligent gateways to connect subscribers to BT's new super-fast, fibre-based broadband network. BT's deployment of fibre to the premises, services at Ebbsfleet is the first step of the BT Next Generation Access (NGA) strategy.

BT's fibre-based, super-fast broadband network will give subscribers enough speed to run multiple bandwidth-hungry applications. For example, some members of a family could be watching different high-definition (HD) movies at the same time, others are gaming or working on complex graphics or video projects. The new services will also offer substantially improved 'upstream' speeds, allowing customers to post videos, use hi-def video conferencing, and enjoy interactive HD gaming.

The 2Wire HomePortal 2701 HGV is a TR-069 standard-compliant intelligent residential gateway that features simplified self-installation, an advanced ADSL2+ modem, an Ethernet network interface, a powerful HyperG wireless router for whole-home wireless coverage, support for Internet telephony (VoIP) to enable a robust voice and data solution, and a professional grade firewall for enhanced security. The gateway also enables multiple users to wirelessly share access to the Internet while sharing files, printers, and networked applications with every networked device in the home.

# 1000:1 UHF Prescaler for Frequency Counters



By JIM ROWE

**Here's a high speed prescaler, which can extend the range of virtually any frequency counter to over 2.8GHz. It divides frequencies by exactly 1000, so gigahertz can be read directly on megahertz displays.**

**N**OT ALL THAT long ago, almost the only items of domestic equipment operating on a frequency above 1GHz were microwave ovens, all of which use a magnetron operating at 2.45GHz (the frequency which causes maximum heating of water molecules). But nowadays, all kinds of equipment transmit and/or receive at frequencies above 1GHz. For example, many cordless phones operate at frequencies around 2.4GHz, sharing these frequencies with wireless CCTV cameras, AV transmitters and receivers, security systems, remote access locking systems and baby monitors.

Other items using frequencies in the 2.4GHz region include 'WiFi' (802.11b and 802.11g) computer networking gear and 'Bluetooth' wireless links for

computer peripherals (802.11a wireless networking equipment operates on even higher frequencies, at about 5GHz).

Then there are wireless internet service providers, which mainly use frequencies around 1.9GHz or 2.6GHz and there are '3G' digital mobile phones, which operate on frequencies of around 2.1GHz in metropolitan areas. We mustn't forget GPS receivers either. These operate on frequencies of 1.57542GHz and 1.2276GHz.

## Checkout

So how can you check the operating frequency of any of these devices, when the range of most reasonably-priced frequency counters only extends up to 1GHz? Well, you can either fork out

the dough to buy another counter that is capable of measuring up to 3GHz or so, or you can build yourself the UHF Prescaler described here.

This simply connects 'in front' of your existing counter and divides the frequency of the signals you want to measure by exactly 1000. So 1.5GHz becomes 1.5MHz, 2.45GHz becomes 2.45MHz and so on, allowing you to read the incoming frequency directly and without any mental arithmetic.

The Prescaler uses some special high speed ECL (emitter-coupled logic) ICs to perform the 1000:1 frequency division and these are able to operate at input frequencies up to at least 2.8GHz. And because the output frequency of the Prescaler is still only 2.8MHz for an input of 2.8GHz, this means that it should be suitable for extending the range of just about any counter. In fact, it would be a good companion for the 50MHz Frequency Counter described in the November '08 issue of *EPE*.

So, if you want to be able to measure frequencies up to at least 2.8GHz with your trusty old lower frequency counter, this project is for you. All of

the components and circuitry are on a single PC board, and although there are quite a few very small surface mount parts to fit on the board, this isn't unduly difficult providing you take it slowly and carefully. You will, of course, need a soldering iron with a very fine chisel-shaped bit, plus steady hands and an illuminated magnifier to help you see what you're doing.

We'll also give you a few tips on manual soldering of SMDs (surface mount devices) in an accompanying panel.

## How it works

In terms of its basic operation, the UHF Prescaler is pretty straightforward, as you can see from the block diagram of Fig.1. The incoming UHF signals are first passed through wideband input amplifier IC1, to make the Prescaler reasonably sensitive. The boosted signals then pass through a high-speed divide-by-four stage using IC2, which is basically a pair of very fast ECL flipflops in cascade.

The output of IC2 then passes to IC3, which is another very fast ECL counter programmed to divide by 125. So the output from IC3 is a signal with a frequency 1/500th that of the UHF input signal.

Because the output of IC3 is in the form of very narrow pulses, we then pass them to IC4. This is an ECL JK flipflop, connected here not only to divide the frequency by a further factor of two, but also to provide square-wave outputs so they're more suitable for triggering low-frequency counter input circuitry. Then, to make the outputs even more compatible with virtually any common frequency counter or scope, we finally pass them through a simple logic level interface stage using transistors Q1 and Q2.

## Circuit description

For a more detailed understanding of the Prescaler, let's refer now to the main circuit diagram – see Fig.2.

The UHF signal to be measured enters via CON1 and first passes through an input termination and overload protection circuit formed by two 100Ω resistors and diodes D1 and D2. The two resistors are in parallel to provide an input termination of 50Ω, while D1 and D2 are 1PS70SB82 very low capacitance Schottky barrier diodes,

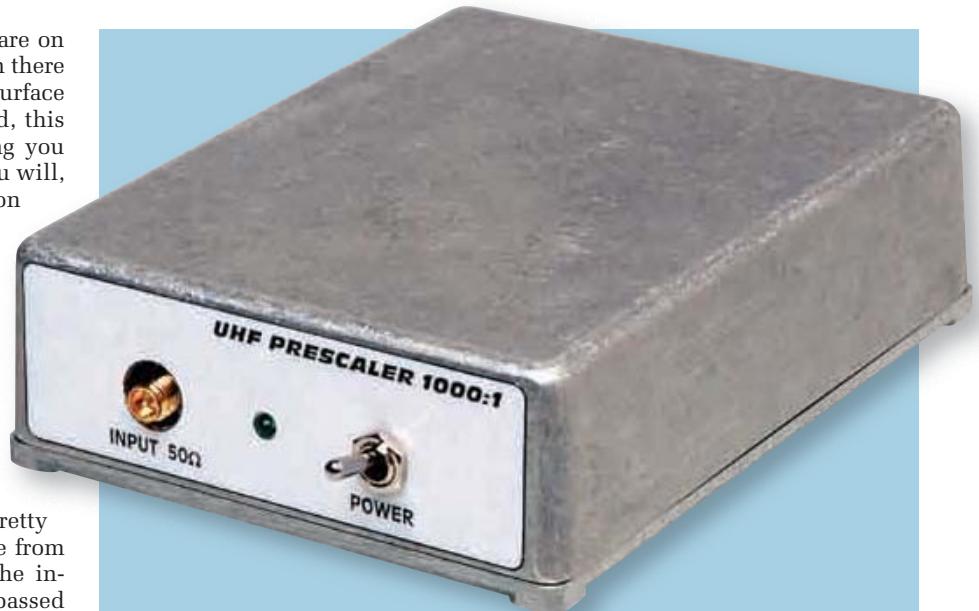

The UHF Prescaler circuit is housed in a standard diecast aluminium instrument case, which provides the necessary shielding from stray signals.

which have a very low forward voltage drop. Because they're connected in inverse parallel, they limit the input signal level to no more than 2V peak-to-peak.

The signal is then coupled to the input of IC1 via a 10nF capacitor. IC1 is a Mini-Circuits ERA-2SM monolithic broadband amplifier device, with about 12dB of gain up to over 5GHz. IC1 is fed with DC power via its output (pin 3), with the 47Ω resistor chosen to set the correct operating current.

As the power feed is effectively in parallel with the output of IC1, choke RFC3 is used to provide a reasonable load. This choke is a Mini-Circuits ADCH-80A, a special very wideband device chosen because it has a very low parasitic capacitance and is therefore not self-resonant at frequencies below about 8GHz.

The boosted signal is fed from the output of IC1 to the clock input of IC2

via another 10nF capacitor. By the way, it's the value of the coupling capacitors at the input and output of IC1 which determine the lowest frequency that the Prescaler will work at.

The 10nF capacitors, as shown, allow it to work down to below 50MHz. The reason why we don't use larger values to extend the range even lower down is that larger value capacitors tend to self-resonate at frequencies below 4GHz – which we don't want because it would lower the maximum frequency of operation.

## Frequency divider

IC2 is our first and most critical frequency divider and it's an MC10EL33 device from On Semiconductor. This is an ECL divide-by-four device, with very impressive specifications. It can operate at input frequencies up to at least 3.8GHz and has a propagation delay of less than 800ps (picoseconds!).

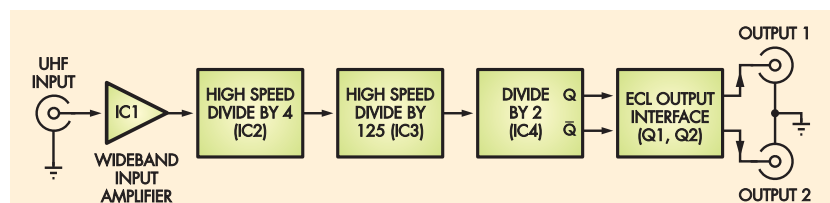

Fig.1: the block diagram for the UHF Prescaler. The incoming signal is first amplified and then divided by 1000 using IC2, IC3 and IC4. It is then fed to two separate output sockets via transistors Q1 and Q2.

## Parts List – UHF Prescaler

1 double-sided PC board, code 697, available from the <i>EPE PCB Service</i> , size 81 × 111mm	1 MC10EL35 high speed ECL JK flipflop (IC4)
1 diecast aluminium box, (119 × 93.5 × 34mm)	1 7805 +5V 3-terminal regulator (REG1)
1 reverse polarity PC-mount SMA socket (CON1)	2 PN200 PNP transistors (Q1,Q2)
2 PC-mount BNC sockets (CON2, CON3)	1 3.3V 1W Zener diode (ZD1)
1 PC-mount 2.5mm concentric DC connector (CON4)	1 3mm green LED (LED1)
1 PC-mount DPDT toggle switch (S1)	2 1PS70SB82 UHF Schottky diode (D1,D2)
2 10 $\mu$ H RF chokes (RFC1, RFC2)	1 1N4004 1A diode (D3)
1 ADCH-80A UHF wideband RF choke, SMD (RFC3)	
1 TO-220 heatsink, 6073 type (19 × 19 × 9.5mm)	
1 12 × 12mm aluminium sheet (1mm thick)	
1 small quantity of thermal grease	
1 M3 × 6mm round-head machine screw	
6 M3 × 15mm countersink machine screws	
6 6mm-long untapped metal spacers	
7 M3 nuts and star lockwashers	
<b>Semiconductors</b>	<b>Capacitors</b>
1 ERA-2SM UHF monolithic amplifier (IC1)	1 2200 $\mu$ F 16V RB electrolytic
1 MC10EL33 high speed divide-by-four ECL divider (IC2)	1 10 $\mu$ F 16V RB electrolytic
1 MC10E016 high speed ECL programmable counter (IC3)	1 4.7 $\mu$ F 16V tantalum
	3 100nF multilayer monolithic ceramic (leaded)
	6 100nF X7R dielectric 1206 SMD chip
	8 10nF X7R dielectric 1206 SMD chip
	<b>Resistors (0.25W 1%)</b>
	2 2.2k $\Omega$ 0805 SMD chip
	1 430 $\Omega$
	1 330 $\Omega$
	2 300 $\Omega$
	1 120 $\Omega$
	2 100 $\Omega$ 0805 SMD chip
	2 100 $\Omega$
	1 75 $\Omega$
	2 56 $\Omega$ 0805 SMD chip
	3 51 $\Omega$
	1 47 $\Omega$ 0805 SMD chip

## Specifications

This UHF Prescaler is a high-speed frequency divider designed to extend the range of low-frequency counters to at least 2.8GHz. It divides the input frequency by a factor of 1000, so GHz (gigahertz) may be read directly in MHz (megahertz). There are two independent outputs, both compatible with the input of virtually any frequency counter or oscilloscope.

Maximum input frequency.....	2.8GHz minimum
Minimum input frequency.....	50MHz maximum
Input sensitivity .....	less than 250mV peak-peak
Input impedance.....	50 $\Omega$
Output level .....	875mV peak-peak
Output impedance.....	75 $\Omega$
Power requirement .....	9V DC
Current drain.....	190mA
Power dissipation .....	1.7W

It even includes its own bias voltage source (V<sub>bb</sub>, pin 4) which is used to provide the correct ECL bias for its two inputs (via the 2.2k $\Omega$  resistors).

IC2 has complementary outputs (pins 7 and 6) which both need to be tied to ECL low logic level via termination resistors of close to 50 $\Omega$ . Here we use 56 $\Omega$  chip resistors, because this value is more readily available than 51 $\Omega$ .

From pin 7 of IC2 the signal (now 1/4 the input frequency) passes directly to the clock input of IC3, an MC10E016 ECL 8-bit programmable synchronous binary counter, able to count/divide input frequencies up to at least 700MHz.

We have programmed it to divide by 125, by tying its parallel load inputs (P0-P7, pins 3-7 and 21-23) to the appropriate ECL logic levels. For division by 125, we set the parallel inputs to the binary code for 256 – 125, or 131: ie, 1000011. Note that the ECL high or ‘1’ level is established by the 75 $\Omega$  and 430 $\Omega$  resistors, forming a voltage divider across the 5V supply rails.

The output signal from IC3 (1/500 of the input frequency) appears at the terminal count or  $\overline{TC}$  pin (19), which must also be tied to the ECL logic low level via a terminating resistor (here 51 $\Omega$ , because it’s a standard leaded part). The ECL logic low level is established by ZD1, a 3.3V Zener diode.

By the way, if you’re wondering where the current for ZD1 comes from, to establish the nominal 3V level, it’s sourced from the various ECL outputs tied to it via the termination resistors, plus the inputs of IC3 that are connected directly.

As mentioned earlier, the output signal from IC3 is low in frequency (below 8MHz) but it’s in the form of very narrow pulses which would probably pose problems for the input circuitry of many low-frequency counters. That’s why we don’t program IC3 to divide by 250 (which is easily done).

Instead, we program it to divide by 125 and feed its output to a third ECL device, IC4. This is an MC10EL35, a very fast JK flipflop with its J and K inputs tied to ECL logic high level so it operates in toggle mode as a divide-by-two counter.

So, at the complementary outputs (pins 7 and 6) of IC4 we finally get output signals of exactly 1/1000th the input frequency and, just as importantly, in the form of symmetrical square waves, which are much more

compatible with typical counter input circuits. The outputs of IC4 are again tied to ECL logic low level via 51Ω terminating resistors.

## Output interface

Since the outputs from IC4 are still switching between ECL levels (nominally +3V and +4V), the remaining step is to pass them through a level translation and output buffer/interface circuit, to provide them as buffered low-impedance signals referenced to ground. This job is performed by transistors Q1 and Q2, connected as a differential switch. This has the advantage that it allows us to easily provide the Prescaler with two independent outputs, so that it can drive either two different counters or perhaps a counter and an oscilloscope.

Because all the Prescaler circuitry operates from a single 5V DC supply, the power supply is very straightforward and involves only a 7805 regulator (REG1), driven from an external 9V DC plugpack. Although the total current drain is about 190mA, giving a regulator dissipation of about 800mW, the regulator is provided with a small heatsink, keeping it reasonably cool.

## Construction

As you can see from the photos, all the Prescaler circuitry is on a double-sided PCB board measuring 111 × 81mm. This board is available from the *EPE PCB Service*, code 697. The PCB component layout is shown in Fig.3. The board has rounded cutouts in each corner so that it fits snugly inside a standard diecast aluminium instrument case, measuring 119 × 93.5 × 34mm. It's actually mounted on the box lid, which forms the Prescaler's base.

All the connectors, power switch S1 and the power indicator LED (LED1) are mounted on the top of the board, along with the regulator (on its heatsink), transistors Q1 and Q2 and the other leaded components. The surface-mount ICs and other components are mounted on the underside of the board.

There are quite a few connections between the two copper layers of the board, but these are unlikely to pose a problem, even if you don't get a board with plated-through holes. Some of the connections are achieved simply by soldering the leaded component leads on both top and bottom, while the others

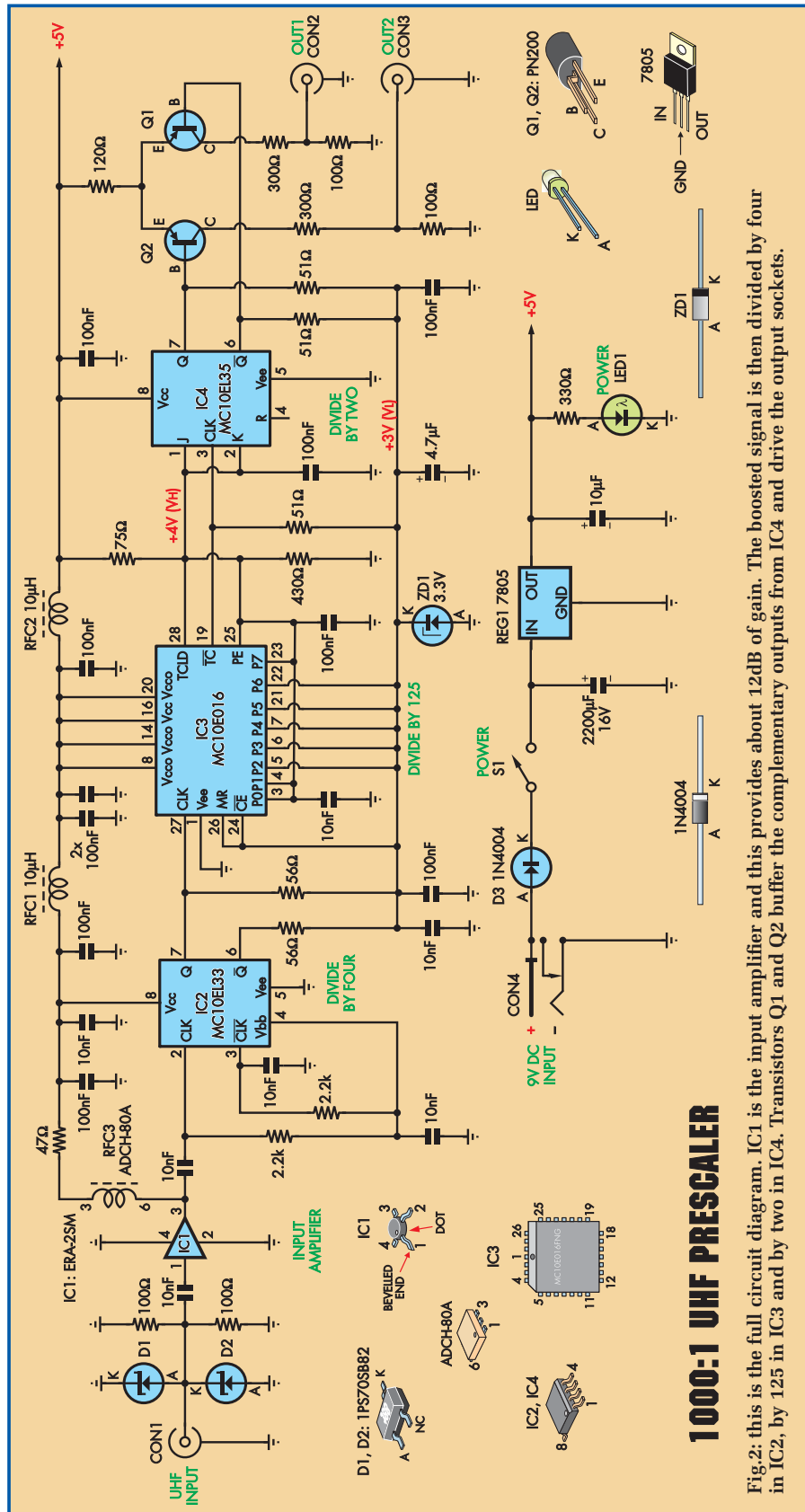

Fig.2: this is the full circuit diagram. IC1 is the input amplifier and this provides about 12dB of gain. The boosted signal is then divided by four in IC2, by 125 in IC3 and by two in IC4. Transistors Q1 and Q2 buffer the complementary outputs from IC4 and drive the output sockets.

## 1000:1 UHF PRESCALER



# Constructional Project

Reproduced by arrangement with  
SILICON CHIP magazine 2008.  
www.siliconchip.com.au

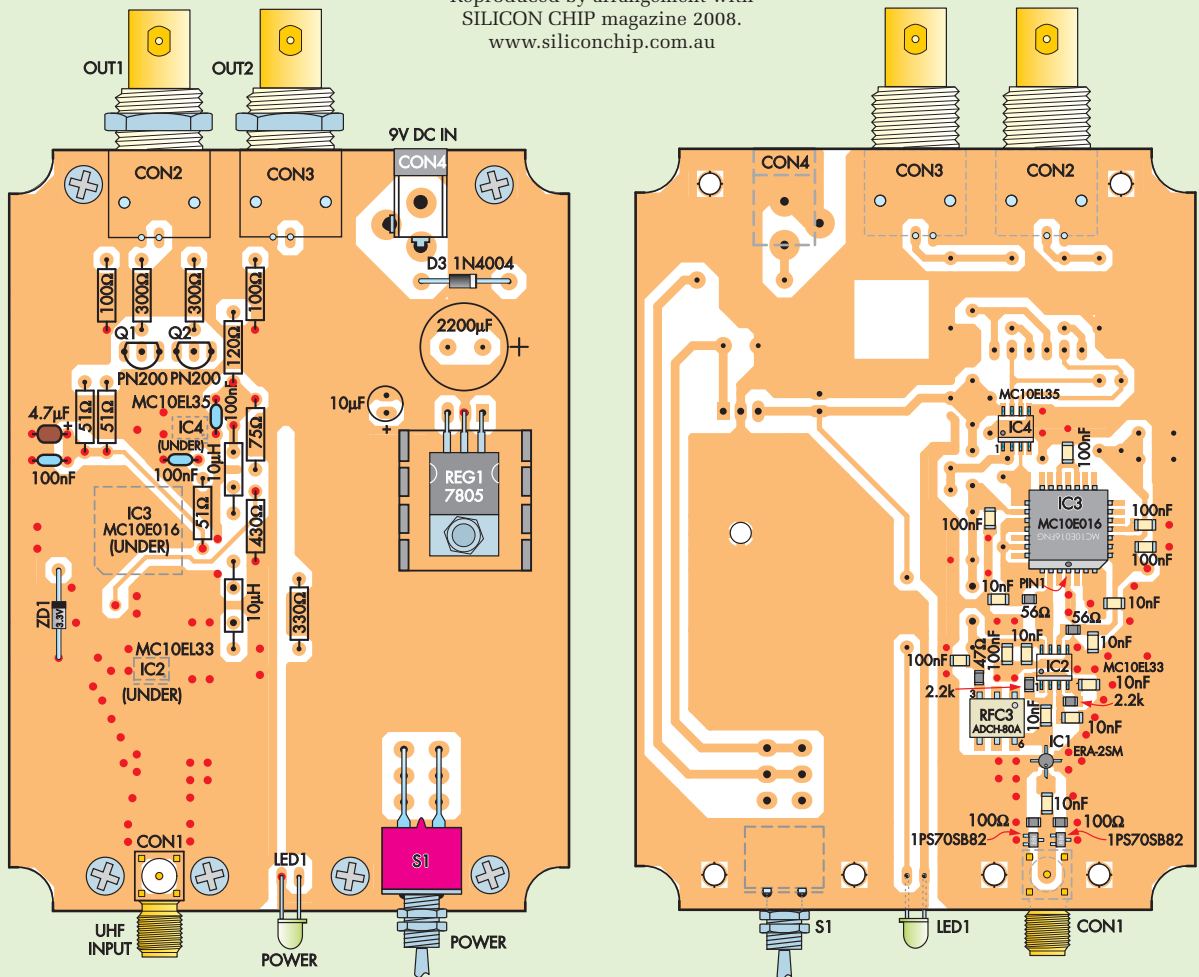

Fig.3: install the parts as shown in these two diagrams. The red dots show where you have to solder on both sides of the board and where to install vertical wire links (but only if your board isn't supplied with plated-through vias).

are mostly 'vertical links' between the upper and lower groundplane copper areas. These links are easy to make using short lengths of tinned copper wire (eg, resistor and diode lead offcuts).

The location and orientation of all the parts on both sides of the board are shown clearly in the two PC board overlay diagrams of Fig.3, so you shouldn't have any problems if you use these and the photos as a guide.

Since there are quite a few surface-mount parts (SMDs) to fit on the board, as well as the leaded parts, we recommend that you assemble everything in the order set out below.

First, fit the various connectors to the top of the board, beginning with CON1, which is a reverse polarity SMA socket. Follow this with CON2 and CON3 (the BNC sockets) and finally the DC power input socket (CON4).

That done, fit the DPDT power switch (S1).

### Fitting the SMDs

Next, turn the board over and lay it 'bottom copper up' on your workbench – use a small block of wood or plastic if necessary to support it. This will then allow you to fit all of the surface-mount devices with a minimum of obstruction. Fit the chip resistors first, then the input protection diodes (D1 and D2), the ICs and RFC3.

We have prepared an accompanying two-page panel with some diagrams to guide you in manual soldering of the various SMD parts. There's also a photo of a small rotary 'SMD work table', which you might like to duplicate. We also recommend the use of a magnifier lamp – ie, the

type that's fitted to an articulated, spring-loaded arm.

After you've fitted all of the SMD parts, the board can be turned over again and the smaller leaded parts fitted, including the resistors, RFC1 and RFC2 and the small capacitors. As mentioned earlier, some of the leads of these parts are used to make connections between the top and bottom copper – so remember to solder these leads on both sides. They're identified with a red dot on the PC board overlay diagrams of Fig.3.

If your PC board is not provided with plated-through-hole vias, there will also be quite a few 'vertical links' to fit, to provide low impedance links between the top and bottom copper. These are also identified on the overlay diagrams with a red dot, so don't forget them. They can be made using resistor or diode lead

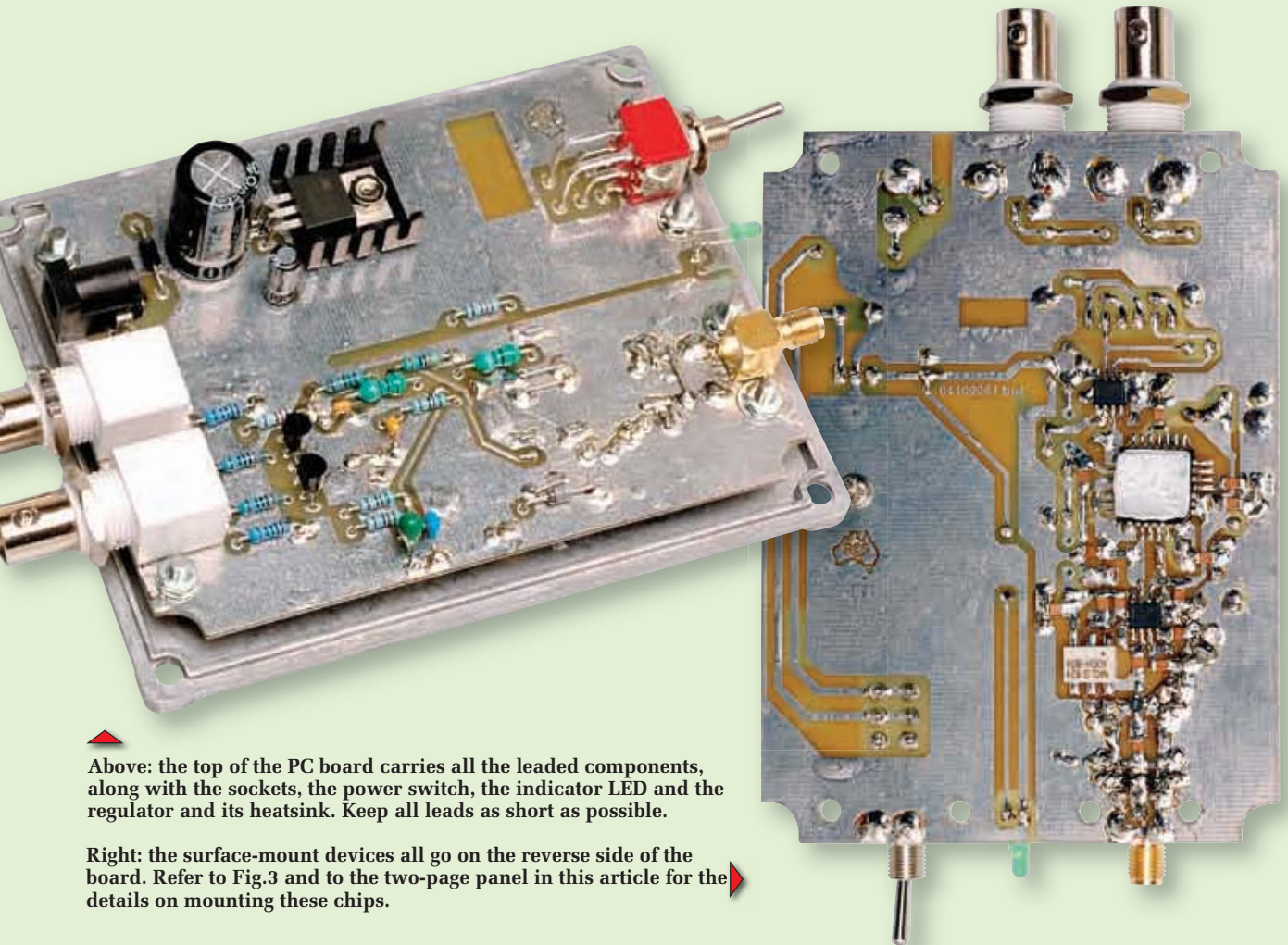

**Above:** the top of the PC board carries all the leaded components, along with the sockets, the power switch, the indicator LED and the regulator and its heatsink. Keep all leads as short as possible.

**Right:** the surface-mount devices all go on the reverse side of the board. Refer to Fig.3 and to the two-page panel in this article for the details on mounting these chips.

off-cuts – just don't overheat or dislodge any of the SMD parts nearby when you're soldering them in place.

Next, fit LED1, the Prescaler's power indicator. This mounts in the front centre of the board, with its leads bent forwards by 90° so that it lines up with

CON1 and switch S1. Position it so that it will later protrude through its mating hole in the front panel.

The final parts to fit are power diode D3, the two electrolytic capacitors and regulator REG1. As shown on Fig.3 and in the photos, the regulator

mounts flat against a small 6073 type TO-220 heatsink and this assembly is secured to the board using an M3 × 6mm screw and nut. Tighten the screw *before* soldering the regulator's leads, to avoid stressing the solder joints.

*continued on page 18*

## Table 1: Resistor Colour Codes

□	No.	Value	4-Band Code (1%)	5-Band Code (1%)
□	1	430Ω	yellow orange brown brown	yellow orange black black brown
□	1	330Ω	orange orange brown brown	orange orange black black brown
□	2	300Ω	orange black brown brown	orange black black black brown
□	1	120Ω	brown red brown brown	brown red black black brown
□	2	100Ω	brown black brown brown	brown black black black brown
□	1	75Ω	violet green black brown	violet green black gold brown
□	2	56Ω	green blue black brown	green blue black gold brown
□	3	51Ω	green brown black brown	green brown black gold brown

## How to manually solder SMD parts

Many surface-mount devices or SMDs are very small – the 0805 size chip resistors are only  $2 \times 1.3\text{mm}$ , while 1206 size chip capacitors are only slightly larger at  $3 \times 1.5\text{mm}$ . Many SMD IC packages have leads spaced only  $1.27\text{mm}$  apart. SMDs are not really designed for manual assembly, but it's quite feasible to fit many of the more common types by hand if you take care and use the right tools.

For a start, your soldering iron should be fitted with a fine chisel-point tip, which should be well tinned and kept as clean as possible. Ideally, it should be of the low-power temperature-regulated type. You also need to use fine-gauge resin-core solder – ideally, no more than  $0.8\text{mm}$  in diameter.

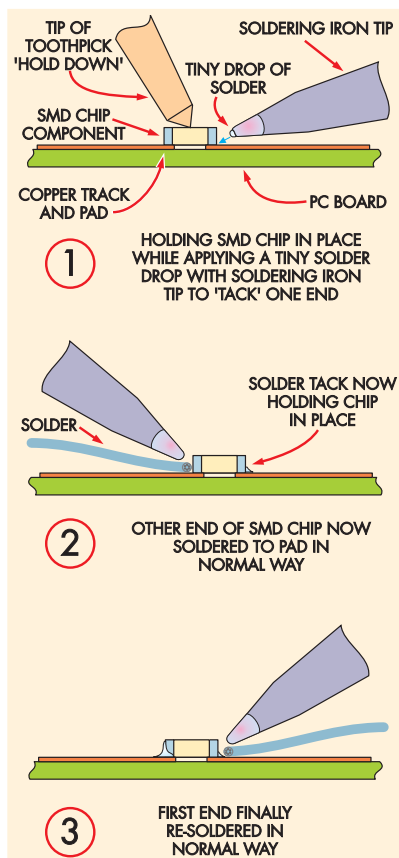

**Fig.7:** 0805 and 1206 size SMD chips can be soldered into position with the aid of a toothpick (to hold the device in position) and a soldering iron with a fine tip.

It really helps if your PC board has the copper pads solder-plated, as this makes it much easier to fit the SMD parts.

Manual assembly of SMDs is also a lot easier if the board is held horizontal and level, as the parts are less likely to move out of position while you're soldering them. In many cases, you can simply place the board flat on your workbench copper side up, although if there are leaded parts already mounted on the other side of the board you may need to support it using small blocks of wood, plastic or metal.

Because it often helps to be able to rotate the board for easier soldering at each end or side of an SMD, I made up a small rotary work table by adapting a ball-bearing swivel base from an industrial castor wheel assembly. By removing the wheel and axle and then bending the upper ends of the fork sides outwards at  $90^\circ$ , I made a fairly sturdy rotating bracket (it even has a brake lever, which can be used to lock the table and prevent it from rotating).

The swivel flange was then attached to a block of aluminium to serve as a base, while a  $120\text{mm}$  square of  $4\text{mm}$  aluminium sheet was fashioned into an octagonal plate with a  $6\text{mm}$  centre hole and  $3/16\text{-inch}$  holes tapped in each 'corner' for fastening board clamp screws. Two further holes were also drilled in the plate to line up with the former axle holes in the bent-over fork ends, so the plate could be bolted to the top of the fork to form the actual operating table, with its centre hole directly over the centre axis of the base swivel.

You can see the basic construction in the photos, which also show three of the support blocks and clamp brackets I fashioned to hold boards in place. Also visible is a pair of modified crossover tweezers mounted on a pivoting arm arrangement, which can be used to hold some SMDs in place while they are soldered – a kind of 'third hand'.

Such a work table is not necessary for all SMD work, but it might be worth considering if you're likely to be building up quite a few projects.

Another useful accessory for manual SMD work is an illuminated magnifier – a magnifying glass about  $120\text{mm}$  in diameter surrounded by a circular

fluorescent lamp in a metal hood that's mounted on an articulated, spring-loaded arm attached to a swivel base (so you can position it easily just above the operating table). They're not cheap, but if you're likely to be doing a fair bit of manual SMD or just fine PC board assembly, they are a good investment.

### One at a time

Before we go any further, here's an important tip: when you have quite a few SMDs to solder to a board, handle them one at a time. If you try to tackle more than one at a time, it's all too easy to accidentally send one or more flying off while you're concentrating on soldering the first one in position.

To handle tiny 0805 and 1206 size SMD chips and bring them to the board, use a small pair of stainless steel cross-over tweezers. They're available in almost any bargain store, either alone or in sets of tweezers for about £2. Having brought each part to the board, release it from the tweezers and carefully nudge it into position over its mating copper pads, using either the tip of the same tweezers or the point of a small wooden toothpick.

That done, hold the part in position using either the toothpick or a pair of modified crossover tweezers as a clamp, while you clean the soldering iron tip and then melt a very small amount of solder onto its end. The tip is then brought up to one end of the SMD, at a fairly low angle so the tiny drop of solder comes into contact with both the board copper and the end of the SMD (see Fig.7). The iron tip is only in contact for about half a second – just long enough to allow the drop of solder to tack-bond the two together and hold the SMD in place.

The toothpick or tweezers can now be removed and you can solder the other end of the SMD in the more 'normal' fashion before returning to the first end and quickly re-soldering it properly as well. The sequence is shown in Fig.7.

The same basic approach can be used with SMD diodes, transistors and ICs, with slight variations to suit the various packages. The idea is to hold

the SMD in position using a toothpick or crossover tweezer clamp while you tack-solder one of its leads to hold it in place. That done, you can remove the clamp and solder all of the remaining leads properly – and finally, the first lead again. Doing this is much the same whether the SMD has flat horizontal leads emerging from underneath, S-shaped leads that bend outwards at the bottom or J-shaped leads that bend inwards and underneath. Fig.8 shows the idea.

About the only kind of SMD package you can't solder in this way is the type with no leads at all – just 'solder bumps' underneath. These really aren't suitable for manual soldering.

One last tip: whether you're soldering SMD chip resistors, capacitors or other devices like diodes, transistors and ICs, make all joints as quickly as possible, while at the same time taking care to make a good joint. The faster you make the joint, the lower the risk of damaging the SMD by overheating (which is very easy to do, since they're so tiny). Also, use the smallest amount of solder necessary to make a good joint – the less solder you use, the lower the risk of accidentally bridging between device leads with a blob of excess solder.

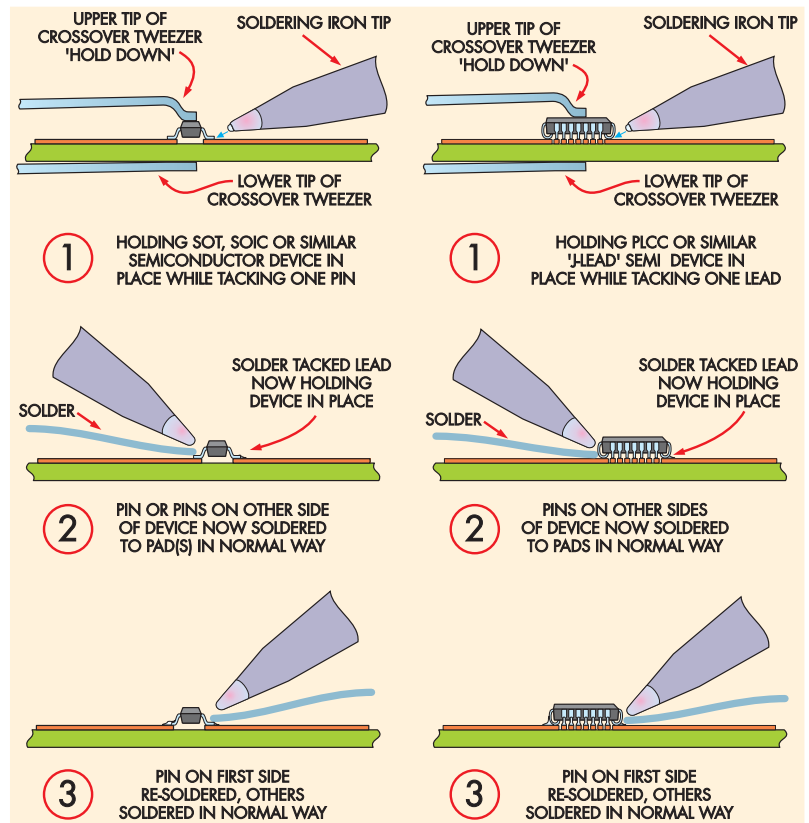
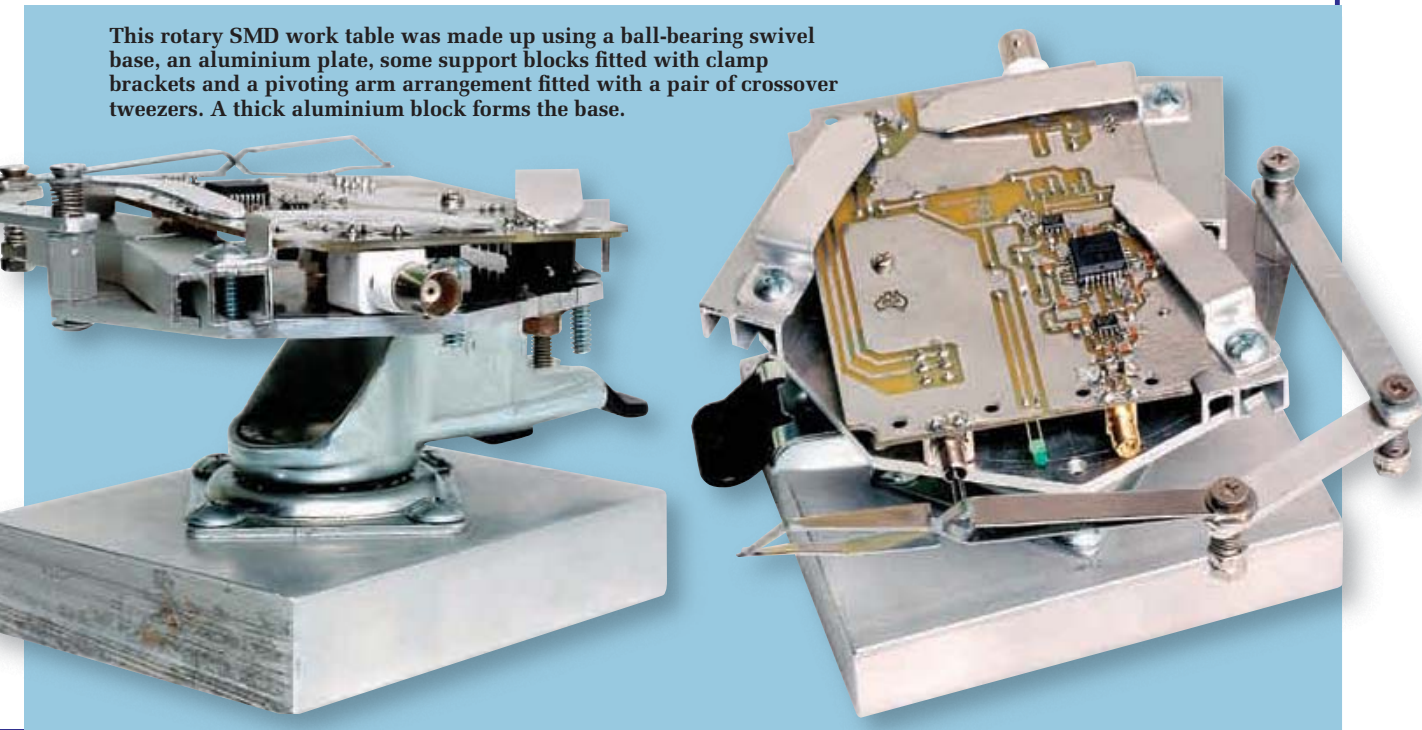

Fig.8: these two sequences show how to solder SOT, SOIC and PLCC devices into position. Note that it's important to use a soldering iron with a very fine tip for this job, to prevent shorts between pins.

This rotary SMD work table was made up using a ball-bearing swivel base, an aluminium plate, some support blocks fitted with clamp brackets and a pivoting arm arrangement fitted with a pair of crossover tweezers. A thick aluminium block forms the base.



# Constructional Project



The rear panel provides access to the two BNC output sockets and the DC power socket.

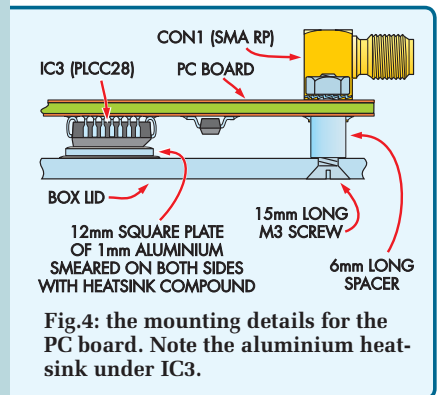

Fig.4: the mounting details for the PC board. Note the aluminium heat-sink under IC3.

of its frequency. So, if the camera or AV transmitter module is operating at say 2.432GHz, the counter will read 2.432MHz.

## Board mounting

If your Prescaler passes this quick checkout with no evident problems, you'll now be ready to assemble it in the box. This assumes that your box and its lid have been prepared, with the holes shown in the diagram of Fig.6 having been drilled. If the box hasn't been drilled yet, then now is the time to do so.

Note that the holes for the BNC connectors in the rear of the box are extended to form slots, so the box can be slipped down over the connectors.

As mentioned earlier, the PC board assembly is mounted on the lid on 6mm long untapped metal spacers. It's then secured using six M3 × 15mm countersink-head machine screws, as outlined below.

Before the board is fitted, attach the small 12mm × 12mm aluminium heatsink plate to IC3. This IC gets fairly warm in operation and the plate helps keep it cool by conducting heat away to the box lid – see Fig.4.

The plate is prepared by first thinly smearing it on both sides with heat-sink compound. That done, press one

## Functional checkout

At this stage your Prescaler should be electrically complete and ready for a quick functional checkout before it's fitted into the box. To check it out, place the PC board assembly on a clean timber or plastic surface and connect a 9V DC supply (eg, from a 9V 250mA plugpack or similar) to CON4. The positive input should connect to the centre pin of CON4.

Now turn on power switch S1 and you should see LED1 light up. This will confirm that LED1 is fitted with the correct polarity and also that REG1 is providing a +5V supply rail to the Prescaler's circuitry. To make sure that the supply voltage is correct, you can check it with a multimeter or DMM, connected between the centre and output pins of REG1.

You can also check the voltage across Zener diode ZD1, which should measure about 3.1V if the ECL circuit is working correctly.

## Self-oscillation

If all is well so far, try turning on your frequency counter and connecting its

input to one of the Prescaler's outputs (ie, CON2 or CON3). You may well find that the counter shows a reading straight away, even with no input signal applied to the Prescaler as yet. That's because IC2, the Prescaler's input divider, tends to self-oscillate when there is no input signal. So if you connect the second Prescaler output to a scope, you'll probably see a squarewave of about 1.6MHz.

There's no need to be concerned about this self-oscillation, because as soon as you feed in a 'real' UHF signal, it stops. The Prescaler's output changes immediately to a square-wave with a frequency 1/1000 that of the input signal.

If you have a source of UHF signals like a wireless CCTV camera or an AV transmitter module, try connecting its output to the Prescaler's input via a suitable SMA cable (note: you may need an SMA/RP SMA adaptor at one or both ends of the cable, depending on its own connectors). The counter should immediately begin reading its carrier frequency or strictly, 1/1000

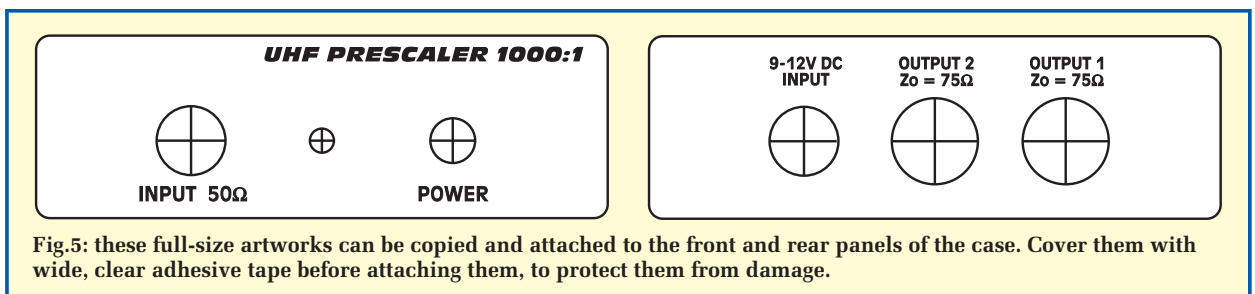

Fig.5: these full-size artworks can be copied and attached to the front and rear panels of the case. Cover them with wide, clear adhesive tape before attaching them, to protect them from damage.

side to the top of IC3's body, sliding it around a bit so any air bubbles are worked out. Then position it squarely over the IC body, where it will tend to stay put until you fit the board assembly to the box lid.

Attaching the board assembly to the lid is straightforward if you first fit the six countersink head screws through the lid holes and then turn the lid over and place it on the workbench. You then fit one of the 6mm spacers on each screw before lowering the inverted PC board assembly into position.

Be sure to press the board down gently just over the position for IC3 (see Fig.3), so that the heatsink compound on the lower surface of IC3's heatsink plate is partly transferred to the box lid underneath, to form a good thermal bond – see Fig.4.

After this, you can fit an M3 star lockwasher on the top of each board mounting screw, followed by an M3 nut. **It's then just a matter of carefully tightening each mounting screw and nut to secure the board and sandwich the aluminium heatsink in position.**

## Final assembly

The final assembly step is to fit the box over this assembly. To do this, first remove the nuts and lockwashers from BNC connectors CON2 and CON3 and also remove one nut, the keyed flat washer and the lockwasher from power switch S1. Thread the remaining nut right down to the switch body and then refit the keyed flat washer with its locating lug facing towards the switch body. This washer should also be down against the nut.

Now you should be able to bring the inverted box down over the PC board/lid assembly, at an angle so CON1, LED1 and switch S1 can be mated with the matching holes in the front end of the box. The box can then be lowered at the rear end and moved back at the same time, until the slots in its rear slip down around the threaded ferrules of CON2 and CON3. The box/cover will then be fully mated with the lid, allowing you to invert the whole 'shebang' and fit the four box assembly screws.

After this, all that remains is to fit the front and back panel dress stickers to the box (see Fig.5) and finally, refit the remaining nut to power switch S1 and the nuts to CON2 and CON3 at the back. Your UHF Prescaler should now be finished and ready for use.

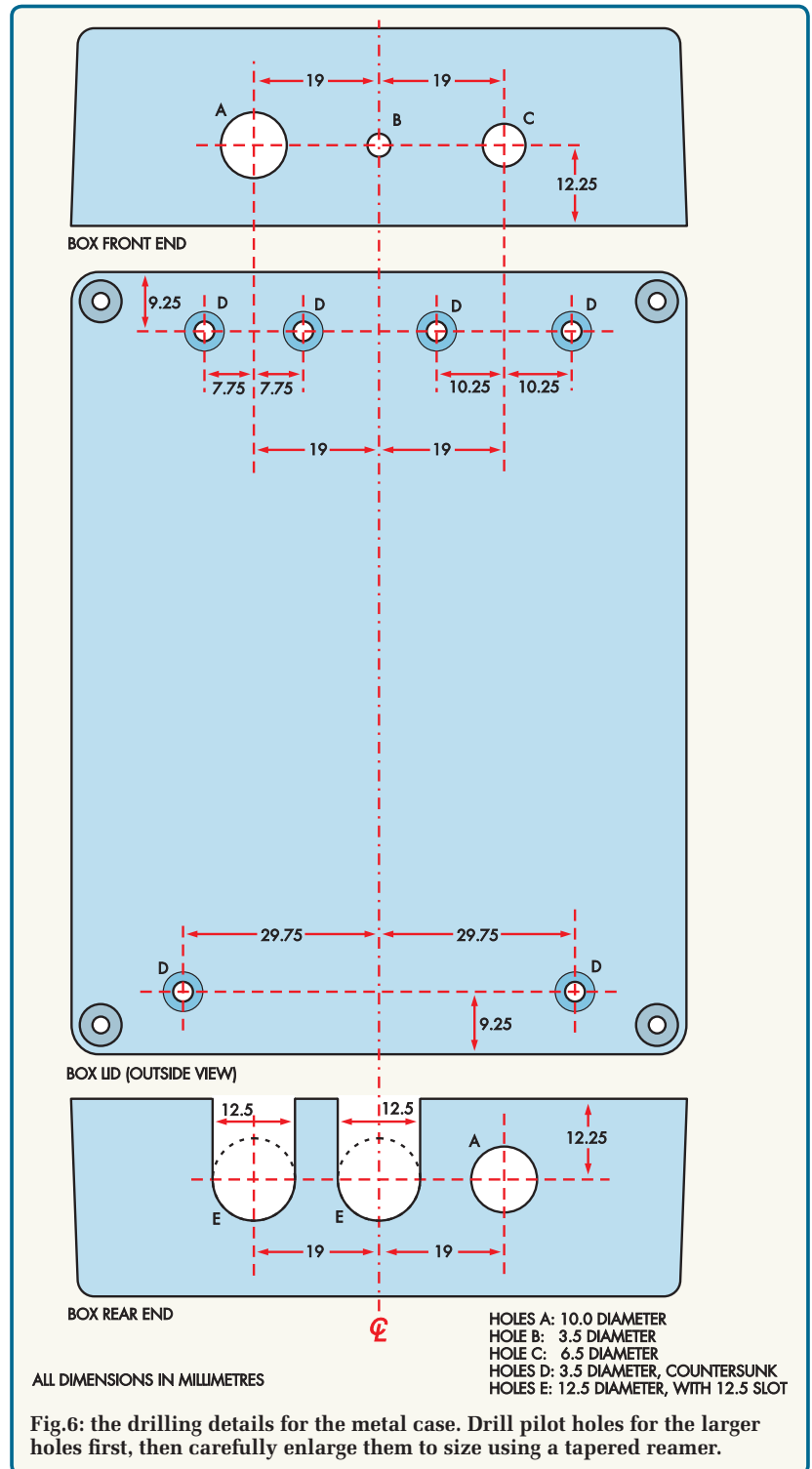

One final tip: when you're screwing SMA cable connectors and adaptors to the Prescaler's own input connector, be careful. These connectors are designed for precise mating, so

they can operate reliably, with low losses up to about 8GHz. As a result they're small and have a fine thread, making them easily damaged by rough treatment. **EPE**

# It's paper, but not as we know it

## TechnoTalk

Mark Nelson

**An accidental discovery by a British scientist could revolutionise the way we make everything from large-screen tellies to cars and aeroplanes. It may even explain how UFOs reach our planet intact – if of course they do. The name of the new wonder material is buckypaper and it's not a joke, as Mark Nelson assures us.**

Imagine an industrial material ten times lighter than steel, but 250 times stronger. Imagine that this substance is also a superb conductor of heat and electricity. What could you do with something like this?

### Deranged

You'd probably come up with ideas a lot more serious than the ultra-lightweight soldering irons that I just thought of. Although this material sounds like something out of a deranged science fiction novel, for designers in just about every field of engineering it is a dream come true. And it's not just a daydream; one American research group, the Florida Advanced Center for Composite Technologies (FAC2T), is already planning to develop real-world applications for just such a material.

The material's name is 'buckypaper', so called because it is made from buckminsterfullerene, an allotrope (variant) of carbon named after US architect, futurist and visionary Richard Buckminster Fuller (he's the guy who invented the geodesic dome structure). A sheet of buckypaper looks not unlike the carbon paper that people once used in typewriters to make multiple copies of a document, but its properties are totally different. As an Associated Press (AP) news report stated, 'Don't be fooled by its cute name or flimsy appearance; it could revolutionise the way everything from airplanes to TVs are made.' How so then, and what is buckypaper made of?

Buckypaper is one tenth the weight yet potentially 500 times stronger than steel when its sheets are stacked to form a composite. It disperses heat like brass or steel and it conducts electricity like metal or silicon. To quote Rice University scientist Wade Adams, "All those things are what a lot of people in nanotechnology have been working toward as a sort of Holy Grail."

### Meccano gets the credit

The buckminsterfullerene that buckypaper is made of is based on carbon nanotubes – amazingly strong fibres of carbon that individually measure about one 50,000th of the diameter of a human hair. The remarkable strength comes from the specific type of carbon molecule used, carbon 60. The powerful atomic bonds within the molecule make this material twice as hard as a diamond.

Carbon 60, alias buckminsterfullerene, was first developed two decades ago by British born and raised Sir Harold Kroto.

He was part of a team intent on discovering how stars, the source of all carbon in the universe, actually created the element that is a main building block of life on Earth. A totally unexpected discovery was a carbon molecule formed of 60 atoms shaped like a football. It reminded Kroto of the geodesic domes that Buckminster Fuller had patented. Interestingly, he was captivated as a child by his Meccano set and he credits this, amongst other things, with developing skills useful in scientific research.

Working first at the University of Sussex, he is now a professor at Florida State University. Together with two other scientists, he shared the 1996 Nobel Prize in Chemistry for their discovery of Buckminsterfullerene, nicknamed 'buckyballs' after the spherical shape of the molecules. Their discovery revolutionised chemistry and materials science, contributing directly to the development of buckypaper.

### Applications a-plenty

What could we make with buckypaper then? The man with the answers is Ben Wang, a professor of industrial engineering at the FAC2T research group, which incidentally has grabbed the web domain **Buckypaper.com**. He lists the following potential uses under research currently:

- If exposed to an electric charge, buckypaper could be used to illuminate computer and television screens. It would be more energy-efficient, lighter, and would allow for a more uniform level of brightness than current cathode ray tube (CRT) and liquid crystal display (LCD) technology.

- As one of the most thermally conductive materials known, buckypaper lends itself to the development of heatsinks that would allow computers and other electronic equipment to disperse heat more efficiently than is currently possible. This, in turn, could lead to even greater advances in electronic miniaturisation.

- Because it has an unusually high current-carrying capacity, a film made from buckypaper could be applied to the exteriors of aeroplanes. Lightning strikes would flow around the plane and dissipate without causing damage.

- Films also could protect electronic circuits and devices within aeroplanes from electromagnetic interference, which can damage equipment and alter settings. Similarly, such films could turn military aircraft into 'stealth planes' by shielding their electromagnetic 'signatures', which are used for radar recognition.

There are of course many challenges facing the scientists before these ideas turn into commercial reality. A crucial problem is the high cost of the process that makes nanotubes and then forming them, along with binder materials, into buckypaper, which is a thin film. The AP report explains that left to their own devices, the carbon tubes 'clump together at odd angles', which limits the strength of the buckypaper.

However, Wang and his fellow researchers have discovered a remedy, exposing the tubes to an intense magnetic field. This makes most of them line up in the same direction, increasing their collective strength. He asserts, "Our plan is perhaps in the next 12 months we'll begin maybe to have some commercial products. Nanotubes obviously are no longer just lab wonders. They have real world potential. It's real."

### The UFO connection and vacuum tubes

Up to now, one of the most compelling 'killer' arguments used to decry visits to earth from other universes is that the little green men's spacecraft would be crushed and destroyed by inter-space pressures. But if these aliens have more highly developed technologies than we do, then buckypaper-like materials might well provide the means of making spacecraft that could endure those conditions. Already this notion is being debated in online forums with comments such as "I can already see entire spacecraft made of this stuff further reducing launch costs as well as super-strong body armour and who knows what other applications this stuff will have."

Carbon nanotubes already have some real-world applications; they are, for instance, being used to strengthen tennis rackets and bicycle frames, but in small amounts only. Reasons for that include the high cost of manufacturing them and the fact that the tubes are so perfectly smooth, making it difficult to 'glue' them together. In fact, researchers are examining ways of making them rougher to give the epoxy adhesive used a means of bonding better.

Incidentally, if carbon nanotube applications in electronics ring a faint bell, your memory is not playing tricks. Back in the 1990s, carbon nanotubes were heralded as the facilitator for a new generation of vacuum tubes (or valves, to me and you). In a number of experiments, carbon nanotubes were used as electron field emitters in triode-type valves and fluorescent lamp tubes. The technique promised dramatically higher efficiency, reduced electron scatter, faster turn-on times and the possibility of making more robust and compact devices. Little has been heard since, however.

# USB Connectivity for Embedded Designs

Microcontrollers

Digital Signal  
Controllers

Analog

Serial  
EEPROMs



If you need Full-Speed USB 2.0 device, embedded host, dual role and On-The-Go solutions, Microchip Technology has them available today. We offer 8-, 16- and 32-bit MCUs with USB connectivity, providing easy migration with a single development environment. This maximizes pin compatibility and seamless code migration from 20 to 100 pins, enabling you to scale your USB design with ease.

## Download FREE USB software including source code:

- Host Stack
- OTG Stack
- Device Stack
- Class Drivers (HID, Mass Storage and CDC Drivers)
- Thumb Drive Support (Mass Storage Driver, SCSI Interface, 16-bit and 32-bit File Management, Application Software)

Core	Flash Program Memory	Pins	USB Type
8-bit	Up to 128 Kbytes	20 - 80	Device
16-bit	Up to 256 Kbytes	64 - 100	Device, Embedded Host, Dual Role, OTG
32-bit	Up to 512 Kbytes	64 - 100	Device, Embedded Host, Dual Role, OTG

## GET STARTED IN 3 EASY STEPS

1. Purchase a USB Starter Kit
2. Download Free USB Software
3. Order Free Samples

[www.microchip.com/usb](http://www.microchip.com/usb)

USB Starter Kits accelerate development of USB designs using 8-, 16- or 32-bit MCUs and are available at [www.microchipDIRECT.com](http://www.microchipDIRECT.com) or from one of our authorised distributors



## Intelligent Electronics start with Microchip

**microchip**  
**DIRECT**  
[www.microchipdirect.com](http://www.microchipdirect.com)

[www.microchip.com/usb](http://www.microchip.com/usb)

**MICROCHIP**

The Microchip name and logo, the Microchip logo, dsPIC, MPLAB and PIC are registered trademarks of Microchip Technology Incorporated in the U.S.A. and other countries. All other trademarks mentioned herein are property of their respective companies. © 2008, Microchip Technology Incorporated. All Rights Reserved. ME204Eng/05.08



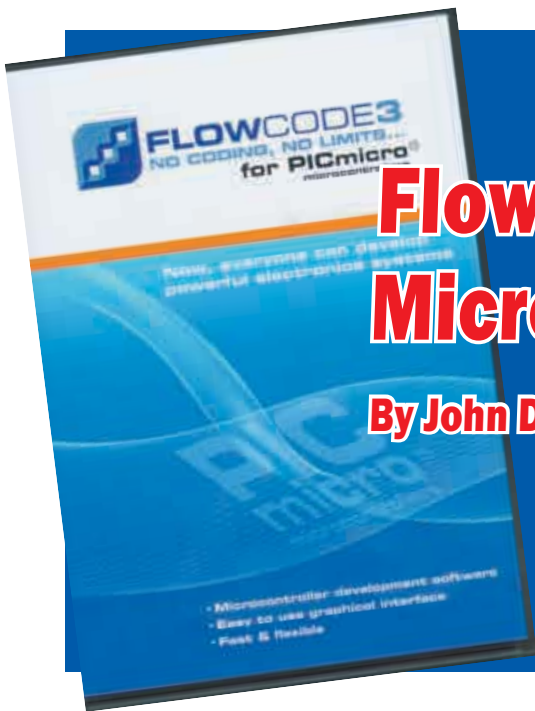

# Flowcode And The Microchip PICkit 2

By John Dobson



## Using Flowcode to programme PICs with the PICkit 2

**M**ICROCHIP'S PICkit 2 Debug Express with the 44-pin Demo Board, reviewed in the June 2007 edition of *EPE*, must be in line for a prize as the world's smallest PIC programmer.

Equally impressive is Matrix Multimedia's Flowcode programming language, which allows you to dispense with MPLAB IDE and provides you with an intuitive flowchart programming interface.

This article offers an introduction to programming PIC microcontrollers using the free version of Flowcode (limited to 2K of compiled code), and shows you how to use it to create a simple LED flashing program for the PICkit 2 44-pin Demo Board. This should allow you to get to grips with the basic operation of Flowcode and PICkit 2.

### Flowchart

Program design often starts with a flowchart, planning the sequence of steps which the microprocessor will follow. With Flowcode, it is a very simple matter to convert the flowchart into a Flowcode program.

This first example develops a system which outputs one of two lighting patterns, depending on whether or not a switch is pressed. You can see this in Fig.1 (opposite).

Let's now convert this into a Flowcode program.

A free demo version of Flowcode is available from: <http://www.matrixmultimedia.com/temp/FlowcodeV3.exe>. The complete software is available from *EPE*. It is also available as part of a *Special Package Offer* bundled with TINA Pro V7 (Basic), the circuit simulation, testing and PCB design software – see the *CD-ROMs For Electronics* pages in this issue.

When you install Flowcode, make sure that the 'Microchip PICkit 2' option is selected.

- Run the Flowcode application.
- Click on the 'OK' button when the reminder screen opens.
- Next, you have the option of creating a new Flowcode flowchart, or opening an existing one. Select the option to create a new one.

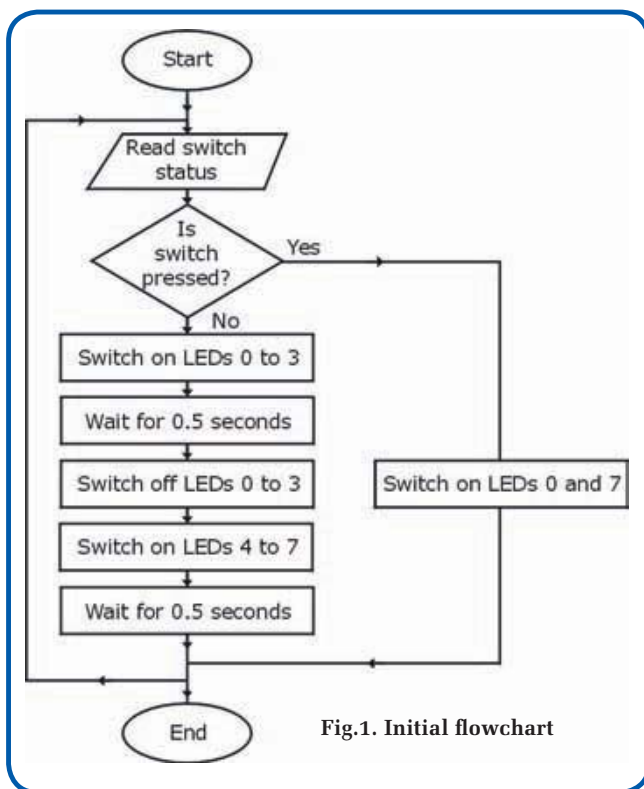

Fig.1. Initial flowchart

- You now have to choose a target PIC microcontroller. The 44-pin Demo Board is fitted with a PIC16F887, so choose that from the list.
- A new workspace called 'Main' opens.
- Click and drag icons from the Icons Toolbar running down the left-hand edge of the screen, to make the Flowcode flowchart shown in Fig.2. For the moment, do not worry about configuring them – we will do that next.

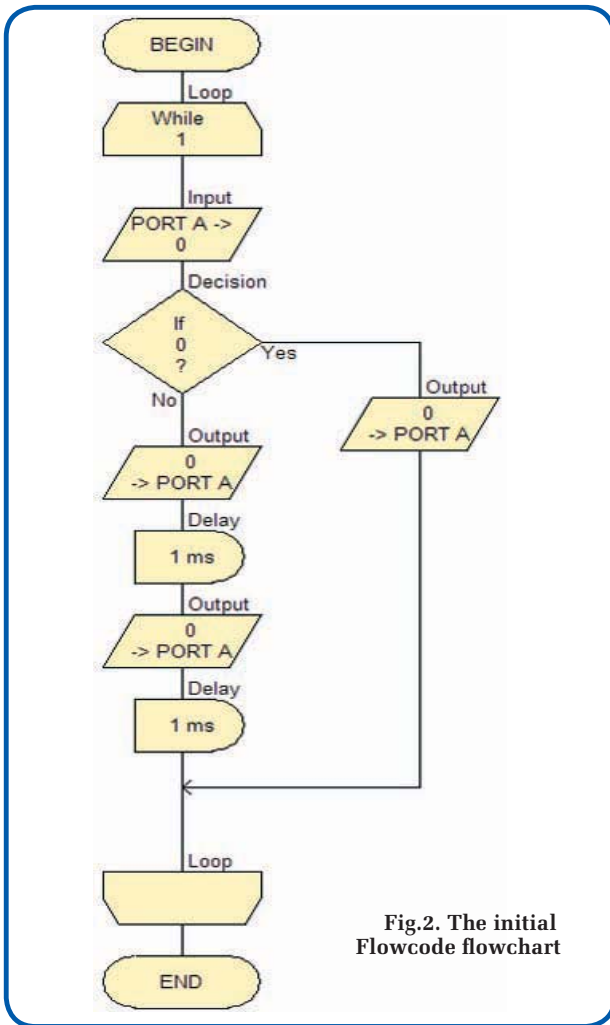
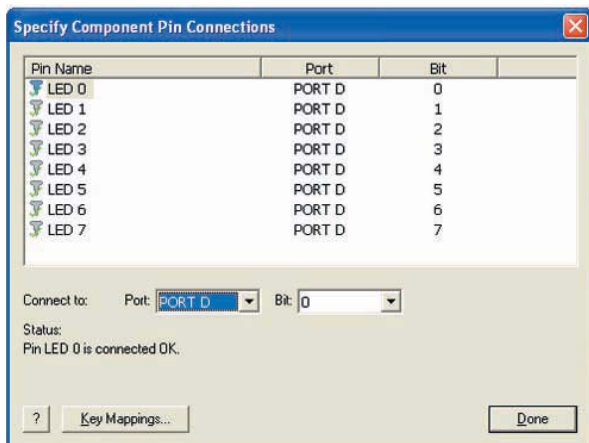

Fig.2. The initial Flowcode flowchart

● Now add the hardware. Click on the LED icon in the Components Toolbar, running just inside the Icon Toolbar. Also click on the switch icon. You now have two more items on the workspace.

● Select the LED component in the workspace, click on the drop-down menu button and select the 'Component Connections' option. In the 'Connect to Port' drop-down menu, select Port D, (because the LEDs on the 44-pin Demo Board are connected to Port D.) The Connections dialogue box should now look like the following:



● Next, select the Switch component in the workspace. Click on the drop-down menu button, select the 'Properties' option, and set the number of switches to one.

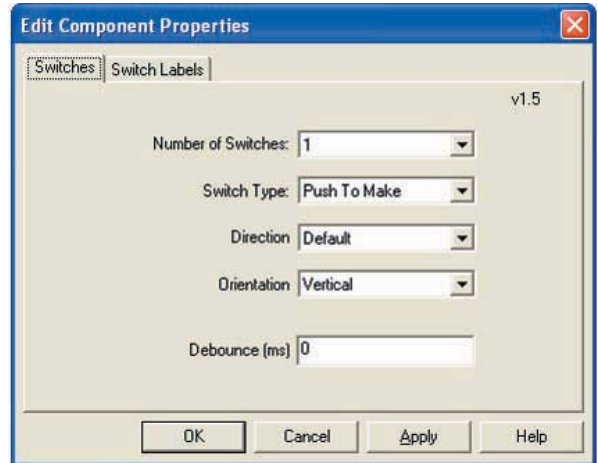

In the 'Connect to Port' drop-down menu, select Port B, (because the pushswitch on the 44-pin Demo Board is wired to bit 0 of Port B.) The Connections dialogue box should now resemble the following:

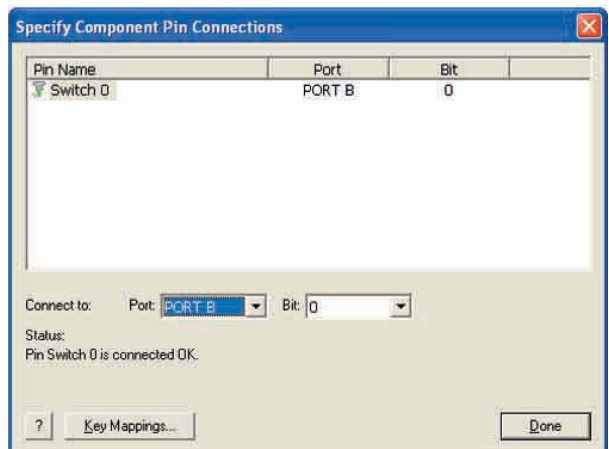

## Configuring the icons

Now it is time to configure the icons that make up the Flowcode flowchart. To do this, double-click on each icon in turn and set up the configurations shown in the following diagrams. In the 'Display name' boxes, type the text from the corresponding element of the flowchart. This makes it easier to check your progress.

## The Loop icon

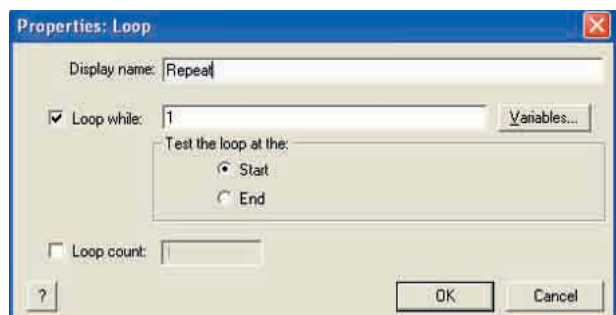

## The Input icon

First of all you need to create a variable to carry the switch information. Click on the 'Variables...' button to open the 'Variable Manager' window. Click on the 'Add New Variable' button, and type 'Input' as the name of the new variable, as shown in the next screenshot.

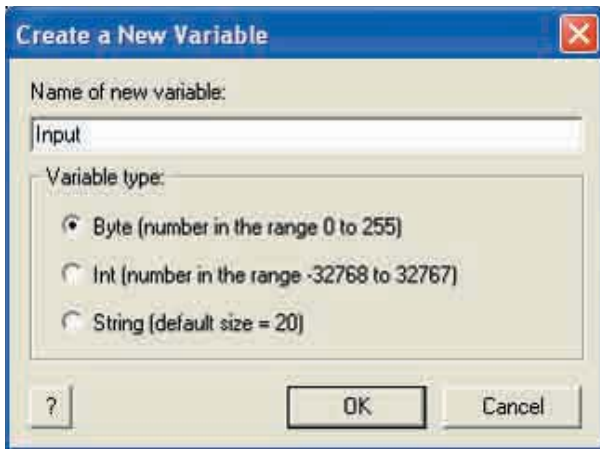

Then click 'OK'. Back in the Variable Manager window, click on 'Use Variable'. Back in the Input Properties window, select Port B, and 'Single Bit', so that the dialogue box now looks like:

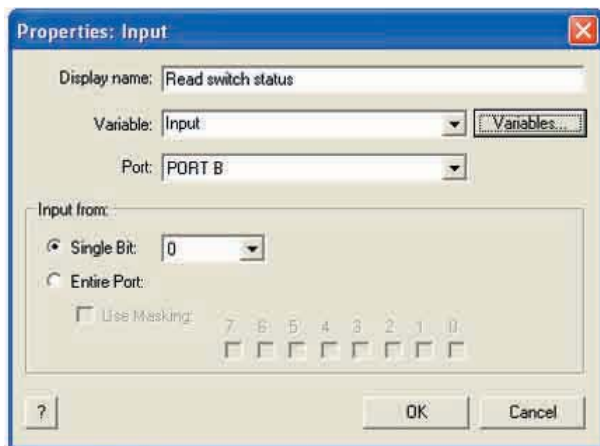

## The Decision icon

In the Properties dialogue box, click on the 'Variables' button and select the 'Input' variable for use. Type 'Is switch pressed' in the 'Display name' box. You should now have:

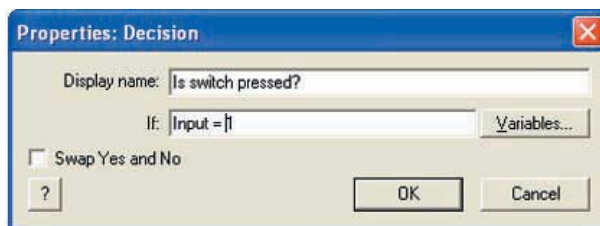

## 'No' Loop: The Output icon

LED 7 is the most significant bit of the display, and so has a place value of 128 ( $= 2^7$ ).

LED 0 has a place value of 1 ( $= 2^0$ ). To make both light, you output a value of 129 to Port D, where the LEDs are connected.

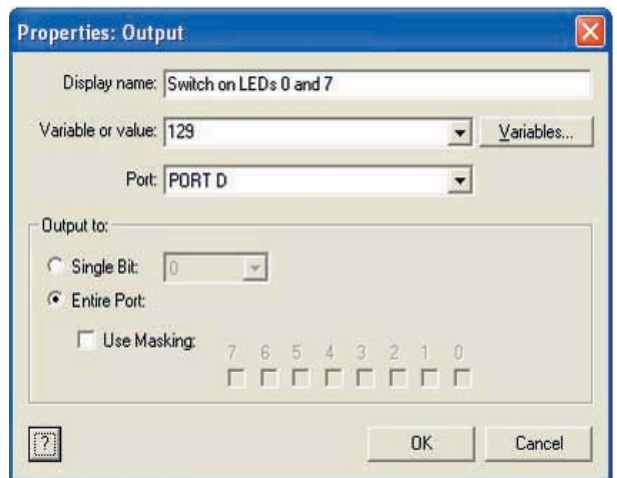

## 'Yes' Loop: First Output icon

The first four LEDs, 0 to 3, have place values of 1, 2, 4 and 8 ( $= 2^0, 2^1, 2^2$  and  $2^3$  respectively). You can light all four by outputting a value of 15 ( $= 1 + 2 + 4 + 8$ ) to Port D, as shown in the next screenshot.

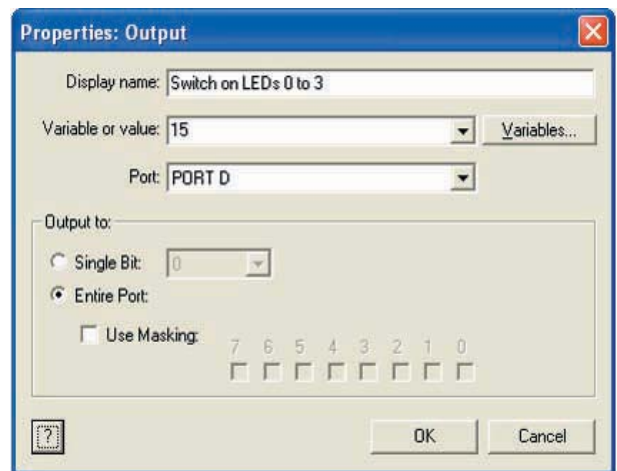

## Both Delay icons

The duration of the delay can be specified either in milliseconds or seconds. To create a half-second display, type 500 as the 'Delay value', with the 'milliseconds' button selected, since 500ms = 0.5s.

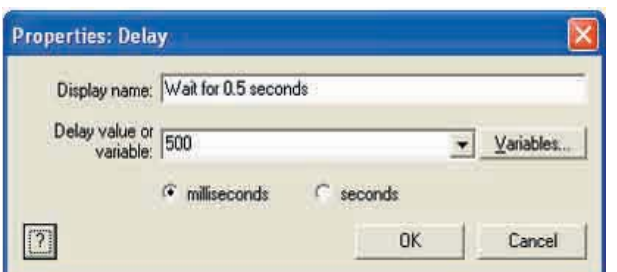

## Second Output icon

The LEDs 4 to 7 have place values of 16, 32, 64 and 128 ( $= 2^4, 2^5, 2^6$  and  $2^7$  respectively). To light all four, output a value of 240 ( $= 16 + 32 + 64 + 128$ ) to Port D, as shown in the next screenshot.

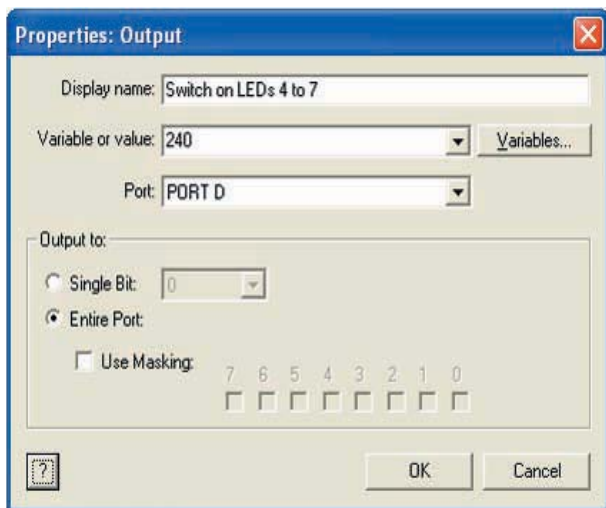

Now your Flowcode flowchart should look like Fig.3.

## Simulate the program

Flowcode allows you to check whether your program works by running an on-screen simulation. This can be done in two ways, simulating the full program, or stepping through the simulation, icon by icon. In both cases, two windows, the 'Variables' window, and the 'Call Stack' window, appear while the simulation runs. When you run the program simulation at full speed, the values in these windows are not updated as the program runs. If you slow down the full program simulation, or if you step through the program, then you will see the effect of each stage on the variables you created, shown in the 'Variables' window.

For now, look at the full simulation running at full speed. Click on the 'Run' command in the Menu toolbar. Choose the 'Go/Continue' option. The 'Variables' window, and the 'Call Stack' window appear, and LEDs 0 and 7 light. Click on the pushswitch icon, and the LEDs should flash on and off, with LEDs 0 to 3 alternating with LEDs 4 to 7. The program works!

(If it does not, then go back and check the configuration details given above. You could simulate the program step-by-step, by clicking on the 'Step Into' option in the 'Run' menu, and then using the F8 key to move to the next step.)

## Programming the PIC microcontroller

The groundwork is done – you have a working Flowcode program. The rest is easy! Here are instructions for getting your program into the chip:

- Connect the PICKIT 2 module to your computer using the USB cable.
- Plug the 44-pin Demo Board into PICKIT 2.
- Click on the 'Chip' command in the Menu toolbar, and select the 'Compile to Chip...' option. (You may be asked to save the Flowcode program – click on the 'Yes' button.)
- A 'Compiler Messages' window opens to show progress, as various elements are launched. The Target and Busy LEDs on PICKIT 2 light when the program is transferred. Finally, the 'Compiler Messages' window shows the word 'FINISHED', at which point you can click on the 'Close' button.
- Your program should now be running on the 44-pin Demo Board. LEDs 0 to 3 and 4 to 7 are alternately on then off. Press the pushswitch, and the LED pattern should change, with only LEDs 0 and 7 lit. That's what your Flowcode program said!
- Unseen by the user, the Flowcode programmer first compiled the graphical flowchart to a C file, and then compiled that to assembler. These can be viewed by C and assembler buffers either by using the 'View C' and 'View ASM' commands under the 'Chip' command on the Menu toolbar, or by opening the files *prog1name.c* and *prog1name.asm* in the folder where you saved the Flowcode program (where *prog1name* is the name you gave to that program.)

## Finally!

Although this article has shown in some detail how to build and configure Flowcode flowcharts, much of the functionality of Flowcode has not been mentioned. The ability to perform calculations, manipulate string variables, create customised macros and inject sections of C programming has not been mentioned, along with a host of other powerful features of the program.

Fortunately, the program comes equipped with a set of tutorials, accessed via the Help menu. Matrix Multimedia also offers a variety of supporting resources, available via their website [www.matrixmultimedia.com](http://www.matrixmultimedia.com). *EPE*

## Special offer

To start designing your new project, see the extra special offer from Microchip and *EPE* on the next page!

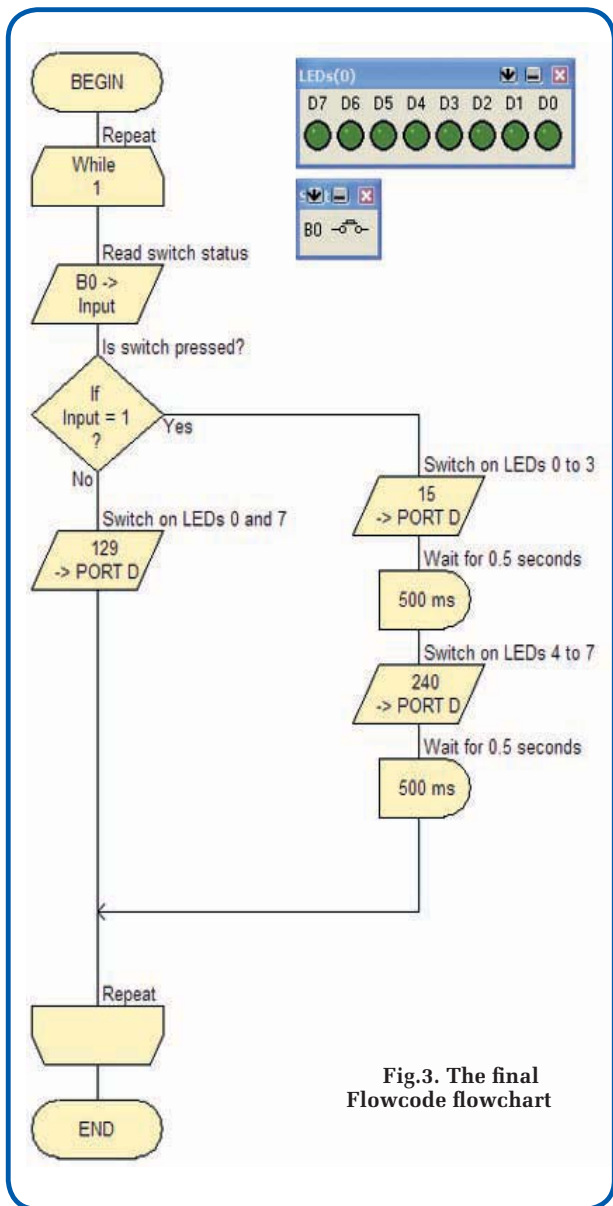

Fig.3. The final Flowcode flowchart

# A VERY SPECIAL OFFER TO EPE READERS!

## Your chance to buy a Microchip PICkit™ 2 Debug Express Kit

only  
**£9.99**

Everyday Practical Electronics and Microchip have teamed up to offer you the chance to buy a PICkit™ 2 Debug Express Kit (DV164121) at an unprecedented discount price! In this issue of EPE, you have the chance to purchase this kit via microchipDIRECT at an unmissable price of only £9.99 - including VAT and Delivery to UK addresses! As this is an unprecedented price the offer is limited to one per household, (UK addresses only) / one per e-mail address.



PICkit™ 2 is a pocket sized complete programmer and debugger which allows easy in-circuit development of selected PIC® microcontrollers. Any personal computer can become a development station using the supplied MPLAB® IDE development tool for writing code, debugging and programming devices. A single USB port is used to interface with the PICkit 2 and control your PIC project, enabling you to halt, single step and break point your code on your target board.

The Kit includes Microchip's 44-pin PIC16F887 Flash microcontroller demo board, the PICkit 2 programmer, USB cable and software CDs, including Microchip's MPLAB IDE integrated development environment, CCS PCM™ Midrange C Compiler Demo for PIC16F887 and HI-TECH PICC™ LITE C Compiler - enabling new users to easily get started with an embedded control design.

### How to buy your PICkit 2 Debug Express Kit at this special price:

- Go to <http://microchipdirect.com>, Register or log on to the site with the Great Britain - Union Jack flag and enter the part number DV164121.
- Add the PICkit to the Shopping Cart and then enter the Coupon number - EPEPIC08 and press the apply coupon button.
- Select checkout which will take you to the address and payment processes - remember to accept the terms & conditions and then place the order.
- Allow up to 28 days for delivery.

Conditions: This offer is only valid to UK readers - Only one PICkit™ 2 Debug Express Kit per household and or one per e-mail address is allowed. This offer applies to all UK purchases made before 31st January 2009 via microchipDIRECT and inserting and quoting the correct coupon reference. This offer may not be used in conjunction with any other offer. This coupon has no cash value. This offer may be withdrawn without prior notice. The coupon must be used in conjunction with all other terms and conditions specified by Microchip Technology Inc.

**microchip**  
**DIRECT**  
[www.microchipdirect.com](http://www.microchipdirect.com)

 **MICROCHIP**  
[www.microchip.com](http://www.microchip.com)

The Microchip name, logo, PIC and MPLAB are registered trademarks of Microchip Technology Incorporated in the USA and other countries. All other trademarks and registered trademarks are the property of their respective owners, © Microchip Technology Inc. All rights reserved ME216/Eng/09.08

# EPE PIC RESOURCES CD-ROM V2

Version 2 includes the EPE PIC Tutorial V2 series of Supplements (EPE April, May, June 2003)

The CD-ROM contains the following Tutorial-related software and texts:

- EPE PIC Tutorial V2 complete series of articles plus demonstration software, John Becker, April, May, June '03
- PIC Toolkit Mk3 (TK3 hardware construction details), John Becker, Oct '01
- PIC Toolkit TK3 for Windows (software details), John Becker, Nov '01

Plus these useful texts to help you get the most out of your PIC programming:

- How to Use Intelligent LCDs, Julyan Ilett, Feb/Mar '97
- PIC16F87x Microcontrollers (Review), John Becker, April '99
- PIC16F87x Mini Tutorial, John Becker, Oct '99
- Using PICs and Keypads, John Becker, Jan '01
- How to Use Graphics LCDs with PICs, John Becker, Feb '01
- PIC16F87x Extended Memory (how to use it), John Becker, June '01
- PIC to Printer Interfacing (dot-matrix), John Becker, July '01
- PIC Magick Musick (use of 40kHz transducers), John Becker, Jan '02
- Programming PIC Interrupts, Malcolm Wiles, Mar/Apr '02
- Using the PIC's PCLATH Command, John Waller, July '02
- EPE StyloPIC (precision tuning musical notes), John Becker, July '02
- Using Square Roots with PICs, Peter Hemsley, Aug '02
- Using TK3 with Windows XP and 2000, Mark Jones, Oct '02
- PIC Macros and Computed GOTOs, Malcolm Wiles, Jan '03
- Asynchronous Serial Communications (RS-232), John Waller, unpublished
- Using I2C Facilities in the PIC16F877, John Waller, unpublished
- Using Serial EEPROMs, Gary Moulton, unpublished
- Additional text for EPE PIC Tutorial V2, John Becker, unpublished

NOTE: The PDF files on this CD-ROM are suitable to use on any PC with a CD-ROM drive. They require Adobe Acrobat Reader – included on the CD-ROM



**ONLY £14.45**  
INCLUDING VAT and P&P

## EPE PIC RESOURCES V2 CD-ROM ORDER FORM

Please send me ..... (quantity)

### EPE PIC RESOURCES V2 CD-ROM

Price £14.45 each – includes postage to anywhere in the world.

Name .....

Address .....

.....

.....

..... Post Code .....

I enclose cheque/PO./bank draft to the value of £ .....

please charge my Visa/Mastercard/Maestro £ .....

Card No. ....

Card Security Code .....  
(The last 3 digits on or just under the signature strip)

Valid From ..... Expiry Date .....

Maestro Issue No. ....



SEND TO:

**Everyday Practical Electronics,  
Wimborne Publishing Ltd.,  
Sequoia House, 398a Ringwood Road, Ferndown,  
Dorset BH22 9AU.**

Tel: 01202 873872. Fax: 01202 874562.

Email: [orders@epemag.wimborne.co.uk](mailto:orders@epemag.wimborne.co.uk)

Payments must be by card or in £ Sterling – cheque or bank draft drawn on a UK bank.

Normally supplied within seven days of receipt of order.  
Send a copy of this form, or order by letter if you do not wish to cut your issue.

Order on-line from  
[www.epemag.com](http://www.epemag.com)  
or by Phone, Fax, Email or Post.

## BECOME A PIC WIZARD WITH THE HELP OF EPE!

# Stereo Class-A Amplifier Pt.4

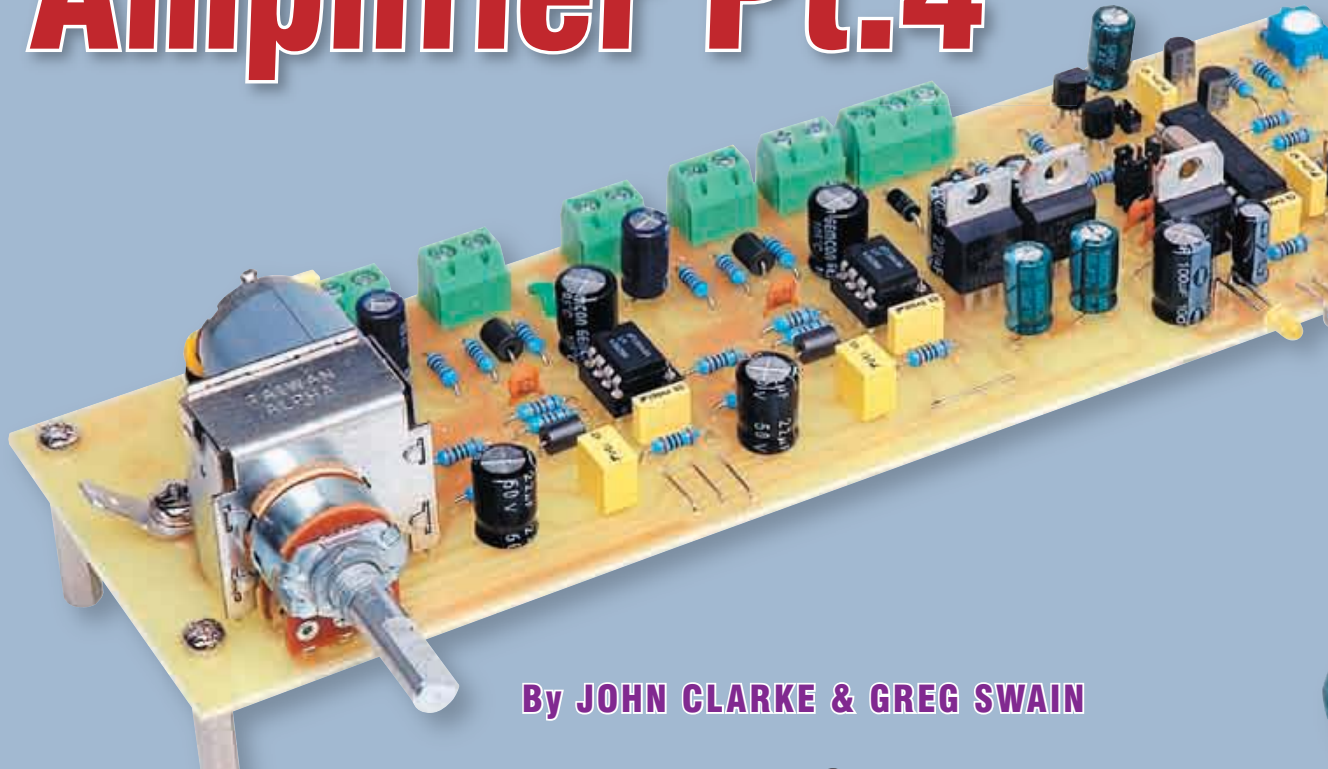

By **JOHN CLARKE & GREG SWAIN**

## Preamplifier & Remote Volume Control Module

**In Part 4 this month, we present a high-performance Stereo Preamplifier & Remote Volume Control module. It's a low-noise, low-distortion design, specifically engineered for the Class-A amplifier, but it can also be used with other stereo power amplifiers.**

**D**EPENDING on your requirements, you have several options when it comes to using the new Class-A Stereo Amplifier. Basically, the unit can be combined with a high-quality external preamplifier or used as a stand-alone unit.

Typically, an external preamplifier will be necessary if you want to connect several signal sources and switch

between them; eg, select between a CD player, DVD player and a tuner. The Class-A Stereo Amplifier would then function simply as a power amplifier, with the signal from the external preamp fed directly to the inputs of the power amplifier modules. In this case, all you would need to build into the chassis are the left and right-channel Class-A Power Amplifier modules (Oct'08 and

Nov'08), plus the Loudspeaker Protector & Muting Module (Dec'08).

If you do elect to use an external preamplifier, then the Studio Series Stereo Preamplifier (Feb'08) makes the ideal companion unit. The Studio Preamplifier is an excellent performer that's quite up to the job (especially considering its distortion is typically less than 0.0005%).

## Preamplifier features and performance

### Main features

- High performance design – very low noise and distortion
- Designed for the Class-A Stereo Amplifier, (Oct, Nov'08) but can also be used with other power amplifier modules
- On-board remote volume control circuit with motorised potentiometer and muting

### Measured performance

Frequency response.....	flat from 10Hz to 20kHz, -3dB @ 100kHz
Input impedance .....	~22k $\Omega$
Output impedance.....	100 $\Omega$
Harmonic distortion.....	typically <0.0005%
Signal-to-noise ratio.....	-125dB unweighted for 1V input
Channel crosstalk.....	typically -125dB

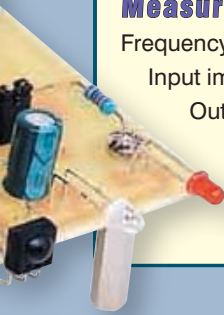

### Volume control

Alternatively, many readers will want to use only one signal source, typically a CD or DVD player. In that case, the Class-A Stereo Amplifier can be used as a standalone unit, but you do need to add a volume control. If your CD player is already fitted with an output level control, you may be tempted to dispense with a volume control on the amplifier, but that could be a mistake.

Just imagine what a blast you will get from the amplifier and loudspeakers if you turn on the CD player and it has been inadvertently set to full output level. The result would not only be deafening, but it could easily blow your tweeters.

The simplest solution that we would recommend is to feed the signal in via a dual-ganged (stereo) 10k $\Omega$  *log* pot and we'll show you how to do that next month, when we bring all the modules together into a single unit, if you want to use that option. This simple scheme does have its problems though. First, the input signal level may be insufficient to drive the amplifiers to full power output, even when using a CD player. The amplifier modules have an input sensitivity of 625mV for full power, but some recordings may give average output signal levels well below this.

Second, using a simple volume control varies the input impedance to the power amplifiers, thereby slightly degrading the signal-to-noise ratio. Admittedly, we're splitting hairs somewhat here – but after all, this is a true audiophile's amplifier.

### Preamplifier module

So how do you eliminate those problems and achieve the level of performance we want? The answer is to incorporate a high-quality preamplifier module into the Class-A Stereo Amplifier chassis. This will result in an attractive self-contained package that we think will appeal to many people – particularly those who just want to use a single CD/DVD player.

The preamplifier module described here meets the above criteria. It's a minimalist design, which delivers ultra-low noise and distortion, but with more than enough gain (with the 'wick' wound right up) to drive the 20W Class-A

Amplifier modules to full power output. In fact, if you were to wind it up too far, the amplifier will be driven well into clipping and horrible distortion.

That pretty much defeats the purpose of building a high quality amplifier, so don't do it!

This preamplifier is a two-chip design, employing a dual op amp IC in each channel, the first stage providing the gain and the second stage acting as a buffer for the volume control, to present a constant low output impedance to the power amplifier modules.

### Low-noise op amps

The original Studio Series Preamplifier mentioned earlier was based on the high-performance OPA2134 op amps from Burr-Brown. These are specified at an extremely low 0.00008% harmonic distortion at 1kHz and the harmonic distortion (THD) for the completed preamplifier was typically less than 0.0005%.

This time we've gone one better and specified the National Semiconductor LM4562 dual op amp. This fairly new device is specified at just 0.00003% harmonic distortion at 1kHz, which is even lower than for the OPA2134. In fact, it is far below the measurement capability of most commercially available test equipment.

As a result, the performance of the module on its own is actually far better than the completed stereo amplifier. Just running with its own regulated supplies (and not connected to the amplifier), the preamplifier module delivers a harmonic distortion figure that's typically less than 0.0005%. Furthermore, its signal-to-noise ratio with respect to a 1V input signal is around -125dB unweighted (22Hz to 22kHz bandwidth) and separation between channels is also around -125dB.

Ultimately, it is not possible to get this fantastic performance from the completed stereo amplifier. And why not? The main reason is that residual noise and hum from the power supply degrades the overall measured result, even though the finished amplifier is extremely quiet.

Would it be possible to get a better measured distortion performance? The answer is a qualified yes, provided we had completely separate power supplies for both channels. The same comment applies to channel separation and residual noise. Such a solution would be a lot more expensive and would probably



# Constructional Project

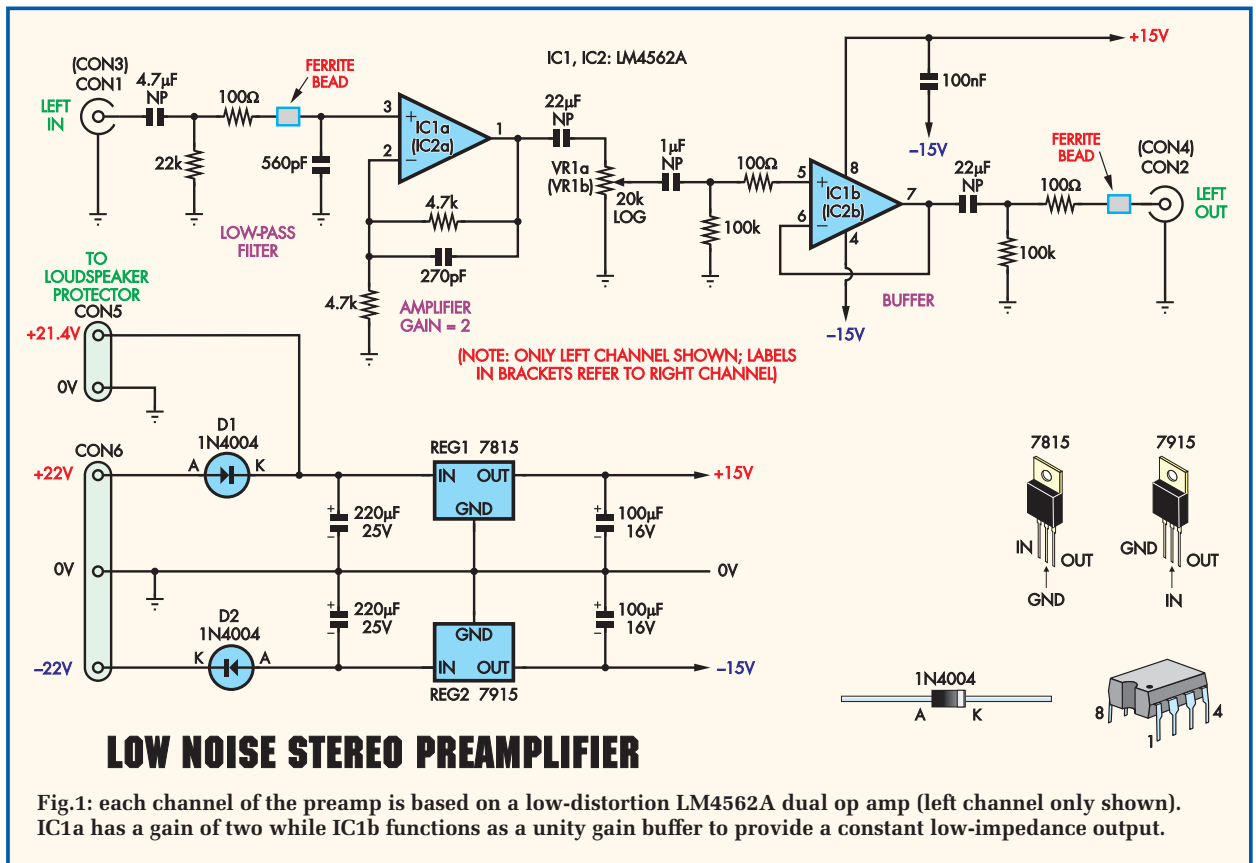

involve two separate power amplifiers – the so-called ‘mono block’ solution.

By the way, there’s no source selection built into the preamplifier, as we’re assuming that you will be using it with just a single source. If you do want to switch between different sources, then you will need to use an external switch box (or an external preamp, as indicated earlier).

## Remote volume control

OK, we just couldn’t help ourselves – we just had to include remote volume control as part of the preamp design. After all, no sound system is complete these days without remote volume control and this one has all the ‘must-have’ features.

By using the recently-released PIC16F88-I/P chip, as opposed to the

PIC16F84 used in an earlier design, we’ve been able to eliminate an LM393 comparator IC and a low-voltage reset circuit.

The remote Volume Control section uses a motorised potentiometer. Press the ‘Volume Up’ and ‘Volume Down’ buttons on your remote control and the pot rotates clockwise and anticlockwise. It takes about nine seconds for the pot to travel from one end to the other using these controls.

For finer adjustment, the ‘Channel Up’ and ‘Channel Down’ buttons can be used instead. These cause the pot shaft to rotate only about 1° each time one of these buttons is pressed. Alternatively, holding one of these buttons down rotates the pot from one end to the other in about 28 seconds.

If any button is held down when the pot reaches an end stop, a friction clutch in the motor’s gearbox slips so that no damage is done.

Automatic muting is another handy feature. Press the ‘Mute’ button on the remote and the pot automatically rotates to its minimum position and the motor stops. Hit the button again and it returns to its original position. Don’t want the pot to return all the way to its original setting? Easy – just hit one of the volume control buttons when the volume reaches the desired level.

A couple of LED indicators – ‘Ack’ and ‘Mute’ – are used to indicate the status of the Remote Volume Control. The blue Ack (acknowledge) LED flashes whenever an infrared signal is being received from the remote, while the orange Mute LED flashes while the muting operation is in progress and then remains on when the pot reaches its minimum setting.

So how does the unit remember its original setting during muting? Well, the microcontroller actually measures the time it takes the pot to reach its minimum setting. Then, when the Mute button is pressed again to restore the

## Altronics has the complete kit

A complete kit of parts for the 20W Class-A Stereo Amplifier is available from Altronics, Australia. This kit comes with all the necessary parts, including a pre-punched custom metal chassis and front and rear panels with screened lettering. They sell the various modules separately, for those who don’t need the complete amplifier. Browse: [www.altronics.com.au](http://www.altronics.com.au) for the details.

volume, power is applied to the motor drive for the same amount of time.

## Preamplifier circuit details

OK, so much for the background stuff. Let's see how it all works, starting with the audio preamplifier.

Fig.1 shows the circuit details, with just the left channel preamp stages shown for clarity, along with the power supply. The right channel preamp circuitry is identical to the left.

The audio signal from the source is AC-coupled to the input of the first op amp (IC1a) via a 4.7 $\mu$ F capacitor, while a 22k $\Omega$  resistor to ground provides input termination. In addition, the signal passes via a low-pass filter formed by a 100 $\Omega$  resistor, a ferrite bead and a 560pF capacitor. This attenuates radio frequencies (RF) ahead of the op amp input.

IC1a operates with a voltage gain of two (+6dB) by virtue of the 4.7k $\Omega$  feedback resistors. The 4.7k $\Omega$  resistor and 270pF capacitor combination roll off the top end frequency response, with a -3dB point at about 150kHz. This gives a flat response over the audio spectrum, while eliminating the possibility of high-frequency instability.

Note, however, that the -3dB high-frequency point for the entire amplifier is about 100kHz – see Fig.3.

The output from IC1a (pin 1) drives one end of potentiometer VR1a (20k $\Omega$ ) via a 22 $\mu$ F non-polarised coupling capacitor. The pot acts as a simple voltage divider and the signal on its wiper is fed to the input (pin 5) of op amp IC1b, via a 100 $\Omega$  resistor.

The wiper of the pot is also AC-coupled, this time using a 1 $\mu$ F non-polarised capacitor. This is done to prevent any DC voltage appearing across the pot, which if present would cause an irritating sound during wiper movement.

IC1b is used as a unity-gain buffer. This stage allows the preamp to provide a low-impedance output regardless of volume control setting. A 22 $\mu$ F non-polarised capacitor couples the audio signal to the output via a 100 $\Omega$  resistor, which is included to ensure stability when driving the cable and amplifier input capacitance. This resistor, together with the ferrite bead in series with the output, also helps to attenuate RF noise that might otherwise find its way back into the preamp circuit.

## Power supply

Power for the circuit is derived directly from the  $\pm$ 22V terminals on

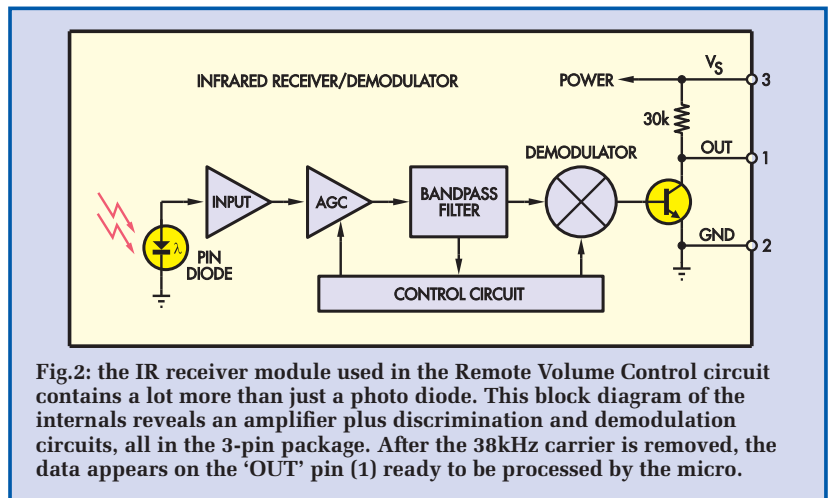

Fig.2: the IR receiver module used in the Remote Volume Control circuit contains a lot more than just a photo diode. This block diagram of the internals reveals an amplifier plus discrimination and demodulation circuits, all in the 3-pin package. After the 38kHz carrier is removed, the data appears on the 'OUT' pin (1) ready to be processed by the micro.

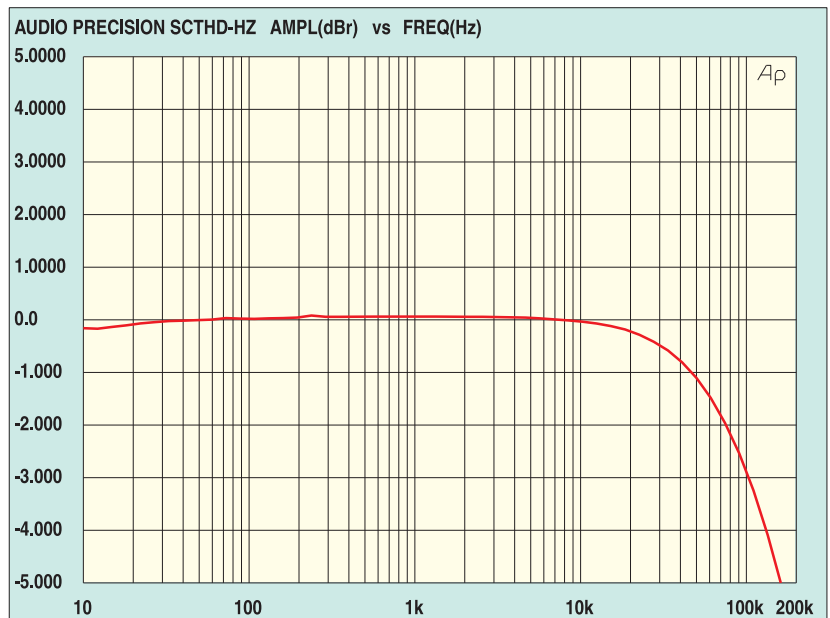

Fig.3: this graph shows the frequency response of the whole amplifier (including the preamplifier), taken at a power level of 1W into 8 $\Omega$ . It's almost ruler flat from 10Hz to 20kHz and then rolls off gently to be -3dB down at about 100kHz.

the power supply board (described in Nov'08). Diodes D1 and D2 provide reverse polarity protection, after which each rail is further filtered using a 220 $\mu$ F electrolytic capacitor. Two 3-terminal voltage regulators – REG1 and REG2 – then provide  $\pm$ 15V supply rails to power the op amps.

In addition, +22V and 0V outputs are provided from the power supply (via a separate terminal block – CON5). These outputs are used to power last month's Loudspeaker Protector and Muting Module when the amplifier is finally assembled.

## Remote volume control circuit

Now let's take a look at the circuit for the Remote Volume Control – see Fig.4. The three critical components are the PIC16F88-I/P microcontroller (IC3), the motorised potentiometer and an infrared receiver/detector module (IRD1).

In operation, the microcontroller monitors the demodulated infrared signal from IRD1. It then decodes this signal and drives the pot motor according to the RC5 code (see panel) sent by the handheld remote.

Sensor IRD1 only has three leads, but it is not a simple device; in reality,

# Constructional Project

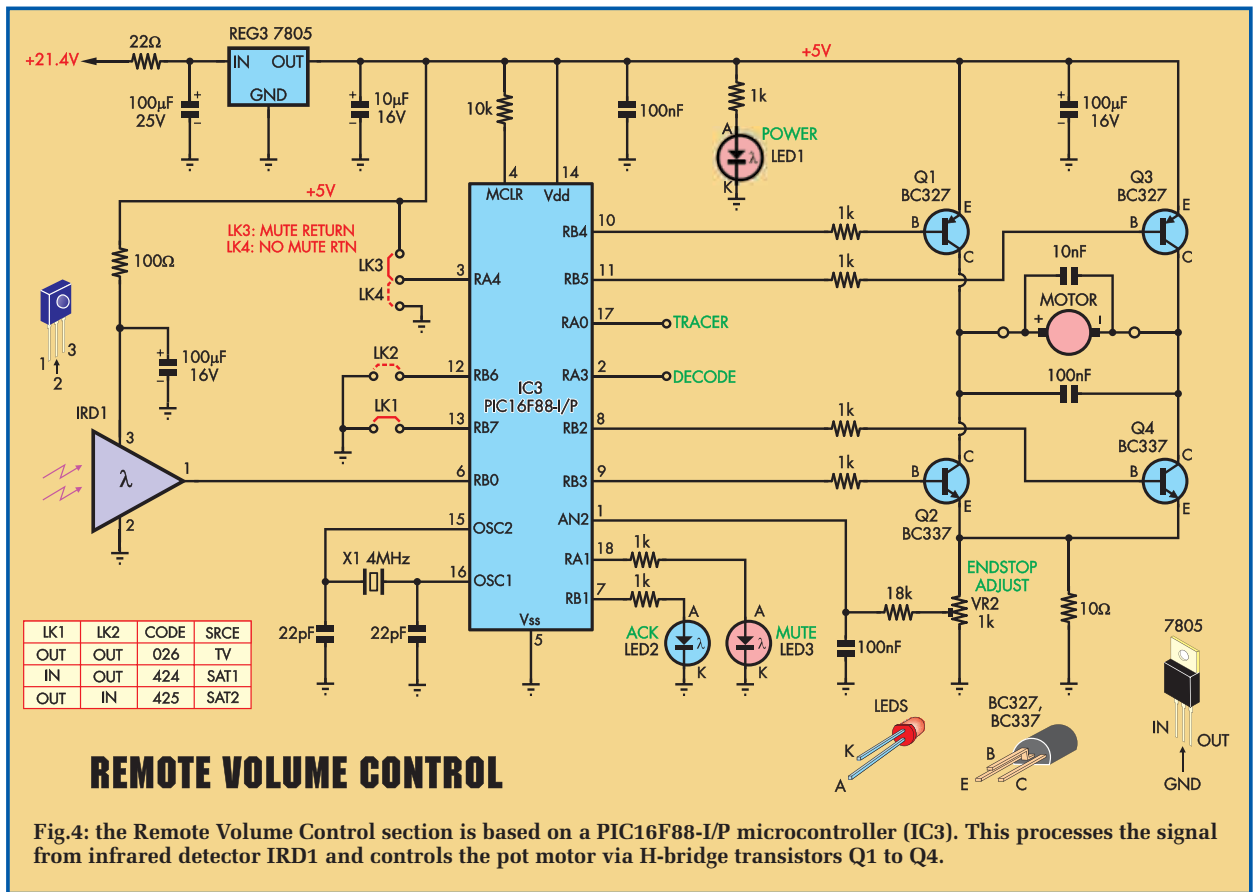

Fig.4: the Remote Volume Control section is based on a PIC16F88-I/P microcontroller (IC3). This processes the signal from infrared detector IRD1 and controls the pot motor via H-bridge transistors Q1 to Q4.

it is a complete infrared detector and processor – see Fig.2. First, it picks up the 38kHz infrared pulse signal from the remote control and amplifies this to a constant level. This is then fed to a 38kHz bandpass filter and then demodulated to produce a serial data burst at IRD1's pin 1 output.

From there, the demodulated signal from IRD1 is fed into IC3's RB0 input (pin 6). Operating under program control, the microcontroller then re-constitutes the demodulated data into byte-wide format using the Philips RC5 protocol specification.

Basically, the Remote Volume Control can be operated on one of three modes within the RC5 Code. These are TV1, SAT1 and SAT2 and the desired code is selected using jumper links LK1 and LK2 at the RB7 and RB6 inputs of IC3.

Normally, both these inputs are pulled high via internal resistors in IC3, but they can be pulled low using links LK1 and LK2. In operation, IC3 monitors these inputs and compares the selected code with the incoming serial data from IRD1. If the detected code is correct, the

motorised potentiometer will be driven according to the pushbutton command sent by the remote control.

## Motor drive

The motorised potentiometer (VR1) is driven by four transistors (Q1 to Q4) arranged in an H-bridge configuration. These in turn are driven via the RB2 to RB5 outputs of IC3 via 1kΩ resistors.

The motor is off when the RB2 to RB5 outputs are all set high. Ports RB4 and RB5 turn PNP transistors Q1 and Q3 off, while RB2 and RB3 turn NPN transistors Q2 and Q4 on. As a result, both terminals of the motor are pulled low and so the motor is off. Note that the emitters of Q2 and Q4 both connect to ground via a common 10Ω resistor (more on this shortly).

The transistors operate in pairs so that the motor can be driven in either direction (to increase or decrease the volume). To drive potentiometer VR1 clockwise, port RB3 goes low and turns off transistor Q2, while RB4 goes low and turns on Q1. This means that the lefthand terminal of the motor is taken to +5V

via transistor Q1, while the righthand terminal of the motor is held low via Q4. As a result, current flows through Q1, through the motor and then via Q4 and the 10Ω resistor to ground.

Conversely, to spin the motor in the other direction, transistors Q1 and Q4 are switched off and Q2 and Q3 are switched on. As a result, the righthand motor terminal is pulled to +5V via Q3, while the lefthand terminal is pulled low via Q2.

The voltage across the motor depends on the voltage across the common 10Ω emitter resistor and that in turn depends on the current. Typically, the motor draws about 40mA when driving potentiometer VR1, but this rises to over 50mA when the clutch is slipping. As a result, the motor voltage is around 4.5V to 4.6V due to the 0.4 to 0.5V drop across the 10Ω resistor (the rated motor voltage is 4.5V).

## Current sensing and muting

Once the pot's wiper reaches its fully clockwise or anti-clockwise position, a friction-type clutch in the gearbox

begins to slip. This prevents the motor from stalling, while also allowing the user to manually rotate the pot shaft if necessary.

The muting function depends on the microcontroller's ability to detect when the wiper is 'on the stops'. It does this by indirectly detecting the increase in the motor current.

In operation, preset VR2 samples the voltage across the 10Ω resistor when the motor is running. The resulting signal at its wiper is then filtered using an 18kΩ resistor and a 100nF capacitor (to remove the commutator hash from the motor) and applied to IC3's analogue AN2 input (pin 1).

This analogue input is measured (by IC3) to a resolution of 10-bits, or about 5mV. Provided this input is below 200mV, the PIC microcontroller allows the motor to run. However, as soon as the voltage rises above this 200mV limit, the motor is stopped.

When the motor is running normally, the current through it is about 40mA which produces 0.4V across the 10Ω resistor. Trimpot VR2 is used to attenuate this voltage and is adjusted so that the voltage at AN2 is slightly below the 200mV limit.

When the motor reaches the end of its travel, the extra load imposed by the slipping clutch increases the current and the voltage applied to the AN2 input rises above 200mV. This is detected by IC3 during muting and the microcontroller then switches the H-bridge transistors (Q1 to Q4) accordingly, to immediately stop the motor.

Note that AN2 is monitored only during the Muting operation. At other times, when the volume is being set by the Up or Down buttons on the remote control, the voltage at AN2 is not monitored. As a result, the clutch in the motor's gearbox assembly simply slips when potentiometer VR1 reaches its clockwise or anticlockwise limits.

Pressing the Mute button on the remote again after muting returns the volume control to its original setting. This is the 'Mute Return' feature referred to earlier.

Note also that connecting IC3's RA4 input to ground via link LK4 disables this feature. Conversely, to enable Mute Return, link LK3 is used to pull RA4 to +5V.

## Indicator LEDs

LEDs 1 to 3 indicate the status of the circuit. The red Power LED (LED1) lights

## Parts List – Preamp & Remote Volume Control

- |  |  |         |       |        |        |        |       |        |       |         |  |
|--|--|---------|-------|--------|--------|--------|-------|--------|-------|---------|--|
| <ul style="list-style-type: none"> <li>1 PC board, code 696, available from the <i>EPE PCB Service</i>, size 201 × 63mm</li> <li>1 Alpha dual-ganged 20kΩ log motorised pot (VR1) (Altronics Cat. R2000)</li> <li>1 1kΩ (code 102) horizontal trimpot (VR2)</li> <li>1 DIP 18-pin IC socket</li> <li>2 DIP 8-pin IC sockets</li> <li>5 2-way PC-mount screw terminal blocks, 5.08mm spacing (Altronics Cat. P2034A – <b>do not substitute</b>)</li> <li>1 3-way PC-mount screw terminal block, 5.08mm spacing (Altronics Cat. P2035A – <b>do not substitute</b>)</li> <li>1 4MHz crystal (X1)</li> <li>4 ferrite beads (Altronics Cat. L5250A)</li> <li>1 3-way SIL pin header, 2.54mm spacing</li> <li>1 2-way SIL pin header, 2.54mm spacing</li> <li>1 2-way DIL pin header, 2.54mm spacing</li> <li>2 jumper links to suit headers</li> <li>1 6.35mm panel-mount single-ended spade connector</li> <li>1 6.35mm spade connector</li> <li>4 M3 × 25mm tapped standoffs</li> <li>4 M3 × 6mm screws</li> <li>1 M4 × 10mm screw</li> <li>1 M4 nut</li> <li>1 M4 flat washer</li> <li>1 M4 star washer</li> <li>1 250mm length of 0.8mm tinned copper wire</li> <li>1 150mm length of red hook-up wire</li> </ul> | <ul style="list-style-type: none"> <li>1 150mm length of black hook-up wire</li> <li>2 100mm cable ties</li> </ul> <p><b>Semiconductors</b></p> <ul style="list-style-type: none"> <li>2 LM4562 op amps (IC1, IC2)</li> <li>1 PIC16F88-I/P programmed with 'Low Noise Preamp Volume.hex' (IC3)</li> <li>1 infrared decoder (IRD1)</li> <li>1 7815 +15V regulator (REG1)</li> <li>1 7915 – 15V regulator (REG2)</li> <li>1 7805 +5V regulator (REG3)</li> <li>2 BC327 PNP transistors (Q1, Q3)</li> <li>2 BC337 NPN transistors (Q2, Q4)</li> <li>1 3mm red LED (LED1)</li> <li>1 3mm blue LED (LED2)</li> <li>1 3mm orange LED (LED3)</li> </ul> <p><b>Capacitors</b></p> <ul style="list-style-type: none"> <li>2 220μF 25V PC electrolytic</li> <li>1 100μF 25V PC electrolytic</li> <li>4 100μF 16V PC electrolytic</li> <li>4 22μF NP electrolytic</li> <li>1 10μF 16V PC electrolytic</li> <li>2 4.7μF NP electrolytic</li> <li>2 1μF NP electrolytic or MKT polyester</li> <li>5 100nF MKT polyester</li> <li>1 10nF MKT polyester</li> <li>2 560pF ceramic</li> <li>2 270pF ceramic</li> <li>2 22pF ceramic</li> </ul> <p><b>Resistors</b> (0.25W 1% carbon film)</p> <table border="0"> <tr> <td>4 100kΩ</td> <td>7 1kΩ</td> </tr> <tr> <td>2 22kΩ</td> <td>7 100Ω</td> </tr> <tr> <td>1 18kΩ</td> <td>1 22Ω</td> </tr> <tr> <td>1 10kΩ</td> <td>1 10Ω</td> </tr> <tr> <td>4 4.7kΩ</td> <td></td> </tr> </table> | 4 100kΩ | 7 1kΩ | 2 22kΩ | 7 100Ω | 1 18kΩ | 1 22Ω | 1 10kΩ | 1 10Ω | 4 4.7kΩ |  |
| 4 100kΩ  | 7 1kΩ  |         |       |        |        |        |       |        |       |         |  |
| 2 22kΩ   | 7 100Ω   |         |       |        |        |        |       |        |       |         |  |
| 1 18kΩ   | 1 22Ω  |         |       |        |        |        |       |        |       |         |  |
| 1 10kΩ   | 1 10Ω  |         |       |        |        |        |       |        |       |         |  |
| 4 4.7kΩ  |  |         |       |        |        |        |       |        |       |         |  |

whenever power is applied to the circuit and provides power on/off indication for the entire amplifier.

The other two LEDs – Ack (acknowledge) and Mute – light when their respective RB1 and RA1 outputs are pulled high (to +5V). As explained previously, the Ack LED flashes whenever the RB0 input receives an infrared signal from the remote control, while the Mute LED flashes during the Mute operation and then stays lit while the volume remains muted.

## Crystal oscillator

Pins 15 and 16 of IC3 are the oscillator inputs for the 4MHz crystal X1, which is used to provide the clock signal. This oscillator runs when the circuit is first

powered up for about 1.5 seconds. It also runs whenever an infrared signal (IR) is received at RB0 and then for a further 1.5 seconds after the last receipt of a signal, after which the oscillator shuts down.

Note, however, that this shut down does not occur if a Muting operation is still in process.

Shutting down the oscillator in the absence of an infrared signal from the remote control ensures that no noise is radiated into sensitive audio circuitry when the volume control is not being altered.

## Waking up again

As just stated, when there is no IR signal from the remote, the circuit goes to 'sleep' (ie, the oscillator shuts down)

# Constructional Project

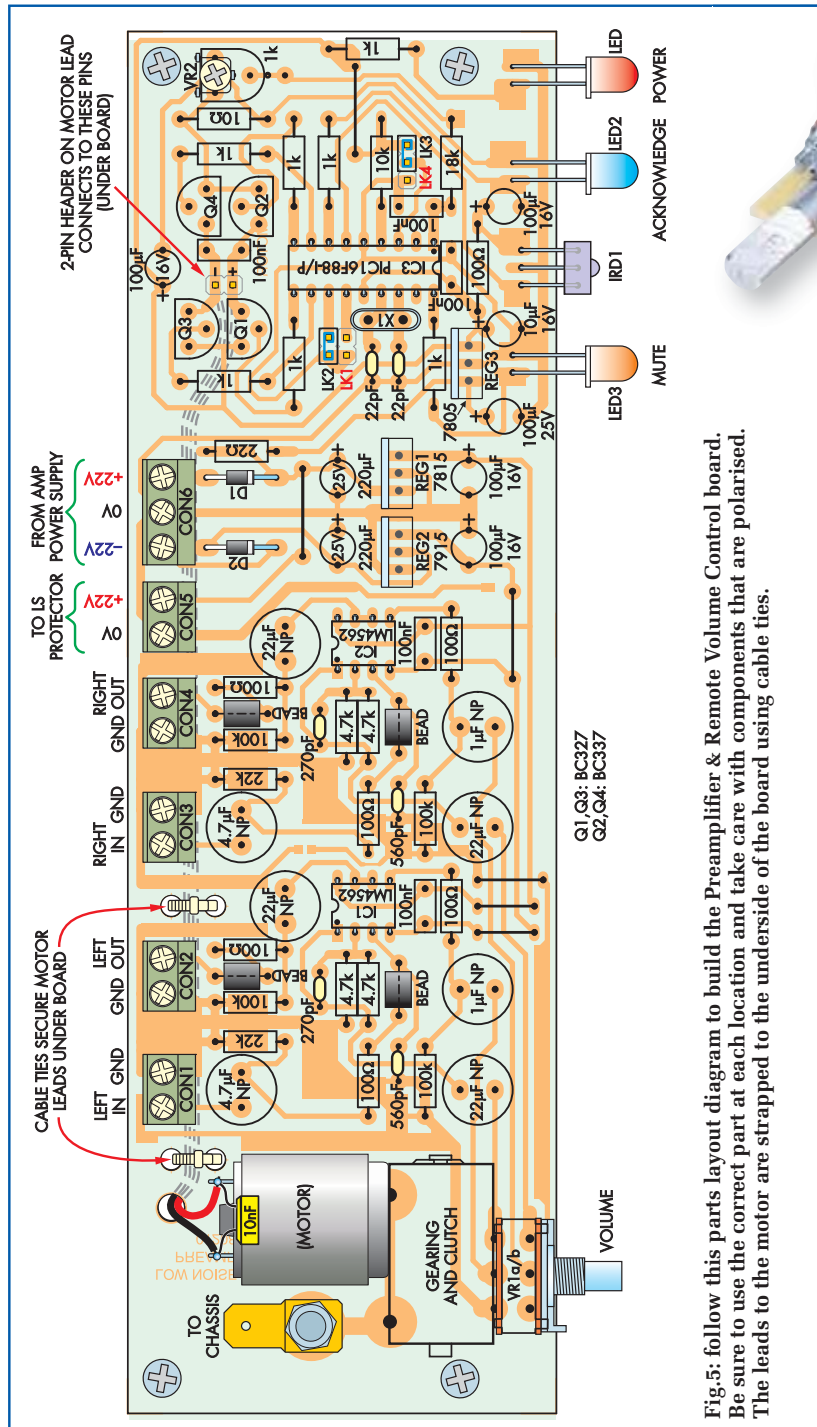

Fig.5: follow this parts layout diagram to build the Pre-amplifier & Remote Volume Control board. Be sure to use the correct part at each location and take care with components that are polarised. The leads to the motor are strapped to the underside of the board using cable ties.

and so no noise is produced. However, as soon as it receives an IR signal, the circuit 'wakes up' and drives potentiometer VR1. It then shuts down after about 1.5 seconds if it does not receive any further IR signals. In addition, the potentiometer drive motor is enclosed by a Mumetal shield,

which reduces any radiated electrical hash from the motor's commutator brushes. A 10nF capacitor connected directly across the motor terminals also prevents commutator hash from being transmitted along the connection leads, while further filtering is provided by a 100nF capacitor located

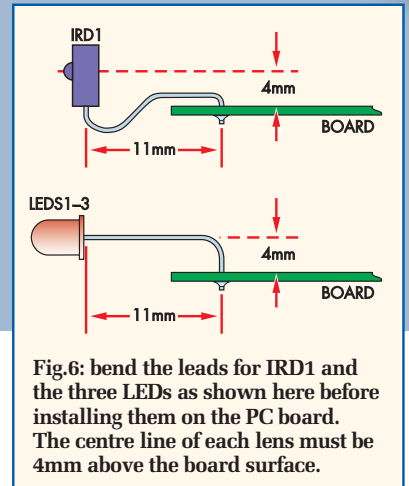

Fig.6: bend the leads for IRD1 and the three LEDs as shown here before installing them on the PC board. The centre line of each lens must be 4mm above the board surface.

at the motor output terminals on the PCB board.

## Coding options

Links LK1 and LK2 at RB7 and RB6 are used to program the different infrared coding options. The default selection is when both ports RB6 and RB7 are pulled high via their internal pull-up resistors – ie, when LK1 and LK2 are out. This selects the TV1 infrared remote control code and this will be suitable for most applications.

However, this code may also operate your TV and so we have provided options to select another code to prevent this from happening. The inset table in Fig.4 shows the linking options used to select either the SAT1 or SAT2 code. For example, installing LK2 (and leaving LK1 out) sets the code to SAT2.

Power for the circuit is derived from the amplifier's 22V DC supply and is fed in via a 22Ω resistor and a 100μF decoupling capacitor. The resulting rail is then applied to regulator REG3, which produces a +5V supply rail to power IC3, IRD1 and the H-bridge driver stage for

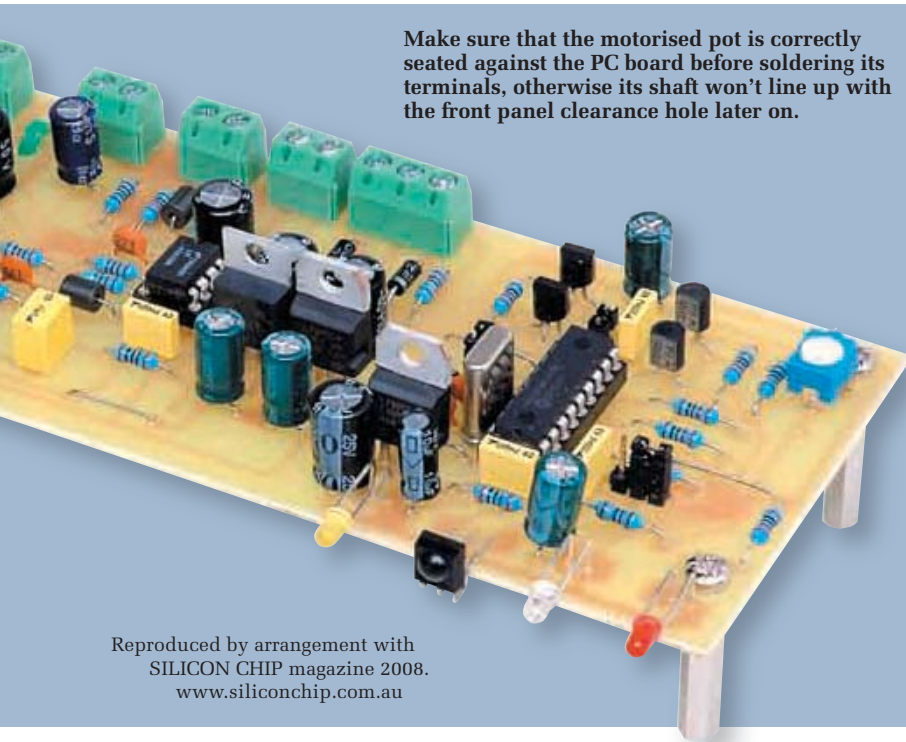

Make sure that the motorised pot is correctly seated against the PC board before soldering its terminals, otherwise its shaft won't line up with the front panel clearance hole later on.

Reproduced by arrangement with SILICON CHIP magazine 2008. [www.siliconchip.com.au](http://www.siliconchip.com.au)

the motor. A 10µF capacitor decouples the output of REG3, while the 100µF capacitor across IRD1 prevents this device from false triggering due to 'hash' on the +5V rail.

### Software

The software files are available for download via the *EPE* Downloads site, access via [www.epemag.com](http://www.epemag.com). Pre-programmed PICs are available from **Magenta Electronics** – see their advert in this issue for contact details.

### Construction

All the parts for the Preamp & Remote Volume Control Unit are installed on a single PC board, coded 696, measuring 201 × 63mm. This

board is available from the *EPE PCB Service*.

The external connections to the power supply and to the audio input and output cables are run via insulated screw terminal blocks. Fig.5 shows the assembly details.

As usual, begin by checking the board for defects and for the correct hole sizes. In particular, check that the motorised pot and the screw terminal blocks fit correctly and that the mounting holes are correct.

That done, start the assembly by installing the six wire links. You can straighten the link wire by securing one end in a vice and then pulling on the other end using a pair of pliers, to stretch it slightly. The resistors can then go in.

Table 1 shows the resistor colour codes, but you should also check them using a digital multimeter, as the colours can sometimes be difficult to decipher.

Next on the list are the four ferrite beads. These each have a wire link run through them, which is then soldered to the board. Follow these with the two diodes (D1 and D2), then install sockets for the three ICs. Make sure that each socket is oriented correctly (IC3 faces in the opposite direction to ICs 1 and 2) and that it's seated properly against the PC board.

In fact, it's best to solder two diagonally opposite pins of a socket first and then check it before soldering the remaining pins.

The MKT polyester and ceramic capacitors can now go in, followed by the non-polarised capacitors and the polarised electrolytics. Make sure that the latter are all correctly oriented and note that the 100µF capacitor to the left of LED3 must be rated at 25V (the other 100µF capacitors can all be rated at 16V).

Now install the transistors and 3-terminal regulators. Transistors Q1 to Q4 all go in the remote volume control section and must be oriented as shown. Be sure to use the correct type at each location. Q1 and Q3 are both BC327s, while Q2 and Q4 are BC337s. Don't get them mixed up.

The same goes for the three regulators. REG1 is a 7815, REG2 a 7915 and REG3 a 7805 – again, don't mix them up. These parts should all be inserted as far down as they will go, with their metal tabs facing towards the back of the board. No heatsinking is required for their metal tabs, since current requirements are only modest.

The 2-way DIL (dual-in-line) pin header for LK1 and LK2 can now be installed, followed by the 3-way header for LK3 and LK4. A 2-way pin header is

**Table 1: Resistor Colour Codes**

	No.	Value	4-Band Code (1%)	5-Band Code (1%)
□	4	100kΩ	brown black yellow brown	brown black black orange brown
□	2	22kΩ	red red orange brown	red red black red brown
□	1	18kΩ	brown grey orange brown	brown grey black red brown
□	1	10kΩ	brown black orange brown	brown black black red brown
□	4	4.7kΩ	yellow violet red brown	yellow violet black brown brown
□	7	1kΩ	brown black red brown	brown black black brown brown
□	6	100Ω	brown black brown brown	brown black black black brown
□	1	22Ω	red red black brown	red red black gold brown
□	1	10Ω	brown black black brown	brown black black gold brown

## Avoiding an earth loop with IRD1

If the supplied infrared receiver (IRD1) includes an external metal shield (see photo), then steps must be taken to insulate it from the chassis when the preamplifier is installed. That's because the shield is connected to the centre (GND) terminal of the device and a short between the shield and the metal chassis would create an earth loop. And that in turn would inject hum into the audio signal.

One method is to attach a short strip of insulation tape to the inside of the front panel, with a hole cut out to match the hole in the panel. Alternatively, it should be possible to insulate the front of the device and arrange it so that it just stands clear of the front panel.



If your infrared receiver module has a metal shield like this one, then be sure to insulate it from the front panel as described in the accompanying text.

**Do not rely on the powder coating on the chassis to provide insulation! That's asking for trouble.**

with previous boards, it's held in place using an M4 screw, a flat washer, a shakeproof washer and a nut (see Fig.3 last month).

### Initial checks

Before plugging in any of the ICs, it's a good idea to check the supply voltages. However, if you don't have the power supply running yet (or a suitable bench power supply), this can wait until the final assembly in the chassis.

Assuming you do have a power supply, connect the +22V, -22V and 0V leads to CON6 and switch on. Now check the voltages on pins 8 and 4 of the two 8-pin IC sockets (ie, between each of these pins and 0V). You should get readings of +15V (pin 8) and -15V (pin 4) respectively.

Similarly, check the voltage on pin 14 of IC3's socket – you should get a reading between 4.8V and 5.2V.

If these voltages are correct, switch off and plug the ICs into their sockets, taking care not to zap them with static electricity. Note that IC1 and IC2 face one way, while IC3 faces the other way.

### Remote volume control testing

If you don't have a dual power supply, you can check just the remote volume control section using a single rail 9V to 15V supply (connect this between the +22V and 0V terminals on CON6). As before, check the voltage on pin 14 of IC3's socket (it must be between 4.8V and 5.2V), then switch off and plug IC3 into its socket.

In addition, insert the jumper link for LK3, to enable the Mute return feature, but leave LK1 and LK2 out for the time being (to accept the TV code from the remote control).

Further testing requires a universal remote control. These range from single TV remote controls with limited functions to elaborate models capable of operating many different types of equipment.

Note, however, that simple TV remote controls will only operate this project using the TV code (026). That can cause problems if you have a Philips TV set located in the same vicinity as the amplifier, because the remote control will probably operate the TV as well. This is easy to solve – just use a multi-item remote control so that a different code can be used (either 424 for SAT1 or 425 for SAT2)

An example of a TV-only remote control is the Jaycar AR-1703. Multi-item

also used to terminate the motor leads (just to the right of Q1 and Q3). To install this header, first push its pins down so that their ends are flush with the top of the plastic, then install the header from the component side and solder the pins underneath.

This will give about 7mm pin lengths to terminate the leads from the motor, which are run underneath the PC board.

Crystal X1 (adjacent to IC3) can be installed either way around. Make sure it's seated correctly before soldering its leads, then install trimpot VR2 and the six screw terminal blocks. Be sure to use the screw terminal blocks specified in the parts list – they give more reliable connections when terminating thin audio cable leads than the type used on our prototype.

### Mounting the motorised pot

It's absolutely critical to seat the motorised pot (VR1) correctly against the PC board before soldering its leads. If this is not done, then it won't line up correctly with its clearance hole in the amplifier's front panel later on.

In particular, note that the two lugs at the rear of the gearbox cover go through slotted holes in the PC board. Use a small jeweller's file to enlarge these if necessary.

Once the pot fits correctly, solder two diagonally opposite pot terminals and check that everything is correct before soldering the rest. The two gearbox cover lugs can then be soldered.

Once the pot is in place, the motor terminals can be connected to the two

pin header at the other end of the board using light-duty hook-up cable. These leads are twisted together to keep them tidy and pass through a hole in the board immediately behind the motor. As shown, they are then secured to the underside of the PC board using cable ties and connected to the header pins (watch the polarity).

Don't forget to solder the 10nF capacitor directly across the motor terminals. As previously stated, it's there to suppress motor hash.

### Mounting the LEDs

Fig.6 shows the mounting details for the infrared receiver (IRD1) and the three LEDs. As shown, the centre line of each lens must be 4mm above the board surface.

So how do you mount the LEDs accurately? Easy – just cut 11mm wide and 4mm wide templates from thick cardboard. The 11mm template serves as a lead bending guide, while the 4mm template is used as a spacer when mounting the LEDs – just push each LED down onto the spacer and solder its leads.

Hint: you can use sticky tape as a 'third hand' to hold each LED and the template in place during soldering.

IRD1's leads should also be bent as shown in Fig.6 and the photos. This will allow a small amount of 'give' in the leads when the lens later contacts the back of the front panel (ie, it will allow IRD1 to 'spring' back slightly and keep the lens against the panel).

Finally, complete the board assembly by installing the quick connector. As

remote controls include the Altronics A-1009 and the Jaycar AR-1714.

## Programming the remote

The best approach here is to initially program the remote control for a Philips brand TV (just follow the instructions supplied with the unit). In most cases, programming involves simultaneously pressing the 'Set' button and the button for the item that is to be operated. In other words, press the Set and TV buttons together and enter a number for a Philips TV set.

In this case, the Altronics A-1009 uses the number 026 or 191 and the Jaycar AR-1703 uses 11414. If you are using a different remote control, just select a number for a Philips TV set. If you later find that this doesn't work, try another number for a Philips TV.

Having programmed the remote, rotate trimpot VR2 fully anticlockwise. That done, check that the motor turns the potentiometer clockwise when the remote's Volume Up and Channel Up buttons are pressed.

It should travel fairly quickly when Volume Up is pressed and at a slower rate when Channel Up is used.

Now, check that the volume pot runs anticlockwise using the Volume Down and Channel down buttons. If it turns in the wrong direction, simply reverse the leads to the motor. Check that the blue Acknowledge LED flashes each time you press a button on the remote.

Next, set the pot to mid-position and hit the Mute button. The pot will rotate anti-clockwise and as soon as it hits the stops, the clutch will start to slip. While this is happening, slowly adjust VR2 clockwise until the motor stops.

Now press Volume Up to turn the potentiometer clockwise for a few seconds and press Mute again. This time, the motor should stop as soon as the pot reaches its minimum position.

Note that a programmed timeout of 13 seconds will also stop the motor (if it hasn't already stopped) after Mute is activated. This means that you have to adjust VR2 within this 13s period, otherwise the timeout will stop the motor.

If it stops prematurely or fails to stop at all (ie, the motor runs for the full 13 seconds), try redoing the adjustment. Once the adjustment is correct, pressing the Mute button a second time should accurately return the potentiometer to its original position.

## Universal infrared remote controls

The Remote Volume Control circuit is designed to work with most universal ('one-for-all') infrared remotes. It recognises the RC5 protocol that was originally developed by Philips, so the remote must be programmed for a Philips (or compatible) appliance before use.

Most universal remotes are provided with a long list of supported appliances and matching codes. To set the remote to work with a particular piece of gear, it's usually just a matter of entering the code listed for the manufacturer (in this case, Philips), as detailed in the instructions.

You'll also note that different codes are provided for TV, CD, SAT, and so on. This allows two or more appliances from the same manufacturer to be operated in the same room and even from the same handpiece.

This multiple addressing capability can also be useful in our application too. Normally, we'd program the remote to control a TV, as this works with the control module. But what if you already have a Philips TV (or some other model that uses the RC5 protocol)? Well, in that case, you simply use the SAT1 or SAT2 code instead, as the Remote Volume Control can also handle these.

Typically, to set a remote to control a Philips TV, you first press and hold 'SET' and then press 'TV'. This puts the remote in programming mode, as indicated by an LED, which should remain illuminated.

You then release both keys and punch in one of the listed Philips TV codes. For this project, code 026 works well. The red LED should then go out, after which the remote is ready for use. All universal remotes can be programmed in a similar manner, but if in doubt, try reading the instructions. If the first code listed doesn't work with the Remote Volume Control, then try another.

Once the remote has been programmed, the Remote Volume Control must be set up to recognise the particular equipment address that you've chosen (either TV, SAT1 or SAT2). The details on how to do this are in the main text.

Although this project should work with any universal remote, we've tested the following popular models: AIFA Y2E (Altronics A-1013), AIFA RA7 (Altronics A-1009) and Jaycar AR-1703. For all these models, the set-up codes are as follows: TV = 026, SAT1 = 424 and SAT2 = 425. Note, however, that the AIFA Y2E doesn't have a mute button.

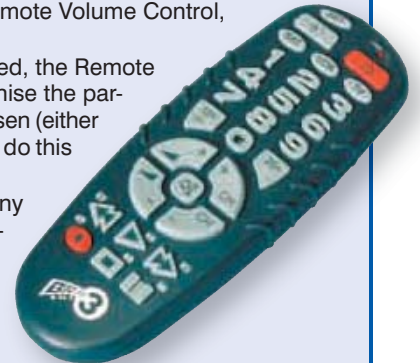

As mentioned earlier, links LK1 and LK2 change the codes for the infrared transmission – see the table in Fig.4. You will only need to install one of these links (to select SAT1 or SAT2) if you have a Philips TV. Remove link LK3 and install link LK4 if the Mute return feature is not required.

Note that with a new motorised potentiometer, the clutch will require a little 'wearing in' to evenly spread the lubricant in the slipping sections. This can be done simply by turning the pot shaft by hand a few times before use. Readjust VR2 for best results after you do this.

## Avoiding a hum loop

Finally, note that the power supply earth (0V) is *not* connected to the left and right channel earth tracks on the preamplifier PC board. This avoids a hum loop, since the two channels are normally earthed back through the power amplifiers via their signal leads.

**However, if you want to use the preamp on its own, both the left and right channel signal earths on the board must be connected to the 0V rail for the power supply. This can be done by connecting insulated wire links between the relevant screw terminal blocks.**



## Constructional Project

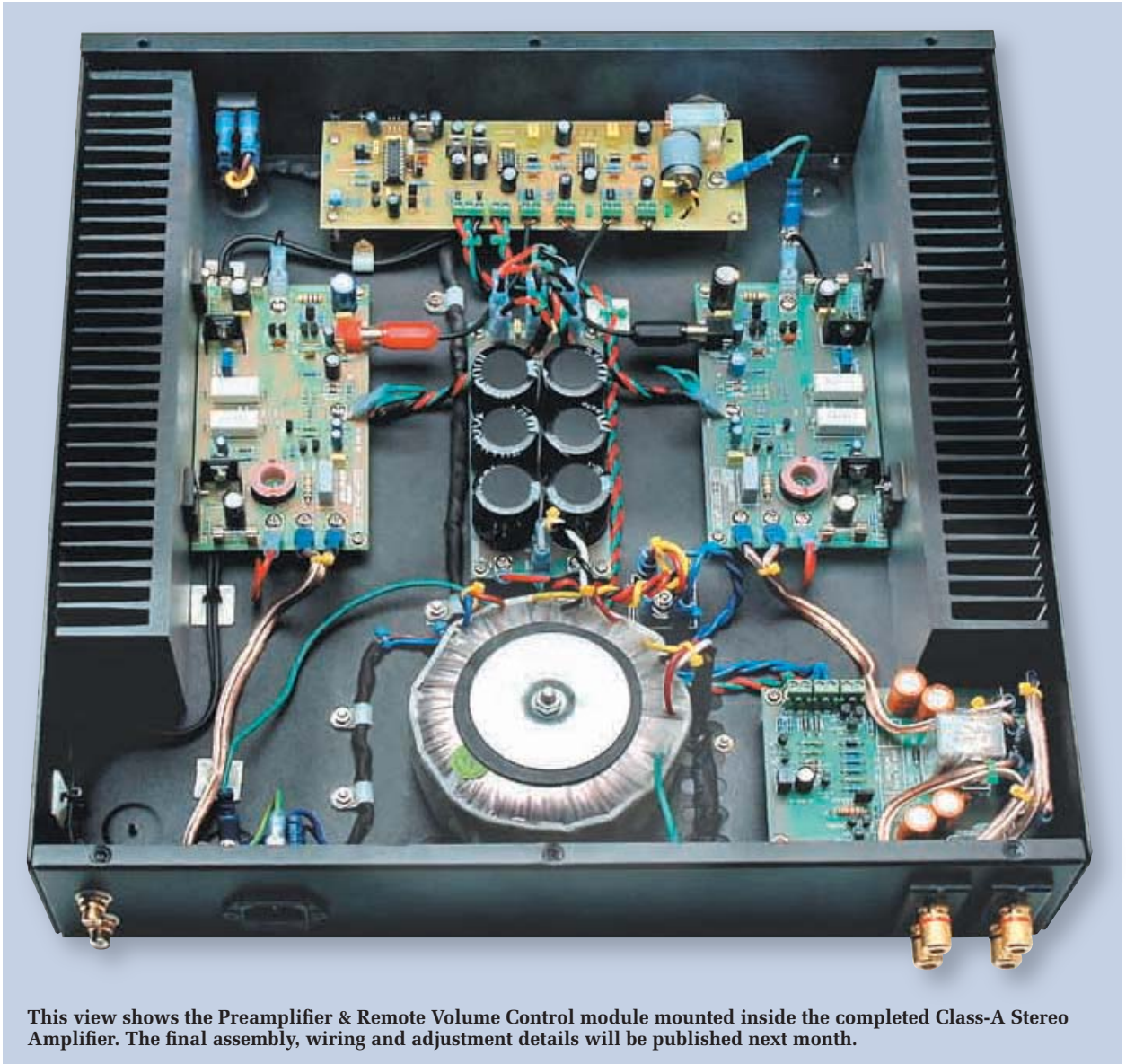

This view shows the Preamplifier & Remote Volume Control module mounted inside the completed Class-A Stereo Amplifier. The final assembly, wiring and adjustment details will be published next month.

That's all for this month. In Part 5, we'll show you how to assemble all the modules into a custom metal chassis to produce a complete high-quality class-A stereo audio amplifier. *EPE*

**EPE**  
Online  
[www.epemag.com](http://www.epemag.com)

Get your magazine 'instantly' anywhere in the world – buy and download from the web.

**TAKE A LOOK, A FREE ISSUE IS AVAILABLE**

A one year subscription (12 issues) costs just \$18.99(US)

Back issues are also available

**Laser**  Why tolerate when you can automate?

 Home Automation	 C-Bus Shop C-Bus and C-Bus Wireless
 KAT5 AV transmission and IR control system	<a href="http://www.cbus-shop.com">www.cbus-shop.com</a>
 Barix Ethernet based MP3, communications and control systems	<a href="http://www.laser.com">www.laser.com</a>
<a href="http://www.laser.com">www.laser.com</a>	Laser Business Systems Ltd Tel: +44 (0) 20 8441 9788 Fax: +44 (0) 20 8449 0430 Email: <a href="mailto:info@laser.com">info@laser.com</a> 16 Garthland Drive, ENS 3BB
Integrators, Installers, Trade and Retail customers welcome	

# Learn About Microcontrollers



## P928 PIC Training Course £164

The best place to begin learning about microcontrollers is the PIC16F627A. This is very simple to use, costs just £1.30, yet is packed full of features including 16 input/output lines, internal oscillator, comparator, serial port, and with two software changes is a drop in replacement for the PIC16F84.

Our PIC training course starts in the very simplest way. At the heart of our system are two real books which lie open on your desk while you use your computer to type in the programme and control the hardware. Start with four simple programmes. Run the simulator to see how they work. Test them with real hardware. Follow on with a little theory.....

Our PIC training course consists of our PIC programmer, a 318 page book teaching the fundamentals of PIC programming, a 262 page book introducing the C language, and a suite of programmes to run on a PC. The module uses a PIC to handle the timing, programming and voltage switching. Two ZIF sockets allow most 8, 18, 28 and 40 pin PICs to be programmed. The programming is performed at 5 volts, verified with 2 volts or 3 volts and verified again with 5.5 volts to ensure that the PIC works over its full operating voltage. UK orders include a plugtop power supply.

P928-V PIC Training & Development Course comprising.....

- Enhanced 16C, 16F and 18F PIC programmer module
  - + Book Experimenting with PIC Microcontrollers
  - + Book Experimenting with PIC C
  - + PIC assembler and C compiler software on CD
  - + PIC16F627A, PIC16F88, PIC16F870 and PIC18F2321 test PICs
  - + USB adaptor and USB cable..... £164.00
- (Postage & insurance UK £10, Europe £18, Rest of world £27)

## Experimenting with PIC Microcontrollers

This book introduces PIC programming by jumping straight in with four easy experiments. The first is explained over seven pages assuming no starting knowledge of PICs. Then having gained some experience we study the basic principles of PIC programming, learn about the 8 bit timer, how to drive the liquid crystal display, create a real time clock, experiment with the watchdog timer, sleep mode, beeps and music, including a rendition of Beethoven's Fur Elise. Then there are two projects to work through, using a PIC as a sinewave generator, and monitoring the power taken by domestic appliances. Then we adapt the experiments to use the PIC16F877 family, PIC16F84 and PIC18F2321. In the space of 24 experiments, two projects and 56 exercises we work through from absolute beginner to experienced engineer level using the most up to date PICs.

## Experimenting with PIC C

The second book starts with an easy to understand explanation of how to write simple PIC programmes in C. Then we begin with four easy experiments to learn about loops. We use the 8/16 bit timers, write text and variables to the LCD, use the keypad, produce a siren sound, a freezer thaw warning device, measure temperatures, drive white LEDs, control motors, switch mains voltages, and experiment with serial communication.

Web site:- [www.brunningsoftware.co.uk](http://www.brunningsoftware.co.uk)

## PH28 Training Course £189

PIC training and Visual C# training combined into one course. This is the same as the P928 course with an extra book teaching about serial communication.

The first two books and the programmer module are the same as the P928. The third book starts with very simple PC to PIC experiments. We use PC assembler to flash the LEDs on the programmer module and write text to the LCD. Then we learn to use Visual C# on the PC. Flash the LEDs, write text to the LCD, gradually creating more complex routines until a full digital storage oscilloscope is created. (Postage & ins UK £10, Europe £20, rest of world £34).

## Mini Training Course £64

This course is based on the Brunning Software PIC slave which connects to a USB socket on your PC. The BSPslave has a programmable PIC which connects to LEDs, a push button, a sounder, a 16 character by 2 line display, and a 12 way i/o socket. We start with a simple programme to flash the LEDs. We pause the programme at critical points while it is running in the PIC, and view the PICs registers, a brilliant way to learn about PICs. We learn to generate sounds, study the timer and interrupts, and write text to the display. We study simple serial communication by sending text between the PIC and the PC. We use the analogue to digital converter and finish with a fully worked project to measure temperatures. Price includes a BSPslave, 180 page book, PIC assembler on CD, USB lead and project components (2 thermistors, resistors, capacitors, leads and connector). A perfect course for students and absolute beginners. (Postage & ins UK £5, Europe £10, rest of world £15).

## Ordering Information

Our P928 course is supplied with a USB adaptor and USB lead as standard but can be supplied with a COM port lead if required. All software referred to in this advertisement will operate within Windows XP, NT, 2000, Vista etc (For Windows 98, ME or DOS order P928-BS £159+pp).

Telephone with Visa, Mastercard or Switch, or send cheque/PO. All prices include VAT if applicable.

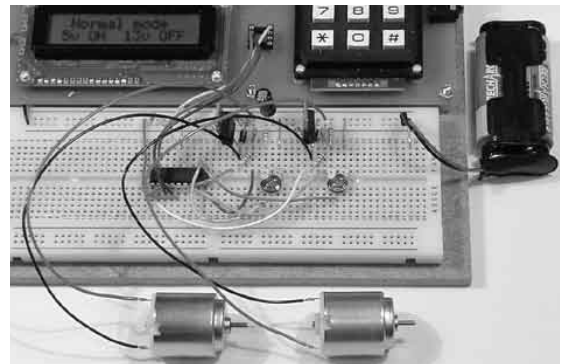

## White LED and Motors

Our PIC training system uses a very practical approach. Towards the end of the second book circuits need to be built on the plugboard. The 5 volt supply which is already wired to the plugboard has a current limit setting which ensures that even the most severe wiring errors will not be a fire hazard and are very unlikely to damage PICs or other ICs.

We use a PIC16F627A as a freezer thaw monitor, as a step up switching regulator to drive 3 ultra bright white LEDs, and to control the speed of a DC motor with maximum torque still available. A kit of parts can be purchased (£31) to build the circuits using the white LEDs and the two motors. See our web site for details.

Mail order address:

# Brunning Software

138 The Street, Little Clacton, Clacton-on-sea,  
Essex, CO16 9LS. Tel 01255 862308



In Part 1, we unveiled our low-cost microwave Doppler Radar Speed Gun, designed for measuring the speed of cars, bikes, boats, horses and even human sprinters. This month, we show you how to build it and describe how it is used.

Part 2: By JIM ROWE

# Build Your Own Radar Speed Gun

AS EXPLAINED in Part 1, all the components in our Doppler Radar Speed Gun are mounted on two PC boards. The smaller double-sided board contains the microwave head circuit, and fits inside a small shield box attached to the underside of the 'coffee-can' antenna barrel. By contrast, the larger board carries the counter/display unit circuit, and fits inside a standard UB1 type plastic utility box. The two units are linked by a single cable that's fitted with a Type A USB plug at each end.

Although the larger board has more components on it than the smaller board, it's a little easier to assemble because it's only single-sided and the components are all of the familiar standard 'lead' type. Therefore, we're going to assemble this board first.

### Counter/display board

Fig.5 shows the assembly details for the counter/display board. This board is available from the *EPE PCB Service*, code 695.

Begin construction by fitting the 10 wire links. These can all be made using tinned copper wire or resistor lead off-cuts, except for the one located just below transistor Q3. This link should be made from a short length of insulated hookup wire, because it runs quite close to a lead from the  $1k\Omega$  resistor just below it.

Once all the links are in place, fit the six 1mm PC board terminal pins that are used for the three test points, also fit their accompanying ground connections.

Note that as supplied, the counter/display board is configured to show readings in km/h. If you want the

display to read in mph instead, then it's just a matter of cutting the three tracks between the centre and top terminals of LK1, LK2 and LK3 and installing wire links between the centre and bottom terminals instead.

Alternatively, you can fit 3-pin headers in the LK1-LK3 positions and use 2-pin jumpers to make the connections instead. However, you will still have to cut the tracks between the top two terminals of the headers.

Now fit the IC sockets, taking care to orientate each one with its 'notch' end towards the left, as shown on the overlay diagram in Fig.5. This will help ensure that later, you fit the ICs the correct way around.

The resistors can go in next, followed by trimpot VR1. Note: you may wish

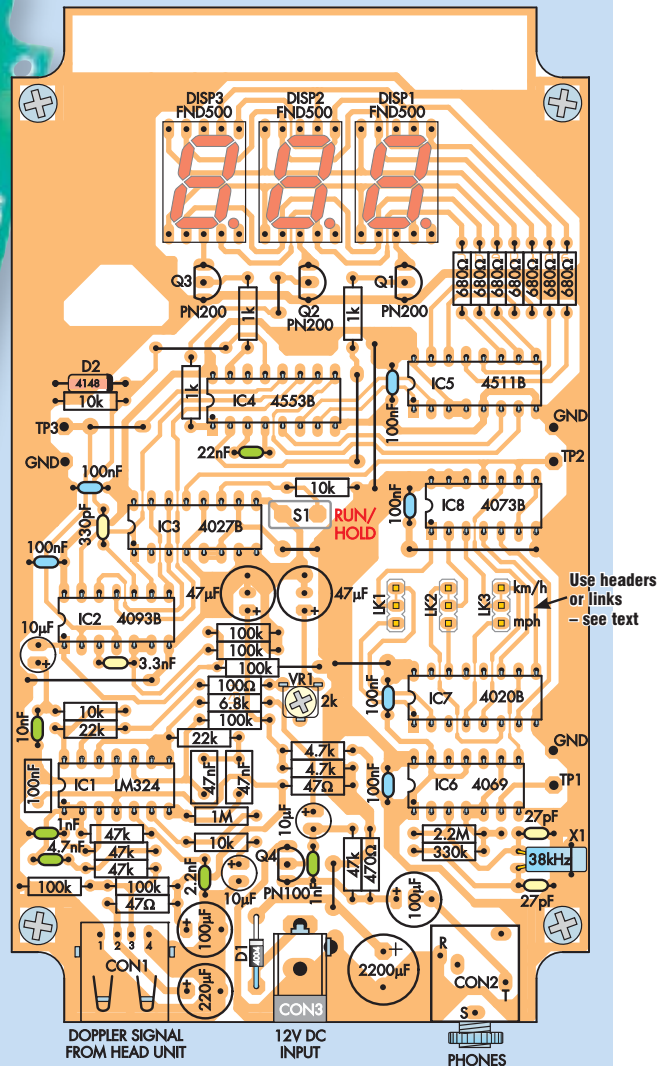
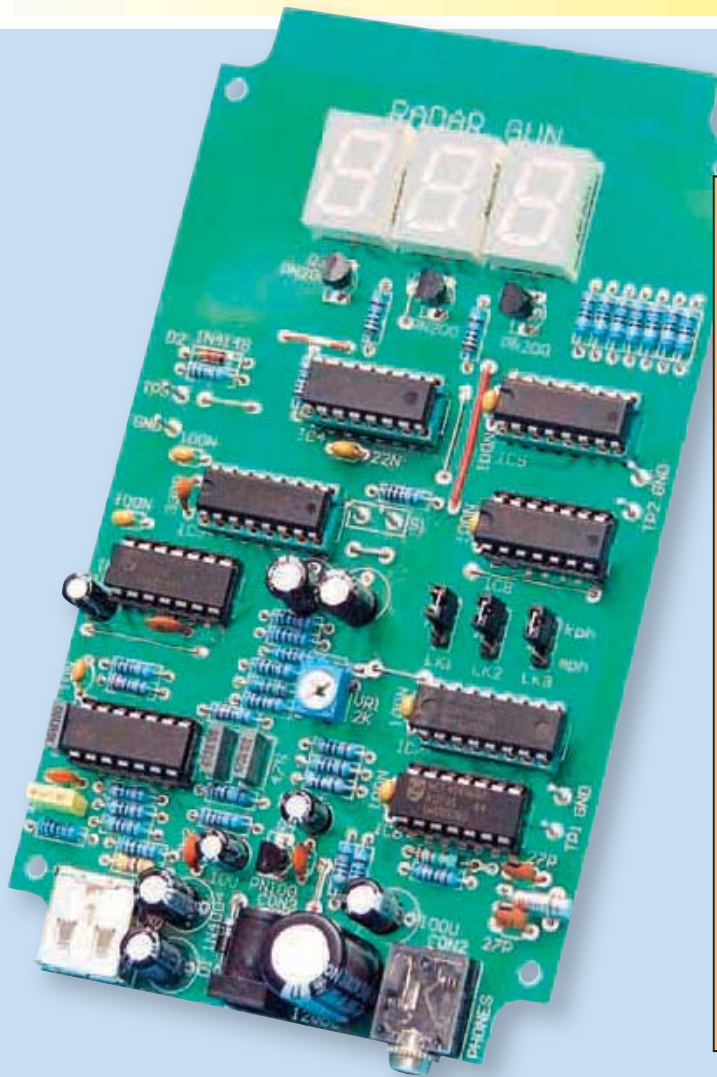

Fig.5 (right): install the parts on the counter/display board as shown here. Note that our prototype used 3-pin headers and 2-pin jumpers to program the timebase, but wire links could also be used.

to mount VR1 on the track side of the PC board, to allow for easy adjustment once the board has been fitted to the lid. Be sure to fit the correct value resistor in each location. Table 1 shows the resistor colour codes, but we also recommend that you check them using a digital multimeter, as some of the colours can be difficult to decipher.

The small ceramic, monolithic and metallised polyester capacitors can now all be mounted. These capacitors are all non-polarised, so they can be fitted either way around. Follow them with the electrolytics, which are, of course, polarised, so take care to fit them with the correct orientation.

That done, fit the 38kHz crystal (X1). As shown in Fig.5 (bottom right), this mounts on its side, with both leads bent

downwards about 2mm from its case so that they pass through the holes in the PC board. Solder its leads to the underside copper pads, then fit a small U-shaped piece of tinned copper wire over the crystal's case to secure it in position (the ends of the wire 'U-loop' are soldered to matching pads on the board).

Now for the semiconductors; begin with the two diodes, taking care to install them with the correct orientation. Also, be sure to use the 1N4004 power diode for D1 and the smaller 1N4148 signal diode for D2.

Follow these with the three 7-segment LED displays. These must all be orientated with their decimal point LEDs (which we don't use here) at the lower right. The four transistors can go in next – the PN100 device goes in the Q4

position (near the bottom of the board), while the three PN200 devices go in the Q1 to Q3 positions below the displays. Once these parts are in, install the USB, power and headphone sockets.

Finally, plug the eight ICs into their sockets, taking care to 'ground' both yourself and the PC board to earth before handling them. This is necessary because most of the ICs are CMOS devices and are vulnerable to damage from an electrostatic discharge.

Your counter/display board is now finished and can be placed aside while you assemble the microwave head board. Note that we haven't discussed the Hold switch (S1) at this stage, because it mounts on the box lid and is only connected to the display board later.

# Constructional Project

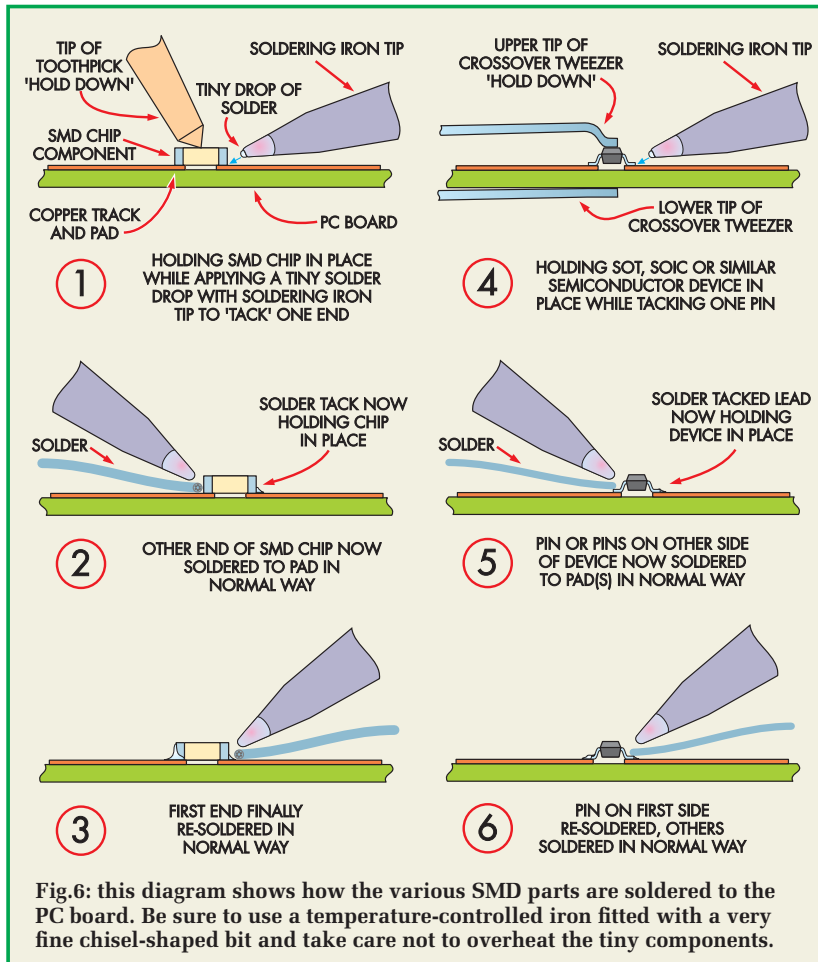

Fig.6: this diagram shows how the various SMD parts are soldered to the PC board. Be sure to use a temperature-controlled iron fitted with a very fine chisel-shaped bit and take care not to overheat the tiny components.

## Microwave head board

The microwave head printed circuit board component layout is shown in Fig.8. This board is also available from the *EPE PCB Service*, code 694.

This second board is considerably smaller than the first, but it is more challenging because about half of the components on it are small surface-mount devices. It's also double-sided, but this shouldn't cause you any problems if you use the board supplied in the kit which will have plated-through holes and solder masking on both sides.

Only one component mounts on the underside of the board – the Type A USB socket. Everything else mounts on the top of the board, because virtually all of the underside copper is used as an earthed ground plane and shield.

Before you begin fitting components to this board, examine the overlay diagram of Fig.8 to familiarise yourself with how it all goes together. That done, begin the assembly by fitting the surface-mount (SMD) parts.

To do this, you'll need a soldering iron with a very fine chisel-shaped tip, which you need to keep particularly clean. Ideally, it should also be a temperature-controlled iron, so it doesn't get too hot and damage the tiny components. In addition, you'll need a small pair of crossover tweezers to handle the SMD parts and a wooden toothpick to hold down each part while you solder it in position.

You'll also find an illuminated magnifier a big help – especially if it's on the end of a spring-loaded arm, so you can place it in just the right position above the PC board.

## Surface-mounting

Manually soldering SMD parts in place isn't all that difficult if you tackle them carefully and one at a time. Fig.6 shows how to solder both passive and active SMD parts onto a PC board.

Referring to Fig.8, you should fit the SMD parts to the head-end of the board in the following order:

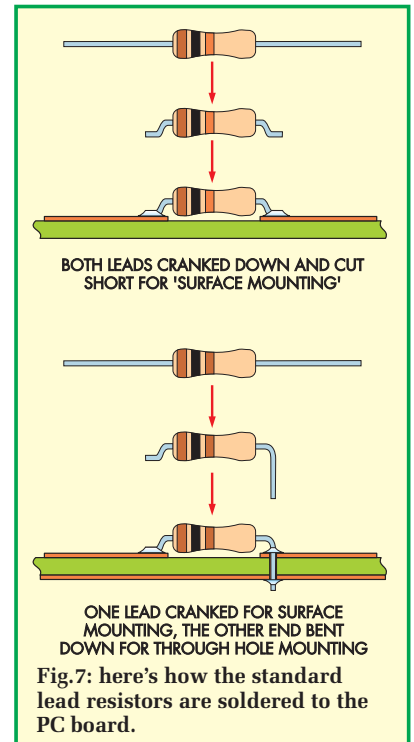

Fig.7: here's how the standard lead resistors are soldered to the PC board.

- 1) 100Ω 0805 resistor at upper right
- 2) 1nF 1206 ceramic capacitor near the top of the board, just to the left of centre
- 3) Five 10nF 1206 ceramic capacitors
- 4) Oscillator transistor Q1 (this must be orientated with its 'fatter' collector lead at upper right)
- 5) Mixer diode D1, orientated with its 'two-lead' side towards the antenna microstrip line on its right
- 6) ERA2-SM microwave amplifier chip (IC1), orientated with its locating dot and diagonal-cut end (pin 1) towards the bottom of the board
- 7) RFC1, the UHF choke, which is the largest of all the SMD devices (orientated with its pin 1 identification dot at lower right).

That completes the trickiest part of the board assembly and you should now be ready to fit the rest of the parts.

## USB connector

Begin this second phase by fitting the USB connector, which mounts on the underside of the board. It's fitted in the normal way by carefully pushing all its connection leads and mounting clips through the matching board holes, then soldering them to the pads on the top of the board.

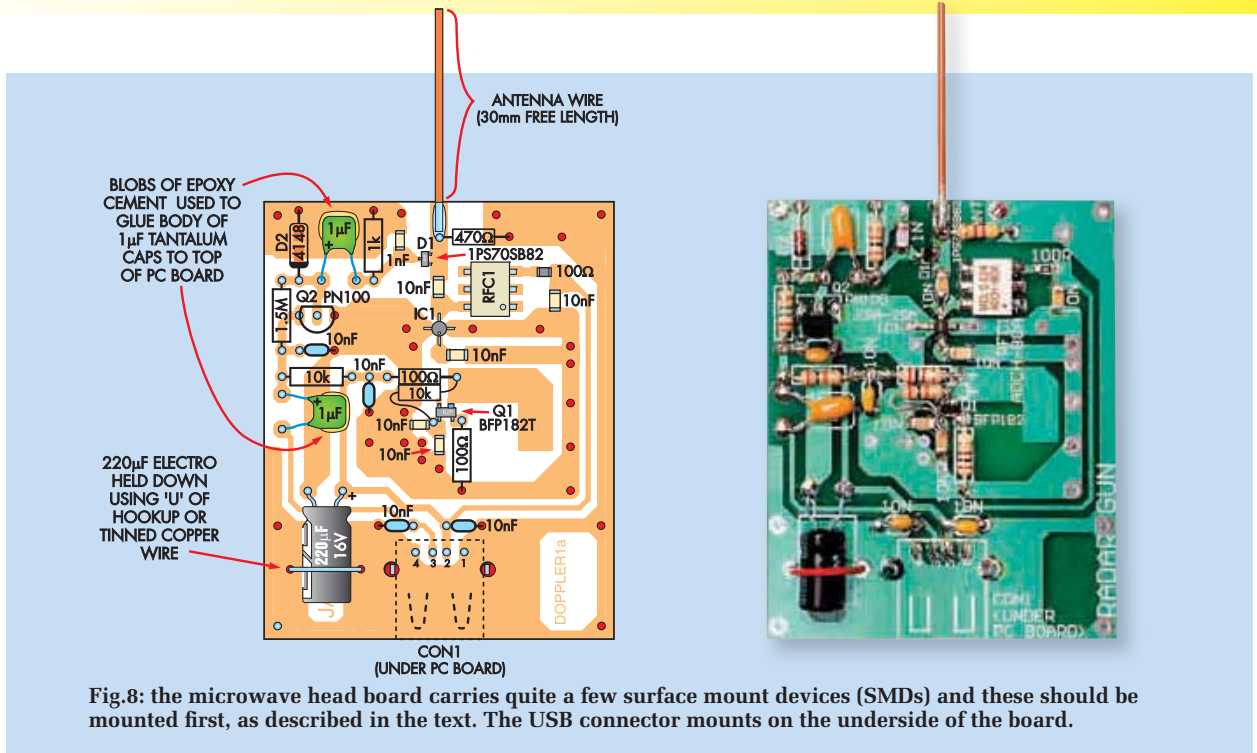

Fig.8: the microwave head board carries quite a few surface mount devices (SMDs) and these should be mounted first, as described in the text. The USB connector mounts on the underside of the board.

Next, fit the standard (axial) lead resistors, but note that most of these are mounted in a slightly unorthodox way – either with both end leads cranked down and cut short for ‘surface mounting’, or with only one lead dressed this way and the other bent down in the usual way to pass through a board hole.

Fig.7 shows how the leads are prepared and the resistor fitted to the PC board in each case.

Start with the resistors that are fitted with one end passing down through the board hole. These are: 1) the 100Ω resistor which connects the emitter of Q1 to ground; 2) the 1kΩ load resistor

for mixer diode D1; and 3) the 470Ω DC return resistor between the antenna microstrip line and ground.

In all three cases, it’s the lead at the ‘earthy’ end of the resistor which passes down through the board hole. These leads are then soldered to the copper pads on *both* sides of the board. In contrast, the ‘cranked down’ leads at the other ends of these resistors are soldered only to the copper pad on the top layer.

The remaining ‘leaded’ resistors can now be installed. Three of these have both leads cranked down as at the top of Fig.7, ie the 10kΩ collector load resistor for Q2, the 1.5MΩ bias

resistor for Q2 and the 100Ω collector resistor for Q1.

The last resistor to be mounted on the board is the 10kΩ bias resistor for transistor Q1, which is fitted in a different way again. As shown in Fig.8, this resistor is fitted alongside the 100Ω collector resistor. One lead is bent down and over before cutting it short, so that it can be soldered to the same pad on Q1’s collector line as the 100Ω resistor. The other end is then bent round in a hairpin shape and then down, so that it can be soldered to the copper pad just below the base lead for Q1, where the two 10nF SMD bypass capacitors are also connected.

**Table 1: Resistor Colour Codes**

	No.	Value	4-Band Code (1%)	5-Band Code (1%)
□	1	2.2MΩ	red red green brown	red red black yellow brown
□	1	1.5MΩ	brown green green brown	brown green black yellow brown
□	1	1MΩ	brown black green brown	brown black black yellow brown
□	1	330kΩ	orange orange yellow brown	orange orange black orange brown
□	6	100kΩ	brown black yellow brown	brown black black orange brown
□	4	47kΩ	yellow violet orange brown	yellow violet black red brown
□	2	22kΩ	red red orange brown	red red black red brown
□	6	10kΩ	brown black orange brown	brown black black red brown
□	1	6.8kΩ	blue grey red brown	blue grey black brown brown
□	2	4.7kΩ	yellow violet red brown	yellow violet black brown brown
□	4	1kΩ	brown black red brown	brown black black brown brown
□	7	680Ω	blue grey brown brown	blue grey black black brown
□	2	470Ω	yellow violet brown brown	yellow violet black black brown
□	3	100Ω	brown black brown brown	brown black black black brown
□	2	47Ω	yellow violet black brown	yellow violet black gold brown

# Constructional Project

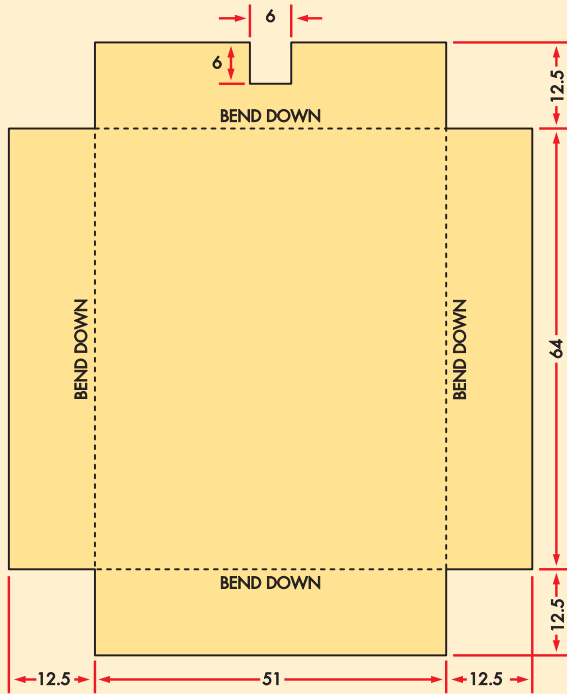

MATERIAL: 0.3mm OR 0.25mm BRASS SHEET

Fig.9: the shield box that encloses the microwave head board is made from a rectangular piece of 0.3mm or 0.25mm thick brass sheet. Cut it out as shown in this diagram and fold down the sides to form the box.

Be sure to cut this lead to length before you solder it, as it's not easy to cut off any excess afterwards.

The four 10nF standard monolithic capacitors are next on the list. These all use the same arrangement used for some of the resistors, ie one cranked lead and one lead bent down for through-hole mounting.

It's just a matter of carefully dressing their leads and cutting them to length before fitting them. The leads that pass through the board holes are again soldered on both top and bottom sides of the board.

Diode D2 goes in next and this is fitted in the same way as the resistor shown at the bottom of Fig.7. Make sure that it's the anode (A) lead that passes down through the earthing hole.

Transistor Q2, the PN100 transistor, can now be installed. This is again fitted in an unusual way: its emitter (E) lead passes down through a board hole in the normal way, while the other two leads are bent at right angles, about 4mm down from the transistor body, so that they 'sit' on the pads on the top of the board in surface mount fashion. After bending them, cut these leads off about 2mm from the bends before soldering them to their respective pads.

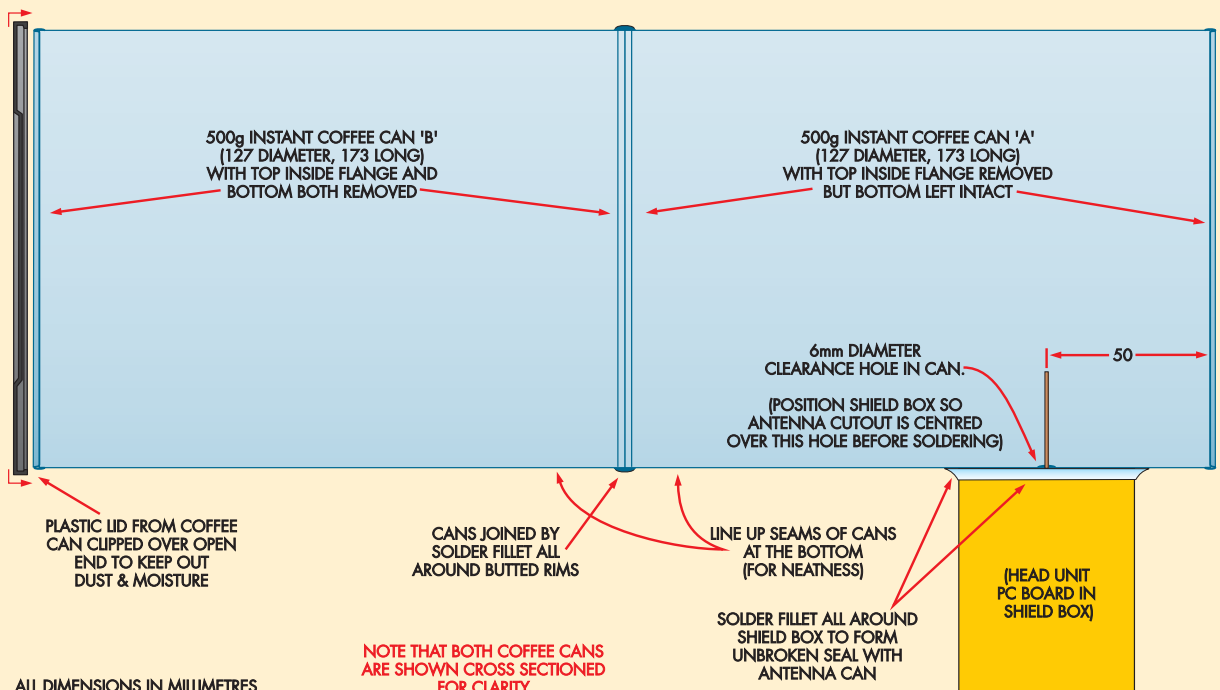

Fig.10: the antenna barrel for the microwave head unit is made from two coffee cans. It's made by first drilling a hole for the antenna in can 'A', then soldering the two coffee cans together to form the barrel (see text).

The emitter lead is soldered to the copper pads on *both* sides of the board.

The 220 $\mu$ F electrolytic capacitor mounts on its side in the lower lefthand corner of the board. Before mounting, its leads need to be bent outwards a little, then down through 90°. Its negative (-) lead then passes through a board hole in the usual way (and is soldered at both top and bottom), while its positive lead is bent horizontally again and cut short for 'surface mounting' to its pad. A 'U-shaped' loop of tinned copper wire is then installed over the electro's body, to hold it securely in position.

The two 1 $\mu$ F tantalum capacitors are also installed with their bodies flat against the PC board. In both cases, their leads are cranked downwards for 'surface mounting' on the pads below. Be sure to fit them with the correct polarity. Once they're in position, mix up a small amount of quick-setting epoxy cement to hold them securely in place – see Fig.8.

### Antenna

Your microwave head board is now just about complete. All that remains is to attach the antenna wire at the top centre of the board, see Fig.8 and photograph.

The antenna is made from a 35mm length of 1.3mm dia. enamelled copper wire, with about 4mm of enamel insulation scraped off one end. This 'scraped end' is then soldered to the rectangular pad at the top of the antenna feed line, as close to 'on-axis' as you can make it.

Finally, check the free length of the wire with a steel rule or vernier calliper, and, if necessary, trim the far end to bring the free length to exactly 30mm.

### Functional check-out

Now that your boards have both been wired up, it's time to give them a quick functional check-out. This is easily done by connecting them together via the USB cable, plugging a pair of stereo headphones into the 3.5mm jack on the counter/display board and connecting a 12V DC supply (positive to the centre pin). The latter can be a 12V bench supply or a 12V battery pack of some kind.

As soon as power is applied, the 7-segment LED displays should immediately begin showing a random count. Shortly after this, you'll also begin to hear hum in the headphones and possibly some other noises.

If all is well so far, try moving your hand back and forth near the antenna

This is the view down the antenna barrel. The 30mm-long antenna wire can be seen right at the back and sits exactly 50mm from the rear – see Fig.10. Make sure the antenna wire goes through the middle of the hole in the can and doesn't short against the metal.



wire on the microwave head board. You should hear a buzzing sound when you do this, with a pitch that depends on your hand's speed. It will be higher in pitch when your hand is moving faster and lower when it's moving more slowly. And if you watch the LED displays at the same time, they should give a higher reading for fast hand movements too.

### Troubleshooting

If your results are as we've just described, your Radar Speed Gun boards are probably working as they should. However, if there seems to be some kind of problem, or you want to make sure, you'll probably want to do some troubleshooting. Here are the things you can try:

1) With your multimeter set to DC volts, measure the voltage at the

cathode (banded) end of diode D1 on the counter/display board. It should be very close to +11.4V relative to ground (0V).

2) Check the voltage at pin 14 of IC6 – it should be very close to 11.4V

3) Measure the voltage across the 220 $\mu$ F electrolytic capacitor on the microwave head board – it should measure approximately +7.5V.

If these voltages all check out correctly, most of the circuitry is probably working correctly.

If you have an oscilloscope, you can check that the crystal oscillator on the counter/display board is working properly by looking at the waveform on test point TP1. You should find a slightly rounded square-wave with a frequency of 38kHz. Alternatively,

## Use This Device In A Responsible Manner

Be sure to use this device in a responsible manner. **In particular, DO NOT use this device to measure the speed of vehicles on a public road.**

The main reason for this is that drivers will not know what is being aimed at them, particularly as you will not be in police uniform. That in turn could cause alarm and could even cause some drivers to brake heavily or take evasive action. And if there was an accident, you might be held legally responsible in some way.

Similarly, **DO NOT** let anyone use the Radar Speed Gun in your car when travelling on public roads. This would not only prove distracting for the driver, but the microwave radiation from the unit could cause interference to other spectrum users – including the radar speed units used by traffic police.

In any case, the police will probably be able to detect the radiation from your unit and could apprehend and charge you with trying to disturb the operation of their equipment.

In short, to avoid trouble with other motorists and the 'boys in blue', use your Radar Speed Gun only on the racetrack, drag strip or in some other private area.



## Constructional Project

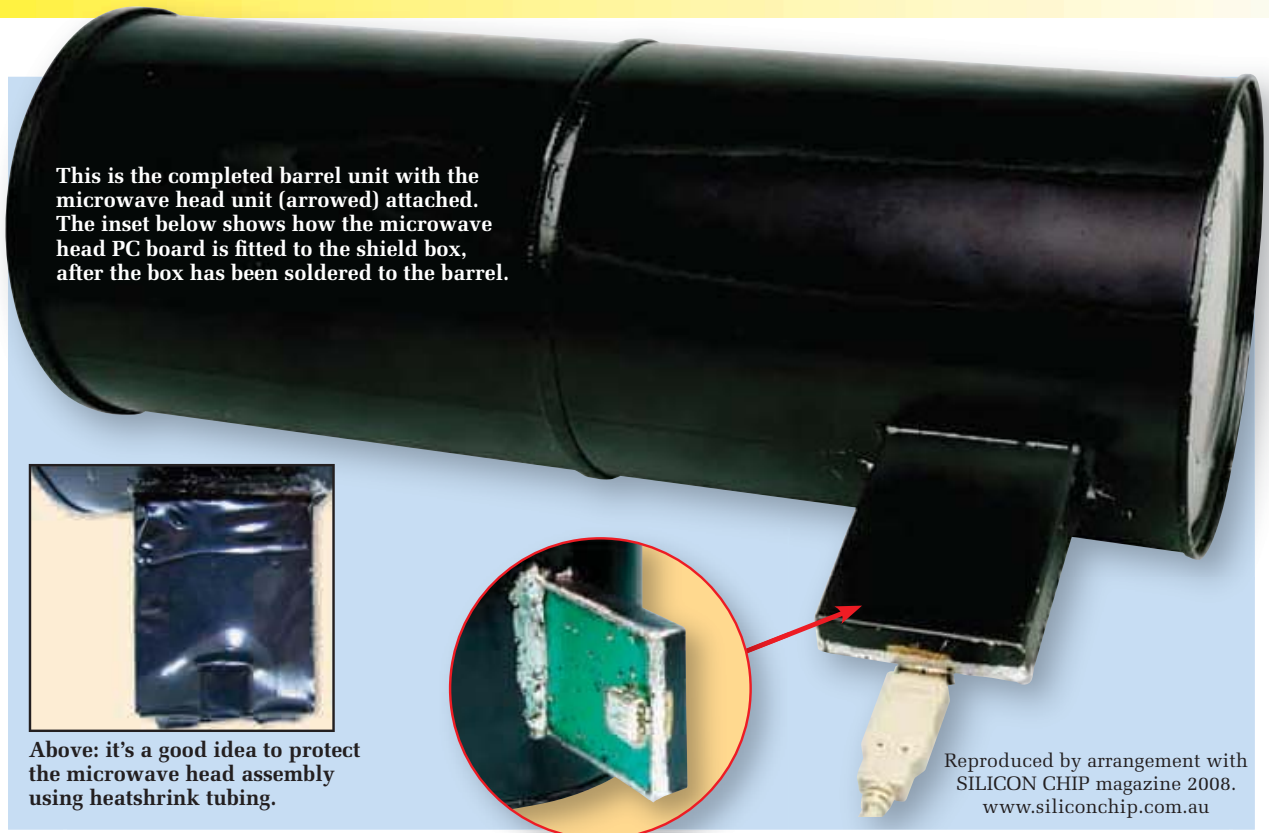

This is the completed barrel unit with the microwave head unit (arrowed) attached. The inset below shows how the microwave head PC board is fitted to the shield box, after the box has been soldered to the barrel.



Above: it's a good idea to protect the microwave head assembly using heatshrink tubing.

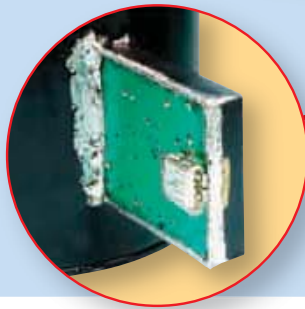

Reproduced by arrangement with SILICON CHIP magazine 2008. [www.siliconchip.com.au](http://www.siliconchip.com.au)

if you have a frequency counter, it should show the same frequency.

Now transfer your scope probe to TP2. Here you should find a train of fairly narrow positive-going pulses, with a peak-to-peak amplitude of about 11.5V and a frequency of 9.0778Hz if links LK1 to LK3 are set for *km/h* readout. Alternatively, this frequency should be 14.6103Hz if you have cut the tracks and fitted the three links for *mph* readout.

These frequencies can also be checked with a frequency counter if you have one.

If all is well so far, transfer your scope probe to TP3 and again move your hand back and forth near the microwave antenna. You should see a train of narrow, negative-going pulses, again about 11.5V peak-to-peak. These pulses will only be about 300µs wide and the frequency will depend on the speed that your hand is moving.

If your unit passes these tests, you're ready for the next stage in the assembly – making the head-end shield box.

### Making the shield box

A rectangular piece of 0.3mm or 0.25mm thick brass sheet is used to make the shield box which encloses the microwave head board – see Fig.9.

The brass sheet is first cut to a size of 89 × 76mm, after which a 12.5 × 12.5mm square cutout is made in each corner. A 6 × 6mm square is then cut from the centre of one of the narrow ends, as shown. This is the clearance hole for the antenna, when it's all assembled.

When the cutouts have all been made and any burrs filed off, the four sides are then bent down by 90°, corresponding to the dashed lines shown in Fig.9. Make sure that the ends of the sides meet cleanly at each corner. This forms the basic shield box, with the head-end board itself forming the 'top' when it's fitted.

To finish the box off, use a high-power soldering iron to run a small fillet of solder down inside each corner. This will ensure that the corners are properly sealed, for both physical strength and shielding. The box can then be placed aside while you make up the radar gun's antenna barrel.

### Making the antenna barrel

To make the antenna barrel you'll need two clean tin cans, each measuring 127mm in diameter and 173mm long. These can be easily obtained from your local supermarket, because they are the kind used for 500g cans of low-cost instant coffee.

That means that you'll end up with one kilogram of instant coffee as well as the two cans. If you transfer the coffee into some jars, you'll have plenty of instant coffee for quite a while!

Note that the cans usually come complete with clip-on plastic lids, so be sure to keep at least one of these lids to use as a dust cover over the open end of the finished barrel. Alternatively, you can use the plastic top from a bulk CD container as a dust cap.

Once the two cans are emptied, washed and dried, you can proceed to turn them into your antenna barrel. Both need to have their inner top flange removed and this is easily done using a can opener of the type which cuts around the inside of the rim using a sharp wheel. The same opener is then used to remove the bottom of one of the cans, which subsequently becomes the front half of the barrel, ie, can 'B' in Fig.9.

Don't remove the bottom from the other can though (can 'A').

Next, drill a 4mm hole in the side seam of can 'A', with its centre as close as you can make it to a point 50mm up from the inside bottom of this can. The easiest way to do this is to first measure the distance inside the can from bottom to top. That done, move

your rule to the outside and mark a point on the side seam that is down from the top rim by the total distance less 50mm. Finally, centre-punch this point and drill the 4mm hole.

After the hole is drilled, carefully enlarge it to 6mm diameter using a tapered reamer. You should then remove any remaining burrs using a jeweller's needle file or similar.

Next, you should remove the lacquer from the outside of this can around this 6mm hole by rubbing it with steel wool soaked in methylated spirit. You should remove the lacquer from a rectangular area about 30mm up and down from the hole (along the seam) and about 12mm on either side, giving a cleaned area of about 60 × 24mm. This is where the shield box will later be soldered to the can.

### Heavy-duty

You can now use a heavy-duty soldering iron to solder the bottom rim of can 'B' to the top rim of can 'A'. This involves butting them together and running a smooth solder fillet right around the mating joint. Note that it's also a good idea to line up their side seams as well, as this gives a neater end result.

Once you're happy that the two cans are cleanly and securely joined together to form the barrel, the next step is to solder the shield box (empty at this stage) to the side seam 'underside' of can 'A'. Be sure to align the 6 × 6mm end cutout in the shield with the 6mm barrel hole. Again the idea is to run a neat but strong solder fillet around all three outer edges of the box sides. Another solder fillet can then be run along the edge on either side of the 6 × 6mm cutout.

### Head-to-head

Your barrel and shield box assembly are now ready for the final and most delicate stage – that of soldering the head-end PC board assembly into the shield box.

Just before you do this, make sure that the top inside edges of the shield box sides and outer end are clean and free from oil or grease. If you wish, you can tin around these edges but don't leave more than a very thin layer of solder, otherwise you won't be able to slip the PC board into the box for final soldering.

Now take the head-end PC board assembly and turn it over so that the component side is underneath and with the antenna wire at the top. That done, angle the board downwards and pass the antenna wire through the 6mm hole and

The counter/display unit fits inside a standard plastic case.

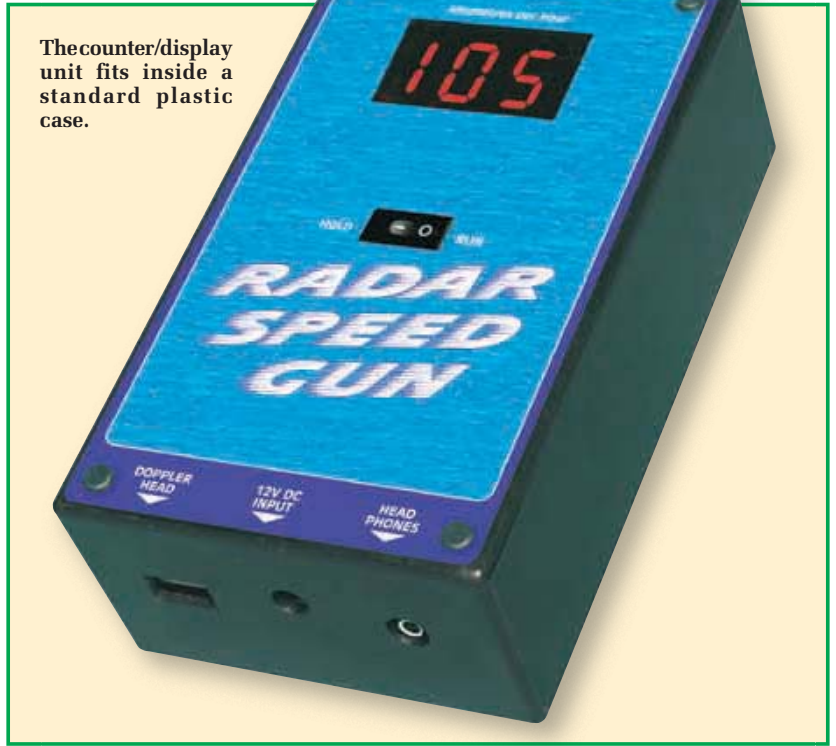

into the barrel, until the top end of the board meets the end of the shield box.

Once it's there, lower the complete board assembly into the shield box, so that its copper groundplane is just below the box lip. It should now stay in this position while you attach it securely inside the box by running a small fillet of solder around the edges.

Here's a useful tip: you'll find this job a lot easier if you position straight lengths of 0.5mm diameter tinned copper wire inside each edge before you begin soldering. This wire 'encourages' the solder to bond across between the PC board copper and the brass inner sides of the box.

It won't be easy to cover the top of the antenna wire hole in the barrel using solder alone. The answer to this is to place a small piece of copper shim over the remaining hole, bent by about 80° in the centre so it forms a patch to seal the hole (it overlaps both the can metal and the PC board's ground plane copper). Solder the edges of this copper patch to both the barrel and the PC board to complete the shielding around the antenna.

This will ensure that all of the microwave energy passes into the antenna, to be radiated from the barrel.

The antenna barrel assembly should now be complete, although you might

want to give it a coat of paint to hide its coffee can heritage. If you decide to do this, carefully place some layers of masking tape (or gaffer tape) all around the USB socket on the back of the shield box, to stop paint from entering the socket. You can then apply the paint to the outside of both the barrel and the shield box, using either a spray can or brush.

Our prototype was sprayed with black automotive lacquer. You may also wish to protect the microwave head board assembly with some heatshrink tubing – see photo on page 46.

### Final assembly

Before mounting the board, you need to fit a small rectangle of red Perspex behind a cutout in the lid, to form a viewing window. You can secure it by using a drop or two of super glue or contact adhesive around the edges. A rough guide to the required box cutouts/holes can be seen in the display box photograph.

That done, the PC board can now be mounted on the inside of the lid on four M3 × 25mm tapped metal spacers. Secure it using M3 × 6mm countersink head screws at the lid ends and round-head M3 × 6mm screws at the board ends.

You also need to fit the Hold/Run switch S1 into its rectangular cutout in

### Watch out for spurious readings

Because the Doppler audio signals produced in the Radar Gun's microwave head are quite low in level, they need a great deal of amplification (between 2000 and 22,000 times) in the counter/display unit to bring them up to a level which can be converted into pulses for reliable counting. This large amount of amplification makes the Radar Speed Gun susceptible to interference from electrical noise and AC hum, which tend to cause spurious readings when it is not aimed at a moving object.

For example, if the amplifier picks up a 50Hz hum, this will give a spurious reading of 11km/h. Similarly, 100Hz hum will give a spurious reading of 22km/h, while impulse noise from electric motors will give different spurious readings.

You'll also find that if you aim the Radar Speed Gun at fluorescent lamps, this too will give spurious readings – but for another reason. The discharge plasma in fluorescent tubes pulses on and off at double the mains frequency, ie at 100Hz in the case of tubes running from 230V, 50Hz. Because some of the Radar Speed Gun's microwave energy is reflected back from the plasma in bursts modulated at this rate, the unit's mixer produces a 'false' Doppler frequency of 100Hz. As a result, you'll not only hear a loud 100Hz hum in the headphones, but also get a spurious speed reading of 22km/h.

In practice, these spurious signals are not really a problem, since they are swamped by the much stronger return signals being received when you aim the unit at a real moving target. Just don't be alarmed if your unit displays 11km/h or 22km/h (or some other figure) while indoors or near a source of electrical interference – that's perfectly normal.

end of the straight, so that you can aim directly at it as it comes towards you.

### Correction factor

If you can't do this and have to make your measurements at an angle of 25° or 30° to the vehicle's path, you can still work out its speed fairly accurately simply by dividing the readings by a correction factor. This correction factor is simply the cosine of the measuring angle.

For example, if you're making measurements at an angle of 25°, the correction factor will be  $\cos(25^\circ) = 0.906$ . So if you get a speed reading of 110km/h, the vehicle's true speed will be  $(110/0.906)$ , or very close to 121km/h. Get the idea?

Another thing that can affect the accuracy is movement of the microwave head itself. For the most accurate readings, the antenna barrel should be held as steady as possible. If you find that too difficult, you may want to fit the antenna barrel with a 'U-shaped' metal bracket, so it can be mounted on a camera tripod. **EPE**

the centre of the front panel. It pushes through from the front – but make sure that you orientate it so that the '1' on its rocker actuator is towards the left. Note that you may need to 'square up' the switch cutout if it has rounded edges.

That done, turn the panel over and attach a short length of tinned copper wire to each of the connection lugs on the back of the switch. Attach them securely, by looping the end of each wire through the hole in its lug and then compressing the loop with your pliers before soldering. This will ensure that the joints don't come apart when the wires are soldered to the PC board pads. Alternatively, you can use a short length of figure-8 wire to connect the switch to the PC board.

Next, set VR1 (which adjusts the gain from 20-220) to mid-range. The board can then be lowered into position on the spacers, with the switch wires passing through their respective holes in the centre. Secure it using the roundhead M3 × 6mm machine screws, then solder the switch wires and fit the lid in position.

Your Radar Speed Gun is now ready for its final check-out.

### Final check-out

The Doppler Radar Speed Gun is simple to use. All you need to do is

connect the two parts of the system together using the USB cable, connect a 12V battery pack (or some other source of 12V DC) and plug in a pair of stereo headphones (if you have them).

Within about 20 seconds of power being applied, you should begin hearing sounds in the headphones, indicating that the Doppler signal processing circuitry has sprung into life and stabilised. After that, it's simply a matter of pointing the antenna barrel at a suitable moving target and holding it steady for a few seconds so that the frequency counter's readout can stabilise with the speed reading.

You'll also find that the sound in the headphones helps a lot in directing the beam at the vehicle and holding it in the right position. You'll soon get used to identifying the 'whooshing' sound produced by the Doppler signals.

Once the speed of the vehicle is being displayed on the counter, you can operate the Hold switch to freeze the reading.

Remember that for the highest reading accuracy, the axis of the Radar Speed Gun's barrel should be aligned as closely as possible with the path of the moving target. Of course, this won't always be possible because you can't stand directly in a vehicle's path! However, if the vehicle is on a racetrack, you might be able to position yourself at the

ANDRE LAMOITHE'S  
**XGAMESTATION**  
LEARN STEP-BY-STEP HOW TO DESIGN  
AND BUILD YOUR OWN VIDEO GAME CONSOLE!  
Design inspired by the Atari 800/2600,  
Sinclair ZX Spectrum, Apple II & Commodore 64!

Complete Package eBook Integrated IDE

SK52 CPU  
80 MIPS!

OPEN SOURCE!

**FEATURES:**

- Great for Hobbyists AND Students!
- Complete Software Development Kit!
- eBook on Designing the XGS Console!
- Parallax SX-Key Compatible!
- Fully Assembled XGS Micro Edition Unit!
- The Fun Way to Learn Embedded Systems!

PAL & NTSC  
COMPATIBLE!

WWW.XGAMESTATION.COM  
SUPPORT@NURVE.NET PH: 2.266.2399(USA)

# MAGENTA

## ELECTRONICS LTD

135 Hunter Street Burton on Trent Staffs DE14 2ST  
Tel: 44 (0)1283 565435 Fax: 44 (0)1283 546932

**Chips, Parts  
& Kits for  
EPE Projects**

Programmed PICs and chips for most EPE projects.  
Check our website or 'phone for prices.  
We have supplied kits for EPE\* projects for almost 30 years!!  
(\* & Everyday Electronics)

### 20W Stereo Amp.

Wide band Low distortion 11W /channel Stereo 20W Mono. True (rms) Real Power

Short Circuit & Overheat Protected. Needs 8 to 18V supply.

(Kit: inc. all parts & heatsink for stereo or mono)



Latest Technology - Stable, Reliable, high performance

**KIT 914- £11.90**

### Top Kits.

ICEbreaker PIC16F877 in - circuit emulator - Kit 900.... £34.99

1KV/500V Insulation Tester Inc. drilled case -Kit 848.. £32.95

Pipe Descaler - High Power with led monitor - Kit 868..£22.95

Ultrasonic PEsT Scarer random 32k pulses Kit867..£19.99

P-I Metal Detector Micro based design - sensitive Kit847..£63.95

**MAGENTA Bat Detectors**  
Our original famous KIT detector Kit 861...£37.99 & See the new built MkIIb and MKIII on the web.

All Prices Include VAT, Add £3.00 P&P per order, or £7.99 for next day. Chqs. P.O. & most major cards accepted. Mail Order Only.

**MAGENTA**

www.magenta2000.co.uk  
sales@magenta2000.co.uk

## SHERWOOD ELECTRONICS

Buy 10 x £1 Special Packs and choose another one FREE

SP1	15 x 5mm Red LEDs	SP137	4 x W005 1-5A bridge rectifiers
SP2	12 x 5mm Green LEDs	SP138	20 x 2.2/63V radial elect. caps.
SP3	12 x 5mm Yellow LEDs	SP142	2 x CMOS 4017
SP5	25 x 5mm 1 part LED clips	SP143	5 Pairs min. crocodile clips (Red & Black)
SP6	15 x 3mm Red LEDs	SP144	5 Pairs min. crocodile clips (assorted colours)
SP7	12 x 3mm Green LEDs	SP146	10 x 2N3704 transistors
SP8	10 x 3mm Yellow LEDs	SP147	5 x Stripboard 9 strips x 25 holes
SP9	25 x 3mm 1 part LED clips	SP151	4 x 8mm Red LEDs
SP10	100 x 1N4148 diodes	SP152	4 x 8mm Green LEDs
SP11	30 x 1N4001 diodes	SP153	4 x 8mm Yellow LEDs
SP12	30 x 1N4002 diodes	SP154	15 x BC548B transistors
SP18	20 x BC182B transistors	SP155	3 x Stripboard, 14 strips x 27 holes
SP20	20 x BC184B transistors	SP160	10 x 2N3904 transistors
SP22	20 x BC549B transistors	SP161	10 x 2N3906 transistors
SP23	4 x CMOS 4001	SP164	2 x C106D thyristors
SP24	4 x 555 timers	SP165	2 x LF351 Op Amps
SP25	4 x 741 Op Amps	SP166	20 x 1N4003 diodes
SP26	4 x CMOS 4011	SP167	5 x BC107 transistors
SP28	4 x CMOS 4013	SP168	5 x BC108 transistors
SP29	4 x CMOS 4081	SP172	4 x Standard slide switches
SP33	20 x 1N914 diodes	SP173	10 x 220/25V radial elect. caps
SP34	25 x 10/25V radial elect. caps.	SP174	20 x 22/25V radial elect. caps.
SP36	12 x 100/35V radial elect. caps.	SP175	20 x 1/63V radial elect. caps.
SP37	15 x 47/25V radial elect. caps.	SP177	10 x 1A 20mm quick blow fuses
SP38	10 x 470/16V radial elect. caps.	SP178	10 x 2A 20mm quick blow fuses
SP39	15 x BC237 transistors	SP181	5 x Phono plugs - asstd colours
SP40	20 x Mixed transistors	SP182	20 x 4/763V radial elect. caps.
SP41	200 x Mixed 0-25W C.F. resistors	SP183	20 x BC547B transistors
SP42	5 x Min. PB switches	SP186	8 x 1M horizontal trim pots
SP47	4 x 5 metres stranded-core wire	SP189	4 x 5 metres solid-core wire
SP49	20 x 8-pin DIL sockets	SP192	3 x BC107 transistors
SP102	15 x 14-pin DIL sockets	SP195	3 x 10mm Yellow LEDs
SP103	15 x 16-pin DIL sockets	SP197	6 x 20-pin DIL sockets
SP104	15 x BC557B transistors	SP198	5 x 24-pin DIL sockets
SP109	4 x CMOS 4093	SP199	5 x 2-5mm mono jack plugs
SP112	3 x 10mm Red LEDs	SP200	5 x 2-5mm mono jack sockets
SP115	3 x 10mm Green LEDs		
SP116	2 x CMOS 4047		
SP124	20 x Assorted ceramic disc caps		
SP128	100 x Mixed 0-5W C.F. resistors		
SP131	2 x TL071 Op Amps		
SP133	20 x 1N4004 diodes		
SP134	15 x 1N4007 diodes		
SP135	5 x Miniature slide switches		
SP136	3 x BFY50 transistors		

Catalogue available £1 inc. P&P or FREE with first order.  
P&P £1.75 per order. NO VAT  
Cheques and Postal Orders to:  
**SHERWOOD ELECTRONICS,**  
10 NEWSTEAD STREET,  
MANSFIELD, NOTTS. NG19 6JJ

RESISTOR PACKS - C.Film

RP3	5 each value - total 365 0-25W	£3.40
RP7	10 each value - total 730 0-25W	£4.65
RP10	1000 popular values 0-25W	£6.60
RP4	5 each value - total 305 0-5W	£4.20
RP8	10 each value - total 610 0-5W	£6.85
RP11	1000 popular values 0-5W	£8.95

## Measure, Test & Control

PC based measure & control units. Analogue/Digital IO, data loggers from £49

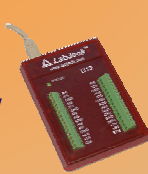

Budget Test Equipment Scopes Multimeters Function Generators from £99



Robot and Controller Kits - Micros, LCD, Relay boards Free Software From £29



PC Weather Stations Wind speed, direction, temp, humidity, rainfall Free software From £59



Learn more at [www.audon.co.uk](http://www.audon.co.uk)

**AUDON** Electronics

www.audon.co.uk | +44 (0)115 925 8412 | Fax +44 (0)115 925 9757



## CRICKLEWOOD ELECTRONICS

Established 1981



Frustrated with your supplier? Visit our component packed website for a vast range of parts - old and new, many unavailable elsewhere!  
[www.cricklewoodelectronics.com](http://www.cricklewoodelectronics.com)

1000's OF PRICES REDUCED!

Alternatively phone us on 020 8452 0161 with your requirements.



Visit our Shop, Call or Buy online at:  
[www.cricklewoodelectronics.com](http://www.cricklewoodelectronics.com)

**020 8452 0161** Visit our shop at:  
40-42 Cricklewood Broadway  
London NW2 3ET



# Recycle It!



BY JULIAN EDGAR

## An automatic stopwatch timer

**Do you need to automatically record equipment running time? This stopwatch timer starts when power is applied to a low-voltage (12V) circuit and automatically stops when the power is switched off. When power is again applied, the stopwatch continues to count from where it was last stopped.**

**T**HE AUTOMATIC stopwatch timer is a cinch to build, and resetting the count is as easy as pushing a button. And by using a snap-action thermostat (salvaged, of course!) it's even possible to automatically measure how long a temperature is above or below a set-point – ideal for environmental, solar heating and machinery monitoring.

Since it uses salvaged parts, the complete project should cost you only a few pounds. Let's see what's involved.

### The components

You'll need an old digital watch with a stopwatch function, two relays (one

a double-throw design), a capacitor and a pushbutton switch. Oh yes, and something to mount the components on! We used a small piece of pre-punched matrix board (unclad) and that was literally the only component that we had to buy new!

It's quite likely that you already have a digital stopwatch tucked away in a drawer – as fashions change, lots of people buy new watches even when the old one is still working fine.

If you have to buy a new one, shop around at discount stores – it shouldn't be too hard to find a cheap watch that includes a stopwatch function for a few

pounds. The unit shown here came from a watch I'd not worn in years – in fact, until I went looking, I'd forgotten I even had it.

Relays can be found in a huge amount of discarded electrical equipment. The ones used here are quality Omron designs that were salvaged from an old radio transmitter that had been sent to the tip. Although they use 24V coils, they work fine in this application, which is based around a 12V supply.

Note that if you want to use the timer to monitor even lower voltage equipment, you'll need lower voltage relays; eg, 5V. Don't use this project to monitor voltage rails above about 15V DC, otherwise you will damage the circuit components.

What about the 220 $\mu$ F 25V electrolytic capacitor used here? Well, again they're everywhere in older electrical equipment – just take a look!

Finally, the momentary pushbutton switch was salvaged from behind the front control panel of a VCR. All older VCRs with click-action pushbutton controls have this type of switch buried behind the faceplate.

### How it works

Fig.1 shows the circuit diagram for the Automatic Stopwatch Timer (the circuit was designed by John Clarke). Let's look at Relay 1 first – its coil is wired in parallel with whatever device we're monitoring – so when the device is on, so is Relay 1. This closes the normally open (NO) and common (Pole) connection, feeding power to the coil of Relay 2 via the capacitor.

The 220 $\mu$ F capacitor is wired in series with Relay 2's coil, so Relay 2 will pull-in only for as long as it takes the capacitor to charge. In this case, using the relays and capacitor specified, that takes about 0.1s.

Relay 2's NO and Pole connections are wired to the contacts that normally start and stop the stopwatch. So when

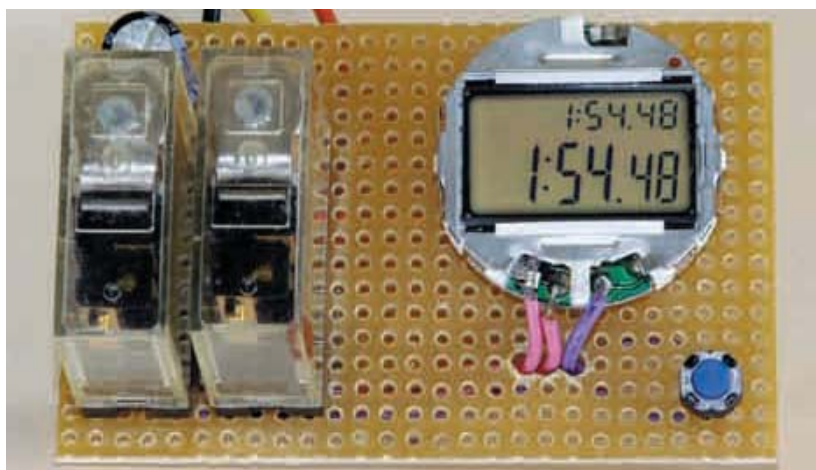

**This digital stopwatch timer will automatically measure how long low voltage equipment is running, making a cumulative count until reset. Most of the parts can be salvaged for nothing.**

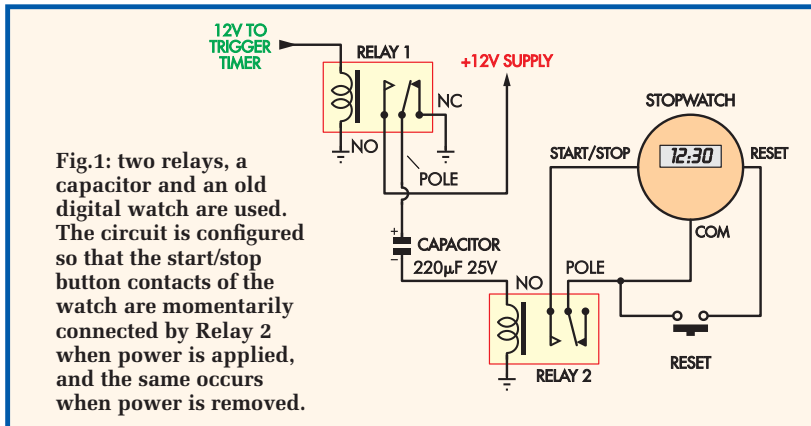

power is applied to Relay 1's coil, Relay 2 is momentarily pulled in, and the stopwatch is triggered. That's the starting pulse – now, what about the stopping pulse?

When power is removed from Relay 1's coil (ie, the monitored device is switched off), Relay 1's NC (normally closed) and Pole terminals are connected. This immediately provides a path for the capacitor to discharge through the coil of Relay 2, so again momentarily pulling it in. Bingo! – we now have a switch-off or stop pulse.

The reset button simply bridges the watch's original reset contacts.

## Building it

The first step is to remove the rear of the watch, carefully pull out the workings and inspect the start/stop and reset buttons.

Normally, a single common is connected to a PC-board pad to start and stop the count, and to another pad to reset the timer.

You need to solder a wire to the common and then two others to the start/stop and reset pads.

As might be expected, it's easier to do this in some watches than others. Note too, that in some watches, the common comprises a 'springy' stainless steel strip, which it is impossible to solder. If this is the case, bend the strip over and crimp it to the wire.

Once you have the three wires coming from the watch, check that you can start, stop and reset the stopwatch.

After that, it's just a case of following the circuit diagram. Make sure that you

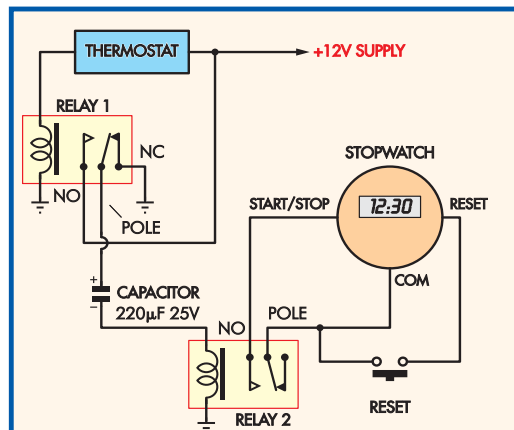

work out which are the normally open (NO), normally closed (NC) and common (Pole) relay contacts. Often, there



Any old digital watch that has a stopwatch function is potentially suitable for this project. However, the ease with which wires can be soldered to the switch pads varies from watch to watch. When selecting the watch you should also take note of the maximum time the stopwatch display can show.

is a small diagram on the relay itself, or you can use the continuity function of a multimeter to check the contact behaviour.

Take care when wiring in the capacitor, as this device is polarised. Its negative side is usually shown by a line of '-' symbols near one of its leads.

## Using It

Testing the unit is easy. First, connect the +12V and earth (0V) leads to the power supply, then connect the 12V trigger wire to +12V. The timer should start running and continue for as long as this wire is connected to the +12V rail.

Now disconnect this wire – the timer should immediately stop. Finally, press the reset button and – well, you can guess what should happen!

Note that if you just brush the trigger wire against the +12V rail, the relay contacts may 'bounce'.

This can result in the timer getting out of sequence – that is, running when it should be stopped and stopped when it should be running. If this happens, manually bridge the start/stop terminals to return it to the correct operating sequence.

If you find that both relays click, but the device isn't working as it should, try increasing the value of the capacitor. If the relays have clear covers, it's interesting to watch Relay 2 quickly pulsing when the watch starts and stops.

When running, the prototype draws about 50mA. So, if you are monitoring a battery-operated device, this should be considered.

Reproduced by arrangement with SILICON CHIP magazine 2008. [www.siliconchip.com.au](http://www.siliconchip.com.au)





# Practically Speaking

Robert Penfold looks at the Techniques of Actually Doing it!

HAVE no idea how many electronic gadgets have been constructed by electronics enthusiasts over the years, but I would have thought that by now it must be well into the millions. No doubt a fair percentage of these were close copies of the prototype design, or were built from kits and were therefore clones of the original. However, most people tend to 'do their own thing' to some extent when building electronic projects, and it is likely that the majority of home-constructed electronic devices differ significantly from the original design.

Sometimes changes from the original design are not simply a matter of 'doing your own thing', but are enforced due to problems in obtaining exactly the right components. This is where those of limited experience are at a big disadvantage in comparison to 'old hands', and component substitution should be avoided unless you are reasonably sure that the alternative component is suitable for the job. Determining the suitability of substitute parts often requires some specialist knowledge, but there are some types of substitution that can be carried out successfully without an in-depth knowledge of electronics.

## Disappearing act

There are some components where it is highly unlikely that any alternative type will be available. These days many electronic construction projects have unusual applications, and are based on one or more components that are highly specialised in nature. If one of these 'specials' becomes unavailable, then the project concerned becomes unviable. Integrated circuits and other semiconductor components are the most common causes of this 'now you see it – now you don't' problem, but it can occur with any specialised component.

It is for this reason that readers are frequently advised not to start buying components for a project until they are sure that everything required is still readily available. This avoids the frustration and expense of gathering together an almost complete set of components for a project that can never be finished.

A problem of this type is unlikely to occur with a project that was published recently, but it is as well to 'play safe' as there is a small chance that it could happen. At the other extreme, a project from long ago is almost certain to use at least a few components that are no longer available.

## Semiconductors

Although there are usually no substitutes for specialised semiconductor components, it is often possible to find a suitable alternative with the more general purpose types. Many designs from the past use transistors that are no longer available as such, but which are available under different type numbers.

However, bear in mind that the type number is dissimilar because the device has a different case and (or) leadout configuration. An alternative transistor might fit into the component layout without difficulty, but it will probably require some forming of the leads in order to make it fit. Try to avoid bending the leads right next to the case of the component as this is a good way of causing them to break off.

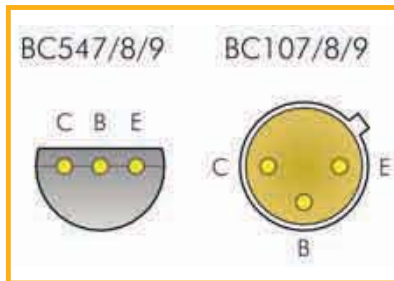

Fig.1. The plastic BC547/8/9 transistors are effectively the old BC107/8/9 series in a plastic case rather than a metal type. They should always act as suitable substitutes for the original devices, and have a similar leadout configuration

The BC107/8/9 series of transistors were the most popular in the early days of silicon devices, and these components can still be obtained today, albeit at relatively high prices. The original components were in metal cases, but these were replaced by plastic types that were cheaper to manufacture.

There are several 'plastic' versions of the BC107/8/9 series, but the BC547/8/9 series is probably the most popular. The leadout diagrams for these two series of transistors are shown in Fig.1, and as is the convention, these are base views. In other words, they depict the components with the leads pointing towards the viewer, which is the opposite of the convention for integrated circuits.

The leadout configurations of the two series of devices are not the same, but they are quite similar, making it easy to use one in place of the other. The BC547/8/9 can be used in place of

other plastic versions of the BC107/8/9, such as the BC237/8/9, but the leadout configurations will usually be different, so care has to be taken in order to get the substitute devices connected correctly. Electronic component catalogues are a useful source of transistor leadout data, and it is possible to obtain the data sheet for practically any semiconductor by simply entering the type number and 'data sheet' into a search engine.

Remember that there are two distinctly different types of bipolar transistor, which are the *NPN* and *PNP* varieties. The important difference between the two is that they require supplies of opposite polarity, so they are definitely not interchangeable. Using the wrong type is unlikely to result in any damage, but there is no chance of the circuit working correctly until the correct type is used.

The BC557/8/9 series are effectively the *PNP* versions of the BC547/8/9 series, and they are good substitutes for earlier devices such as the BC177/8/9 series. Clearly, care has to be taken when choosing substitutes, making sure that *NPN* devices are only replaced with *NPN* types, and that *PNP* devices are only replaced with the *PNP* variety.

## Semiconductor groupies

Some transistors are available in three versions, with the suffix letters 'A', 'B', and 'C' being used to identify them. The silicon chips are the same for each version, and the only difference is that during the testing procedure they are placed in high, medium, and low gain groups. Thus, the BC549C is the high gain version of the BC549. Matters are complicated slightly by the availability of devices in gain groups and plain versions that have no suffix.

It should be perfectly all right to use any version in cases where no particular gain group is specified in a components list. For example, even a humble BC549A should suffice where a plain BC549 is called for. It is probably best to use the correct version where a particular gain group is specified, although in practice a 'C' device would probably work perfectly well in place of lower gain types.

Transistors are often used as simple switches and amplifiers where the exact characteristics of the device are not critical, and virtually any transistor of the right structure (*NPN* or *PNP*) will suffice. There are exceptions though, where a high voltage, high power, or high frequency device is required, and a small general purpose transistor will not work, and could be short-lived.

It is possible to find suitable alternatives for many of the more highly specified transistors, but the choice is likely to be limited and greater care has to be exercised. There is plenty of information about semiconductor substitutes on the Internet, but much of this is theoretical rather than 'tried and tested'. With the more specialised transistors it is best to use the genuine article wherever possible.

## Op amps

Many operational amplifiers use the same pin-out configuration as the original 741C device, and have some degree of compatibility with the 741C and each other. This is not to say that they are fully interchangeable. Modern operational amplifiers offer improvements over the original design, but each type offers a different enhancement or enhancements. It is no use using a wide bandwidth, low-noise type in a circuit that requires a precision DC device or one that will work at low voltages.

A good general-purpose operational amplifier such as an LF351N or TLO81CN will actually work quite happily in many circuits, and can sometimes be used instead of a 741C to provide an old design with improved performance. However, in many circuits they will give poor performance or will fail completely. Trying a substitute device is unlikely to risk damaging anything, but unless you know what you are doing it is quite likely that it will not be successful.

## One way

Diodes and rectifiers are the most simple of semiconductors, and their basic action is to allow a current to flow in one direction but to block any flow in the opposite direction. There is no 'hard and fast' division between diodes and rectifiers, but the 'diode' name is generally used for a component that will handle small signals, whereas a rectifier is a higher power device, typically used in a power supply. For such a basic component there is a surprising variety of types available.

The range of rectifiers on offer has been rationalised somewhat in recent years, and is more restricted than in the past. Many electronic projects use components from the 1N400\* series of rectifiers, and with these the higher the number in the last digit of the type number, the higher the maximum operating voltage of the device.

At first it made sense to have several versions of the component, because the higher voltage types were more expensive to produce than the lower voltage components. However, the price differential eroded with time as manufacturing processes improved, and now many suppliers only offer a reduced range. In some cases only the 1N4007 is on offer, which is the one with the highest operating potential (1000 volts).

For once, this reduction in choice is of no practical importance. The 1N4007 can be used as a substitute for

any of the other rectifiers in the 1N400\* range. I suppose it could actually be considered an improvement, possibly offering slightly better reliability than the specified type.

Of course, it is not acceptable to use a lower voltage type instead of a higher voltage device, such as using a 1N4002 instead of a 1N4006. Doing so would almost certainly cause the circuit to fail and could even be dangerous.

Diodes exist in three main types, which are the silicon, germanium, and Schottky varieties. Practical experience suggests that either a 1N914 or 1N4148 diode will always work, regardless of the particular silicon diode specified by the designer. They will certainly act as suitable replacements for the OA200 that is sometimes used in older designs.

Most germanium semiconductors are now obsolete, and have been so for decades, but germanium diodes are still favoured for some applications because they have a lower forward voltage drop in comparison to silicon types. Few types of germanium diode are still available, but it is still possible to obtain the OA90 and OA91. The OA91 can be used as a substitute for most other germanium diodes, including the AA119, which is specified for some older designs.

When using germanium diodes it



*Fig.2. If a diode looks as though it is tiny, fragile and in a glass encapsulation, then it probably is. Any flexing of a lead near the casing can result in damage, as in this example*

should be borne in mind that they are not as tough as most modern components. The cases are often made from glass, which is quite brittle and easily damaged, and tends to break if the leads are bent close to where they emerge from the case. Germanium semiconductors are also less tolerant of heat than the silicon variety, and must be soldered into place quite quickly. Using a heat-shunt to absorb some of the heat from the iron reduces the risk of damage.

Schottky diodes and rectifiers have a lower forward voltage drop than silicon types, and can generally operate at higher speeds. They are used in demanding applications such as switch-mode power supplies.

The only suitable substitute for a Schottky diode or rectifier is another Schottky component that has an equal or superior specification to the original part. A circuit might actually work using a silicon type instead, but the efficiency would be impaired, giving reduced performance and possibly increasing the loading on other parts of the circuit.

This could lead to the failure of the circuit, and might even be dangerous.

## Making a switch

It is possible to obtain all sorts of weird and wonderful switches, but the current range is rather different to that available a few years ago. With the more basic types of switch there should be no real problems. This is a subject that has been covered recently, and it will not be considered further here.

Biased switches, where the switch returns to its original setting when released by the user, can cause problems. Any type of biased switch that has the right contact arrangement should do, so it will not matter if a toggle switch is used instead of a push-button switch, or vice versa. In fact, the circuit should work using a non-biased switch, but it will probably be slightly less convenient in use.

Finding a suitable replacement for one of the more elaborate switches of the past can be problematic. Sometimes something like an ordinary 4-way 3-pole rotary switch has the wherewithal to handle the task. Banks of interlocking push-button switches used to provide a means of mimicking other types of complex switch, as did the rotary switches where you could

build a custom switch from custom parts. Both types were expensive, and neither seem to be available anymore. Consequently, there might be no satisfactory substitute for a complex switch that is no longer available.

## Passives

Resistors should not cause any buying difficulties, since a wide range of sizes and types is still available. There can be slight problems with potentiometers, because the slider type can be difficult to find these days. However, they are still available from some suppliers. Of course, an ordinary rotary type is a suitable substitute from the electrical point of view, but rotary controls are not well suited to some applications, such as audio mixer circuits.

On the face of it, a capacitor substitute should be perfectly adequate provided it has a suitably high maximum voltage rating, a tight enough tolerance rating, and the right value. In practice, it is not as simple as that, and capacitors have other characteristics that can be important. For example, parameters such as good high frequency performance and a value that changes little with variations in temperature can be important.

In non-critical applications, a circuit should work well enough using polyester capacitors, polycarbonate types, or any other type of capacitor that has the right value and basic ratings. Using a cheap substitute for a more specialised type of capacitor such as a silvered mica or tantalum type will at best produce poor performance, and could easily prevent the circuit from functioning at all.



# Breadboarding Projects

by Dr Malcolm Plant

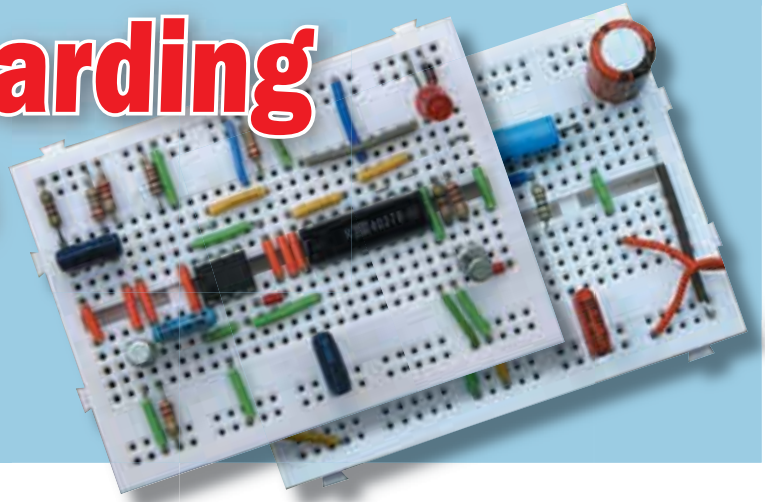

## A beginner's guide to simple, solder-free circuit prototyping Part 4: Clap Switch and Low-Budget Intercom

This month, in Part 4, we present a couple of more interesting circuits for building on breadboard – a clap switch and a simple intercom.

### Project 7: Clap switch

THE circuit shown in Fig.4.1 is designed to switch on a relay, RLA, when microphone MIC1, senses a single clap of the hands, and switch off the relay on the next hand-clap, and so on.

#### Components needed...

**Integrated circuits, IC1 and IC2:** type 555 timer (IC1); type 4027 CMOS dual JK master/slave flip-flop (IC2)

**Transistors, TR1 and TR2:** both type BC108 or similar in a TO18 style package

**Electret microphone insert, MIC1:** sub- or ultra-miniature omni-directional

**Light emitting diode, LED1:** suggest red

**Diode, D1:** type 1N4148 signal diode

**Relay, RLA:** low voltage 6V type, single-pole changeover contacts

**Resistors, R1 to R8:** values 4.7k $\Omega$  (R1,R7), 2.2M $\Omega$  (R2), 220k $\Omega$  (R3,R6), 2.2k $\Omega$  (R4), 10k $\Omega$  (R5) and 220 $\Omega$  (R8), all 0.25W carbon film

**Capacitors, C1 to C3:** values 10nF polyester (C1), 100nF polyester (C2, C3)

**Switch, S1 (On/Off):** single-pole, single-throw (SPST)

**Battery, B1:** 9V and connecting leads

**Protobloc and wire links**

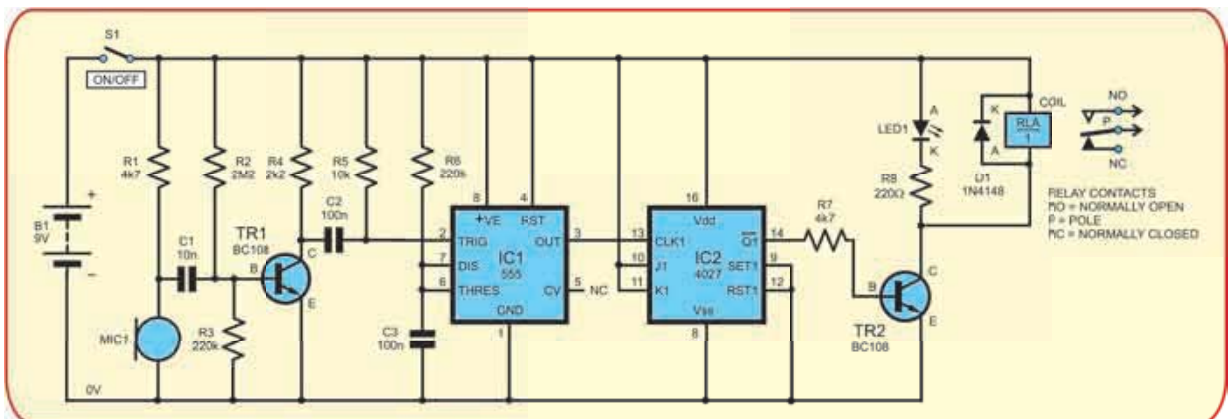

Fig.4.1: Complete circuit diagram for the Clap Switch

## Component Info

IC1, type 555 timer IC



PIN 1

Viewed from the top, an indented dot and a 'half-moon' shape at one end indicates pin one. The pins are numbered anticlockwise ending at pin 8 opposite pin 1.

IC2, type 4027 JK flip-flop



PIN 1

Viewed from above, an indented dot and a 'half-moon' shape at one end indicates pin one. Once pin 1 has been identified pins are numbered 1 to 16 going anticlockwise ending up at pin 16 opposite pin 1.

TR1 and TR2, type BC108 NPN transistor



Seen from below, the emitter lead is next to the small metal tag. Clockwise from the emitter are the base, and collector leads.



MIC 1, electret microphone

You need to solder short lengths of 0.6mm diameter insulated wire to the solder pads. One pad is connected to the case of the microphone, so make sure this lead is connected to 0V.



RLA, relay 6V energizing voltage.

This has single-pole changeover switching contacts for switching on and off a separate circuit from the electronic one.

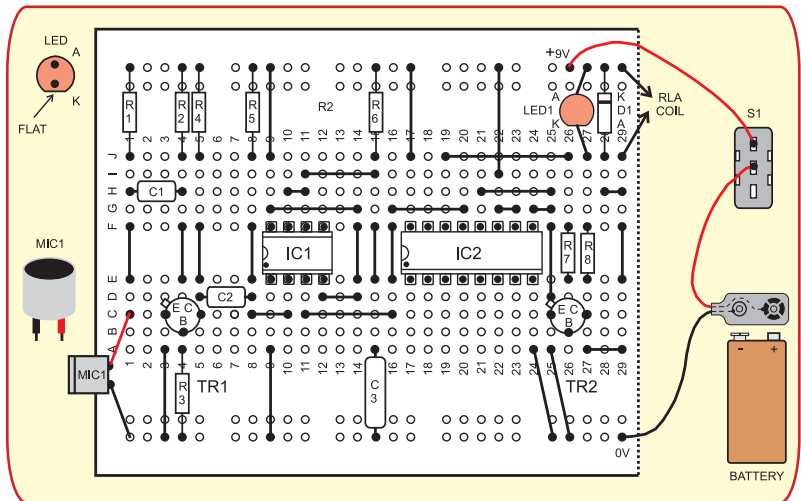

Fig.4.2: Assembly of the Clap Switch on the Protobloc breadboard

## How it works

The circuit comprises four main building blocks. The first is centred on NPN transistor TR1, which switches on when the sound of a handclap is sensed by the microphone. Current flowing through the collector (C) and emitter (E) terminals of TR1 causes a fall in the voltage at its collector, which triggers the second building block.

The second building block is based on IC1, a 555 timer wired as a monostable. On receiving the sharply falling voltage from the collector of TR1, IC1 produces a short pulse of about 20ms, which is fed into the clock terminal of IC2, a JK flip-flop, which makes up the third building block.

If IC2 pin 14, the  $\bar{Q}$  output, is logic low, transistor TR2 is off and the relay is not energized. The pulse from the monostable changes the state of the flip-flop and the  $\bar{Q}$  pin goes logic high, switching on TR2, hence energising the relay. Thus TR2 switches on or off, energising or de-energising the relay on subsequent claps, each clap 'toggling' the flip-flop. LED1 is optional, but is useful in monitoring the change of the  $\bar{Q}$  output of the flip-flop.

The relay connected in parallel with resistor R8 and LED1 is energized when LED1 lights and its normally-open contact is used to switch external circuits on and off. **Note that this circuit must not be used to control mains-powered circuits.**

## Breadboard

The Protobloc component layout for the Clap Switch is shown in Fig. 4.2.

When soldering the leads to the electret microphone insert connecting pads be as quick as possible as it does not take kindly to excessive heat. Note that one pad is also connected to the case of the mic, so make sure this lead is connected to the board 0V line.

## Notes

- Do not use the relay to control power from the mains supply. If you want to control mains-operated devices you should seek the help of a qualified electrician.

- Use the Circuit Tester described in Project 1 to identify the base leads of TR1 and TR2 to confirm that they are both NPN transistors.

- Once assembled on Protobloc, you will find that LED1 is either on or off, but a sharp clap of the hands will change this by either switching the relay on (LED1 lit) or off (LED1 out).

- Diode D1 is used to protect the semiconductors, ie the transistors and integrated circuits, from possible damage by the sharp surge of voltage known as back EMF, which is generated as the relay switches off.

- No adjustments are necessary to the circuit, but you might like to fashion a small paper cup, a curved reflector, and fit it around the microphone to enhance the directional sensitivity of the circuit to the sound of a clap.

**LOW-BUDGET INTERCOM**

## Project 8: Low-Budget Intercom

**T**HE central component in this Intercom project is an integrated circuit designed for audio amplification, type LM386. It is shown as IC1 in Fig.4.3. The circuit shows that it needs few additional components to do its job of amplifying audio signals.

The internal voltage gain is set at 200 by capacitor C2, connected between pins 1 and 8. Two low-power loudspeakers, LS1 and LS2, act as microphone or speaker depending on the position of the double-pole, double-throw reversing switch, S2.

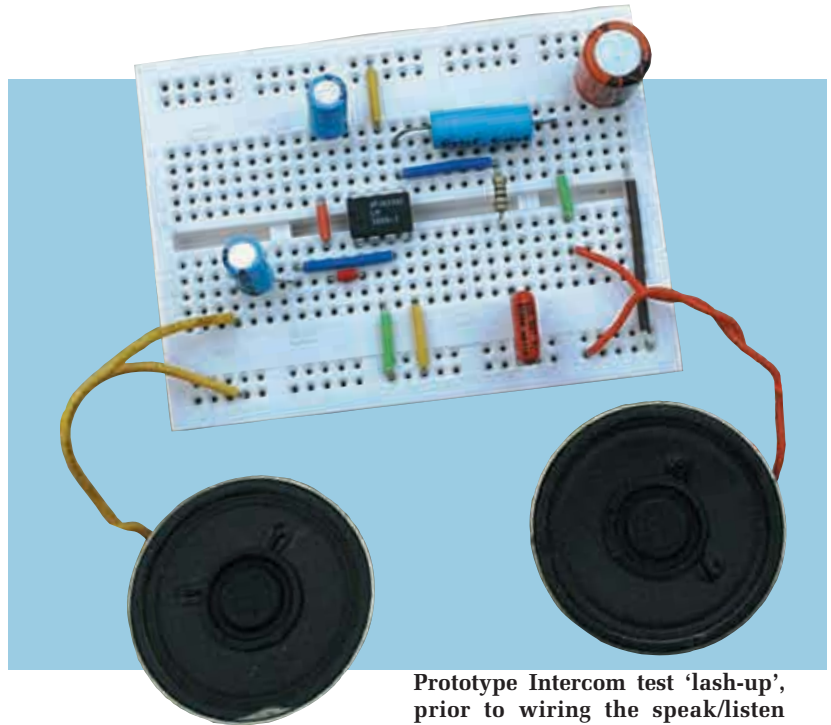

Prototype Intercom test 'lash-up', prior to wiring the speak/listen master switch S2

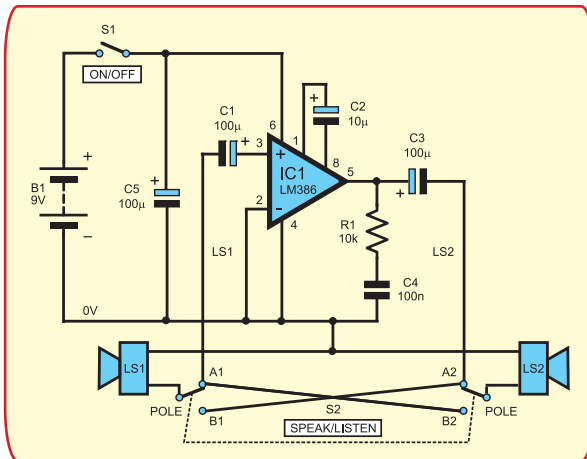

Fig.4.3: Low-Budget Intercom circuit diagram

### Components needed...

- Integrated circuit, IC1:** type LM386 low power audio amplifier
- Loudspeakers, LS1 and LS2:** miniature 8Ω or 16Ω impedance
- Capacitors, C1 to C5:** values 100μF radial electrolytic 16V (C1, C5), 100μF axial elect. 16V (C3), 10μF radial elect. 16V (C2) and 100nF polyester (C4)
- Resistor, R1:** value 10kΩ 0.25W carbon film
- Switch, S1 (On/Off):** single-pole, single-throw (SPST)
- Switch, S2 (Speak/Listen):** double-pole, double-throw (DPDT), toggle or slider
- Battery, B1:** 9V and connecting leads
- Protobloc and wire links**

### Construction brief

#### To ensure trouble-free assembly, you should try and follow these basic guide lines

Always use single-core 0.6mm diameter plastic-sleeved wire for wire links, not thicker. The ends of the wire should be stripped of plastic for about 8mm. The use of thicker wire can permanently damage the springy sockets underneath each hole.

Never use stranded wire; it can fray and catch in the sockets, or a strand can break off and cause unwanted connections below the surface of the breadboard.

It is very important to make sure that the bared ends of link wires and component leads are straight before inserting them into the breadboard. Kinks in the wire will catch in the springy clip below the socket and damage it if you have to tug to release the wire from the holes.

Make sure that the arrangement of components and wire links is tidy, with components snugly fitting close to the surface of the Protobloc. This usually means providing more link wires than is perhaps necessary, so as to avoid having wires going every-which-way across the board.

Never connect the battery leads to the top and bottom rails of the breadboard until you have carefully checked that all the component connections correspond to those on the circuit diagram.

Some components, such as switches and relays, do not have appropriate wire leads for insertion into the Protobloc. If you have access to a soldering iron, solder short lengths of single-core 0.6mm diameter plastic-sleeved wire to the terminals of these components.

## Component Info

IC1, type LM386 audio amplifier



← pin 1

This has 8 pins. Viewed from above, an indented dot and 'half-moon' shape at one end indicates pin one. Once pin 1 has been identified, pins are numbered 1 to 8 going anticlockwise, ending up at pin 8 opposite pin 1.

Electrolytic capacitors C1, C2, C3 and C5



These are polarized and must be inserted the right way round. Both axial and radial types are shown on the Protobloc.

LS1 and LS2, Loudspeakers



The two wires to each loudspeaker can be connected to the circuit either way round. Each speaker will need two 0.6mm plastic covered wires attached to its terminals; for one speaker these are much longer than the other

S2, double-pole, double-throw (can be toggle or slider type)



Wire its six terminals so that it acts as a two-way switch – see Fig.4.4

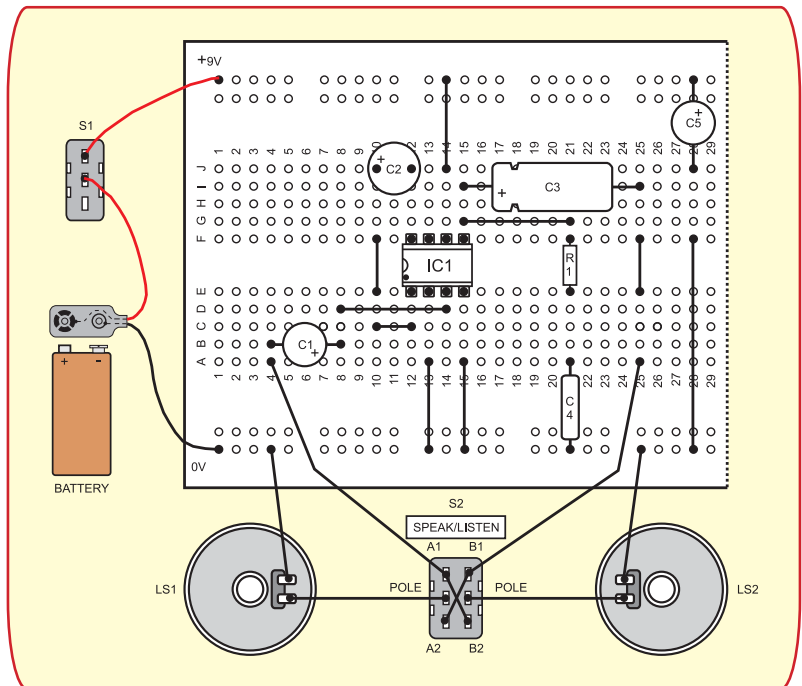

Fig.4.4: Low-Budget Intercom Protobloc breadboard component layout and wiring to off-board components

## Speak/Listen

One person has access to S2 as a 'master switch' so that he or she can decide who is to 'speak' or 'listen', depending on how the switch is 'thrown'.

This two-way switching is achieved as follows: when S2 is moved to position A1/A2, LS1 acts as a microphone and LS2 as a speaker. When S2 is moved to position B1/B2, LS2 acts as a microphone and LS1 as a speaker. Moving coil loudspeakers, in which a coil moves in a magnetic field, will convert sound waves into electrical energy, ie act as a microphone, as well as converting electrical energy into sound waves in the speaker mode.

## Breadboard

The Protobloc component layout for the Low-Budget Intercom is shown in Fig. 4.4. Electrolytic capacitors C1 to C3 must be inserted on the board with their positive (+) leads positioned as indicated in Fig.4.4. Capacitor C4 is a non-polarized type and can be inserted either way round.

The connections to S2 are also shown in Fig.4.4, which require wires to be soldered to the switch terminals for insertion into the breadboard.

## Notes

- Note that capacitors C1,C2, C3 and C5 are polarized, so you need to connect their positive terminals as shown.
- The master switch, S2, can be positioned at either end of the intercom loop.
- Switch S1 is not needed in the Protobloc assembly, but in a permanent circuit it could be replaced by a push-to-make, release-to-break switch to conserve battery use.

## PROJECTS TO COME

- Frost Alert
- Simple Die
- Bat Detector
- Ultrasonic Remote Control
- Motion Detector
- Lightning Detector
- AM Radio
- Sound Meter
- Moisture Monitor Mk 2
- Festive Lights

# Ingenuity Unlimited

Our regular round-up of readers' own circuits

## WIN A PICO PC-BASED OSCILLOSCOPE WORTH £799

- 200MHz Analogue Bandwidth Dual Channel Storage Oscilloscope
- Spectrum Analyser
- Frequency Meter
- Multimeter
- USB Interface.

If you have a novel circuit idea which would be of use to other readers then a Pico Technology PC-based oscilloscope could be yours.

After every 20 published IU circuits, Pico Technology will be awarding a PicoScope 3206 digital storage oscilloscope for the best IU submission. In addition a PicoScope 2105 Handheld 'Scope worth £199 will be presented to the runner up.

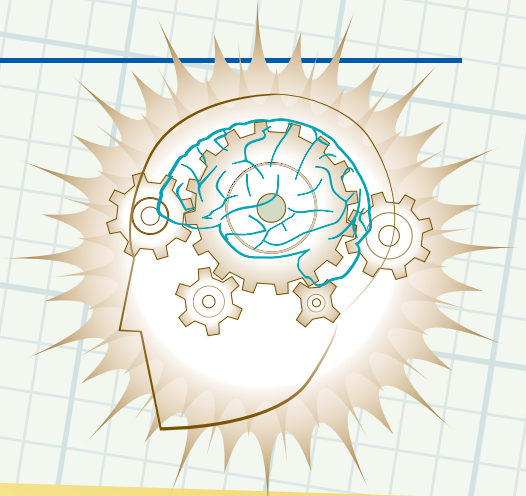
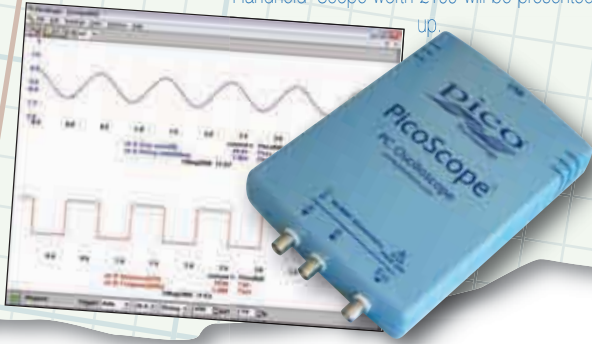

We pay between £10 and £50 for all material published, depending on length and technical merit. We're looking for novel applications and circuit designs, not simply mechanical, electrical or software ideas. Ideas must be the reader's own work and **must not have been published or submitted for publication elsewhere**.

The circuits shown have NOT been proven by us. **Ingenuity Unlimited** is open to ALL abilities, but items for consideration in this column should be typed or word-processed, with a brief circuit description (between 100 and 500 words maximum) and include a full circuit diagram showing all component values. **Please draw all circuit schematics as clearly as possible.** Send your circuit ideas to: Ingenuity Unlimited, Wimborne Publishing Ltd., Sequoia House, 398a Ringwood Road, Ferndown, Dorset BH22 9AU. Email: [editorial@epemag.wimborne.co.uk](mailto:editorial@epemag.wimborne.co.uk)

Your ideas could earn you some cash and a prize!

## Tuner Control – Digital Tuning

The circuit diagram shown in Fig.1 was originally designed to tune an FM receiver using touch switches for 'frequency up/down' rather than a mechanical rotary potentiometer. The circuit is based on the use of digital potentiometers and has a wide application where a voltage controlled function is required with good resolution and noiseless operation.

### Digital potentiometers

The circuit uses two digitally controlled potentiometers type X9C103 (IC4 and IC5). They have an end-point resistance of 10kΩ between pins  $V_h$  and  $V_l$  and the 'wiper' output at  $V_w$  can be set to one of 100 taps by selecting the chip-on pin  $\overline{CS}$  and applying clocking pulses to the INC pin. The U/D pin sets the direction.

The digital potentiometers are 5V devices and are used to provide 'Coarse' and 'Fine' control. The 'Coarse' control input operates IC4 and provides 100 steps of 100mV set by resistor R5, while the 'Fine' control input operates IC5 and provides 100 superimposed steps of 1mV set by resistor R6, which is 100 times larger.

For this circuit an output span of 10V was required with an output of 2V when pin  $V_w$  is at 5V and 12V when  $V_w$  is at 0V since op amp IC6b inverts. The scale is set by IC6b whose gain is set by the feedback resistor R9 and the 'zero' output by the bias voltage on the non-inverting input.

Op amp IC6a provides a quiet 5V reference voltage for the potentiometer and amplifier bias. The op amp used is a 'rail-to-rail' output type, but only because a 12V output was required from a

12V supply. Any common op amp will do, provided that the supply voltage is adequate to accommodate the maximum output voltage.

### Control switches

The centre-off control switches S1 and S2 operate simple gating logic to control the potentiometers and to gate a 25Hz clock to increment the 'Coarse' control and a faster 100Hz clock to increment the 'Fine' control, which would have been unnecessarily slow. The clock frequency is not important but causes the full output span to be swept in about four seconds. IC1c and divider IC7 provide the simple clock source.

The output voltage is given by the expression:

$$V_{out} = V_b \times (1 + 1.01k) - 0.01k \times V_{ref} \times \frac{N_c}{(N_c + 0.01N_f)}$$

where:

- $V_b$  is the bias voltage at IC6b pin 5
- k is the ratio of R9/R5
- $V_{ref}$  is 5V
- $N_c$  and  $N_f$  are the number of clock pulses sent to the INC input pins of IC4 and IC5.

**INGENUITY  
UNLIMITED**  
BE INTERACTIVE

IU is your forum, where you can offer other readers the benefit of your Ingenuity. Share those ideas, earn some cash and possibly a prize.



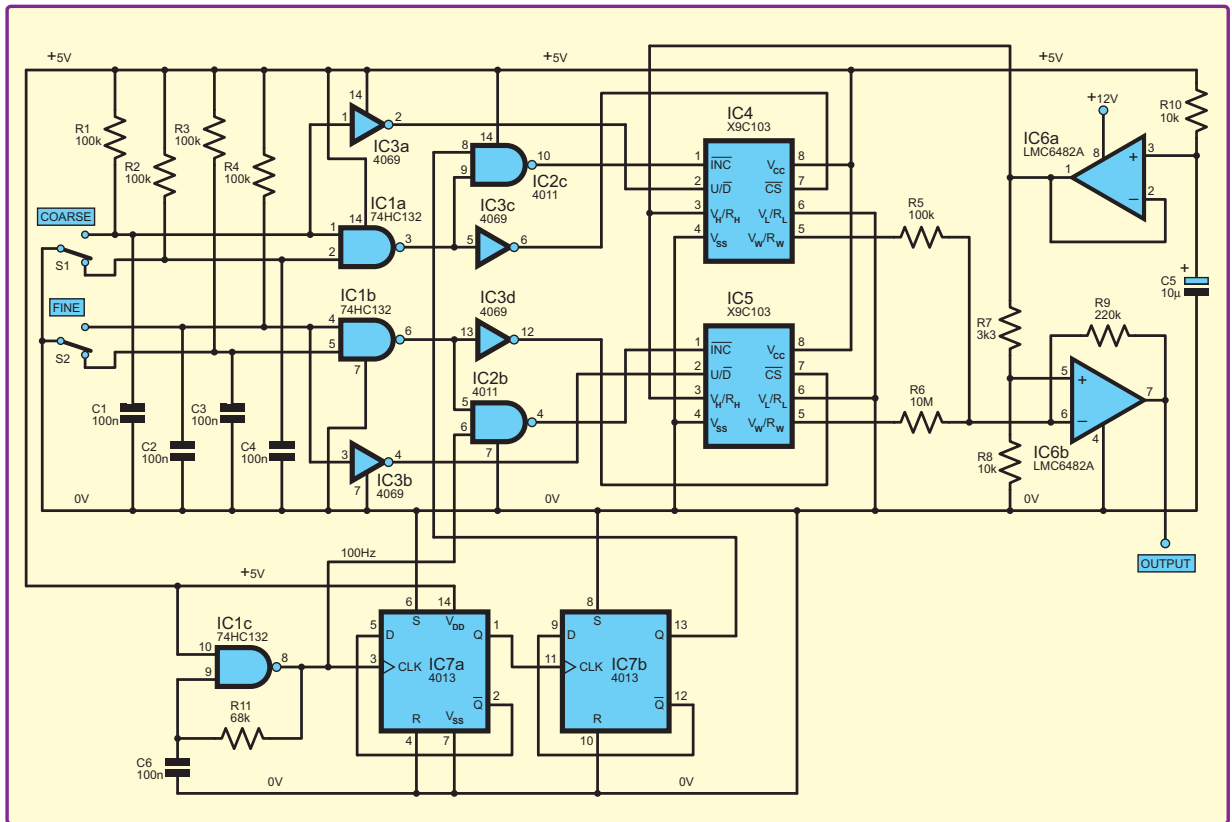

Set  $N_c$  and  $N_f$  to zero for maximum  $V_{out}$  (since the op amp is inverting) and set  $N_c$  and  $N_f$  to 100 for minimum  $V_{out}$ .

This gives  $V_b = \Delta V / [1 + (\Delta V / V_{ref})]$  and  $k = \Delta V / 1.01 \times V_{ref}$  where  $\Delta V = (V_{out}(\max) - V_{out}(\min))$ .

M. Forbes, London

Fig.1. Circuit diagram for the Tuner Control

# [www.stewart-of-reading.co.uk](http://www.stewart-of-reading.co.uk)

## OSCILLOSCOPES ON EXTRA SPECIAL OFFER (For Limited Period Only)

### TEKTRONIX

465 Dual Trace 100MHz Delay Sweep	£75
465B Dual Trace 100MHz Delay Sweep	£95
466 Dual Trace 100MHz Analogue Storage	£75
468 Dual Trace 100MHz Delay Sweep Digital Storage	£125
475 Dual Trace 200MHz Delay Sweep	£110
2214 4 Ch. 20MHz Analogue 1 MS/S	£95
2215A Dual Trace 60MHz Delay Sweep Dual TB	£95
2220 Dual Trace 60MHz Digital Storage, Cursors	£125
2225 Dual Trace 50MHz	£95
2230 Dual Trace 100MHz Digital Storage, Cursors	£195
2235 Dual Trace 100MHz Dual TB	£150
2235A Dual Trace 100MHz Dual TB	£175
2236 Dual Trace 100MHz Dual TB with Counter Timer & DMM	£175
2236A Dual Trace 100MHz Dual TB with Counter Timer & DMM	£195
2245A 4 Ch. 100MHz Dual TB Delay Sweep, Cursors	£195
2430 Dual Trace 150MHz 100 MS/S	£250
2445 4 Ch. 150MHz Delay Sweep, Cursors etc	£195
2445A 4 Ch. 150MHz Delay Sweep, Cursors etc	£225
2445B 4 Ch. 150MHz Delay Sweep, Cursors etc	£250
2445B With DMM 4 Ch, 150MHz Delay Sweep, Cursors	£250
2465 4 Ch. 300MHz Delay Sweep, Cursors etc	£300



2465A 4 Ch. 350MHz Delay Sweep, Cursors etc	£400
2465B 4 Ch. 400MHz Delay Sweep, Cursors etc	£500
2465B Rack Mount 4 Ch. 400MHz Delay Sweep, Cursors etc	£400
2467 4 Ch. 350MHz Delay Sweep, Cursors etc	£400
TAS 465 Dual Trace 100MHz Delay, Cursors	£195
TAS 485 4 Ch. 200MHz Delay, Cursors	£275

### HP

54501A Digitising 2+2 Ch 100MHz 10 MS/S	£150
54502A Digitising 2 Ch. 400MHz 400 MS/S	£250
54600A Dual Trace 100MHz 20 MS/S	£195
54600B Dual Trace 100MHz 20 MS/S	£225

### PHILLIPS

PM3052 Rack Mount Dual Trace 60MHz	£75
PM3055 2+1 Ch. 60MHz dual TB/Delay, Autoset	£95
PM3065 2+1 Ch. 100MHz dual TB/Delay, Autoset	£125
PM3084 4 Ch. 100MHz Delay TB	£140
PM3335 Digital Storage Dual Trace 60MHz 20 MS/S	£125
PM3337 Rack Mount Digital Storage Dual Trace 60MHz 20 MS/S	£125
PM3365A Digital Storage Dual Trace 100MHz 100 MS/S	£150

### HITACHI

V222 Dual Trace 20MHz DC Offset, Alt. Mag	£50
V522 Dual Trace 50MHz DC Offset, Alt. Mag	£65
V665 Dual Trace 60MHz Delay Sweep, Cursors etc	£75
V1065 Dual Trace 100MHz Delay Sweep, Cursors etc	£85
V1065A Dual Trace 100MHz Delay Sweep, Cursors etc	£95
V1150 4 Ch. 150MHz Delay Sweep, Cursors, DVM etc	£125

### HAMAG

203.4 Dual Trace 20MHz Component Tester	£75
203.6 Dual Trace 20MHz Component Tester	£85
305 Dual Trace 03MHz Analogue/Digital 40 MS/S per Channel Component Tester	£140
604.2 Dual Trace 60MHz Component Tester	£125

**STEWART of READING**  
17A King Street, Mortimer,  
Near Reading RG7 3RS  
Telephone: (0118) 933 1111  
Fax: (0118) 933 2375  
[www.stewart-of-reading.co.uk](http://www.stewart-of-reading.co.uk)  
9am-5pm Monday to Friday

Check out our website,  
1,000s of items currently in stock

Used Equipment – GUARANTEED.  
Most Manuals supplied  
Please check availability before ordering  
or calling.  
Prices plus carriage and VAT

We can supply back issues of *EPE* by post, most issues from the past five years are available. An *EPE* index for the last five years is also available at [www.epemag.com](http://www.epemag.com). Where we are unable to provide a back issue a photocopy of any one article (or one part of a series) can be purchased for the same price. Issues from Jan. 99 are available on CD-ROM – see page 61 – and back issues from recent years are also available to download from [www.epemag.com](http://www.epemag.com).

Please make sure all components are still available before commencing any project from a back-dated issue.

## DID YOU MISS THESE?

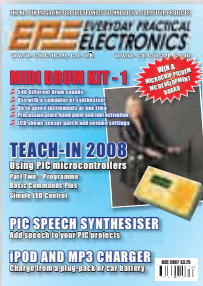

### DEC '07

**PROJECTS** • MIDI Drum Kit – 1 • PIC Speech Synthesiser • A Charger For Your iPod or MP3 Player • AVR ISP Socketboard  
**FEATURES** • Circuit Surgery • Techno Talk • Teach-In 2008 – Part 2 • PIC N' Mix • Interface • Protecting Your Designs and Copyright • Net Work – The Internet Page

### JAN '08

**PROJECTS** • MIDI Drum Kit – 2 • Phone/Fax Missed Call Alert • PIC Carillon • Serial I/O Controller and Analogue Sampler  
**FEATURES** • Circuit Surgery • Techno Talk • Teach-In 2008 – Part 3 • PIC N' Mix • Practically Speaking • Ingenuity Unlimited • Net Work

### FEB '08

**PROJECTS** • Electromog Sniffer • Low-Cost Intercooler Water Spray Controller • Studio Series – Stereo Preamplifier • Midi Drum Kit – 3  
**FEATURES** • Colossus and Pico • Interface • Teach-In 2008 – Part 4 • Circuit Surgery • Techno Talk • PIC N' Mix • Ingenuity Unlimited • Net Work – The Internet Page

### MAR '08

**PROJECTS** • Studio Series – Stereo Headphone Amplifier • Midi Drum Kit – 4 • Fluorescent Tube Driver • Multi Throttle Control For PC Flight Simulators  
**FEATURES** • Practically Speaking • Teach-In 2008 – Part 5 • Circuit Surgery • Techno Talk • PIC N' Mix • Net Work – The Internet Page

### APR '08

**PROJECTS** • PC-Controlled Burglar Alarm System – 1 • Studio Series – Remote Control Module • PIC In-Circuit Programming Add-on • Midi Activity Detector  
**FEATURES** • Circuit Surgery • Techno Talk • Teach-In 2008 – Part 6 • PIC N' Mix • Interface • Net Work – The Internet Page

### MAY '08

**PROJECTS** • Mini Theremin – 1 • Studio Series – Installing The Modules • Electric Mobility Buggy Monitor • PC-Controlled Burglar Alarm System – 2  
**FEATURES** • Circuit Surgery • Techno Talk • Teach-In 2008 – Part 7 • Practically Speaking • Net Work – The Internet Page

### JUN '08

**PROJECTS** • Universal High-Energy LED Lighting System – Part 1 • Starship Enterprise Door Sounder • Mini Theremin – Part 2 • Monopoly Money  
**FEATURES** • Circuit Surgery • Techno Talk • Teach-In 2008 – Part 8 • PIC N' Mix • Ingenuity Unlimited • Interface • Net Work – The Internet Page

### JUL '08

**PROJECTS** • PIC MIDI Wave Sound Generator • Universal High-Energy LED Lighting System – Part 2 • Coolmaster • Galactic Voice  
**FEATURES** • Teach-In 2008 – Part 9 • Circuit Surgery • Techno Talk • PIC N' Mix • Ingenuity Unlimited • Practically Speaking • Net Work – The Internet Page

### AUG '08 (PHOTOCOPIES ONLY)

**PROJECTS** • Four-Channel A/V Selector • Mains Monitor • DC Relay Switch • Temperature Switch  
**FEATURES** • Teach-In 2008 – Part 10 • Circuit Surgery • Interface • Ingenuity Unlimited • Techno Talk • PIC N' Mix • Net Work – The Internet Page

### SEPT '08

**PROJECTS** • Super Speedo Corrector • Ultrasonic Eavesdropper • S-Video To

Composite Video Converter • Magnetic Cartridge Preamplifier  
**FEATURES** • Techno Talk • Practically Speaking • Teach-In 2008 – Part 11 • PIC32 Starter Kit Review • Circuit Surgery • PIC N' Mix • Net Work

### OCT '08

**PROJECTS** • Cordless Power Tool Charger Controller • Intelligent Car Air-Conditioning Controller • 20W Class-A Amplifier Module • Breadboarding Projects – Circuit Tester, Rain Check • Ingenuity Unlimited  
**FEATURES** • Techno Talk • Recycle It • Interface • Circuit Surgery • PIC N' Mix • Net Work.

### NOV '08

**PROJECTS** • Low Cost 50MHz Frequency Meter – Mk2 • Using the Microchip PICkit2 Debug Express To Build A 'Theremin' • 20W Class-A Amplifier Module – Pt 2 • Simple Variable Boost Control • Fuel Cut Defeater • Breadboarding Projects – Dark Switch, Moisture Monitor Mk1 • IU  
**FEATURES** • Techno Talk • Recycle It • Practically Speaking • Circuit Surgery • PIC N' Mix • Net Work.

### DEC '08

**PROJECTS** • Radar Speed Gun – Part 1 • 20W Class-A Amplifier Module – Pt 3 • Programmable Christmas Star • Using the Microchip PICkit2 Debug Express To Build A 'Capacitive Switch' • Breadboarding Projects – Thermostat, Games Timer • Ingenuity Unlimited.  
**FEATURES** • Techno Talk • Recycle It • Interface • Circuit Surgery • PIC N' Mix • Net Work.

## BACK ISSUES ONLY

# £4.20

each inc. UK p&p.

Overseas prices £5.00 each surface mail, £6.00 each airmail.

We can also supply issues from earlier years: 2003 (except June), 2004 (except June, July, Oct. and Dec.), 2005 (except Feb., Nov., Dec.), 2006 (except Jan., Feb., Mar., Apr., May, and July), (2007 except June, July, Aug) Where we do not have an issue a photocopy of any **one article** or **one part** of a series can be provided at the same price.

## ORDER FORM – BACK ISSUES – PHOTOCOPIES – INDEXES

Send back issues dated.....

Send photocopies of (article title and issue date) .....

Name .....

Address.....

..... Tel: .....

I enclose cheque/P.O./bank draft to the value of £.....

Please charge my Visa/Mastercard/Maestro £.....

Card No..... Maestro Issue No.....

Valid From..... Card Expiry Date..... Card Security Code.....  
 (The last 3 digits on or just under the signature strip)

SEND TO: **Everyday Practical Electronics, Wimborne Publishing Ltd., Sequoia House, 398a Ringwood Road, Ferndown, Dorset BH22 9AU.**  
 Tel: 01202 873872. Fax: 01202 874562.  
**E-mail:** [orders@epemag.wimborne.co.uk](mailto:orders@epemag.wimborne.co.uk) **On-line Shop:** [www.epemag.com](http://www.epemag.com)  
 Payments must be in £ sterling – cheque or bank draft drawn on a UK bank. Normally supplied within seven days of receipt of order.  
 Send a copy of this form, or order by letter if you do not wish to cut your issue.



M01/09

# STORE YOUR BACK ISSUES ON CD-ROMS



- VOL 1: BACK ISSUES** – January 1999 to June 1999  
Plus some bonus material from Nov and Dec 1998
- VOL 2: BACK ISSUES** – July 1999 to December 1999
- VOL 3: BACK ISSUES** – January 2000 to June 2000
- VOL 4: BACK ISSUES** – July 2000 to December 2000
- VOL 5: BACK ISSUES** – January 2001 to June 2001
- VOL 6: BACK ISSUES** – July 2001 to December 2001
- VOL 7: BACK ISSUES** – January 2002 to June 2002
- VOL 8: BACK ISSUES** – July 2002 to December 2002
- VOL 9: BACK ISSUES** – January 2003 to June 2003
- VOL 10: BACK ISSUES** – July 2003 to December 2003
- VOL 11: BACK ISSUES** – January 2004 to June 2004
- VOL 12: BACK ISSUES** – July 2004 to December 2004
- VOL 13: BACK ISSUES** – January 2005 to June 2005
- VOL 14: BACK ISSUES** – July 2005 to December 2005
- VOL 15: BACK ISSUES** – January 2006 to June 2006
- VOL 16: BACK ISSUES** – July 2006 to December 2006
- VOL 17: BACK ISSUES** – January 2007 to June 2007
- VOL 18: BACK ISSUES** – July 2007 to December 2007
- VOL 19: BACK ISSUES** – January 2008 to June 2008

**NOTE:** These CD-ROMs are suitable for use on any PC with a CD-ROM drive. They require Adobe Acrobat Reader (available free from the Internet – [www.adobe.com/acrobat](http://www.adobe.com/acrobat))

## WHAT IS INCLUDED

All volumes include the *EPE Online* editorial content of every listed issue, plus links to all the available **PIC Project Codes** for the PIC projects published in those issues. **Please note that we are unable to answer technical queries or provide data on articles that are more than five years old. Please also ensure that all components are still available before commencing construction of a project from a back issue.**

**VOL 19  
NOW AVAILABLE**

**ONLY  
£16.45**  
each including VAT and p&p

A great way to buy EPE Back Issues – our CD-ROMs contain back issues from our *EPE Online* website plus bonus articles, all the relevant PIC software links and web links. **Note: no free gifts are included.**

**Order on-line from**  
[www.epemag.com](http://www.epemag.com)  
or by phone, fax, email or post

## BACK ISSUES CD-ROM ORDER FORM

Please send me the following Back Issue CD-ROMs.

Volume Numbers: .....

**Price £16.45 each** – includes postage to anywhere in the world.

Name .....

Address .....

Post Code .....

I enclose cheque/P.O./bank draft to the value of £ .....

please charge my Visa/Mastercard/Maestro £ .....

Card No. ....

Card Security Code ..... (The last 3 digits on or just under the signature strip)

Valid From ..... Expiry Date .....

Maestro Issue No. ....



**SEND TO: Everyday Practical Electronics,  
Wimborne Publishing Ltd., Sequoia House, 398a Ringwood  
Road, Ferndown, Dorset BH22 9AU.**

Tel: 01202 873872. Fax: 01202 874562.

E-mail: [orders@epemag.wimborne.co.uk](mailto:orders@epemag.wimborne.co.uk)

Payments must be by card or in £ Sterling – cheque or bank draft drawn on a UK bank.

Normally supplied within seven days of receipt of order.



## Slew rate limiting

**USER Terry** posted the following question on the *EPE Chatzone* forum (access via [www.epemag.com](http://www.epemag.com)):

*I want to add a low-pass filter to an accelerometer so that its output can be sampled by a PIC. The filter needs to be able to limit the voltage change to less than 0.1V per second and both the attack and decay need to be equal. Can anyone point me to any info that may help?*

Terry does not explain why he wants the rate of change limited, so we cannot give very specific advice. However, this question raises the issue of slew rate and how slew rate limiting is different from conventional low pass filtering. Therefore, this month we will take a general look at slew rate and its influence on signals. We will also look at how we might design a slew rate limiter and consider a published circuit design which might meet Terry's requirements.

The voltage (or current) at the output of any circuit can only change at a certain maximum rate. This is determined by factors such as the current available to drive internal capacitive nodes. The maximum rate of change of the output voltage,  $V_o$ , is the (voltage) called the slew rate,  $s$ . Mathematically we write:

$$s = \left. \frac{dV_o}{dt} \right|_{\max}$$

Where  $dy/dx$  is the notation used in calculus for the *differential*, or rate of change of a quantity  $y$  (voltage in this case) in response to a change in  $x$  (time in this case). If we are less mathematically inclined we can define slew rate as:

$$\text{slew rate} = \frac{\text{maximum output voltage change}}{\text{time taken to change}}$$

If the demand (ie input to the circuit) requires the output to change faster than the slew rate, then the circuit will fail to do so, that is, it will fail to 'keep up' with what the demand is requiring it to do. This may be beneficial or detrimental depending on the situation in which it occurs.

Slew rate is often looked at as a performance limiting factor; that is, the more slew rate you have the better, because the demand is faithfully responded too, implying an undistorted output. Unwanted slew rate limiting is probably best known

in the context of amplifiers, including operational amplifiers (op amps).

However, there are occasions when it is necessary to limit slew rate. Deliberate slew rate limiting is used (for example) to reduce electromagnetic interference (EMI) by reducing the high frequency energy in a signal, reducing voltage spikes induced by stray inductance, and keeping mechanical parts moving within safe acceleration limits when driven by electronic controllers.

### Op amp slew rate

We will now take a look at the slew rate limit of op amps to observe the effect it may have on circuit performance. We will see how this differs from effects due to output voltage range and low-pass filtering.

For amplifiers, including op amps, slew rate limits the maximum available output swing at high frequencies due to the distortion that occurs if the output cannot move fast enough to follow the required waveform. When an amplifier is slew rate limited it behaves in a non-linear manner. In extreme cases very high levels of distortion occur, for example, an input sinewave will result in an output triangular wave.

For an amplifier with a maximum output voltage,  $V_m$ , the frequency at which it can output an undistorted sinewave of magnitude  $V_m$  is called the full-power bandwidth (FPBW).

If you know calculus you will recall that the differential of a sine function is a cosine and we can use this to work out the relationship between required slew rate, amplitude and frequency. If you have not studied calculus don't worry about it, just skip the next paragraph to the full power bandwidth defining equation below.

For a sinewave output signal  $V_o$  with peak amplitude  $V_m$  and frequency  $\omega$ , we can write:

$V_o = V_m \sin \omega t$  so  $dV_o/dt = \omega V_m \cos \omega t$ . Thus a slew rate of

$$s = \left. \frac{dV_o}{dt} \right|_{\max} = \omega V_m$$

is required to 'keep pace' with the fastest part of the sinusoid and distortion will occur if  $\omega V_m > s$ .

This gives a full power bandwidth of

$$FPBW = \frac{s}{2\pi V_m}$$

Where  $s$  is the slew rate in volts per second and  $V_m$  is the peak signal amplitude in volts. Most op amps can produce output voltages close to the supply rail voltages, so  $V_m$  is typically equal to the supply voltage (for a split supply around ground).

### Output swing

At low frequencies, the maximum peak undistorted output swing of an amplifier is limited by the power supply voltage. At high frequencies it is limited by the slew rate. This is illustrated by Fig.1, which is a graph of the maximum amplitude undistorted sinewave against frequency that can be output by a 741 operational amplifier (operating on  $\pm 15V$ ).

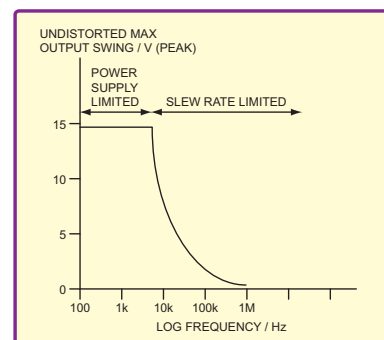

Fig.1. Approximate graph of maximum undistorted sinewave output amplitude for a 741 operational amplifier on using 15V supplies

The 741 is an old, low performance, but well known device. It has a slew rate of about  $0.5V/\mu s$ . We can also write this as  $50000V/s$ , but slew rates for op amps are typically quoted in volts per microsecond. On a  $\pm 15V$  supply it would take the 741  $15/500000 = 30\mu s$  to change its output voltage from  $0V$  to  $15V$  in response to a suitable step-change input.

The 741 has a poor slew rate, more modern devices with similar slew rates tend to be very high precision op amps with very low offsets, massively outperforming the 741 in these respects. Very much faster amplifiers are available of course. For example, the AD8009 from Analog Devices is an ultra high-speed current feedback amplifier with a slew rate of  $5500V/\mu s$  (5500 megavolts per second).

The formula for full power bandwidth gives us  $FPBW = 500000 / (2 \times \pi \times 15)$

= 5.3kHz for the 741 for a 15V peak sine-wave. Below this frequency, the op amp is supply limited and can output a sinewave with peak amplitude close to the supply voltage. Above the FPBW frequency the maximum output amplitude drops, as shown on Fig.1. To achieve a 100kHz undistorted sine output signal the amplitude must be less than 1V peak.

## Power bandwidth

Full power bandwidth limitations sometimes confound inexperienced circuit designers. The 741's datasheet states that the bandwidth is around 1MHz, so if one is unaware of slew rate limitations it is an easy mistake to assume that an amplifier built using the 741 can output a 15V sine-wave at hundreds of kilohertz. The FPBW of 5.3kHz in Fig.1 shows us that this is not the case.

Bandwidth, as opposed to FPBW, is defined for arbitrarily small signal amplitude. FPBW is not always quoted on op amp datasheets because it is dependent on the supply voltage used. However, using the formula given you can always work it out from the slew rate, which will be stated.

In Fig.2 is shown the effect of slew rate limiting on a sinewave. The required sinewave output changes faster than the amplifier can respond, so the amplifier output simply ramps up at the slew rate, trying to 'catch up' with the required output. Eventually, once the sinewave has started the downward part of its cycle, the output voltage equals the demanded value, but at this point the required output voltage is already decreasing at a rate faster than

the amplifier can keep up with. The result is an output waveform of approximately triangular shape.

Below the full power bandwidth (FPBW) the amplifier's peak output voltage is power supply, rather than slew rate, limited. This is illustrated in Fig.3. The result of power supply limiting is clipping. It is clear from Fig.2 and Fig.3 that both effects can severely distort the signal, but in different ways.

For a sinewave, a low-pass filter will output the same signal as the input (assuming a gain of one) until the cutoff frequency, after which the output amplitude will diminish as frequency increases. A low-pass filter will not change the shape of a sinewave. An amplifier will behave like a low-pass filter in that the amplitude of signals beyond its bandwidth will be diminished.

We could refer to this as bandwidth limiting, but in contrast with slew rate and power supply limiting a sinewave will not be distorted by bandwidth limiting. This is illustrated in Fig.4. Note that phase shift is not shown here as we are primarily concerned with the shape of the waveforms in this discussion.

The effect of power supply, slew rate, and bandwidth limitation is also different in each case for square wave signals. This is illustrated in Figs 5, 6 and 7. In particular, note that both slew rate and bandwidth limiting reduce the rise time of a square wave, but they differ in that slew rate limitation produces a linear ramping output voltage (Fig.5) whereas bandwidth limitations will give a response slowing on an exponential curve as it approaches the final amplitude (Fig.7).

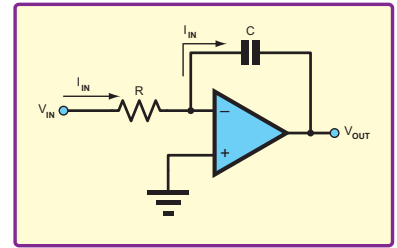

Fig.8. Operational amplifier integrator circuit

## Integration

The preceding discussion makes some simplifications. In many cases, both slew rate and bandwidth effects will be present together. In particular, the corners of the triangular waveforms and transitions from sloping to flat portions of waveforms will be rounded in real circuits.

We have seen that slew rate limiting is different from ordinary low-pass filtering, so Terry may need to use a more specific slew rate limiting circuit for his application. Readers familiar with basic op amp circuits may be thinking that an integrator circuit can produce a ramp output which certainly looks similar to the slew rate limited waveforms we have seen above.

An op amp integrator circuit is shown in Fig.8. As the gain of the op amp is very high, the voltage difference across the inputs will be very small. Since the non-inverting input is grounded, the inverting input will be very close to 0V and will behave as if it is grounded. This is known as a 'virtual earth'. If we assume that the inverting input behaves as if it is grounded

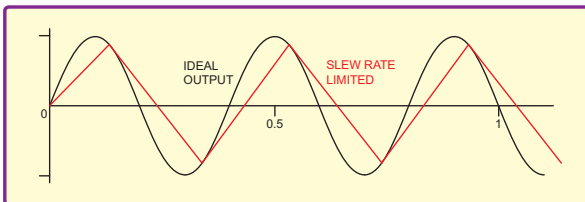

Fig.2. Effect of slew rate limiting on a sinewave. The output is severely distorted into a triangular shape

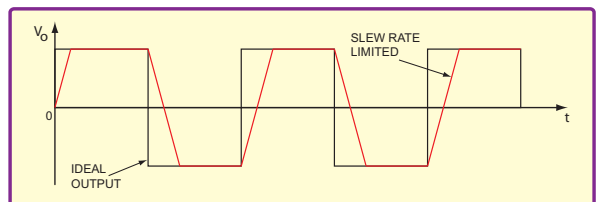

Fig.5. Effect of slew rate limiting on a square wave. The rise time is increased

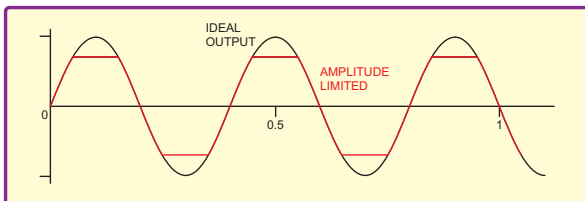

Fig.3. Effect of slew amplitude limiting on a sinewave. The output is clipped

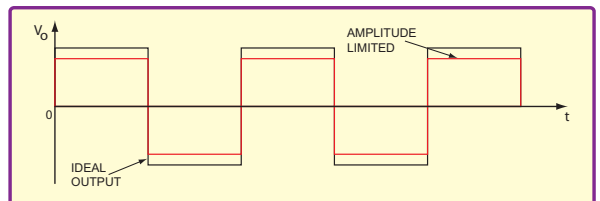

Fig.6. Effect of amplitude limiting on a square wave. The output is clipped

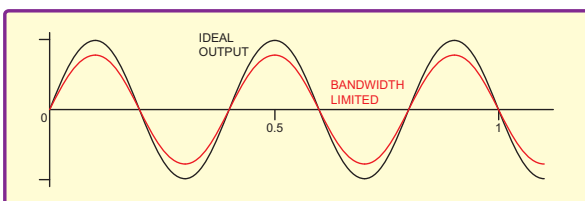

Fig.4. Effect of low-pass filtering a sinewave. There is no distortion, but the amplitude may be reduced. There may also be phase shift (not shown)

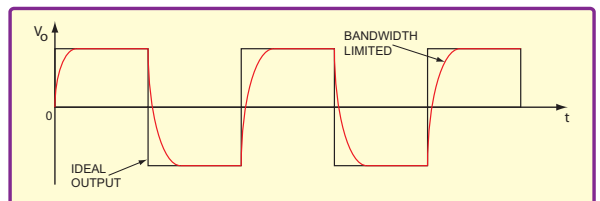

Fig.7. Effect of low-pass filtering a square wave. The waveform becomes more rounded as high frequency components of the signal are reduced

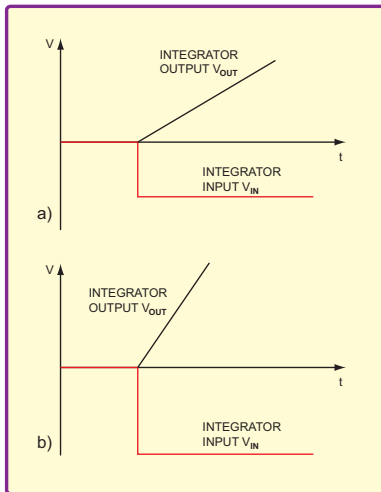

Fig.9. Output from integrator with step input. The output voltage ramps up linearly until the op amp saturates (not shown). The graphs (a) and (b) show that changing the input voltage changes the rate of change of the output

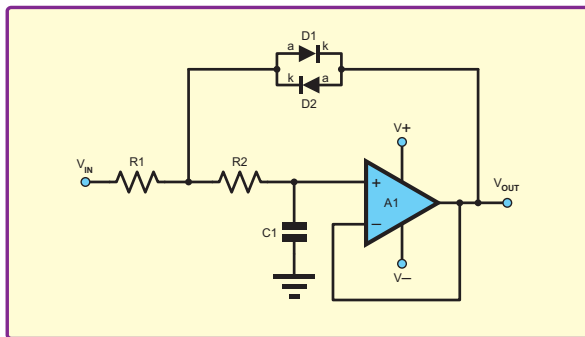

Fig.12. Andrew William's Slew Rate Limiter Circuit (see reference)

then applying an input voltage of  $V_{in}$  will result in a current  $I_{in}$  given by  $V_{in}/R$ .

If the op amp has very high input impedance then we can assume that all the input current flowing through R flows into the capacitor. If a constant current flows into a capacitor the voltage across it will rise as a linear ramp. So, if we start with 0V across the capacitor in the circuit in Fig.8 and then apply a fixed negative input voltage to get a constant current into the capacitor, then the output voltage will ramp up linearly until the op amp saturates. We need a negative input voltage for a positive output ramp because of the inverting nature of the circuit.

The graphs in Fig.9 illustrate the response of the integrator circuit to a step input. The graphs (a) and (b) show that changing the input voltage changes the rate of change of the output. This is because the ramping rate is proportional to the current flowing into the capacitor, which in turn is proportional to the input voltage. This is not what we want from a slew rate limiter, for which we would expect the rate of change of the output to be

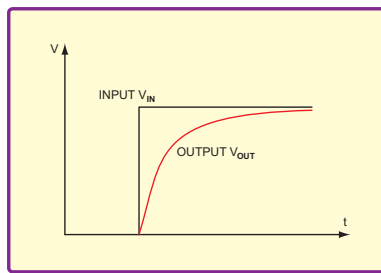

Fig.10. Output from RC low pass filter with step input. The output voltage rate of change changes continuously, slowing as the output voltage increases

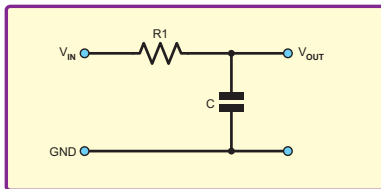

Fig.11. RC low-pass filter

independent of the input voltage.

For comparison, Fig.10 shows the response from an RC low-pass filter (Fig.11). It is likely to be less suitable as the basis of a slew rate limiter due to its variable rate of output change. The rate changes because as the output voltage increases the drop across the resistor decreases, causing the current flowing into the capacitor to decrease.

## Practicalities

The integrator gets us some way towards a slew rate limiter. What we need is a circuit which charges or discharges a capacitor using a fixed current if the input signal differs from the output, otherwise the current flowing into the capacitor is zero and it holds its charge. There are a

number of possible ways of doing this. For example, a transconductance op amp (eg LMI3700) could be used as the current source.

Another approach is shown in Fig.12. This circuit was published by Andrew Williams in *Electronic Design* in 1998. Again we use the fact that the voltage difference between the inputs of the op amp are very small, so the amplifier side of resistor R2 will be at about  $V_{out}$ . If the input voltage differs from this by a diode drop or more, then one of the diodes will turn on and clamp the junction of R1 and R2 at one diode drop away from  $V_{out}$ . Thus, the voltage across R2 will be more or less constant at one diode drop.

The constant voltage drop across R2 will produce a constant current which will flow into C1. As with the integrator, we assume that the op amp has very high input impedance, so all the current flows into C1. Also, like the integrator, this will cause the voltage across C1 to ramp up linearly or down. However, unlike the integrator, the current depends on the fixed diode drop, rather than the variable input voltage. Therefore the slew rate is constant while the input voltage differs from the output by a diode drop or more.

If the input voltage is equal to the output voltage, then the drop across R2 will be zero and no current will flow into or out of the capacitor. The output will therefore remain steady at this value until the input changes again. The slew rate is the same for falling and rising signals, so meets Terry's requirement in that respect.

The circuit will only work effectively if R1 is much smaller than R2 and the input signal is significantly larger than a diode voltage drop. For more details on the circuit operation, diode selection and typical waveforms please consult the reference.

## Reference

Andrew Williams, 'Special Low-Pass Filter Limits Slope', *Electronic Design*, 25 May 1998, p120, published by Penton Media/Planet EE ([www.penton.com](http://www.penton.com)), ISSN (printed) 0013-4872. Available online from <http://electronicdesign.com/>, enter ED Online ID #6294 in search box for the article.





save the installation program rather than delete it – you may want to reinstall the software at a later time, should you make a mistake during the configuration steps that follow later in this article. The author did, several times!

We will return to the installed software in a moment. First, let's take a look at this month's circuit diagram.

## Circuit details

In Fig.1 is shown the complete circuit diagram for the enhanced embedded webserver, including the Ethernet interface. The main changes are the addition of a 25LC1024 128KB EEPROM device and an LM317 voltage regulator. We are using a slightly different processor here, the PIC18LF2620, which can operate down to 3.3V. We have done this so that all the ICs can operate at the same voltage, removing the need for an additional 'interfacing' IC.

The processor crystal frequency has changed too – in this design we run the processor at 20MHz. Why the change? The reason, as some readers on the *Chat Zone* have discovered, is that the maximum speed a PIC processor can run reduces as the supply voltage drops below 5V. It's not immediately obvious that limitations exist when running at lower voltages – always read the datasheet!

Using a supply voltage of 3.3V has a number of advantages. Apart from the fact that the ENC28J60 only works at this voltage, many of the larger capacity serial memory ICs are only supplied as a low voltage type. While we use the relatively small memory 25LC1024, the Microchip stack software supports much larger serial flash devices such as the SST25VF016B, which provides a whopping 2MB storage. We have used the smaller 128KB EEPROM IC to show just how little memory you actually need.

Besides the SPI interface pins to the Ethernet and EEPROM chips, we also connect two LEDs on Ports RA0 and RA1 of the processor, a switch to RB5 and a relay to RA2. With the exception of the relay, these I/O pin allocations are chosen because they match very closely to one of the 'hardware profiles' used by the stack software, and so to minimise the amount of code we need to write we will stick as closely as possible to an existing profile. Adding the relay will enable us to produce a design that could find a practical use, such as turning equipment on and off remotely.

## Hardware profiles

The TCP/IP stack software supplied by Microchip does not just contain the low level protocol software – the designers have included some sample working applications that have been written to run on one of the development boards that Microchip produce. Five applications have been included, and we have based our project on the **TCPIP Demo App** application, simply because this seems to be the closest to what we want – a simple webserver.

Microchip have been kind enough to place all the hardware-specific software options within a single file, **hardwareprofile.h**, which resides in the TCPIP Demo App directory. This file, which is a C language header file, contains a series of '#define' statements that map circuit connections

(such as the switches, LEDs and memory ICs) to peripheral ports within the processor. These '#define' statements are then used by the TCPIP Demo App source code files.

When one examines the file, it becomes clear that there are a number of different development boards that are supported: PICDEMNET2, PICDEMZ, EXPLORER\_16 and others. Looking further in the file it becomes clear that the PICDEMZ hardware configuration is a good candidate for a simple circuit – it has two LEDs, a single button and an EEPROM IC. The circuit in Fig.1 has therefore been based on the PICDEMZ hardware definition. You could, of course, just go and buy a PICDEMZ development board, but where would the fun be in that?

Even though our circuit is based on the PICDEMZ board, it is not entirely similar – we have chosen to use a different processor which is smaller and cheaper. So we do have a few changes to make in this file.

Open the **hardwareprofile.h** file in a text editor or MPLAB. Search for the text '18F4620'. It appears in three places; change all of these references to 18F2620, being careful not to modify any of the surrounding text. At the last reference found, on the next two lines should appear a **#pragma config** statement. Change the setting of the parameter **OSC=HSPLL** to **OSC=HS**.

Now search the file for the text 'PICDEMZ'. When you find the line containing this text that is followed by a **#define GetSystemClock()** statement, change the value from 16000000ul to 20000000ul. This is a very important setting, since it is how we 'tell' our program at what frequency the main processor oscillator is running. All other timing dependant values are derived from this value. Having made the changes, save the file and close it.

We have now provided the stack software with the information about our circuit configuration. Now we need to configure the stack software itself and decide what features we want included in our application.

There are many optional and configurable features, so many in fact that Microchip have produced a utility program (a 'wizard', as Microsoft calls them) to help you select the features you require. All the changes you specify end up in a single header file called **TCPIPConfig.h** in the TCPIP Demo App directory. If you are brave enough, you could just edit the file yourself. We don't recommend you do, however!

## Setup wizard

To run the setup wizard, go to the Windows Start menu and select All Programs, then Microchip, TCPIP Stack v4.51, TCPIP Configuration Wizard. The program will prompt for the directory that contains the config header file you want to modify; make sure it points to **C:\Microchip Solutions\TCPIP Demo App**. Check that the 'Show Advanced Options' setting is ticked, and then click Next.

On the first configuration page you indicate the type of features you would like to enable. On this page, only Web Server should be ticked. Having made the changes, click Next. On the example modules page, untick all options and click Next. On the support modules page select ICMP Server and NetBIOS Name Service only. The ICMP Server module enables your webserver to

respond to 'Ping' requests, which is useful for checking that the device is working. The NetBIOS module enables your device to be given a simple text name, and be accessible under Microsoft Windows networking.

Click Next again, to the Network Configuration page. Here we must set the Ethernet and IP address settings, and this is where things get a little complicated. The MAC Address is a six-byte value that uniquely identifies your device on an Ethernet network. This address must be unique for any device connected on your network – but as you will typically be connecting the device either directly to your PC or into a router, you do not need to worry about selecting an address which is not globally unique – but if you place more than one device on your network, make sure each one has a unique address. For now, select a random number for the last three numbers in the MAC address, for example 27:FB:A5. Leave the first three numbers as 00:04:A3.

## Direct connection

For this month's article we will experiment with a direct connection between the device and a PC, and leave connecting the device onto the Internet for next month. So, for the IP address enter an address with is close to the IP address of your PC's Ethernet Interface. For example, 192.168.1.69 if your PC's IP address is 192.168.1.68. Set the Subnet Mask to 255.255.255.0, and the remaining three addresses to 0.0.0.0. Then click Next.

On the Web Server Configuration page select HTTP2. This option provides a more fully featured webserver, which allows for interesting and interactive webpages to be created. Click Next. On this page, we select some of the options for the Web Server itself. Change the Simultaneous Connections setting to 4, enable Authentication, POST support and File Upload, leaving Cookies and App Config disabled. Click Next. On the file system page check that MPFS2 is enabled. This feature enables the software that allows webpages to be stored and accessed in a simple way on the Web Server. Microchip provide a PC utility to convert your webpages into an MPFS2 file and download it to the webserver, making web page updates extremely simple. Microchip have put a lot of effort into the TCPIP stack software, and all for free!

Click Next again, and click on the External EEPROM radio button. Change the MPFS2 Options field to 9, and tick the 25LC1024 device box. This will enable the software that reads and writes to the EEPROM. Once again, no coding is required on our part to use this chip. Even the low level SPI interface routines are included.

Click Next again to get to the TCP Socket configuration page. Highlight each entry in the list on the left, and for each one set the Count field on the right to 0, with the exception of HTTP\_SERVER. Set that to a value of 4. Click Next again, set the Maximum UDP sockets to 1, and untick the Use TX Checksum field. Click Next, and then Finish.

That completes the configuration of the stack software; it's now ready to build. As you can see from the options presented, there is a wide range of features provided within the stack software, and if you look

through the code you will find examples of EEPROM access routines, LCD control and more. Once you have tested this webserver example program and become confident with configuring it, you may want to go back to the setup wizard and try enabling different features. As we haven't written any software yet, there is nothing to lose if you make a mistake – just run the wizard again, rebuild the software and re-flash the PIC.

## Building the code

Having closed the configuration wizard program it's now time to build the code. Run MPLAB, and open the project file **TCPIP Demo App-C18.mcw**. Click on the Configure menu option, followed by Select Device, and select PIC18F2620 from the device list. Now select Project and the Build All. After a short delay, the webserver program will be built. Program the resulting output file (TCPIP Demo App-C18.hex) into the processor in the normal way.

On powering up the device, both LEDs should illuminate, and one will start to flash slowly. Power down the device, then hold the button down and power the device back up again, keeping the button pressed. After a few seconds the LED should flash. This indicates that the PIC has initialised the EEPROM. You can now test the device by connecting it to your PC's Ethernet interface with a crossed-over CAT5 Ethernet cable. (If you only have a straight through Ethernet cable and do not mind

cutting it into two, you can create a crossed-over cable quite simply. Instructions can be found on the Internet, and a link is given at the end of this article.)

Once the cable is connected the LEDs on the Ethernet socket should illuminate, and one should start to flash. Once it has, open a command shell on your PC and type:

**ping 192.168.1.69** (or whatever your devices IP address is).

You should see a message indicating that the PC received a response. If not, the chances are that the IP address has not been set correctly.

Now, the device is working, but it has no web page data loaded in the EEPROM – we have only programmed the PIC, not the EEPROM IC. Web page files are loaded into the EEPROM through the Ethernet interface (of course!) using a Microchip utility program. From the PC's Start menu select All Programs, then Microchip, TCPIP Stack v4.51, and MPFS2. The dialog box that appears shows four options. For option 1, select the 'Webpage2 directory' button, and make sure the path is pointing to the Webpages2 directory. For option 2, select Bin Image. Leave options 3 and 4 as they are, and click on the 'Generate and Upload' button. This will translate the webpages from the Webpages2 directory into an MPFS2 format data file, and then upload them to the device. The process takes just a few seconds, which makes experimenting with new webpage content very easy.

Having uploaded the data, you can now open a web browser on your PC and enter the IP address of your device in the address field.

The example web pages supplied by Microchip give an introduction to the features of the stack code. The author's webserver at <http://mikehibbett.dyndns.org> has been changed slightly by modifying the html files in the webpages2 directory, and then uploading them to the device.

Next month, we will look at the software changes required to add the relay control, and explore the customisation of the web pages for our own needs. We will also explain how to hook-up your circuit to a broadband router so you can connect to the Internet.

All the components for the webserver circuit are readily available from hobbyist-friendly online suppliers such as Farnell, in both dual-in-line and surface mount formats. So there are no excuses for not getting the soldering iron out and building your own self-contained webserver!

## References

1. Microchip TCPIP Stack  
[www.microchip.com/stellent/idcplg?IdcService=SS\\_GET\\_PAGE&nodeId=2505&param=en535724](http://www.microchip.com/stellent/idcplg?IdcService=SS_GET_PAGE&nodeId=2505&param=en535724)
2. 25LC1024 EEPROM  
[www.microchip.com/wwwproducts/Devices.aspx?dDocName=en520389](http://www.microchip.com/wwwproducts/Devices.aspx?dDocName=en520389)
3. Cross over cable  
[www.digitgeek.com/how-to-make-a-crossover-ethernet-cable/](http://www.digitgeek.com/how-to-make-a-crossover-ethernet-cable/)

---

# Compact Control Design

Electronics and  
Software design

## Our capabilities

- PIC microcontroller applications
- Analogue and digital design
- Data acquisition
- Power supplies and power control
- Ultra low power applications
- GPRS/SMS communications
- USB, RS232/422/485, IrDA interfaces
- Schematic capture and PCB layout
- Firmware development in C and assembler
- Software development using C++ and visual studio

## Examples of completed projects

- Engine control unit, Diesel injector driver and USB-CANbus interface for a specialist automotive company.
- Modbus based 24 bit data acquisition system with direct connection to temperature and pressure sensors.
- Wave height and motion logging devices using GPRS and a PC based data analysis package.
- GPRS to ZigBee gateway for remote data acquisition.
- Data acquisition and analysis board for very high current sensing application.
- Controller system and PC interface software for paddles in a wave tank to simulate various wave profiles
- CCTV camera remote control for 4 monitors and up to 100 cameras.

Our regular customers include a world leading manufacturer of industrial analytical instruments and a leader in research and development of renewable energy systems.

Phone: 01260 281694.

Fax: 01260 501196.

[enquiries@compactcontrol.co.uk](mailto:enquiries@compactcontrol.co.uk)

77 Woolston Avenue,  
Congleton,  
Cheshire,  
CW12 3ED, UK  
Company number 5528711

EPE IS PLEASED TO BE ABLE TO OFFER YOU THESE

# ELECTRONICS CD-ROMS

## ELECTRONICS PROJECTS



Logic Probe testing

*Electronic Projects* is split into two main sections: **Building Electronic Projects** contains comprehensive information about the components, tools and techniques used in developing projects from initial concept through to final circuit board production. Extensive use is made of video presentations showing soldering and construction techniques. The second section contains a set of ten projects for students to build, ranging from simple sensor circuits through to power amplifiers. A shareware version of Matrix's CADPACK **schematic capture, circuit simulation and p.c.b. design** software is included.

The projects on the CD-ROM are: Logic Probe; Light, Heat and Moisture Sensor; NE555 Timer; Egg Timer; Dice Machine; Bike Alarm; Stereo Mixer; Power Amplifier; Sound Activated Switch; Reaction Tester. Full parts lists, schematics and p.c.b. layouts are included on the CD-ROM.

## ELECTRONIC CIRCUITS & COMPONENTS V2.0

Version 2

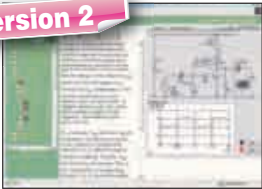

Circuit simulation screen

*Electronic Circuits & Components V2.0* provides an introduction to the principles and application of the most common types of electronic components and shows how they are used to form complete circuits. The virtual laboratories, worked examples and pre-designed circuits allow students to learn, experiment and check their understanding. Version 2 has been considerably expanded in almost every area following a review of major syllabuses (GCSE, GNVQ, A level and HNC). It also contains both European and American circuit symbols. Sections include: **Fundamentals:** units and multiples, electricity, electric circuits, alternating circuits. **Passive Components:** resistors, capacitors, inductors, transformers. **Semiconductors:** diodes, transistors, op amps, logic gates. **Passive Circuits. Active Circuits.** The **Parts Gallery** will help students to recognise common electronic components and their corresponding symbols in circuit diagrams.

Included in the Institutional Versions are multiple choice questions, exam style questions, fault finding virtual laboratories and investigations/worksheets.

## ANALOGUE ELECTRONICS

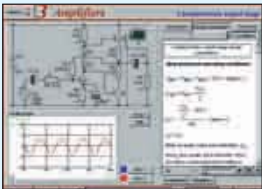

Complimentary output stage

*Analogue Electronics* is a complete learning resource for this most difficult branch of electronics. The CD-ROM includes a host of virtual laboratories, animations, diagrams, photographs and text as well as a SPICE electronic circuit simulator with over 50 pre-designed circuits.

Sections on the CD-ROM include: **Fundamentals** – Analogue Signals (5 sections), Transistors (4 sections), Waveshaping Circuits (6 sections), **Op Amps** – 17 sections covering everything from Symbols and Signal Connections to Differentiators. **Amplifiers** – Single Stage Amplifiers (8 sections), Multi-stage Amplifiers (3 sections). **Filters** – Passive Filters (10 sections), Phase Shifting Networks (4 sections), Active Filters (6 sections). **Oscillators** – 6 sections from Positive Feedback to Crystal Oscillators. **Systems** – 12 sections from Audio Pre-Amplifiers to 8-Bit ADC plus a gallery showing representative p.c.b. photos.

## DIGITAL ELECTRONICS V2.0

Version 2

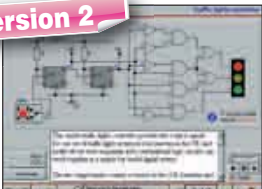

Virtual laboratory - Traffic Lights

*Digital Electronics* builds on the knowledge of logic gates covered in *Electronic Circuits & Components* (above), and takes users through the subject of digital electronics up to the operation and architecture of microprocessors. The virtual laboratories allow users to operate many circuits on screen.

Covers binary and hexadecimal numbering systems, ASCII, basic logic gates, monostable action and circuits, and bistables – including JK and D-type flip-flops. Multiple gate circuits, equivalent logic functions and specialised logic functions. Introduces sequential logic including clocks and clock circuitry, counters, binary coded decimal and shift registers. A/D and D/A converters, traffic light controllers, memories and microprocessors – architecture, bus systems and their arithmetic logic units. Sections on Boolean Logic and Venn diagrams, displays and chip types have been expanded in Version 2 and new sections include shift registers, digital fault finding, programmable logic controllers, and microcontrollers and microprocessors. The Institutional versions now also include several types of assessment for supervisors, including worksheets, multiple choice tests, fault finding exercises and examination questions.

## ANALOGUE FILTERS

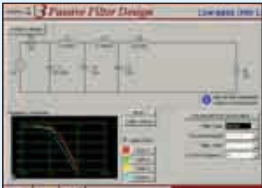

Filter synthesis

*Analogue Filters* is a complete course in designing active and passive filters that makes use of highly interactive virtual laboratories and simulations to explain how filters are designed. It is split into five chapters: **Revision** which provides underpinning knowledge required for those who need to design filters. **Filter Basics** which is a course in terminology and filter characterization, important classes of filter, filter order, filter impedance and impedance matching, and effects of different filter types. **Advanced Theory** which covers the use of filter tables, mathematics behind filter design, and an explanation of the design of active filters. **Passive Filter Design** which includes an expert system and filter synthesis tool for the design of low-pass, high-pass, band-pass, and band-stop Bessel, Butterworth and Chebyshev ladder filters. **Active Filter Design** which includes an expert system and filter synthesis tool for the design of low-pass, high-pass, high-pass, band-pass, and band-stop Bessel, Butterworth and Chebyshev op.amp filters.



## ROBOTICS & MECHATRONICS



Case study of the Milford Instruments Spider

*Robotics and Mechatronics* is designed to enable hobbyists/students with little previous experience of electronics to design and build electromechanical systems. The CD-ROM deals with all aspects of robotics from the control systems used, the transducers available, motors/actuators and the circuits to drive them. Case study material (including the NASA Mars Rover, the Milford Spider and the Furby) is used to show how practical robotic systems are designed. The result is a highly stimulating resource that will make learning, and building robotics and mechatronic systems easier. The Institutional versions have additional worksheets and multiple choice questions.

- Interactive Virtual Laboratories
- Little previous knowledge required
- Mathematics is kept to a minimum and all calculations are explained
- Clear circuit simulations

## PRICES

Prices for each of the CD-ROMs above are:  
(Order form on third page)

Hobbyist/Student .....	£44	inc VAT
Institutional (Schools/HE/FE/Industry) .....	£99	plus VAT
Institutional 10 user (Network Licence) .....	£249	plus VAT
Site licence .....	£499	plus VAT

(UK and EU customers add VAT at 15% to 'plus VAT' prices)

# PICmicro TUTORIALS AND PROGRAMMING

## HARDWARE

### VERSION 3 PICmicro MCU development board

*Suitable for use with the three software packages listed below.*

This flexible development board allows students to learn both how to program PICmicro microcontrollers as well as program a range of 8, 18, 28 and 40-pin devices from the 12, 16 and 18 series PICmicro ranges. For experienced programmers all programming software is included in the PPP utility that comes with the development board. For those who want to learn, choose one or all of the packages below to use with the Development Board.

- Makes it easier to develop PICmicro projects
- Supports low cost Flash-programmable PICmicro devices
- Fully featured integrated displays – 16 individual I.e.d.s, quad 7-segment display and alphanumeric I.c.d. display
- Supports PICmicro microcontrollers with A/D converters
- Fully protected expansion bus for project work
- USB programmable
- Can be powered by USB (no power supply required)

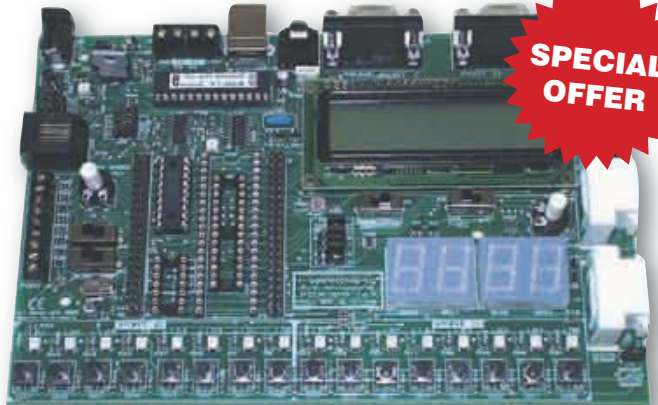

**SPECIAL OFFER**

**£155 including VAT and postage, supplied with USB cable and programming software**

**£40 OFF Buy the Development Board together with any Hobbyist/Student or Institutional versions of the software CD-ROMs listed below and take £40 off the total (including VAT) price.**

## SOFTWARE

### ASSEMBLY FOR PICmicro V3

**(Formerly PICtutor)**

Assembly for PICmicro microcontrollers V3.0 (previously known as PICtutor) by John Becker contains a complete course in programming the PIC16F84 PICmicro microcontroller from Arizona Microchip. It starts with fundamental concepts and extends up to complex programs including watchdog timers, interrupts and sleep modes.

The CD makes use of the latest simulation techniques which provide a superb tool for learning: the Virtual PICmicro micro-controller. This is a simulation tool that allows users to write and execute MPASM assembler code for the PIC16F84 microcontroller on-screen. Using this you can actually see what happens inside the PICmicro MCU as each instruction is executed which enhances understanding.

- Comprehensive instruction through 45 tutorial sections
- Includes Vlab, a Virtual PICmicro microcontroller: a fully functioning simulator
- Tests, exercises and projects covering a wide range of PICmicro MCU applications
- Includes MPLAB assembler
- Visual representation of a PICmicro showing architecture and functions
- Expert system for code entry helps first time users
- Shows data flow and fetch execute cycle and has challenges (washing machine, lift, crossroads etc.)
- Imports MPASM files.



### 'C' FOR 16 Series PICmicro Version 4

The C for PICmicro microcontrollers CD-ROM is designed for students and professionals who need to learn how to program embedded microcontrollers in C. The CD contains a course as well as all the software tools needed to create Hex code for a wide range of PICmicro devices – including a full C compiler for a wide range of PICmicro devices.

Although the course focuses on the use of the PICmicro microcontrollers, this CD-ROM will provide a good grounding in C programming for any microcontroller.

- Complete course in C as well as C programming for PICmicro microcontrollers
- Highly interactive course
- Virtual C PICmicro improves understanding
- Includes a C compiler for a wide range of PICmicro devices
- Includes full Integrated Development Environment
- Includes MPLAB software
- Compatible with most PICmicro programmers
- Includes a compiler for all the PICmicro devices.

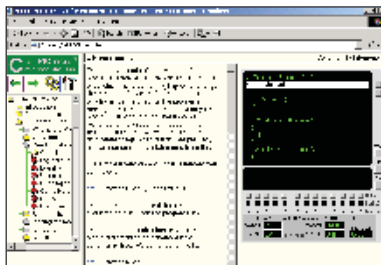

Minimum system requirements for these items: Pentium PC running Windows 98, NT, 2000, ME, XP; CD-ROM drive; 64MB RAM; 10MB hard disk space.

### FLOWCODE FOR PICmicro V3

Flowcode is a very high level language programming system for PICmicro microcontrollers based on flowcharts. Flowcode allows you to design and simulate complex systems in a matter of minutes. A Powerful language that uses macros to facilitate the control of devices like 7-segment displays, motor controllers and I.c.d.s. The use of macros allows you to control these devices without getting bogged down in understanding the programming.

Flowcode produces MPASM code which is compatible with virtually all PICmicro programmers. When used in conjunction with the Version 3 development board this provides a seamless solution that allows you to program chips in minutes.

- Requires no programming experience
- Allows complex PICmicro applications to be designed quickly
- Uses international standard flow chart symbols
- Full on-screen simulation allows debugging and speeds up the development process.

- Facilitates learning via a full suite of demonstration tutorials
- Produces ASM code for a range of 18, 28 and 40-pin devices
- New features in Version 3 include 16-bit arithmetic, strings and string manipulation, improved graphical user interface and printing, support for 18 series devices, pulse width modulation, I2C, new ADC component etc. The Hobbyist/Student version is limited to 4K of code (8K on 18F devices)

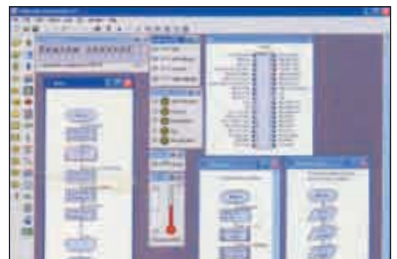

## PRICES

Prices for each of the CD-ROMs above are:  
(Order form on next page)

Hobbyist/Student .....	£44	inc VAT
Institutional (Schools/HE/FE/Industry) .....	£99	plus VAT
Institutional/Professional 10 user (Network Licence) .....	£300	plus VAT
Site licence .....	£599	plus VAT
Flowcode 10 user (Network Licence) .....	£350	plus VAT
Flowcode 50 user (Network Licence) .....	£699	plus VAT

(UK and EU customers add VAT at 15% to 'plus VAT' prices)



## SPECIAL PACKAGE OFFER

### TINA Pro V7 (Basic) + Flowcode V3 (Hobbyist/Student)

#### TINA Analogue, Digital, Symbolic, RF, MCU and Mixed-Mode Circuit Simulation, Testing and PCB Design

TINA Design Suite is a powerful yet affordable software package for analysing, designing and real time testing analogue, digital, MCU, and mixed electronic circuits and their PCB layouts. You can also analyse RF, communication, optoelectronic circuits, test and debug microcontroller applications.

Enter any circuit (up to 100 nodes) within minutes with TINA's easy-to-use schematic editor. Enhance your schematics by adding text and graphics. Choose components from the large library containing more than 10,000 manufacturer models. Analyse your circuit through more than 20 different analysis modes or with 10 high tech virtual instruments. Present your results in TINA's sophisticated diagram windows, on virtual instruments, or in the live interactive mode where you can even edit your circuit during operation.

Customise presentations using TINA's advanced drawing tools to control text, fonts, axes, line width, colour and layout. You can create, and print documents directly inside TINA or cut and paste your results into your favourite word-processing or DTP package.

TINA includes the following Virtual Instruments: Oscilloscope, Function Generator, Multimeter, Signal Analyser/Bode Plotter, Network Analyser, Spectrum Analyser, Logic Analyser, Digital Signal Generator, XY Recorder.

**Flowcode V3 (Hobbyist/Student)** – For details on Flowcode, see the previous page.

This offer gives you two separate CD-ROMs in DVD style cases – the software will need registering (FREE) with Designsoft (TINA) and Matrix Multimedia (Flowcode), details are given within the packages.

**Get TINA + Flowcode for a total of just £50, including VAT and postage.**

**£50.00  
inc. VAT  
and p&p**

### DIGITAL WORKS 3.0



#### Counter project

Digital Works Version 3.0 is a graphical design tool that enables you to construct digital logic circuits and analyze their behaviour. It is so simple to use that it will take you less than 10 minutes to make your first digital design. It is so powerful that you will never outgrow its capability • Software for simulating digital logic circuits • Create your own macros – highly scalable • Create your own circuits, components, and i.c.s • Easy-to-use digital interface • Animation brings circuits to life • Vast library of logic macros and 74 series i.c.s with data sheets • Powerful tool for designing and learning.

**Hobbyist/Student £44 inc. VAT.  
Institutional £99 plus VAT.  
Institutional 10 user £249 plus VAT.  
Site Licence £599 plus VAT.**

### ELECTRONIC COMPONENTS PHOTOS

A high quality selection of over 200 jpg images of electronic components. This selection of high resolution photos can be used to enhance projects and presentations or to help with training and educational material. They are royalty free for use in commercial or personal printed projects, and can also be used royalty free in books, catalogues, magazine articles as well as worldwide web pages (subject to restrictions – see licence for full details).

Now contains Irfan View image software for Windows, with quick-start notes included.

Price **£19.95** inc. VAT



## PROJECT DESIGN WITH CROCODILE TECHNOLOGY

### An Interactive Guide to Circuit Design

An interactive CD-ROM to guide you through the process of circuit design. Choose from an extensive range of input, process and output modules, including CMOS Logic, Op-Amps, PIC/PICAXE, Remote Control Modules (IR and Radio), Transistors, Thyristors, Relays and much more.

Click Data for a complete guide to the pin layouts of i.c.s, transistors etc. Click More Information for detailed background information with many animated diagrams.

Nearly all the circuits can be instantly simulated in Crocodile Technology\* (not included on the CD-ROM) and you can customise the designs as required.

#### WHAT'S INCLUDED

Light Modules, Temperature Modules, Sound Modules, Moisture Modules, Switch Modules, Astables including 555, Remote Control (IR & Radio), Transistor Amplifiers, Thyristor, Relay, Op-Amp Modules, Logic Modules, 555 Timer, PIC/PICAXE, Output Devices, Transistor Drivers, Relay Motor Direction & Speed Control, 7 Segment Displays. Data sections with pinouts etc., Example Projects, Full Search Facility, Further Background Information and Animated Diagrams.

#### Runs in Microsoft Internet Explorer

\*All circuits can be viewed, but can only be simulated if your computer has Crocodile Technology version 4.10 or later. A free trial version of Crocodile Technology can be downloaded from: [www.crocodile-clips.com](http://www.crocodile-clips.com). Animated diagrams run without Crocodile Technology.

**Over 150 pages  
Over 600 images**



**Single User £39.00 inc. VAT.**

**Multiple Educational Users (under 500 students) £59.00 plus VAT. Over 500 students £79.00 plus VAT.**

(UK and EU customers add VAT at 15% to "plus VAT" prices)

Minimum system requirements for these CD-ROMs: Pentium PC, CD-ROM drive, 32MB RAM, 10MB hard disk space. Windows 95/98/NT/2000/ME/XP, mouse, sound card, web browser.

### Please send me: **CD-ROM ORDER FORM**



- Electronic Projects
- Electronic Circuits & Components V2.0
- Analogue Electronics
- Digital Electronics V2.0
- Analogue Filters
- Electronics CAD Pack
- Robotics & Mechatronics
- Assembly for PICmicro V3
- 'C' for 16 Series PICmicro V4
- Flowcode V3 for PICmicro
- Digital Works 3.0

#### Version required:

- Hobbyist/Student
- Institutional
- Institutional/Professional 10 user
- Site licence

PICmicro Development Board V3 (hardware)

- TINA Pro V7 Basic + Flowcode V3 Hobbyist/Student
- Electronic Components Photos; Version 1.1
- Project Design – Single User
- Project Design – Multiple User (under 500 students)
- Project Design – Multiple User (over 500 students)

Note: The software on each version is the same, only the licence for use varies.

Full name: .....

Address: .....

Post code: ..... Tel. No: .....

Signature: .....

I enclose cheque/PO in £ sterling payable to WIMBORNE PUBLISHING LTD for £ .....

Please charge my Visa/Mastercard/Maestro: £ .....

Valid From: ..... Card expiry date: .....

Card No: ..... Maestro Issue No. ....

Card Security Code ..... (The last 3 digits on or just under the signature strip)

## ORDERING ALL PRICES INCLUDE UK POSTAGE

Student/Single User/Standard Version price includes postage to most countries in the world  
EU residents outside the UK add £5 for airmail postage per order

**Institutional, Multiple User and Deluxe Versions** – overseas readers add £5 to the basic price of each order for airmail postage (do not add VAT unless you live in an EU (European Union) country, then add 15% VAT or provide your official VAT registration number).

**Send your order to:  
Direct Book Service  
Wimborne Publishing Ltd  
Sequoia House, 398a Ringwood Road  
Ferndown, Dorset BH22 9AU**

To order by phone ring  
**01202 873872. Fax: 01202 874562**

Goods are normally sent within seven days

**E-mail: [orders@wimborne.co.uk](mailto:orders@wimborne.co.uk)**

Online shop:  
[www.epemag.com](http://www.epemag.com)

## UK readers you can SAVE 79p on every issue of EPE

How would you like to pay £3.16 instead of £3.95 for your copy of EPE?



Well you can – just take out a one year subscription and save 79p an issue, or £9.50 over the year. You can even save over £1 an issue if you subscribe for two years – a total saving of £24.30.

Overseas rates also represent exceptional value.

You also:

- Avoid any cover price increase for the duration of your subscription
- Get your magazine delivered to your door each month
- Ensure your copy, even if the newsagents sell out

Order by phone or fax with a credit card or by post with a cheque or postal order, or buy on-line from [www.epemag.com](http://www.epemag.com)

## EPE EVERYDAY PRACTICAL ELECTRONICS

### SUBSCRIPTION PRICES

Subscriptions for delivery direct to any address in the UK: 6 months £19.95, 12 months £37.90, two years £70.50; Overseas: 6 months £23.00 standard air service or £32.00 express airmail, 12 months £44.00 standard air service or £62.00 express airmail, 24 months £83.00 standard air service or £119.00 express airmail.

Cheques or bank drafts (in £ sterling only) payable to *Everyday Practical Electronics* and sent to EPE Subs. Dept., Wimborne Publishing Ltd., Sequoia House, 398a Ringwood Road, Ferndown, Dorset BH22 9AU, tel: 01202 873872. Fax: 01202 874562. Email: [subs@epemag.wimborne.co.uk](mailto:subs@epemag.wimborne.co.uk). Also via the Web at <http://www.epemag.com>.

Subscriptions start with the next available issue. We accept MasterCard, Maestro or Visa. (For past issues see the Back Issues page.)

### ONLINE SUBSCRIPTIONS

Online subscriptions, for downloading the magazine via the Internet, \$18.99US (approx. £10.00) for one year available from [www.epemag.com](http://www.epemag.com).

### SUBSCRIPTION ORDER FORM

- 6 Months: UK £19.95, Overseas £23.00 (standard air service), £32.00 (express airmail)  
 1 Year: UK £37.90, Overseas £44.00 (standard air service) £62.00 (express airmail)  
 2 Years: UK £70.50, Overseas £83.00 (standard air service) £119.00 (express airmail)

To: *Everyday Practical Electronics*,  
 Wimborne Publishing Ltd., Sequoia House,  
 398a Ringwood Road, Ferndown, Dorset BH22 9AU  
 Tel: 01202 873872 Fax: 01202 874562  
 E-mail: [subs@epemag.wimborne.co.uk](mailto:subs@epemag.wimborne.co.uk)

I enclose payment of £ ..... (cheque/PO in £ sterling only), payable to *Everyday Practical Electronics*

Please charge my Visa/Mastercard/Maestro

My card number is: .....  
 Please print clearly, and check that you have the number correct

Signature .....

Card Security Code ..... Valid From Date.....  
 (The last 3 digits on or just under the signature strip)

Card Ex. Date .....Maestro Issue No. ....

Name .....

Address .....

Post code ..... Tel. ....

Subscriptions can only start with the next available issue.





# READOUT

Email: [editorial@wimborne.co.uk](mailto:editorial@wimborne.co.uk)  
Matt Pulzer addresses some of the general points readers have raised. Have you anything interesting to say? Drop us a line!

All letters quoted here have previously been replied to directly



**WIN AN ATLAS LCR ANALYSER WORTH £79**  
An Atlas LCR Passive Component Analyser, kindly donated by Peak Electronic Design Ltd, will be awarded to the author of the Letter Of The Month. The Atlas LCR automatically measures inductance from 1mH to 10H, capacitance from 1pF to 10,000µF and resistance from 1Ω to 2MΩ with a basic accuracy of 1%. [www.peakelec.co.uk](http://www.peakelec.co.uk)

## ★ LETTER OF THE MONTH ★

### Obtaining the unobtainable

Dear EPE

Recently, I have come across several circuit diagrams and constructional details for transistorised transceivers of varying power, with ranges from 5km to 60km. These operate on the 27MHz waveband. I am not sure how old these circuit diagrams are, but I expect that they date back to the 1970s.

With the advent of the Internet, I have never experienced a problem with sourcing components. Not even for circuits that are many years old.

At the moment I do not have Internet facilities. So, I wrote out a list of transistor details compiled from these circuits and posted this to Cricklewood Electronics, together with a covering letter asking if they can supply any of the transistors on the list, and if not, could they supply any equivalents.

Within a few days I received a letter from them enclosing a list with prices of many of the transistors on the list and others where they had taken their time in researching for equivalent types. In fact, this week I have received four letters from electronic component suppliers. Three from UK companies and one from a company based in Barcelona, Spain. All have 'bent over

backwards' in their efforts to help.

I wouldn't say that the UK electronics industry is on its knees. It is a competitive market and with respect to electronics components, one in which it is more cost effective to sell via a website rather than a shop.

Turning to suppliers' 'postal charges', these are based on registered/certified postal costs. Due to the very nature of the products ordered it is necessary for the suppliers to insure against non-delivery, damage in transit – and thus, higher postal charges come into effect as a consequence.

Sourcing components can be fun. At times, one has to look further afield than the UK. It's not just the Internet that one can use. For example, a few years ago I identified a market in Spain on the Costa Blanca for installing antenna systems (TV) that incorporated a microwave down converter as its primary circuit. I knew the frequency range of the type I needed, but where to find a supplier who could provide these in wholesale amounts and prices? I did not know!

So a fax to the American Embassy – in Spain – asking them if they could provide details of any suppliers or manufacturers in the US for this item, resulted in a fax back – within 24 hours – with full details of four or five companies in the US who

supplied or manufactured 'microwave down converters'. Company details and contact names with telephone numbers. One month later – business!

A subsequent fax to the Taiwanese Embassy – in London – returned similar results.

So, perhaps no component is unobtainable.

Incidentally, these companies would have happily supplied me with just one down-converter. As to Maplin, I have never ordered from them, so I am unable to comment. With all due respect to Maplin I can't see a large company's staff 'bending over backwards' to research a client's list of transistor queries.

I prefer to pay a small company a few extra pounds and in return receive personal service. Could there be a business in 'sourcing unobtainable electronic components'?

**Steve Else, via email**

*And I thought I was good at tracking down the unobtainable. Pulling in diplomats to do the hard work is a stroke of genius! Many congratulations on your ingenuity. I certainly agree with your attitude to paying a little more for proper service – in the long run it is always money well spent.*

### Tracking down the LM1881

Dear EPE,

Would it help to know of further sources for LM1881? This is requested by Brian Williams in his letter 'Unobtainable Components'. Try the following:

CPC: SCLM1881N

Farnell: 948-8413 (surface-mount alternative also available)

Rapid: 82-5008

I've quoted the DIL package variant LM1881N, expect to pay just under £3 inc VAT for single examples or small quantities. Neither CPC nor Rapid have minimum order quantities, but small orders attract carriage charges. Both have wide ranges of general components as well, plus you'd be surprised at the breadth covered by CPC!

**Godfrey Manning, G4GLM, by email**

*Many thanks Godfrey, it's always handy to have multiple sources for components.*

### EPE downloading

Dear EPE,

I need some advice with EPE online downloads. I have never had any trouble in the past, and nothing has changed with my equipment/software. However, when trying to download the Dec 2008 issue (and now with any other issue) I always get an error in the last few seconds of download.

An email to Alvin suggested that 5000 other downloads have worked fine. I have had no problem with other downloads from a number of web pages.

I also tried IDM at Alvin's suggestion – same error, gives up seconds before completion when attempting opening and saving functions.

Can you help? Is there a server administrator to contact?

**Neil Evans, via email**

Alan Winstanley replied to Neil:

*I notice you are using Netscape, according to a Netscape/Mozilla forum here <http://home.att.net/~cherokee67/dlsourcfile.html>, this problem is due to a corrupted data file which should be deleted. It doesn't seem to be the downloading from us that's the problem, but rather the PC trying to decompress and launch the file, is where the problem seems to lie. The Mozilla forums are based on the same browser engines (more or less) as Netscape, and I soon turned up something similar in Mozillazine – [http://kb.mozillazine.org/Source\\_file\\_could\\_not\\_be\\_read](http://kb.mozillazine.org/Source_file_could_not_be_read)*

*I do think it is a browser-related, or software-related, error (eg, anti-spyware trying to cache and read the file before allowing you to run it). I have only had two or three other download problems reported – literally – and when I tried to reproduce the error here by using their logins, I just couldn't do it.*

As Alvin states on the home page, the site is optimised for IE7 or (better still) Firefox. I know all these things should work independently of whatever browser is used, but the reality is never quite ideal and there are other products that can interfere with the download process. Other software updates, including Windows XP updates, can interfere by overriding earlier settings.

My advice would be to try from an alternative machine, if only to compare results as a one-off exercise. Myself, I would also try running Firefox, which should hopefully run alongside Netscape, but I'm not entirely certain. Consider any scanning or spyware software that may be running, and disable it as a one-off exercise. And if you do still have IE available, you might want to hold your nose in the process and try that as well. Also, asking around in the Netscape user community might offer some pointers.

I hope that helps anyway, please keep me posted.

**Alan Winstanley,**  
On-line Editor

## Writing on PCBs

Dear EPE,

A couple of queries: first, do any readers know of a good way of clearly and finely writing on PCBs? For example, expected voltage levels. I use liquid paper and a technical drawing pen. Unfortunately, the liquid paper is a little too soft for such pens.

Second, I want a really good mail order hand tool supplier for the electronics industry. Tool Range of Upton-upon-

Severn were the leaders, but have gone out of business – who were their successors?

**James Garner**  
Ballymena, Co. Antrim

Can any reader suggest a good marking technique? Perhaps a fine-tipped indelible ink marker pen would work? I never used Tool Range, so I cannot comment on a replacement, but Farnell have an extensive range of tools, including some of the more 'esoteric' ones. Squires ([www.squirestools.com](http://www.squirestools.com)), who used to advertise with us, also carry a wide range of tools. There must be some readers' favorites – all comments welcome.

## Calibrating quartz watches

Dear EPE

I am writing on the off chance that you might have some inspiration about the following. I am retired and have started collecting some of the cheaper watches that one finds. I used to be a mechanical engineer and I like to see other people's solutions to age-old problems.

Some of the older quartz watches that I have come across have a tuning capacitor, but waiting and checking for errors is tedious and takes a long time. I have seen a Seiko apparatus that has a simple search coil and black box that does this directly. I have a multimeter that reads frequency and used it with a multiturn coil, but obviously the signal level is small and my set up didn't work. (Some clocks run at 4.19MHz and watches at about 32kHz.)

I don't want a very precise reading – I am more interested in getting a meaningful

trend without a complex circuit. I wonder if there is anything that I might use for the purpose. Perhaps one of your ingenious readers has already come up with a solution. I am happy with a soldering iron!

As a final question, a friend is interested in replacing the sub-miniature trimmers used in watches – any suggestions about sourcing these?

**Adam Cromarty**  
East Grinstead, West Sussex

Unfortunately, we have not published anything suitable, nor do we know of a suitable supplier of subminiature trimmers. You might be better off trying horology suppliers as opposed to electronic component retailers. A quick 'Google' brought up [www.watchparts.co.uk](http://www.watchparts.co.uk) (0844 800 7253) who may be able help or point you in the right direction.

## 50MHz Frequency Meter Mk.2

Dear EPE,

Thank you for my magazine, which I receive on-line.

While I welcome the Mk.2 version of the 50MHz Frequency Meter (EPE Nov '08), may I suggest that an easier way for the external DC supply to be managed is by simply disconnecting the negative side of the battery using the 'break' contact of the jack. With this rearrangement the battery gets disconnected, once the external power is plugged in.

**MVS Sarma, India, via email**

Many thanks Mr Sama, improvements to projects are always welcome from our inventive readers.

# Christmas Special Offers!



<h2 style="text-align: center;">Atlas Star Pack</h2> <p style="text-align: center;">Atlas DCA and Atlas LCR in Premium Carry Case</p> <div style="border: 1px solid black; padding: 5px; margin-bottom: 5px;"> <p style="text-align: center;"><b>Atlas DCA - Model DCA55</b></p> <p style="text-align: center;">Semiconductor Analyser</p> <p style="text-align: center;">Identifies type and pinout! Connect any way round. Measures gain, junction characteristics and more. Now with premium strong probes!!</p> </div> <div style="border: 1px solid black; padding: 5px;"> <p style="text-align: center;"><b>Atlas LCR - Model LCR40</b></p> <p style="text-align: center;">Passive Component Analyser</p> <p style="text-align: center;">Automatic component identification (inductor, capacitor or resistor). Auto frequency selection. Measures main component value and other parameters too such as the DC resistance of inductors automatically.</p> </div>  <p style="text-align: right; color: red; font-weight: bold; font-size: 1.2em;">only £129! you save £20!</p>	<div style="border: 1px solid black; padding: 5px; margin-bottom: 5px;"> <p style="text-align: center;"><b>Atlas ESR - Model ESR60</b></p> <p style="text-align: center;">Measure capacitance and ESR! Capacitance from 1uF to 22,000uF ESR from 0.01 ohms to 20 ohms Battery included + Gold plated croc clips</p> <p style="text-align: center;"><i>Features our unique automatic discharge function</i></p>  <p style="text-align: right; color: red; font-weight: bold; font-size: 1.2em;">only £79! normally £85!</p> </div> <div style="border: 1px solid black; padding: 5px; margin-bottom: 5px;"> <p style="text-align: center;"><b>LED Torch - Great Gift!</b></p> <p style="text-align: center;">Uniross Aluminium 6 LED Torch 150mm long 2 AA Batteries (included) Fabric Wrist Strap Sealed retail pack</p>  <p style="text-align: right; color: red; font-weight: bold; font-size: 1.2em;">only £3.95! normally £6.00!</p> </div>
<div style="border: 1px solid black; padding: 5px; margin-bottom: 5px;"> <p style="text-align: center;"><b>Atlas LCR</b></p> <p style="text-align: center;">see description in main offer</p>  <p style="text-align: right; color: red; font-weight: bold; font-size: 1.2em;">only £79</p> </div>	<div style="border: 1px solid black; padding: 5px;"> <p style="text-align: center;"><b>Atlas DCA</b></p> <p style="text-align: center;">see description in main offer</p>  <p style="text-align: right; color: red; font-weight: bold; font-size: 1.2em;">only £55 new probes!</p> </div>

Peak Electronic Design Ltd, West Road House, West Road, Buxton, Derbyshire, SK17 6HF.  
tel. 01298 70012 [www.peakelec.co.uk](http://www.peakelec.co.uk) [sales@peakelec.co.uk](mailto:sales@peakelec.co.uk)

Please add £2.00 p&p per order. Prices include UK VAT. See website for overseas prices. Special Offer prices for limited period or until stocks last.

# Net Work

Alan Winstanley



## Tree surgery

This column is specially written to support our Internet-enabled readership: many regular *EPE* readers will have noticed the recent upgrade to our online services with the merger of our UK website into *EPE* Online at [www.epemag.com](http://www.epemag.com).

The new site includes more news and timely content, not least of which is a *Net Work* column to support this printed column with more background and more links, generally making *Net Work* more interactive, and a blog is promised for the future. It's an exciting time to be involved with the expansion of our online presence.

At this stage, we would reassure readers of our commitment to publishing the printed version for the foreseeable future. As explained in the Oct '08 *Editorial*, regrettably some UK-based news vendors seem not to display the same commitment to distribute the quality printed word to a specialist and discerning audience such as the *EPE* readership: instead they strive to leverage punitive fees from small independent publishers for the privilege of seeing their titles on the shelves.

The *EPE* Online website upgrade also enables us to improve our online services, starting with the *Downloads* section, now to be found under the menu heading *Library*. (See the red outlined area on the accompanying screenshot.) Our project source code files have built up for well over a decade – indeed I recall the reader debate on Usenet in the mid-nineties about the distribution of our PIC project source codes, when *EPE* was the first magazine to decide to circulate these, where available, for free.

Readers will hopefully welcome the development that from this month, PIC files are available from the *Library* sorted (at last!) by month/year of issue. This supersedes the previous *Download* 'tree' of projects with arcane labels that had grown out of control and were in desperate need of pruning!

For the time being, and to enable our online files to be retrospectively compatible with material published in older back issues, PIC source codes up to the November 2008 issue will remain available on our legacy FTP site (<ftp://ftp.epemag.wimborne.co.uk/pub/PICS>). These can be accessed via a web browser such as Firefox with the FireFTP plug-in, or alternatively, I advocate WS-FTP Pro or Filezilla. We would also like to thank once again the sterling work of PIC enthusiast Thomas Stratford, who has maintained a mirror version of our PIC source codes for the benefit of readers over many years.

## Just the Library ticket

Also included in the new 'Library' section of *EPE* Online are printed circuit board/printed wiring board designs, again sorted by month

and year, starting with the March 2006 issue. These are delivered as PDFs, from which experimenters can print them onto their choice of PCB transfer products for direct etching onto glass-fibre boards. Both our source codes and PCB foils are grouped into .zip format files, enabling readers to download them more conveniently.

At this time free registration is necessary in order to access some of the extended content of *EPE* Online. Remember too that the downloadable version of *EPE* Magazine is available from [www.epemag.com](http://www.epemag.com) at a highly competitive price. It is usually available a few days earlier than the printed version arrives on the newsstands, and in

today's Internet-enabled world it is part of the general trend to move more services online at a competitive price and generally make them more accessible. Subscription deals are offered that makes *EPE* Online an irresistible bargain.

*EPE* Online is delivered as a PDF file (say 10 to 20MB or so) and the vast majority of readers are able to download the magazine with no problems whatsoever. Our homepage offers clear practical advice regarding the most reliable way of downloading our magazine. It is extremely wise to ensure that a current version of a web browser is used: in particular Internet Explorer 6 or earlier should be considered totally obsolete and should be upgraded immediately – or why not try the excellent free Firefox 3 browser from [www.firefox.com](http://www.firefox.com)? Popup blockers should not be enabled and automatic cookie override should be used.

For those wishing to purchase our range of books, CDROMs and back issues, we can now offer two choices: our USA-based store is priced in dollars and our UK store continues unchanged as before, delivering worldwide with no minimum order charge. The choice is entirely yours: either store is available via the link in the main menu at *EPE* Online. Readers of our sister magazine *Radio Bygones* are also supported at *EPE* Online.

*EPE* is working hard to evolve our online presence and we hope *EPE* readers will enjoy the extra benefits that they will start to see in coming months.

I would like to round off the final *Net Work* to appear in 2008 by thanking readers for their continued interest and feedback. Some readers open *EPE* and turn to *Net Work* first – and although I can't always promise to respond individually I do enjoy reading your emails. I offer all our readers season's greetings and here's hoping for a more prosperous, rewarding and constructive New Year!

You can email Alan at [alan@epemag.demon.co.uk](mailto:alan@epemag.demon.co.uk) and do remember to check *Net Work EPE* Online as well.



Our upgraded Internet presence has launched at [www.epemag.com](http://www.epemag.com) where you can access Downloads via the Library or buy online from our UK and USA stores. The red outline area shows the main menu, your key to navigating around the entire site.

## Electronics Teach-In + FREE CD-ROM

### Mike Tooley

A broad-based introduction to electronics – find out how circuits work and what goes on inside them. Plus 15 easy-to-build projects. The 152 page A4 book comes with a free CD-ROM containing the whole *Teach-In 2008* series (originally published in *EPE*) in PDF form, interactive quizzes to test your knowledge, TINA circuit simulation software (a limited version – plus a specially written TINA Tutorial), together with simulations of the circuits in the Teach-In series, plus Flowcode (a limited version) a high level programming system for PIC microcontrollers based on flowcharts.

The Teach-In series covers everything from Electric Current through to Microprocessors and Microcontrollers and each part includes demonstration circuits to build on breadboards or to simulate on your PC.

In addition to the Teach-In series, the book includes 15 CMOS-based simple projects from the *Back-To-Basics* series by Bart Trepak, these are: Fridge/Freezer Alarm, Water Level Detector, Burglar Alarm, Scarecrow, Digital Lock, Doorchime, Electronic Dice, Kitchen Timer, Room Thermometer, Daily Reminder, Whistle Switch, Parking Radar, Telephone Switch, Noughts and Crosses Enigma and a Weather Vane. There is also a MW/LW Radio project in the Teach-In series.

152 pages + CD-ROM Order code ETI £8.50

### THE AMATEUR SCIENTIST 3-0 CD-ROM

The complete collection of The Amateur Scientist articles from *Scientific American* magazine. Over 1,000 classic science projects from a renowned source ever assembled for hobbyists, and professionals looking for novel solutions to research problems.

Plus over 1,000 pages of helpful science techniques that never appeared in *Scientific American*.

Exciting science projects in: Astronomy; Earth Science; Biology; Physics; Chemistry; Weather... and much more! The most complete resource ever assembled for hobbyists, and professionals looking for novel solutions to research problems.

Includes extensive Science Software Library with even more science tools.

Suitable for Mac, Windows, Linux or UNIX. 32MB RAM minimum, Netscape 4.0 or higher or Internet Explorer 4.0 or higher.

Over 1,000 projects

CD-ROM Order code ASICD-ROM £19.95

## PROJECT CONSTRUCTION

### IC 555 PROJECTS

#### E. A. Parr

Every so often a device appears that is so useful that one wonders how life went on before without it. The 555 timer is such a device. Included in this book are over 70 circuit diagrams and descriptions covering basic and general circuits, motor car and model railway circuits, alarms and noise makers as well as a section on 556, 558 and 559 timers. (Note: No construction details are given.) A reference book of invaluable use to all those who have any interest in electronics, be they professional engineers or designers, students or hobbyists.

167 pages Order code BP44 £5.49

### POWER SUPPLY PROJECTS

#### R. A. Penfold

This book offers a number of power supply designs, including simple unregulated types, and variable voltage stabilised designs, the latter being primarily intended for use as bench power supplies for the electronics workshop. The designs provided are all low voltage types for semiconductor circuits. The information in this book should also help the reader to design his own power supplies. Includes cassette PSU, Ni-Cad charger, voltage step-up circuit and a simple inverter.

91 pages Order code BP76 £5.49

### HOW TO USE OSCILLOSCOPES AND OTHER TEST EQUIPMENT

#### R. A. Penfold

This book explains the basic function of an oscilloscope, gives a detailed explanation of all the standard controls, and provides advice on buying. A separate chapter deals with using an oscilloscope for fault finding on linear and logic circuits, plenty of example waveforms help to illustrate the control functions and the effects of various fault conditions. The function and use of various other pieces of test equipment are also covered, including signal generators, logic probes, logic pulsers and crystal calibrators.

104 pages Order code BP267 £5.49

# DIRECT BOOK SERVICE

The books listed have been selected by *Everyday Practical Electronics* editorial staff as being of special interest to everyone involved in electronics and computing. They are supplied by mail order direct to your door. Full ordering details are given on the last book page.

FOR A FURTHER SELECTION OF BOOKS AND CDROMS SEE  
THE SHOP ON OUR UK WEBSITE – [www.epemag.co.uk](http://www.epemag.co.uk)

All prices include UK postage

## ELECTRONIC PROJECT BUILDING FOR BEGINNERS

### R. A. Penfold

This book is for complete beginners to electronic project building. It provides a complete introduction to the practical side of this fascinating hobby, including the following topics:

Component identification, and buying the right parts; resistor colour codes, capacitor value markings, etc; advice on buying the right tools for the job; soldering; making easy work of the hard wiring; construction methods, including stripboard, custom printed circuit boards, plain matrix boards, surface mount boards and wire-wrapping; finishing off, and adding panel labels; getting "problem" projects to work, including simple methods of fault-finding.

In fact everything you need to know in order to get started in this absorbing and creative hobby.

135 pages Order code BP392 £5.49

## TEST EQUIPMENT CONSTRUCTION

### R. A. Penfold

This book describes in detail how to construct some simple and inexpensive but extremely useful, pieces of test equipment. Stripboard layouts are provided for all designs, together with wiring diagrams where appropriate, plus notes on construction and use.

The following designs are included:-

AF Generator, Capacitance Meter, Test Bench Amplifier, AF Frequency Meter, Audio Multivoltmeter, Analogue Probe, High Resistance Voltmeter, CMOS Probe, Transistor Tester, TTL Probe. The designs are suitable for both newcomers and more experienced hobbyists.

104 pages Order code BP248 £4.49

## COMPUTING

### COMPUTING FOR THE OLDER GENERATION

#### Jim Gatenby

Especially written for the over 50s, using plain English and avoiding technical jargon. Large clear type for easy reading.

Among the many practical and useful ideas for using your PC that are covered in this book are: Choosing, setting up and understanding your computer and its main components. Writing letters, leaflets, invitations, etc., and other word processing jobs. Keeping track of your finances using a spreadsheet. Recording details of holidays and other ideas using a database. Using the Internet to find useful information, and email to keep in touch with family and friends. Making 'back-up' copies of your work and checking for viruses. How to use Windows XP to help people with impaired vision, hearing or mobility.

Provides the basic knowledge so you can gain enough confidence to join the local computer class.

308 pages Order code BP601 £8.99

### THE INTERNET FOR THE OLDER GENERATION

#### Jim Gatenby

Especially written for the over 50s. Uses only clear and easy-to-understand language. Larger type size for easy reading. Provides basic knowledge to give you confidence to join the local computer class.

This book explains how to use your PC on the Internet and covers amongst other things: Choosing and setting up your computer for the Internet. Getting connected to the Internet. Sending and receiving emails, photographs, etc., so that you can keep in touch with family and friends all over the world. Searching for and saving information on any subject. On-line shopping and home banking. Setting up your own simple web site.

228 pages Order code BP600 £8.99

## RADIO

### SETTING UP AN AMATEUR RADIO STATION

#### I. D. Poole

The aim of this book is to give guidance on the decisions which have to be made when setting up any amateur radio or short wave listening station. Often the experience which is needed is learned by one's mistakes, however, this can be expensive. To help overcome this, guidance is given on many aspects of setting up and running an efficient station. It then proceeds to the steps that need to be taken in gaining a full transmitting licence.

Topics covered include: The equipment that is needed; Setting up the shack; Which aerials to use; Methods of construction; Preparing for the licence.

86 pages Order code BP300 £4.45

### EXPERIMENTAL ANTENNA TOPICS

#### H. C. Wright

Although nearly a century has passed since Marconi's first demonstration of radio communication, there is still research and experiment to be carried out in the field of antenna design and behaviour.

The aim of the experimenter will be to make a measurement or confirm a principle, and this can be done with relatively fragile, short-life apparatus. Because of this, devices described in this book make liberal use of cardboard, cooking foil, plastic bottles, cat food tins, etc.

Although primarily a practical book with text closely supported by diagrams, some formulae which can be used by straightforward substitution and some simple graphs have also been included.

72 pages Order code BP278 £4.00

### 25 SIMPLE INDOOR AND WINDOW AERIALS

#### E. M. Noll

Many people live in flats and apartments or other types of accommodation where outdoor aerials are prohibited, or a lack of garden space etc. prevents aerials from being erected. This does not mean you have to forgo shortwave-listening, for even a 20-foot length of wire stretched out along the skirting board of a room can produce acceptable results. However, with some additional effort and experimentation one may well be able to improve performance further.

This concise book tells the story, and shows the reader how to construct and use 25 indoor and window aerials that the author has proven to be sure performers.

50 pages Order code BP136 £2.25

### AN INTRODUCTION TO RADIO WAVE PROPGATION

#### J.G. Lee

Radio wave propagation is one of the more important discoveries made in the early 20th century. Although technology lagged behind early experimenters pursued this newly discovered phenomenon eagerly for, in understanding the physics of propagation, they were discovering more about our Universe and its workings.

Radio wave propagation has its origins in the world of solar physics. The Sun's radiation provides the mechanism for the formation of the ionosphere. How the ionosphere is formed, and how it provides long-distance communication, is carefully explained. Non-ionospheric propagation, including 'moonbounce' or satellite communications, is covered as well.

This book has been written with the average electronic hobbyist in mind. Technical language and mathematics have been kept to a minimum in order to present a broad, yet clear, picture of the subject. The radio amateur, as well as the short-wave listener, will find explanations of the propagation phenomena which both experience in their pursuit of communications enjoyment.

116 pages Order code BP293 £4.45

## THEORY AND REFERENCE

### BEBOP TO THE BOOLEAN BOOGIE

Second Edition

Clive (call me Max) Maxfield

This book gives the "big picture" of digital electronics. This in-depth, highly readable, guide shows you how electronic devices work and how they're made. You'll discover how transistors operate, how printed circuit boards are fabricated, and what the innards of memory ICs look like. You'll also gain a working knowledge of Boolean Algebra and Karnaugh Maps, and understand what Reed-Muller logic is and how it's used. And there's much, MUCH more. The author's tongue-in-cheek humour makes it a delight to read, but this is a REAL technical book, extremely detailed and accurate.

Contents: Fundamental concepts; Analog versus digital; Conductors and insulators; Voltage, current, resistance, capacitance and inductance; Semiconductors; Primitive logic functions; Binary arithmetic; Boolean algebra; Karnaugh maps; State diagrams, tables and machines; Analog-to-digital and digital-to-analog; Integrated circuits (ICs); Memory ICs; Programmable ICs; Application-specific integrated circuits (ASICs); Circuit boards (PWBs and DWBs); Hybrids; Multichip modules (MCMs); Alternative and future technologies.

470 pages

Order code BEB1 £35.99

### BEBOP BYTES BACK (and the Beboputer Computer Simulator) CD-ROM

Clive (Max) Maxfield and Alvin Brown

This follow-on to *Bebop to the Boolean Boogie* is a multimedia extravaganza of information about how computers work. It picks up where "Bebop!" left off, guiding you through the fascinating world of computer design... and you'll have a few chuckles, if not belly laughs, along the way. In addition to over 200 megabytes of mega-cool multimedia, the CD-ROM contains a virtual microcomputer, simulating the motherboard and standard computer peripherals in an extremely realistic manner. In addition to a wealth of technical information, myriad nuggets of trivia, and hundreds of carefully drawn illustrations, the CD-ROM contains a set of lab experiments for the virtual microcomputer that let you recreate the experiences of early computer pioneers. If you're the slightest bit interested in the inner workings of computers, then don't dare to miss this!

Over 800 pages in Adobe Acrobat format

CD-ROM

Order code BEB2 CD-ROM £21.95



### INTERFACING PIC MICROCONTROLLERS

Martin Bates

An essential guide to PIC interfacing techniques, using circuit simulation to aid learning. Explore in detail microcontroller interfacing techniques using the popular PIC 16F877. Work through step-by-step examples interactively using circuit simulation software, supplied as assembly source code.

Interfacing PIC Microcontrollers provides a thorough introduction to interfacing techniques for students, hobbyists and engineers looking to take their knowledge of PIC application development to the next level. Each chapter ends with suggestions for further applications, based on the examples given, and numerous line drawings illustrate application of the hardware.

Step-by-step examples in assembly language are used to illustrate a comprehensive set of interfaces, and these can be run interactively on circuit simulation software, used to aid understanding without the need to build real hardware.

A companion website includes all examples in the text which can be downloaded together with a free version of Proteus's ISIS Lite.

298 pages

Order code NE48 £24.99

### GETTING THE MOST FROM YOUR MULTIMETER

R. A. Penfold

This book is primarily aimed at beginners and those of limited experience of electronics. Chapter 1 covers the basics of analogue and digital multimeters, discussing the relative merits and the limitations of the two types. In Chapter 2 various methods of component checking

are described, including tests for transistors, thyristors, resistors, capacitors and diodes. Circuit testing is covered in Chapter 3, with subjects such as voltage, current and continuity checks being discussed.

In the main little or no previous knowledge or experience is assumed. Using these simple component and circuit testing techniques the reader should be able to confidently tackle servicing of most electronic projects.

96 pages

Order code BP239 £5.49

### DIGITAL GATES AND FLIP-FLOPS

Ian R. Sinclair

This book, intended for enthusiasts, students and technicians, seeks to establish a firm foundation in digital electronics by treating the topics of gates and flip-flops thoroughly and from the beginning.

No background other than a basic knowledge of electronics is assumed, and the more theoretical topics are explained from the beginning, as also are many working practices. The book concludes with an explanation of microprocessor techniques as applied to digital logic.

200 pages

Order code PC106 £9.95

### OPERATIONAL AMPLIFIER USER'S HANDBOOK

R. A. Penfold

The first part of this book covers standard operational amplifier based "building blocks" (integrator, precision rectifier, function generator, amplifiers, etc), and considers the ways in which modern devices can be used to give superior performance in each one. The second part describes a number of practical circuits that exploit modern operational amplifiers, such as high slew-rate, ultra low noise, and low input offset devices. The projects include: Low noise tape preamplifier, low noise RIAA preamplifier, audio power amplifiers, d.c. power controllers, opto-isolator audio link, audio millivolt meter, temperature monitor, low distortion audio signal generator, simple video fader, and many more.

120 pages

Order code BP335 £5.45

### PRACTICAL ELECTRONICS HANDBOOK -

Fifth Edition. Ian Sinclair

Provides a practical and comprehensive collection of circuits, rules of thumb and design data for professional engineers, students and enthusiasts, and therefore enough background to allow the understanding and development of a range of basic circuits.

Contents: Passive components, Active discrete components, Circuits, Linear I.C.s, Energy conversion components, Digital I.C.s, Microprocessors and microprocessor systems, Transferring digital data, Digital-analogue conversions, Computer aids in electronics, Hardware components and practical work, Micro-controllers and PLCs, Digital broadcasting, Electronic security.

440 pages

Order code NE21 £24.99

## MUSIC, AUDIO AND VIDEO

### QUICK GUIDE TO DIGITAL AUDIO RECORDING

Ian Waugh

Covers:

- What computer system you need
- Sound and digital audio essentials
- What to look for in a sound card
- What effects to use
- The art of mixing
- How to burn your music to CD
- How to post your songs on the Web

All modern music recordings use digital audio technology. Now everyone with a computer can produce CD-quality recordings and this book shows you how. Written in a clear and straightforward style, it explains what digital audio recording is, how to use it, the equipment you need, what sort of software is available and how to achieve professional results.

Computer-based recording is the future of music and this book shows how you can join the revolution now.

208 pages

Order code PC121 £7.95

### QUICK GUIDE TO MP3 AND DIGITAL MUSIC

Ian Waugh

MP3 files, the latest digital music format, have taken the music industry by storm. What are they? Where do you get them? How do you use them? Why have they thrown record companies into a panic? Will they make music easier to buy? And cheaper? Is this the future of music?

All these questions and more are answered in this concise and practical book which explains everything you need to know about MP3s in a simple and easy-to-understand manner. It explains:

How to play MP3s on your computer; How to use MP3s with handheld MP3 players; Where to find MP3s on the Web; How MP3s work; How to tune into Internet radio stations; How to create your own MP3s; How to record your own CDs from MP3 files; Other digital audio music formats.

60 pages

Order code PC119 £7.45



### ELECTRONIC PROJECTS FOR VIDEO ENTHUSIASTS

R. A. Penfold

This book provides a number of practical designs for video accessories that will help you get the best results from your camcorder and VCR. All the projects use inexpensive components that are readily available, and they are easy to construct. Full construction details are provided, including stripboard layouts and wiring diagrams. Where appropriate, simple setting up procedures are described in detail; no test equipment is needed.

The projects covered in this book include: Four channel audio mixer, Four channel stereo mixer, Dynamic noise limiter (DNL), Automatic audio fader, Video faders, Video wipers, Video crispener, Mains power supply unit.

109 pages

Order code BP356 £5.45

### VIDEO PROJECTS FOR THE ELECTRONICS CONSTRUCTOR

R. A. Penfold

Written by highly respected author R. A. Penfold, this book contains a collection of electronic projects specially designed for video enthusiasts. All the projects can be simply constructed, and most are suitable for the newcomer to project construction, as they are assembled on stripboard.

There are faders, wipers and effects units which will add sparkle and originality to your video recordings, an audio mixer and noise reducer to enhance your soundtracks and a basic computer control interface. Also, there's a useful selection on basic video production techniques to get you started.

Complete with explanations of how the circuit works, shopping lists of components, advice on construction, and guidance on setting up and using the projects, this invaluable book will save you a small fortune.

Circuits include: video enhancer, improved video enhancer, video fader, horizontal wiper, improved video wiper, negative video unit, fade to grey unit, black and white keyer, vertical wiper, audio mixer, stereo headphone amplifier, dynamic noise reducer, automatic fader, pushbutton fader, computer control interface, 12 volt mains power supply.

124 pages

Order code PC115 ~~£10.95~~ £5.45

**ALL PRICES INCLUDE UK POST & PACKING**

# FAULT FINDING, CIRCUITS AND DESIGN

## PIC BASIC PROJECTS – 30 PROJECTS USING PICBASIC AND PICBASIC PRO

**BOOK + CD-ROM**

**Dogan Ibrahim**  
Covering the PICBASIC and PICBASIC PRO compilers, this thoroughly revised edition, previously entitled PICBASIC Programming and Projects, provides an easy-to-use toolkit for developing applications with PICBASIC. Numerous simple projects give clear and concrete examples of how PICBASIC can be used to develop electronics applications, while larger and more advanced projects describe program operation in detail and give useful insights into developing more involved microcontroller applications.

Packed with simple and advanced projects which show how to programme a variety of interesting electronic applications using PICBASIC. Covers the PIC16F627 and PIC16F73, and the popular PIC16F84 and PIC16F877 models. The CDROM includes program source files, HEX code, data sheets of devices, sensors and schematics of the circuits used in the book.

358 pages **Order code NE44** £21.99

## HOW ELECTRONIC THINGS WORK – AND WHAT TO DO WHEN THEY DON'T

**Robert Goodman**  
You never again have to be flummoxed, flustered or taken for a ride by a piece of electronics equipment. With this fully illustrated, simple-to-use guide, you will get a grasp on the workings of the electronic world that surrounds you – and even learn to make your own repairs.

You don't need any technical experience. This book gives you: Clear explanations of how things work in everyday language. Easy-to-follow, illustrated instructions on using test equipment to diagnose problems. Guidelines to help you decide for or against professional repair. Tips on protecting your expensive equipment from lightning and other electrical damage, lubrication and maintenance suggestions.

Covers: colour TVs, VCRs, radios, PCs, CD players, printers, telephones, monitors, camcorders, satellite dishes, and much more!

394 pages **Order code MGH3** £21.99

## PRACTICAL OSCILLATOR CIRCUITS

**A. Flind**  
Extensive coverage is given to circuits using capacitors and resistors to control frequency. Designs using CMOS, timer i.c.s and op.amps are all described in detail, with a special chapter on "waveform generator" i.c.s. Reliable "white" and "pink" noise generator circuits are also included. Various circuits using inductors and capacitors are covered, with emphasis on stable low frequency

generation. Some of these are amazingly simple, but are still very useful signal sources.

Crystal oscillators have their own chapter. Many of the circuits shown use readily available special i.c.s for simplicity and reliability, and offer several output frequencies. Finally, complete constructional details are given for an audio sinewave generator.

133 pages **Order code BP393** £5.49

## PIC IN PRACTICE (2nd Edition)

**David W. Smith**  
A graded course based around the practical use of the PIC microcontroller through project work. Principles are introduced gradually, through hands-on experience, enabling hobbyists and students to develop their understanding at their own pace. The book can be used at a variety of levels.

Contents: Introduction to the PIC microcontroller; Programming the 16F84 microcontroller; Introductory projects; Headers, porting code – which micro?; Using inputs; Keypad scanning; Program examples; The 16C54 microcontroller; Alphanumeric displays; Analogue to digital conversion; Radio transmitters and receivers; EEPROM data memory; Interrupts; The 12 series 8-pin microcontroller; The 16F87X microcontroller; The 16F62X microcontroller; Projects; Instruction set, files and registers; Appendices; Index.

308 pages **Order code NE39** £19.99

## PRACTICAL ELECTRONIC FAULT FINDING AND TROUBLESHOOTING

**Robin Pain**  
To be a real fault finder, you must be able to get a feel for what is going on in the circuit you are examining. In this book Robin Pain explains the basic techniques needed to be a fault finder.

Simple circuit examples are used to illustrate principles and concepts fundamental to the process of fault finding. This is not a book of theory, it is a book of practical tips, hints and rules of thumb, all of which will equip the reader to tackle any job. You may be an engineer or technician in search of information and guidance, a college student, a hobbyist building a project from a magazine, or simply a keen self-taught amateur who is interested in electronic fault finding but finds books on the subject too mathematical or specialised.

The fundamental principles of analogue and digital fault finding are described (although, of course, there is no such thing as a "digital fault" – all faults are by nature analogue). This book is written entirely for a fault finder using only the basic fault-finding equipment: a digital multimeter and an oscilloscope. The treatment is non-mathematical (apart from Ohm's law) and all jargon is strictly avoided.

274 pages **Order code NE22** £33.99

## A BEGINNERS GUIDE TO CMOS DIGITAL ICs

**R. A. Penfold**  
Getting started with logic circuits can be difficult, since many of the fundamental concepts of digital design tend to seem rather abstract, and remote from obviously useful applications. This book covers the basic theory of digital electronics and the use of CMOS integrated circuits, but does not lose sight of the fact that digital electronics has numerous "real world" applications.

The topics covered in this book include: the basic concepts of logic circuits; the functions of gates, inverters and other logic "building blocks"; CMOS logic i.c. characteristics, and their advantages in practical circuit design; oscillators and monostables (timers); flip/flops, binary dividers and binary counters; decade counters and display drivers.

119 pages **Order code BP333** £5.45

# AUDIO AMPS

## BUILDING VALVE AMPLIFIERS

**Morgan Jones**  
The practical guide to building, modifying, fault-finding and repairing valve amplifiers. A hands-on approach to valve electronics – classic and modern – with a minimum of theory. Planning, fault-finding, and testing are each illustrated by step-by-step examples.

A unique hands-on guide for anyone working with valve (tube in USA) audio equipment – as an electronics experimenter, audiophile or audio engineer.

Particular attention has been paid to answering questions commonly asked by newcomers to the world of the vacuum tube, whether audio enthusiasts tackling their first build, or more experienced amplifier designers seeking to learn the ropes of working with valves. The practical side of this book is reinforced by numerous clear illustrations throughout.

368 pages **Order code NE40** £23.99

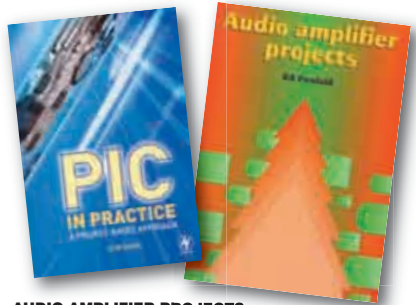

## AUDIO AMPLIFIER PROJECTS

**R. A. Penfold**  
A wide range of useful audio amplifier projects, each project features a circuit diagram, an explanation of the circuit operation and a stripboard layout diagram. All constructional details are provided along with a shopping list of components, and none of the designs requires the use of any test equipment in order to set up properly. All the projects are designed for straightforward assembly on simple circuit boards.

Circuits include: High impedance mic preamp, Low impedance mic preamp, Crystal mic preamp, Guitar and GP preamplifier, Scratch and rumble filter, RIAA preamplifier, Tape preamplifier, Audio limiter, Bass and treble tone controls, Loudness filter, Loudness control, Simple graphic equaliser, Basic audio mixer, Small (300mW) audio power amp, 6 watt audio power amp, 20/32 watt power amp and power supply, Dynamic noise limiter.

A must for audio enthusiasts with more sense than money!

116 pages **Order code PC113** £10.95 ~~£5.45~~

## VALVE AMPLIFIERS Second Edition. Morgan Jones

This book allows those with a limited knowledge of the field to understand both the theory and practice of valve audio amplifier design, such that they can analyse and modify circuits, and build or restore an amplifier. Design principles and construction techniques are provided so readers can devise and build from scratch, designs that actually work.

The second edition of this popular book builds on its main strength – exploring and illustrating theory with practical applications. Numerous new sections include: output transformer problems; heater regulators; phase splitter analysis; and component technology. In addition to the numerous amplifier and preamplifier circuits, three major new designs are included: a low-noise single-ended LP stage, and a pair of high voltage amplifiers for driving electrostatic transducers directly – one for headphones, one for loudspeakers.

288 pages **Order code NE33** £34.99

## BOOK ORDERING DETAILS

All prices include UK postage. For postage to Europe (air) and the rest of the world (surface) please add £2 per book. For the rest of the world airmail add £3 per book. CD-ROM prices include VAT and/or postage to anywhere in the world. Send a PO, cheque, international money order (£ sterling only) made payable to **Direct Book Service** or card details, Visa, Mastercard, or Maestro to: **DIRECT BOOK SERVICE, WIMBORNE PUBLISHING LIMITED, SEQUOIA HOUSE, 398a RINGWOOD ROAD, FERNDOWN, DORSET BH22 9AU.**

Books are normally sent within seven days of receipt of order, but please allow 28 days for delivery – more for overseas orders. Please check price and availability (see latest issue of *Everyday Practical Electronics*) before ordering from old lists.

For a further selection of books see the next two issues of *EPE*.  
Tel 01202 873872 Fax 01202 874562. E-mail: [db@wimbome.co.uk](mailto:db@wimbome.co.uk)  
Order from our online shop at: [www.epemag.co.uk](http://www.epemag.co.uk)

## BOOK ORDER FORM

Full name: .....

Address: .....

.....

.....

..... Post code: ..... Telephone No: .....

Signature: .....

I enclose cheque/PO payable to DIRECT BOOK SERVICE for £ .....

Please charge my card £ ..... Card expiry date.....

Card Number ..... Maestro Issue No.....

Valid From Date ..... Card Security Code ..... (the last three digits on or just below the signature strip)

Please send book order codes: .....

.....

Please continue on separate sheet of paper if necessary



# PCB SERVICE

Printed circuit boards for most recent *EPE* constructional projects are available from the *PCB Service*, see list. These are fabricated in glass fibre, and are fully drilled and roller tinned. Double-sided boards are **NOT plated through hole** and will require 'vias' and some components soldering to both sides. All prices include VAT and postage and packing. Add £1 per board for airmail outside of Europe. Remittances should be sent to **The PCB Service, Everyday Practical Electronics, Wimborne Publishing Ltd., Sequoia House, 398a Ringwood Road, Ferndown, Dorset BH22 9AU. Tel: 01202 873872; Fax 01202 874562; Email: orders@epemag.wimborne.co.uk. On-line Shop: www.epemag.com.** Cheques should be crossed and made payable to *Everyday Practical Electronics (Payment in £ sterling only)*.

**NOTE: While 95% of our boards are held in stock and are dispatched within seven days of receipt of order, please allow a maximum of 28 days for delivery – overseas readers allow extra if ordered by surface mail. Back numbers or photocopies of articles are available if required – see the Back Issues page for details. WE DO NOT SUPPLY KITS OR COMPONENTS FOR OUR PROJECTS.**

**Please check price and availability in the latest issue. A large number of older boards are listed on, and can be ordered from, our website.**

Boards can only be supplied on a payment with order basis.

PROJECT TITLE	ORDER CODE	COST
<b>SEPTEMBER '07</b>		
★ Flexitimer	631	£7.29
– Main Board	632	£7.29
– Display Board 1	633	£7.29
– Display Board 2	634	£7.29
– Display Board 3	635	£6.35
Pocket Tens Unit		
<b>OCTOBER '07</b>		
★ Simple Seismograph	636	£6.66
★ V8 Doorbell	637 } set	£11.42
– Main Board	638	
– Display Board		
★ Standby Power Saver	639	£6.34
– Transmitter	640 } set	£6.97
– Receiver	641	
– PSU		
<b>NOVEMBER '07</b>		
Vehicle Voltage Monitor	642	£6.34
★ USB Electrocardiograph	643	£7.61
★ Inductance & Q-Factor Meter	644	£7.93
Experimenter's Audio System	645 } set	£7.61
– Main Board	646	
– PSU	647	
★ Teach-In '08	647	£7.93
– Master Control Board		
<b>DECEMBER '07</b>		
iPod or MP3 Player Charger	648	£5.87
AVR ISP Socketboard	649	£7.61
★ PIC Speech Synthesiser	650	£6.03
– Playback	651	£6.66
– Record		
<b>JANUARY '08</b>		
★ Serial I/O Controller	652	£11.90
★ MIDI Drum Kit	653	£11.58
– Main Board	654	£7.61
– Display	655	£6.66
Phone/Fax Missed Call Alert	656	£7.30
★ PIC Carillon		
<b>FEBRUARY '08</b>		
MIDI Drum Kit	657	£5.39
– Optical Sensor	658 } set	£9.51
Studio Series – Stereo Preamp	659	
– Pre Amp		
– PSU	660	£5.71
Electrosmog Sniffer		
<b>MARCH '08</b>		
Fluorescent Tube Driver	661	£7.13
Studio Series – Stereo Headphone Amplifier	662	£8.24
<b>APRIL '08</b>		
★ Studio Series – Remote Control Module	663	£7.13
★ MIDI Activity Detector	664	£6.34
PIC In-Circuit Programming Add-On	665	£5.39
★ PC-Controlled Burglar Alarm	666 } set	£11.89
– Main Board	667	
– Display Board		
<b>MAY '08</b>		
★ PC-Controlled Burglar Alarm – Keypad	668	£6.18
★ Electric Mobility Buggy Monitor	669	£6.02
Mini Theremin	670	£10.15
<b>JUNE '08</b>		
★ Monopoly Money	671	£7.30
★ Universal High-Energy LED Lighting System	673	£6.82
<b>JULY '08</b>		
★ PIC MIDI Sound Wave Generator	672	£11.20

PROJECT TITLE	ORDER CODE	COST
Galactic Voice	674	£6.82
Coolmaster	675	£6.34
<b>AUGUST '08</b>		
Four-Channel A/V Selector	676	£9.51
DC Relay Switch For High Current Loads	677	£6.02
Versatile Temperature Switch	678	£6.66
★ Mains Monitor	679	£7.13
– Monitor	680	£5.71
– Interface		
<b>SEPTEMBER '08</b>		
Magnetic Cartridge Preamp	681	£7.45
★ Super Speedo Corrector	682	£6.66
Ultrasonic Eavesdropper	683	£6.82
S-Video To Composite Video Converter (double-sided)	684	£9.98
<b>OCTOBER '08</b>		
★ Intelligent Car Air-Conditioner Controller	685	£6.66
★ Cordless Power Tool Charger Controller	686	£6.18
20W Class-A Amplifier Module	687	£7.29
– Left Channel	688	£7.29
– Right Channel	689	£6.50
– PSU		
<b>NOVEMBER '08</b>		
★ 50MHz Frequency Meter – Mk. 2		
– Version 1	581	£6.66
– Version 2	582	£6.66
– Version 3	583	£6.66
Variable Turbo Boost Control	690	£6.34
Fuel Cut Defeater	691 } set	
<b>DECEMBER '08</b>		
★ Christmas Star	692	£6.97
20W Class-A Amplifier – Speaker Protector & Muting	693	£6.66
Radar Speed Gun	694 } set	£14.95
– Head	695	
– Display		
<b>JANUARY '09</b>		
20W Class-A Amplifier		
– Preamp and Remote Volume Control	696	£7.93
1000:1 UHF Prescaler (double sided)	697	£12.05

## EPE SOFTWARE

★ All software programs for *EPE* Projects marked with a star, and others previously published can be downloaded free from the Library on our website, accessible via our home page at: [www.epemag.com](http://www.epemag.com)

## PCB MASTERS

PCB masters for boards published from the March '06 issue onwards can also be downloaded from our website ([www.epemag.com](http://www.epemag.com)); go to the 'Library' section.

## EPE PRINTED CIRCUIT BOARD SERVICE

Order Code	Project	Quantity	Price
.....	.....	.....	.....
Name .....			
Address .....			
.....			
Tel. No. ....			
I enclose payment of £ ..... (cheque/PO in £ sterling only) to:			
<b>Everyday Practical Electronics</b>			
			
Card No. ....			
Valid From .....		Expiry Date .....	
Card Security No. ....		Maestro Issue No. ....	
Signature .....			

**Note:** You can also order PCBs by phone, Fax or Email or via the shop on our website on a secure server:

<http://www.epemag.com>

## **EPE** EVERYDAY PRACTICAL ELECTRONICS

Everyday Practical Electronics reaches more UK readers than any other UK monthly hobby electronics magazine, our sales figures prove it. We have been the leading monthly magazine in this market for the last twenty-three years.

### **BTEC ELECTRONICS TECHNICIAN TRAINING**

**NATIONAL ELECTRONICS VCE ADVANCED ICT HNC AND HND ELECTRONICS FOUNDATION DEGREES NVQ ENGINEERING AND IT DESIGN AND TECHNOLOGY**

**LONDON ELECTRONICS COLLEGE**  
20 PENYVERN ROAD  
EARLS COURT, LONDON SW5 9SU  
TEL: (020) 7373 8721  
[www.lec.org.uk](http://www.lec.org.uk)

[www.partridgeelectronics.co.uk](http://www.partridgeelectronics.co.uk)

For the electronic components & Hardware most companies don't bother to stock.

### **Miscellaneous**

**VALVES AND ALLIED COMPONENTS IN STOCK.** Phone for free list. Valves, books and magazines wanted. Geoff Davies (Radio), tel. 01788 574774.

**KITS, TOOLS, COMPONENTS. S.A.E. Catalogue.** SIR-KIT ELECTRONICS, 52 Severn Road, Clacton, CO15 3RB. [www.geocities.com/sirkituk](http://www.geocities.com/sirkituk)

### **Versatile Programmable PIC On Screen Display System**

Display text over any composite video signal



**PAL - NTSC compatible**

- Fully programmable
- I/O for sensor interfaces
- PIC 16F628A micro
- User definable fonts

Example code for MSF, cash register, 1-wire & GPS data display

**WWW.PIC-OSD.COM**



### **The British Amateur Electronics Club**

Archive Website. Archiving extracts for 140+ Newsletters from 1966-2002. Currently have interesting and useful selected articles from 19 Newsletters.

Also a section about built electronics projects with schematics and photos. Plus useful info., downloads and links. "NO ADVERTS!"

Website Address: <http://baec.tripod.com>

### **N.R. BARDWELL Ltd – est 1948 Electronic Component Supplies**

LED's, Semis, IC's Resistors, Caps, etc send 44p for lists. 1000's bargains at our secure site: [www.bardwells.co.uk](http://www.bardwells.co.uk) 288, Abbeydale Rd. Sheffield. S7 1FL 0845 166 2329 (local rate)

### **RSH ELECTRONICS**

UK & International Suppliers of Electronic Components & Kits  
**Seasonal Velleman & Stripboard Project Kits Including:**  
Twinkling Christmas Tree, Flashing Star, Animated Bell  
Plus a great range of hobby components for the electronics enthusiast.  
P&P £2.50 (orders over £25 free P&P) No Min Order. No VAT  
[www.rshelectronics.co.uk](http://www.rshelectronics.co.uk)

### **CPS Solar**

Solar panels, solar cells, and many more alternative energy products for battery charging etc, please visit our website for further info or call

Tel: 0870 765 2334.

[www.solarpanelsonline.co.uk](http://www.solarpanelsonline.co.uk)

### **BOWOOD ELECTRONICS LTD**

*Suppliers of Electronic Components*

Place a secure order on our website or call our sales line

All major credit cards accepted

Web: [www.bowood-electronics.co.uk](http://www.bowood-electronics.co.uk)

Unit 10, Boythorpe Business Park, Dock Walk, Chesterfield,

Derbyshire S40 2QR. Sales: 01246 200222

Send 60p stamp for catalogue



# ONLY £8.50

INCLUDING P&P FROM OUR **DIRECT BOOK SERVICE**

## **ELECTRONICS TEACH-IN** BY MIKE TOOLEY plus **FREE CD-ROM**

A broad-based introduction to electronics – find out how circuits work and what goes on inside them. Plus 15 easy-to-build projects. The 152 page A4 book comes with a free CD-ROM containing the whole *Teach-In 2006* series (originally published in *EPE*) in PDF form, interactive quizzes to test your knowledge, TINA circuit simulation software (a limited version – plus a specially written TINA Tutorial), together with simulations of the circuits in the Teach-In series, plus Flowcode (a limited version) a high level programming system for PIC microcontrollers based on flowcharts.

See our *Direct Book Service* – pages 75 to 77

# Europe's Largest Surplus Store

**20,000,000 Items on line NOW !**  
New items added daily

Established for over 25 years, UK company Display Electronics prides itself on offering a massive range of electronic and associated electro-mechanical equipment and parts to the Hobbyist, Educational and Industrial user. Many current and obsolete hard to get parts are available from our vast stocks, which include:

- ◆ 6,000,000 Semiconductors
- ◆ 5,000 Power Supplies
- ◆ 25,000 Electric Motors
- ◆ 10,000 Connectors
- ◆ 100,000 Relays & Contactors
- ◆ 2000 Rack Cabinets & Accessories
- ◆ 4000 Items of Test Equipment
- ◆ 5000 Hard Disk Drives

**We Ship Worldwide**

**Surplus Wanted**

**www.distel.co.uk**

**Display Electronics**  
29 / 35 Osborne Road  
Thornton Heath  
Surrey UK CR7 8PD

**Telephone**  
[44] 020 8653 3333  
**Fax** [44] 020 8653 8888

## Rechargeable Batteries With Solder Tags

NIMH		NICAD	
AA 2000mAh .....	£2.82	AA 650mAh .....	£1.41
C 4Ah .....	£4.70	C 2.5Ah .....	£3.60
D 9Ah .....	£7.60	D 4Ah .....	£4.95
PP3 150mAh .....	£4.95		

### Instrument case with edge connector and screw terminals

Size 112mm x 52mm x 105mm tall

This box consists of a cream base with a PCB slot, a cover plate to protect your circuit, a black lid with a 12 way edge connector and 12 screw terminals built in (8mm pitch) and 2 screws to hold the lid on. The cream bases have minor marks from dust and handling price £2.00 + VAT(=£2.35) for a sample or £44.00+VAT (=£51.70) for a box of 44.

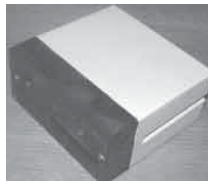

866 battery pack originally intended to be used with an orbital mobile telephone it contains 10 1.6Ah sub C batteries (42 x 22 dia. the size usually used in cordless screwdrivers etc.) the pack is new and unused and can be broken open quite easily £7.46 + VAT = **£8.77**



Please add £1.66 + VAT = £1.95 postage & packing per order

**JPG Electronics**  
Shaws Row, Old Road, Chesterfield, S40 2RB.  
Tel 01246 211202 Fax 01246 550959  
www.JPGElectronics.com  
Mastercard/Visa/Switch

Callers welcome 9.30 a.m. to 5.30 p.m. Monday to Saturday

# EP3 EVERYDAY PRACTICAL ELECTRONICS

## NEXT MONTH

### LED TACHOMETER

This tachometer is a responsive and accurate project that is a 'must have' for motoring enthusiasts. It features a bright 4-digit display plus an innovative, read-at-a-glance 32-LED circular bargraph. Definitely one for those who like to mix their electronic and automotive hobbies.

### STEREO CLASS-A AMPLIFIER – PART 5

Over the last four months we've presented some exciting high quality amplification modules. In this issue we bring all the separate parts together to build a high-performance 20W Class-A Stereo Amplifier. Never before, will your hifi have sounded so sweet!

### ADJUSTABLE 1.3V TO 22V REGULATED POWER SUPPLY

Need a regulated voltage that can be adjusted to suit your application? This Adjustable Power Supply is small, easy-to-build and can be adapted to produce a fully regulated voltage ranging from 1.3V to 22V at currents up to 1A. Now, you will never be without a non-standard supply voltage. Perfect for all experimenters and designers.

### (ALMOST) FREE VOLTMETER

Want a really cheap voltmeter? In our continuing series on something for nearly nothing we show you how to adapt a VU meter that's been scrounged from an old audio cassette deck. Good for your pocket and good for the planet!

**FEB '09 ISSUE ON SALE JAN 8**

## ADVERTISERS INDEX

AUDON ELECTRONICS .....	49
BETA-LAYOUT .....	Cover (ii)
BRUNNING SOFTWARE .....	39
COMPACT CONTROL DESIGN .....	67
CRICKLEWOOD .....	49
DISPLAY ELECTRONICS .....	80
ESR ELECTRONIC COMPONENTS .....	6, Cover (iii)
FERYSTER .....	64
JAYCAR ELECTRONICS .....	4/5
JPG ELECTRONICS .....	80
LABCENTER .....	Cover (iv)
LASER BUSINESS SYSTEMS .....	38
MAGENTA ELECTRONICS .....	49
MICROCHIP .....	21
NURVE NETWORKS LLC .....	48
PEAK ELECTRONIC DESIGN .....	73
QUASAR ELECTRONICS .....	2/3
SHERWOOD ELECTRONICS .....	49
STEWART OF READING .....	59

### ADVERTISEMENT OFFICES:

Sequoia House, 398a Ringwood Road, Ferndown, Dorset BH22 9AU  
PHONE: 01202 873872 Fax: 01202 874562  
EMAIL: epeads@wimborne.co.uk

For Editorial address and phone numbers see page 7



**Free Catalogue**  
0845 251 4363

**VELLEMAN®** is a major European distributor of high quality electronic products. They have been trading for more than 35 years and operate from Gavere, Belgium. With a network of over 17,000 dealers in more than 80 countries.

**We are now able to offer you the complete range** of their electronic kits, modules, PC based development products and test equipment. 80 page catalogue and new supplement available - email or phone for a copy. Full listing and specs of all kits & modules on our web site.

**Audio Amplifier**  
2 x 15Wrms (4 ohm) or 2 x 10Wrms (8 ohm). Overheating & short circuit protected. No need for rectifier & smoothing, only AC supply required.

- K4003** Kit £14.25
- VM113** Assembled £15.95

**Audio Amplifier**  
100Wrms @ 4ohm DC supply circuit on board with LED indication ideal for active speaker system or subwoofer, guitar amp, home theatre systems, etc. Overload & short-circuit protected.

- K8060** Kit £13.25
- VM100** Assembled with heatsink £28.75

**Audio Amplifier**  
Stereo 2 x 50Wrms or a Mono 100Wrms amplifier. Three input sensitivity settings. Overload & short-circuit protection, protection against incorrect power supply polarity. Speaker transient suppression.

- K4004** Kit £43.95

**PIC Programmer**  
Suitable for a wide range of Microchip® PIC™ microcontrollers, onboard configurable 40 pin. ZIF socket, Microcontroller selection using patch jumper, easy to use programming PICprog2006™ software included, SUBD connector set included.

- K8076** Kit £17.95

**1A Power Supply**  
Low cost universal symmetric power supply just add a suitable transformer and a heatsink, ... trimmers can be replaced by potentiometers to allow continuous adjustment of output, LED output indicators.

- K8042** Kit £9.55

**Velleman Instruments**

We also carry the Velleman range of fully assembled test equipment. This range of hand held Scopes and PC based measurement equipment, uses all the latest techniques to achieve "state of the art" equipment that would be at home in any industrial applications or in the hands of the enthusiast.

**Full specs on our web site.**

**Two channel USB PC Oscilloscope**

A digital storage oscilloscope uses the power of your PC to visualize electrical signals. Its high sensitive display resolution, down to 0.15mV, combined with a high bandwidth and a sampling frequency of up to 1GHz are giving this unit all the power you need.

- PCSU1000** USB Scope £229.95

**2MHz USB PC Function Generator**

A digital function generator which can be connected with a PC via USB. Standard signal waves like sine, triangle and rectangle are available; other sine waves can be easily created. The signal waves are created in the PC and produced by the function generator via DDS (Direct Digital Wave Synthesis).

- PCGU1000** USB Function Generator £95.00

**PIC Programmer**  
For Microchip® FLASH PIC™ microcontrollers supports 4 different 300 mil. PICs: 8p, 14p, 18p and 28p test buttons and LED indicators. Supplied with programming examples & easy connection to a PC through the serial port. Supplied with a PIC16F627 and software to compile and program your source code.

- K8048** Kit £19.95
- VM111** Assembled £26.95

**USB Interface**  
A interface board with 5 digital input & 8 digital output channels. In addition, there are two analogue inputs & two analogue outputs with 8 bit resolution. All communication routines are contained in a Dynamic Link Library (DLL). You may write custom Windows (98SE, 2000, Me, XP) applications in Delphi, Visual Basic, C++ Builder or any other 32-bit Windows application development tool that supports calls to a DLL.

- K8055** Kit £18.95
- VM110** Assembled £29.95

**USB Interface Board**  
With a total of 33 input/outputs: including analogue / digital and +1PWM output. Connection to the computer is galvanically optically isolated, so that damage to the computer is not possible thus providing a high level of secure implementation. Supplied with test software & examples.

- K8061** Kit £48.95

**High Power LED Driver**  
Power up to four 1W or two 3W high-power LEDs (not incl.) Delivers accurate constant current required by most high-power LEDs, built-in rectifier for easy connection to AC source, compact size, short-circuit protected, no heatsink required.

- K8071** Kit £4.95
- VM143/1W** for 1W LEDs £7.55
- VM143/3W** for 3W LEDs £7.95

**Remote Control by Telephone**  
Turn up to three devices on or off over the telephone. It is also possible to check the condition of a switch (open or closed). A major advantage of this circuit lies in the fact that audio signals are used to tell whether a specific output has been turned on or off. Operation is protected by a user defined code, which is simply keyed in from the telephone keypad.

- K6501** Kit £29.95

**USB DMX Interface**  
Control DMX fixtures using a PC and USB interface, test software and "DMX Light Player" software is included, a DLL is provided to write your own software. Stand-alone test function that outputs all 512 channels at a time, with adjustable levels.

- Supplied with case, lead & CDROM
- K8062** Kit £46.95
- VM116** Assembled £49.95

**..... other Velleman Instruments**

- HSP10** Handheld Scope £94.95
- HSP10SE** Handheld Scope inc case £105.00
- HSP40** Personal Scope inc case £189.95
- PC5500A** PC Digital Storage Scope £270.00
- PPS10** Personal Pocket Scope £99.00
- VP510** Panel Scope £99.00
- PCS10** 4 Channel Data Logger £29.95

**Remote Control Transmitter**  
For use with the **K8057/VM109** 2-channel RF receivers. Generates unique 32-bit code more than 1,000,000,000 unique codes code can easily be changed for safety purposes choose continuous or 'burst' transmission LED indicator.

- K8059** Kit £8.95

**Remote Control Receiver**  
Two relay contact outputs for use with **K8059** and **VM108** two channel RF codelock transmitters, toggle or pulse function selectable per output, can learn a unique 32-bit code from the transmitters, store up to 31 transmitters, LED indicators for outputs and functions.

- K8057** Kit £12.55

**Remote Control Transmitter**  
Compact 2-button IR keychain remote compatible with most Velleman IR receivers, 2 powerful IR LEDs for a range of up to 15m, 16 channels (allow use of multiple transmitters in one room), easy channel configuration, no jumpers required.

- MK162** Mini Kit £6.25

**Remote Control Receiver**  
Two channels with relay output (24VAC/DC 1A max.) ultra compact channel and reception indication through LEDs toggle / pulse selection for each channel learn mode for channel ID all settings are stored in EEPROM compatible with most Velleman Kit IR remotes.

- MK161** Mini Kit £7.95

**3-30V 3A Power Supply**  
Suitable as a power supply for all common Velleman kits using a stabilised DC voltage between 3 and 30V, 3A max. Of course this power supply unit can also be used for other purposes. By replacing the trimmer by a potentiometer, it may even be used as an adjustable power supply unit. Supplied with heat sink.

- K7203** Kit £19.95

**Sound to Light Unit**  
Low, mid and high channels. Sensitivity adjustment per channel. LED indication per channel. Attractive translucent enclosure. Microphone included. Noise suppressed according to EN55015

- K8017** Kit £27.55

**Clap On/Off Switch**  
Operate your lighting simply by clapping your hands. Good immunity against surrounding noises, '1-clap' or '2-clap'-mode selection, '2-clap'-mode features built-in safety turn-off timer (approx. 5h), output relay 'pulse' or 'loggle' selection.

- MK139** Mini Kit £7.95

**Voice Changer**  
Make your voice sound like a robot, add vibrato effect, use the 'pitch'-buttons and make your voice sound lower or higher, built-in microphone and power amplifier with volume control, just add a speaker.

- MK171** Mini Kit £7.95

**Mini PIC Application Module**  
Create your own custom PIC application without the hassle of making the hardware. 9 Free programmable I/Os. Onboard Relay, LEDs & Buzzer. PIC16F630 inc.

- VM142** Assembled £20.95

**Over 300 Kits, Mini Kits & Modules - Full Catalogue Available**



**Tel: 0191 2514363**  
**Fax: 0191 2522296**  
**sales@esr.co.uk**

**Station Road**  
**Cullercoats**  
**Tyne & Wear**  
**NE30 4PQ**

Prices Exclude Vat @17½%.  
UK Carriage £2.50 (less than 1kg).  
£5.50 greater than 1kg or >£30  
Cheques / Postal orders payable to  
ESR Electronic Components Ltd.

PLEASE ADD CARRIAGE & VAT TO ALL ORDERS

# Our new autorouter will turn this... into this...

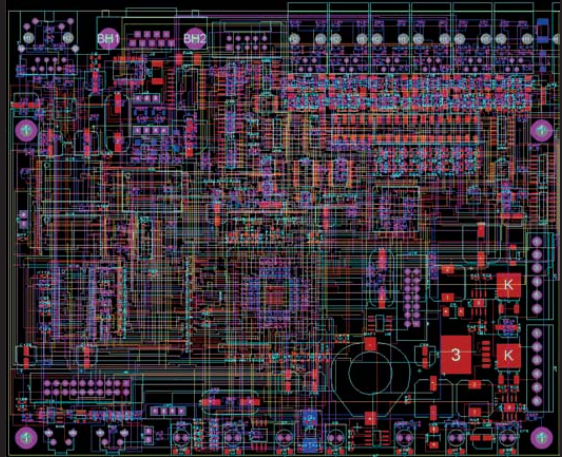
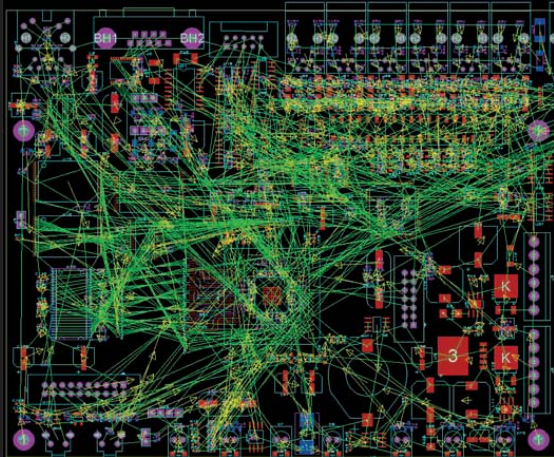

## in less than 5 minutes!

All levels of the **Proteus Design Suite** now include a world class fully integrated shape based autorouter at **no additional cost**.

The **Proteus Design Suite** also incorporates:

- Professional schematic capture
- Publication quality schematics
- Fully configurable bill of materials
- Large component libraries for both simulation and PCB layout
- Mixed mode SPICE circuit simulation
- Co-simulation of PIC, AVR, 8051 and ARM7 microcontroller firmware
- Automatic component placement and gateswap optimization
- Highly configurable design rules
- Interactive design rule checking
- Polygonal and split power planes
- RS274X, Excellon and ODB++ database export
- 3D Viewer with 3DS and DXF export

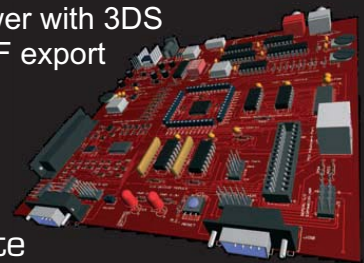

Prices start from **just £150\*** - visit our website for full details or to download a free demo.

**labcenter**  [www.labcenter.com](http://www.labcenter.com)  
**Electronics**

Labcenter Electronics Ltd. 53-55 Main Street, Grassington, North Yorks. BD23 5AA.  
Registered in England 4692454 Tel: +44 (0)1756 753440, Email: [info@labcenter.com](mailto:info@labcenter.com)



\*exc. VAT & delivery