



S E R V I C E M A N U A L

F O R

A 4 - 14 A N D A4 - 14 MK2

Audio Pro

Address	Phone	Fax	Telex
Box 65	Nat 0370-717 08	Nat 0370-762 55	40467
Hovslagaregatan 4	Int +46 370 717 08	Int +46 370 762 55	FLINTAB S
S-568 00 SKILLINGARYD			
SWEDEN			

1984-04-01

4-80149

LIST OF CONTENTS

1. TECHNICAL DESCRIPTION

1.1 Power Supply Circuits

1.2 Automatic ON/OFF

1.3 Overload protection for Midrange and Tweeter

1.4 Signal Amplifier Circuits

1.5 Bass Circuits

1.6 Ace-Bass Circuit

1.7 Midrange and Treble Circuits

1.8 Power Stage for Woofers

1.9 Power Amplifier for Midrange and Tweeter

2. FAULT FINDING

3. ADJUSTMENTS

4. SPARE PARTS

5. ENCLOSURES

5.1 Circuit diagram 2-141502 (A4-14, S/N through 12399)

5.2 Component layout 3-141504 (A4-14, S/N through 12399)

5.3 Circuit diagram 5520991-01 (A4-14 Mk2, S/N from 13400)

5.4 Component layout 4-80150 (A4-14 Mk2, S/N from 13400)

1.1 POWER SUPPLY CIRCUITS

Unregulated voltages +30V and -30V supply the Power Amplifier and also a regulator for $\pm 15V$.

-15V supply tracks +15V in order to avoid transients and oscillations when power is switched on or off. The positive supply must decay faster than the negative supply when power is disconnected, which is assured by a 2.2 kohm dummy load (R101) on the +30V capacitor.

1.2 AUTOMATIC ON/OFF

The Auto ON/OFF circuits are powered via D201, D202 and C201. The power transformers and the auto ON/OFF circuits are powered as long as the speaker A4-14 is plugged in to a live outlet. The remaining circuits are powered only in "ON" state when relay K101 is closed.

The audio signals enter via pins 3 and 5 in DIN connector J301. The other A4-14 in a stereo pair receives signals via pins 3 and 5 in DIN connector J302. The signals enter the amplifier circuits via pushbutton switches S301 - S302 which select Left or Right Channel.

The input stage of auto ON/OFF, Z202 (1,2,3) works as amplifier with gain -7 determined by feedback network R204, R205. D208 and D209 limit the amplifier signal to $\pm 7V$. The second stage, Z201 (1,2,3) works as amplifier with gain $\sim 2,000$ at 500 Hz.

The signal at pin 1 is limited to +7.0V/-7V. Z201 (5,6,7) plus transistor V201 works as a schmitt trigger with ON level approx. 7V and OFF level approx. 5V. The input, pin 5, senses a DC voltage which is obtained via diode D211 and capacitor C206.

Transistor V201 drives relay K101, which connects power to the audio circuits in A4-14. When switch S201 is in "AUTO" position, relay K101 will open about 5 minutes after the signal at the input disappeared. The time relay is determined by C206 and R210. During test you may shunt R210 by 100 kohm to obtain shorter OFF-delay.

When switch S201 is in "ON" position, the auto ON/OFF circuits are bypassed and A4-14 remains permanently ON.

A thermistor TS3-75 senses the temperature of the heatsink. When this temperature is too high, the thermistor resistance becomes so low, that relay K101 opens.

1.3 OVERLOAD PROTECTION FOR MIDRANGE AND TWEETER

Z202 (4-13) acts as an overload protection device which is actuated if there is risk for damage to the midrange driver or the tweeter.

The voltage across the voice coils are rectified in diodes D220, D219, and the rectified voltages charge capacitors C212, C211. The time constants for discharge are longer than the charging time constants. If the voltage at Z202 pins 5 or 6 exceeds a threshold value (approx. 3.4V), the mono-stable flip-flop Z202 (8-13) is triggered for 10 seconds. This causes V201 to be shut off, so relay K101 opens and A4-14 is deenergized for 10 seconds.

1.4 INPUT STAGE

When the Bass-Blend switch is off, the signals enter via R302, C302, R303.

When the Bass-Blend switch is ON, the bass frequency signals in left and right channels are added via filters C301, R301 and R304, C303, R305.

- C301, R301 is a high-pass filter with cutoff frequency 100Hz. Lower frequencies are attenuated by a factor of 2.
- R304, C303, R305 is a low-pass filter with cutoff frequency 100Hz, and attenuation 1:2 relative filter R302, C302, R303.

The signals below 100Hz are summed at Z301, pin 9. Because of the attenuation introduced in each channel, the bass level is the same as when Bass-Blend is not used.

The gain is adjusted by potentiometer R306 in the feedback circuit of operational amplifier number one. After this amplification the signals are split to bass circuits and midrange/tweeter circuits.

1.5 BASS CIRCUITS

The signal passes the bass control circuits R311, Z301 (12,13,14), which controls the signal level to the woofers. The bass control circuits affect higher frequencies (e.g. 100Hz) more than low frequencies (e.g. 30Hz).

The bass signal then passes via a low-pass link R313, C306 which forms one part of the crossover filter between bass and midrange.

The next link is a high-pass filter, which cuts frequencies below 30Hz 12dB/octave, and is part of the woofer's total transfer function.

1.6 ACE-BASS* CIRCUIT

The power amplifier for the woofer, together with Z302 (1,2,3,5,6,7) forms the ACE-BASS*, amplifier, which can be represented by the diagram below

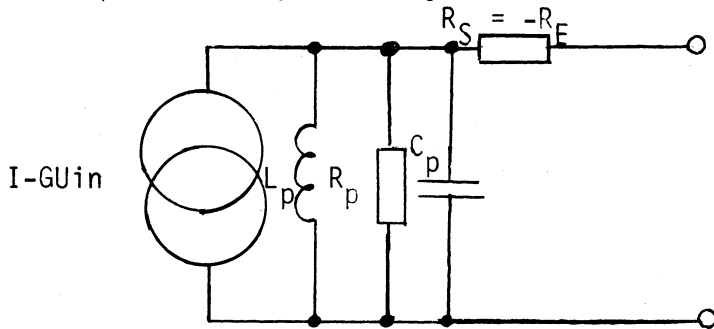

R412 and Z302 (1,2,3) sense the voice coil current in the woofers. Z302 (5,6,7) acts as a band-pass filter and sums signals from (D) and (E).

The power amplifier for the woofer is inverting and acts as adder for signals from (E) and (F).

The part of the current signal (F) which is fed back positively produces the negative output resistance R_S .

The parallel resonant circuit L_p, R_p, C_p is formed by negative feedback of the current signal via the bandpass filter.

*ACE-BASS = Amplifier Controlled Euphonic Bass.

1.7 MIDRANGE AND TREBLE CIRCUITS

From the gain control the signal is also fed to the midrange/treble amplifier. Z301 (5,6,7) acts both as high-pass filter for the crossover (C502, R501, R502) and as treble boost filter (R505, R506, C503). The high-pass link C504, R507, R508 forms the second part of the crossover filter between bass and midrange.

The power amplifier is of the inverting type, and acts as operational amplifier for the treble control R510, which is active above 5kHz.

POWER AMPLIFIER CIRCUITS

1.8 POWER STAGE FOR WOOFERS

The signal is coupled via C703 to the input of the power amplifier.

From the output, the signal is fed back negatively via R 709 and C704. When the signal amplitudes are large, negative feedback also is provided via a network of resistors and diodes. The output signal is compared to the supply voltage, and a couple of volts before clipping will occur, the signal will be rounded by the diode network so the clipping is soft.

The input stage consists of a differential stage V702 and V707 fed via a constant-current generator, V701.

The output stage is of Darlington design with transistors V710-V711 and has AC gain -1. V707 senses the temperature of the output transistors so that the bias current is constant.

V705 and V709 filter the supply voltage for the input stage, eliminating hum and other kinds of noise. (If A4-14 "pops" when switched on, one of these transistors is probably shorted).

No-signal DC-levels of voltages and currents are shown in the circuit diagram enclosed.

To avoid on-and off-transients, the bass amplifier is active only when the supply voltages exceed +17V, so that the operational amplifiers always work properly when the bass amplifier is active. When diode D712 starts conducting, the constant current generator V701 starts working, and via V712 activates even current generator V706. The amplifier is inactive when these current generators are shut off.

1.9 POWER AMPLIFIER FOR MIDRANGE AND TWEETER

The power amplifier is similar to the bass amplifier but the diode network for soft clipping is not included. The voltage-delayed on-function is also eliminated, so this power amplifier is active at low supply voltages.

The signal from the power amplifier is split in passive crossover filters L602, C616, C617 to midrange and C614, C615, L601 to the tweeter.

2 FAULT FINDING

A4-14 does not work

- 2 Set auto ON/OFF in position on
- 2.1 Check that both the green and red LED are lit.
- 2.2 Check the power fuses and fuses F601, 602, 701,702.
- 2.3 Measure supply voltages +33V \pm 2.5, -33V \pm 2.5V, +15V \pm 2V, -15V \pm 2V
- 2.4 To localize the fault, connect test instruments as follows:
 - Tone generator to J301 pins 3 and 5. Adjust till B is 42mV. Sensitivity in Max position, bass and treble pots in center position. Compare to voltage levels according to taylor in circuit diagram.
- 2.5 If fuses F601, 602, 702 blow during measurement per Section 1.4, you may disconnect the woofers and replace midrange driver and tweeter by 5-10 ohm resistors. Test again per Section 1.4 (signal levels in points E, F, G, K and J will of course be different).
- 2.6 Auto ON/OFF can also be tested with set-up per 1.4.
 - Set auto ON/OFF in AUTO.
The signal at Z201 pin 1 should be 7V p-p, and the signal Z201 pin 7 should be 15V DC.
Relay K101 should close at 15mV/500 Hz in
(R210 may be shunted by 100 kohm to reduce the off delay)

3. ADJUSTMENTS

3.1 BIAS CURRENT IN POWER AMPLIFIERS

After replacing any output transistor in any of the power amplifiers, the bias current must be readjusted. Setting of bias current should be done while heatsinks are at room temperature, that is immediately after A4-14 is turned on.

Set potentiometer R722 or R617 till DC voltage between emitters of V710, V711 reads 10mV or voltage between V 610, V 611 reads of 20mV, which corresponds to 23mA bias current.

NOTE: When output transistors are replaced, heat sink compound must be applied to both sides of the insulation washers and to the temperature compensating transistors. Check that insulation is adequate and that the power transistors are mounted flat against the heatsink. The heatsink must be screwed on to the PC card before the transistors are soldered in.

3.2 NEGATIVE OUTPUT RESISTANCE

After replacing a woofer, or any of the current sensing resistors R408-R412, the negative output resistance must be re-adjusted.

The woofers must be properly mounted in the cabinet, their voice coils must be connected, and the bass adjustment potentiometer R311 must be in center position. Voice coils must be cold (at room temperature).

Apply an input signal of 60Hz \pm 1Hz and adjust signal generator till test point (G) reads 0dB (=0.775V). Change frequency to 180Hz \pm 3Hz without changing the signal level of the signal generator, and set potentiometer R410 till voltage at test point (G) is -5.5dB (5.5dB below 60Hz).

Go back and forth between 60Hz and 180Hz and readjust if required until the difference is stable at 7.3dB.

4. SPARE PARTS

Spare parts can be obtained from Audio Pro Sweden, or from Distributors and Service Centers.

When ordering spare parts, please refer to serial number of speaker, and component number per circuit diagram 2-141504 resp. 5520991-01

This document must not be copied, either completely or in part, without our permission. Any infringement will lead to legal proceedings.

Material ordered with reference to this specification shall in every respect meet the requirements and data stated herein.

Den här scheman, kretsplan, tekniska beskrivningar, översättningar, etc. är skyddade av patentlag.

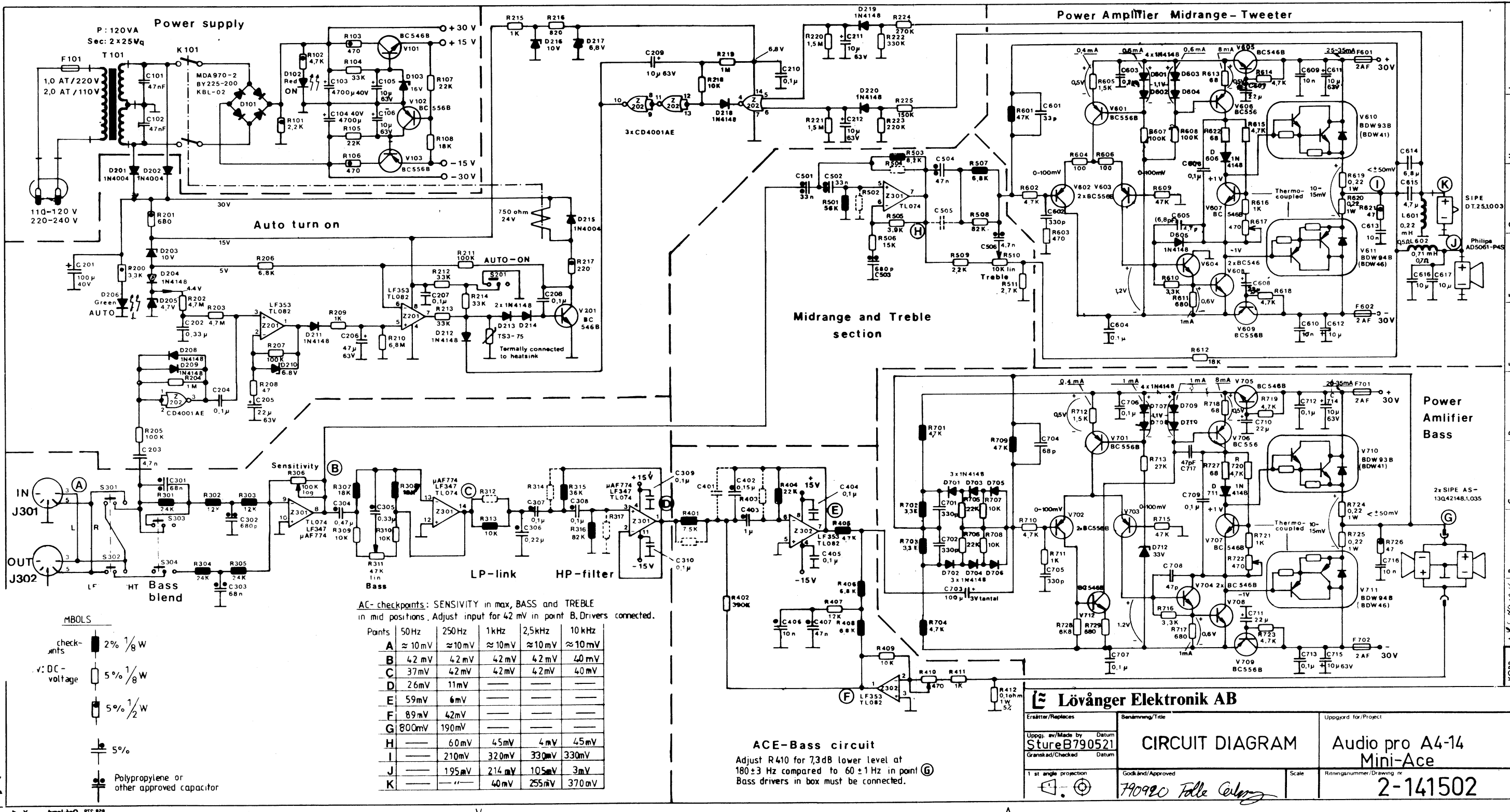

AC-checkpoints: SENSIVITY in max, BASS and TREBLE in mid positions. Adjust input for 42 mV in point B. Drivers connected.

Points	50 Hz	250 Hz	1 kHz	2,5 kHz	10 kHz
A	≈ 10 mV	≈ 10 mV	≈ 10 mV	≈ 10 mV	≈ 10 mV
B	42 mV	42 mV	42 mV	42 mV	40 mV
C	37 mV	42 mV	42 mV	42 mV	40 mV
D	26 mV	11 mV	—	—	—
E	59 mV	6 mV	—	—	—
F	89 mV	42 mV	—	—	—
G	800 mV	190 mV	—	—	—
H	—	60 mV	45 mV	4 mV	45 mV
I	—	210 mV	320 mV	330 mV	330 mV
J	—	195 mV	214 mV	105 mV	3 mV
K	—	—	40 mV	255 mV	370 mV

ACE-Bass circuit
Adjust R410 for 7,3dB lower level at 180±3 Hz compared to 60±1 Hz in point G. Bass drivers in box must be connected.

- MBOLS**
- check-points 2% 1/8 W
 - DC-voltage 5% 1/8 W
 - 5% 1/2 W
 - 5%
 - Polypropylene or other approved capacitor

Lövånger Elektronik AB

Ersätter/Replaces	Benämning/Titel	Uppgjord för/Project
Uppgjord/By Made by Sture B790521	CIRCUIT DIAGRAM	Audio pro A4-14 Mini-Ace
Granskad/Checked	Godkänd/Approved	Scale
1st angle projection	790980 Folle Colony	Ritningsnummer/Drawing nr 2-141502

This document must not be copied, either completely or in part, without our permission. Any infringement will lead to legal proceedings.

Material ordered with reference to this specification shall in every respect meet the requirements and data stated herein.

Denna handling får ej utan vårt medgivande delges annan, kopieras eller eljest obehörigen användas. Överträdelse härav beivras med stöd av gällande lag.

*Monteras upplyftade från kortet (10st motstånd)
 *Install at distance from card (10 resistors)
 R410 R617 R722 låses med lack efter trimning
 lock with varnish after adjustment

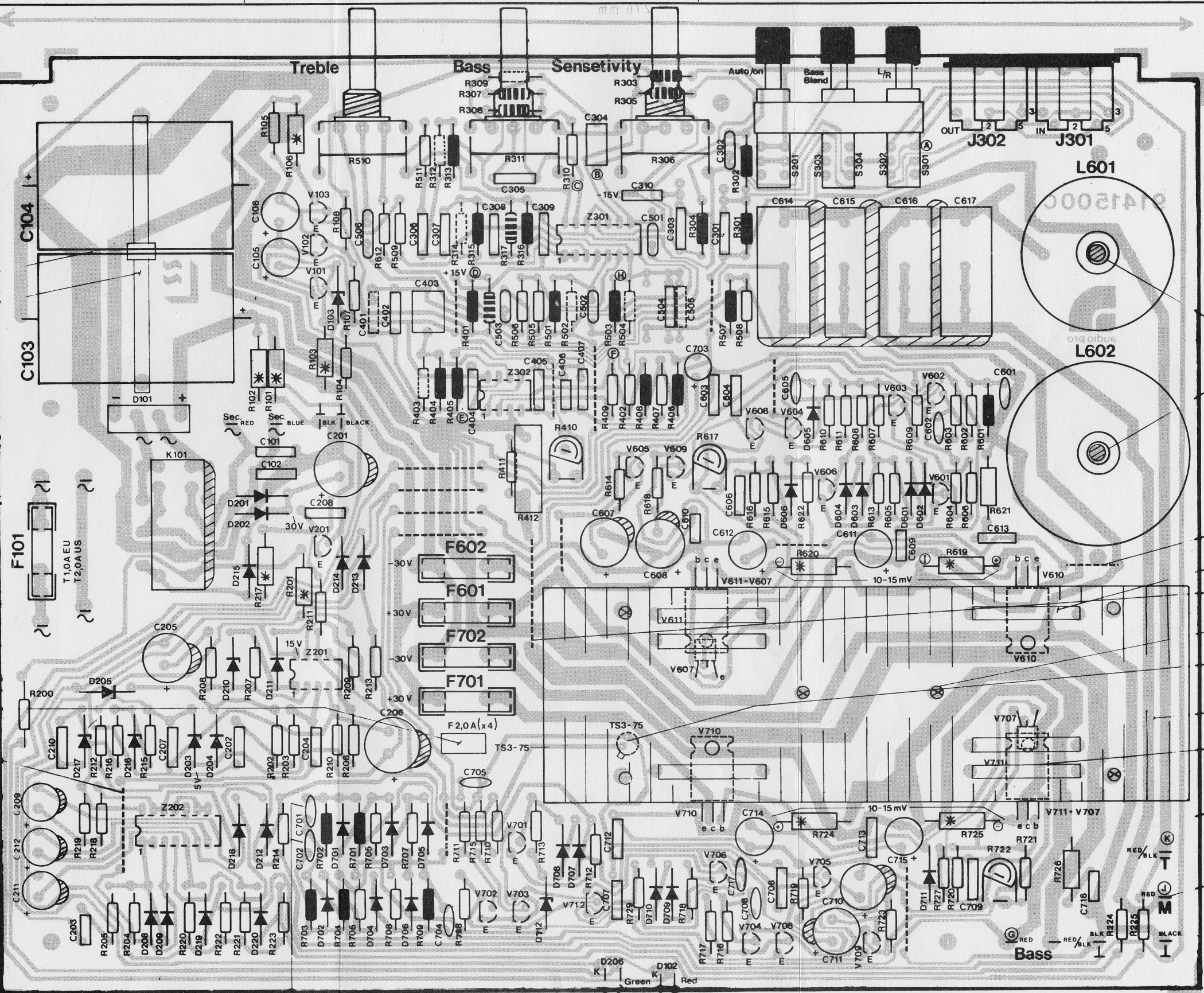

C701 C702 monteras upplyftade och bockade

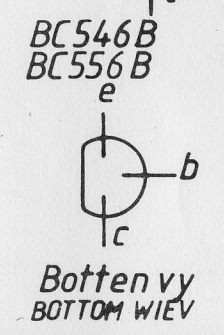
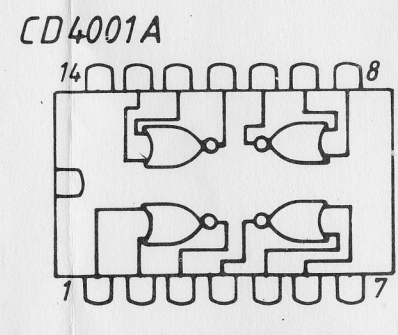
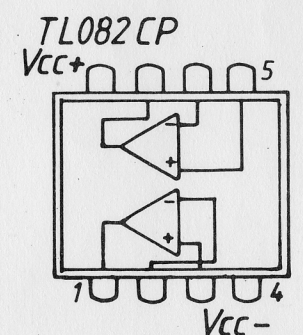
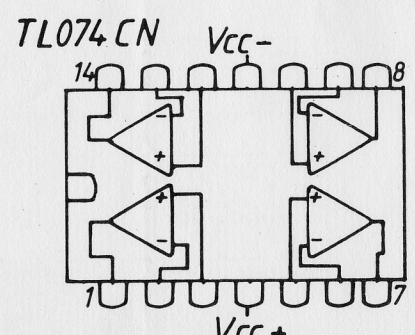

Botten vy
 BOTTOM VIEW

AMP. INVER.
 GAIN 3x, 8dB

Enclosure 5.2

		Uppgjord för/Project audio pro A4-14	
Ersätter/Replaces Uppgj. av/Made by MG 790827 Granskad/Checked	Benämning/Title KOMPONENTPLACERING COMPONENT LAYOUT MINI-ACE	Godkänd/Approved 790828 Folke Carlsson	Ritningsnummer/Drawing nr 3-141504
1 st angle projection	Scale 1:1	16 17 5 x 8 12 10 13 3 7 9 15 1 2 Limmas med 3140	

KORR A B C D E F G H I

POWER SUPPLY

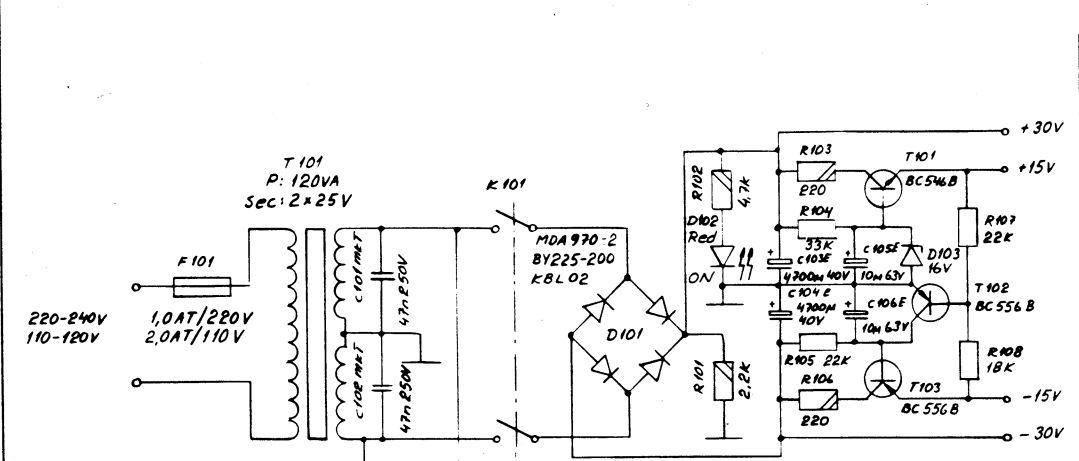

POWER AMPLIFIER MIDRANGE - TWEETER

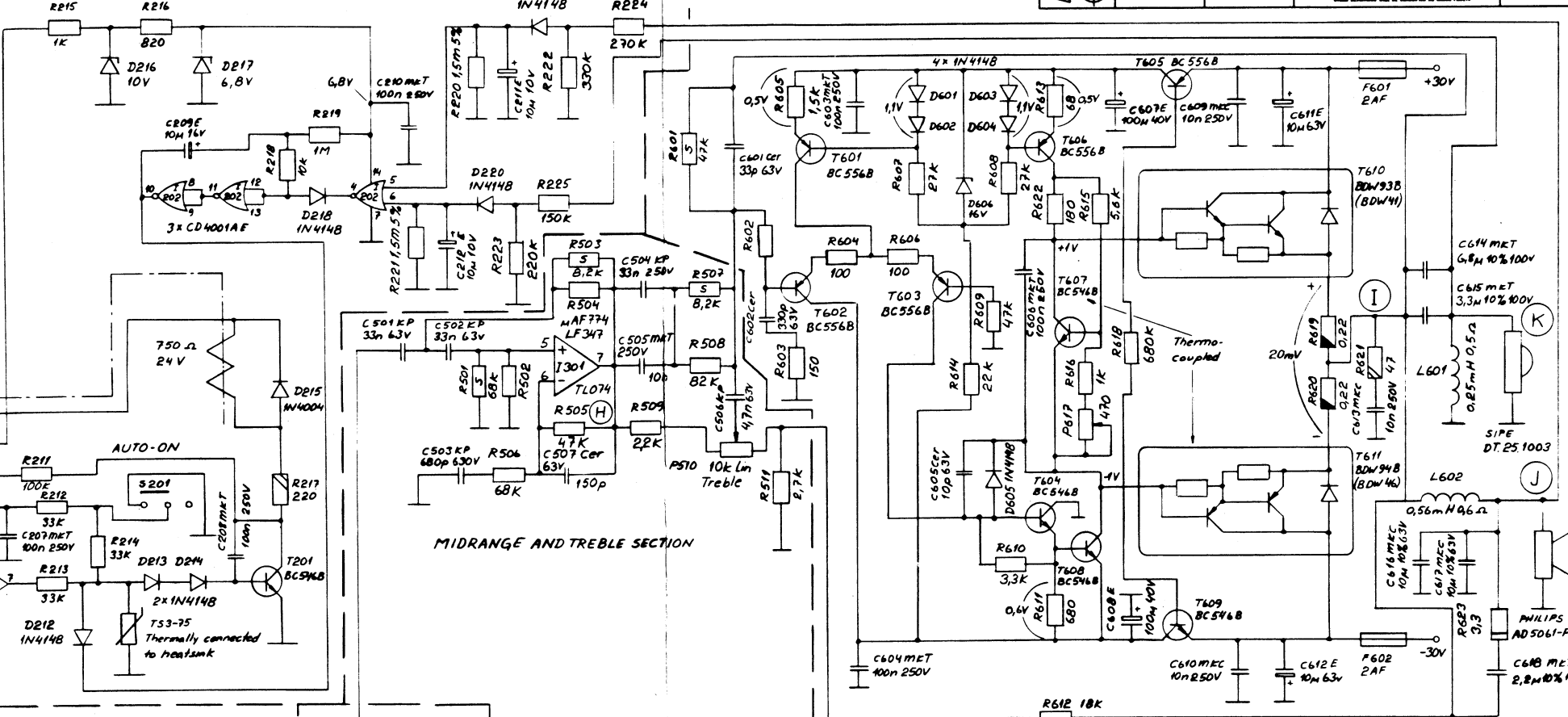

AUTO TURN ON

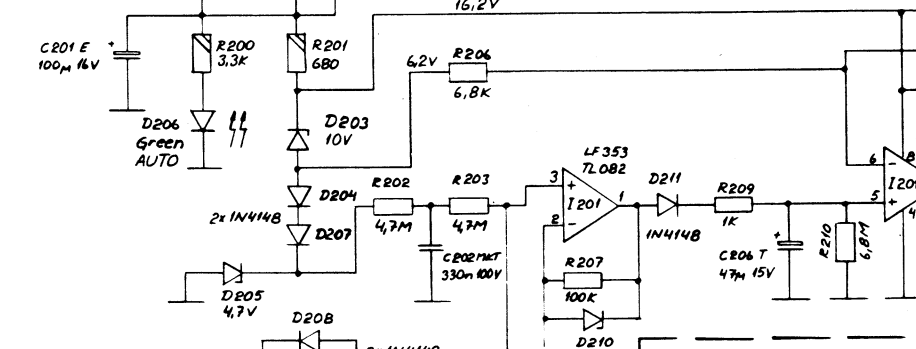

MIDRANGE AND TREBLE SECTION

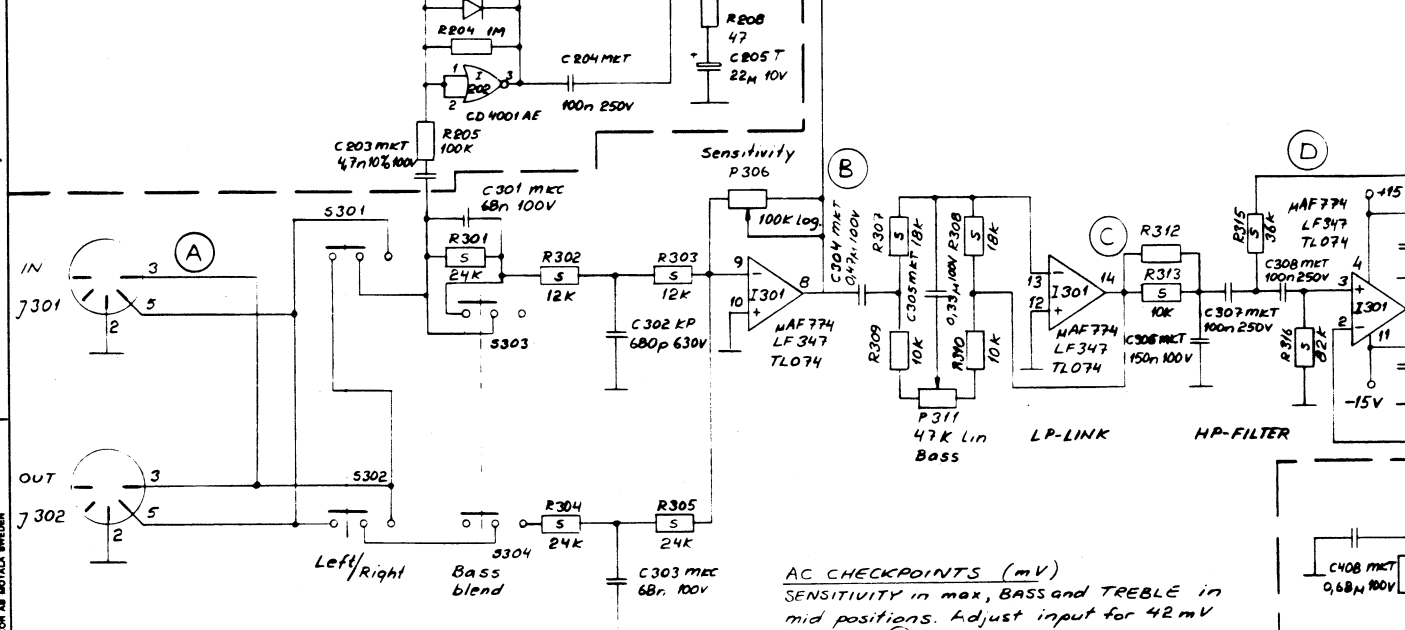
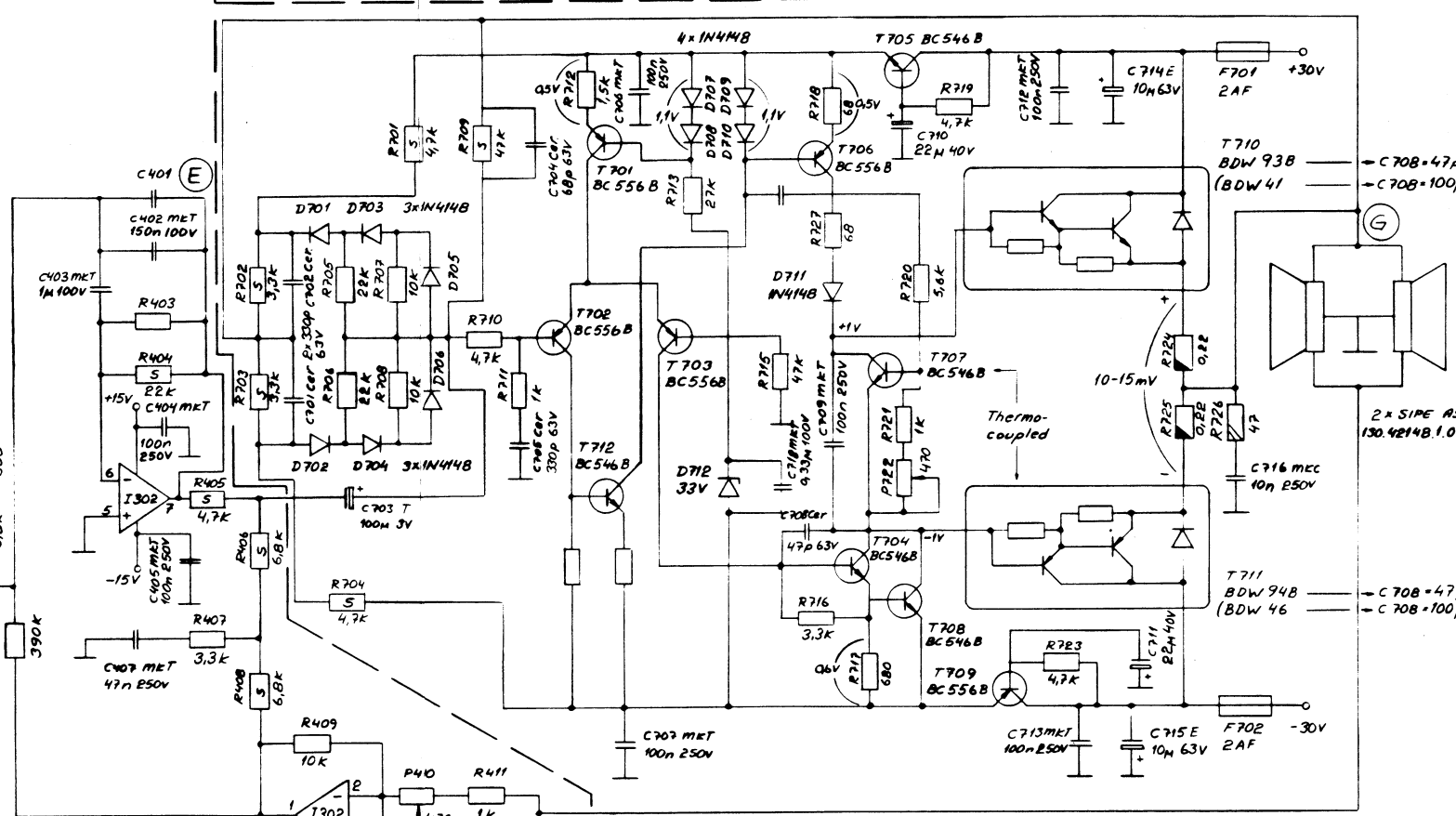

AC CHECKPOINTS (mV)
SENSITIVITY in max, BASS and TREBLE in mid positions. Adjust input for 42 mV in point (B). Drivers connected.

Point	50Hz	125Hz	1kHz	2.5kHz	10kHz
A	10mV	10mV	10mV	10mV	10mV
B	42	42	42	42	40
C	36	42	42	42	42
D	28	16			
E	63	8			
F	130	52			
G	930	240			
H	71	53	60	65	
I	210	320	400	460	
J	200	250	117	35	
K			29	240	530

- 0.5W 5%
- 0.3W 2% (1%) 2W 5%
- 0.3W 5% 1W 5%
- ⊖ MET: Met. polyester 5%
- ⊖ KP: Polypropylene 5%
- ⊖ MEC: Polycarbonate 5%
- ⊖ E: Electrolytic
- ⊖ T: Tantalum
- ⊖ Cer: Ceramic 2%

ACE-Bass circuit

Adjust R410 for 5.5 dB lower level at 180±3Hz compared to 60±1Hz in point (G). Bass drivers in box must be connected.

POWER AMPLIFIER BASS

Enclosure 5.3

This drawing is not property and must not be reproduced without the permission of Lusor Electronics. It is intended for use in the assembly of the product. Lusor Electronics is not responsible for any damage or loss of data caused by the use of this drawing.

Lusor Electronics AB

REV	DATE	BY	DESCRIPTION
1	84-04-26	KD	Table added
2			
3			

SCALE: 1:1

MATERIAL: 2205016

REVISION: A4-14 Mk2

DATE: 84-04-26

BY: KD

APPROVED: [Signature]

PROJECT: 5520991-01

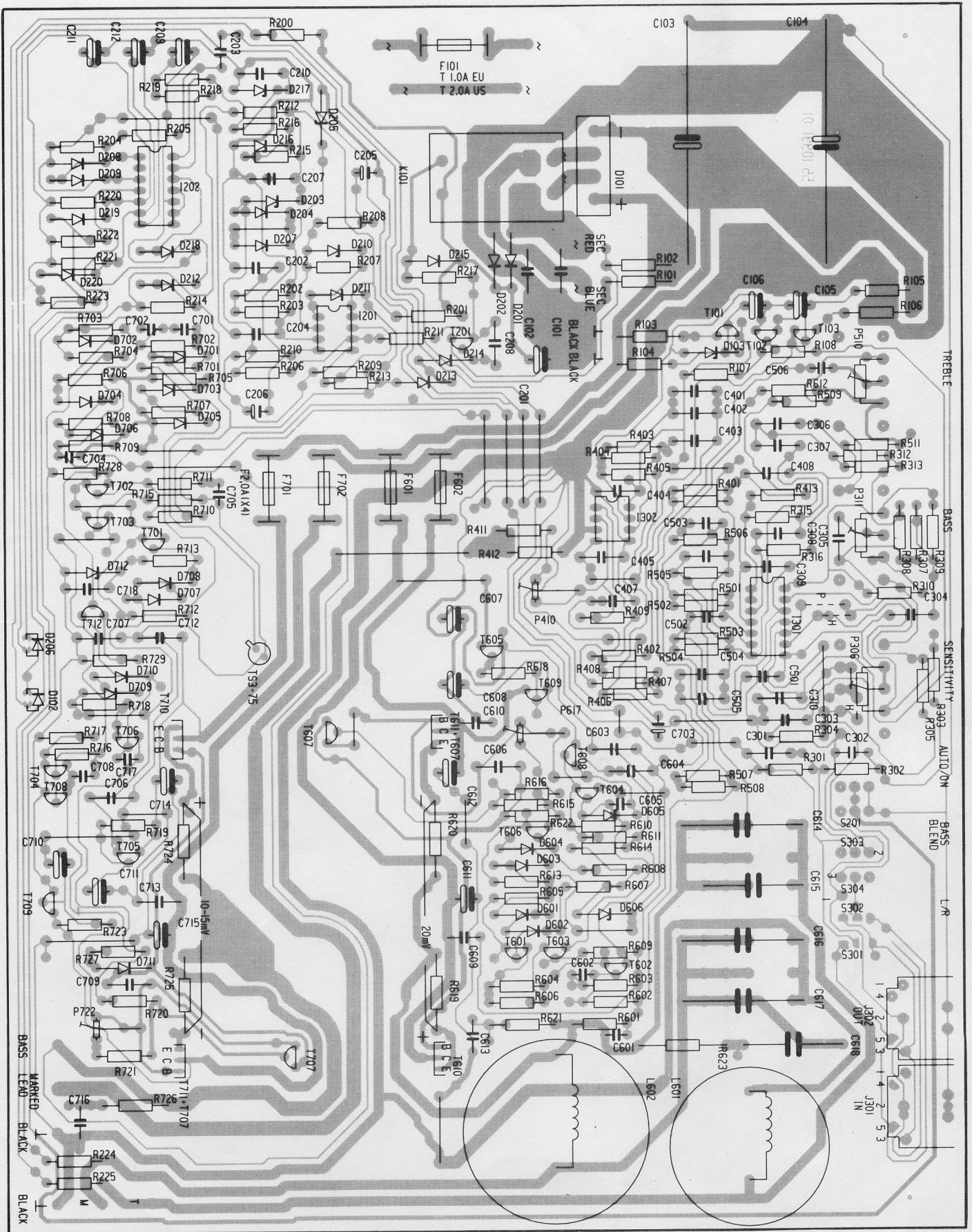

This document must not be copied without our written permission, and the contents thereof must not be imparted to a third party nor be used for any unauthorized purpose. Contravention will be prosecuted.

Antal/Qty		Pos./Item	Benämning/Description		Material/Detalj	
C	B	A	Ritad/Drawn	Kontr./Checked	Dat./Date	Skala/Scale
			KN		840507	-
A4-14 Mk2						
COMPONENT LAYOUT						

Enclosure 5.4

audio pro
SWEDEN

Ritn.-nr/Drg No. 4-80150
Rev. No.