

All 33uF caps 16v all others 50v unless marked otherwise. Resistors marked with # are 1% film type. The "Drive" LED indicates how hard the tube is being driven. The "Blend" control allows for a mixing of SS and tube coloration. Symmetry controls the relative amounts of even and odd harmonics, CCW the Tube Mic Pre may sound punchier, while CW it may sound warmer. The 12VAC needed for pin 5 of the 12AX7 can be obtained from point G while pin 4 should be connected to point A.

### USING STEREO PHONE JACKS FOR INPUT

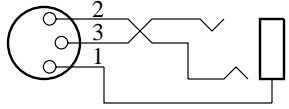

This mod converts the XLR jacks to 1/4" balanced stereo jacks. However, when a mono plug is used with this new jack the inverting input of the differential amp is grounded, this single-ends the balanced input so standard phone plugs on dynamic mics can be plugged in directly. Additionally the polarity switch still works, even for unbalanced inputs. If phantom power is not turned off while using a single ended input the performance of the TMP will not be up to par but it won't damage the TMP either.

### USING THE TMP WITH LINE LEVEL SIGNALS

There are two options for line level signals. First if you know that you'll be using line level signals all the time with the TMP then you can change the two 33k 1% resistors to 1k 1% types and you're done. Alternatively if you want the option of line level or low level signals then you can sacrifice the polarity switch and rewire it here as shown. Notice that the 47k resistors are again of the 1% variety.

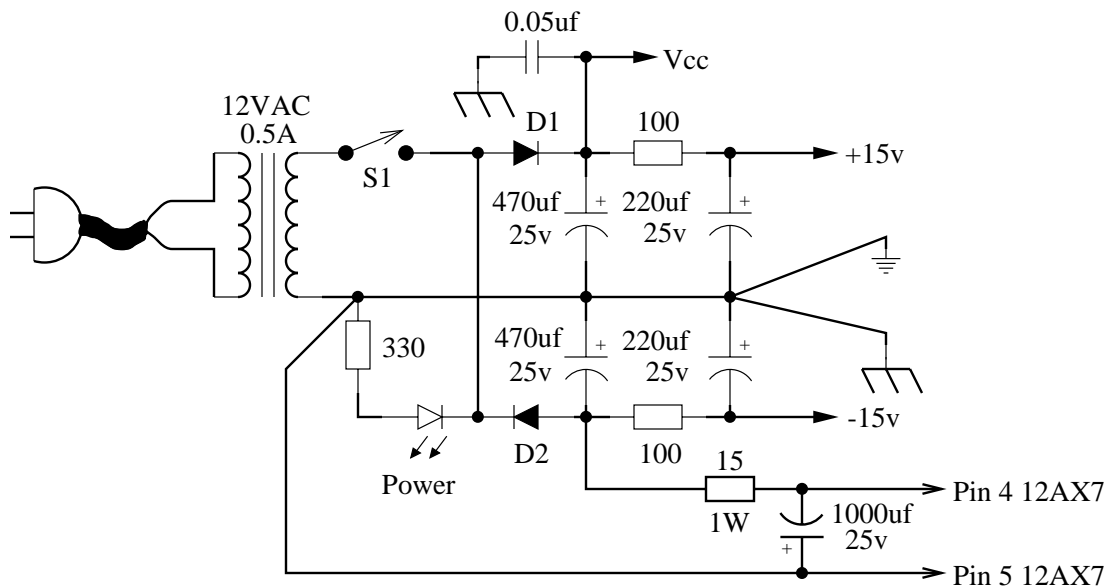
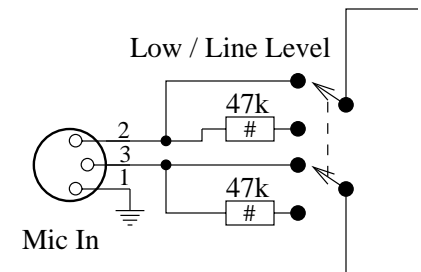

### USING DC TO POWER THE HEATER FILAMENTS

This mod can make the TMP quieter. Instead of using the 12VAC to power the heater filaments rectified and filtered DC can be used. This is accomplished as shown. The new resistor added is a 15 ohm 1W type, the new cap is a 1000uf 25v as shown. It is critical that pin 5 of the 12AX7 connects to the ground point shown.